

Smart Positioners to Predict Health of ESD Valves

As presented at:
59th Annual Instrumentation Symposium for the Process Industries
Texas A&M University College Station, Texas
January 20-22, 2004
By:

Riyaz Ali
FIELDVUE Business
Development Manager
Fisher Controls International LLC
Marshalltown, IA 50158

Dr. William Goble
Principal Partner
exida
Sellersville, PA 18960

INTRODUCTION

The operation of many industrial processes, especially those in the chemical or oil & gas industries, involves inherent risk. Safety Instrumented Systems (SIS) are specifically designed to protect personnel, equipment, and the environment by reducing the likelihood or the impact severity of an identified hazard. These SIS involve final control elements such as emergency shutdown valves, emergency venting valves, emergency isolation valves, etc. These valves are not continually moving like a typical control valve, but are normally expected to remain static in one position and then reliably operate only when an emergency situation arises. Valves which remain in one position for long periods of time are subject to becoming stuck in that position and may not operate when needed. This could result in a dangerous condition leading to an explosion, fire, and/or a leak of lethal chemicals and gases to the environment. To ensure the needed integrity of these valves, they need to be tested at a periodic schedule determined by a probabilistic failure calculation.

These periodic tests can be done manually. However the effectiveness of such testing may be questioned. The traditional method of manually testing these safety valves involves a momentary movement generated by a technician. The technician observes movement and declares the test successful. This method does not provide any internal valve diagnostics. This method will not detect if the valve friction is increasing, process build up is occurring on bearing / shaft area or actuation pressure is decaying etc.

The Concern

Testing to verify functional safety of a shutdown valve is a challenging problem, especially if testing must be done on-line. If a valve needs to be moved to 100% full travel, this can only be done on-line when a bypass valve is open. Alternatively the testing is done off-line typically during a major process shutdown / turnaround. Given

the trend toward a longer time period between major process turnarounds, valve testing becomes a bigger problem.

If a safety instrumented function is designed such that the valve can only be tested off-line and the time interval between tests is long, then safety integrity requirements drive designs toward multiple valves. This can be very expensive.

An alternative is to test the valve on-line, when process is running. This can be done manually if there is a bypass valve around safety shut down valve. The test procedure for the manual can be a bit complicated and every time the test is done, there is a chance that the bypass valve may be inadvertently left in the bypass position creating a dangerous situation. If the bypass valve is not in the bypass position during the test, a false trip will occur causing loss of production.

Recently smart valve positioners have been applied to the on-line testing problem. These devices can automatically perform a partial stroke test, measure relevant variables around the valve and diagnose more potentially dangerous failures than manual test methods. In addition these devices will respond to a process demand even during the middle of a test. Partial valve stroke testing can be done without using a bypass valve. Smart valve positioners provide an effective technology to improve safety and plant availability.

A Safety Instrumented Function

The equipment used to implement a safety function is often called a safety instrumented function. This equipment set is designed to protect against a specific industrial hazard. An example might be a high pressure protection function for a process vessel as shown in Figure 1.

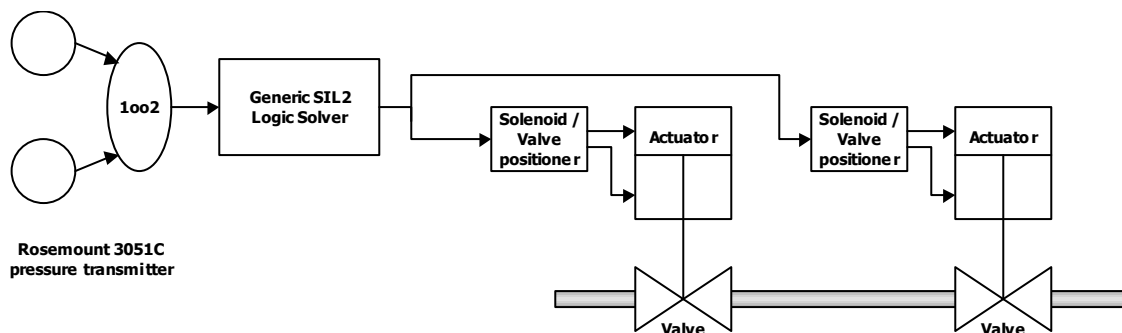

Figure 1 Conceptual design for SIL2 safety instrumented function

The conceptual design consists of the following equipment. Two Rosemount 3051C pressure transmitters in a 1oo2 voting arrangement are used as the pressure sensor devices. A SIL2 Certified PLC is used as the logic solver. Finally two 3-way solenoids each operating an actuator with ball valve in a 1-out-of-2 voting arrangement are used as the final element devices.

During the SIL verification a proof test interval of 12 months and a Mean Time To Repair of 8 hours are used. The results of the SIL verification, shown in figure 2, indicate that the conceptual design of the SIL2 safety instrumented function meets the SIL2 requirements based on the average Probability of Failure on Demand value as the PFDavg value for the entire safety instrumented function is 3.86E-03. Furthermore the conceptual design of the SIL2 SIF also meets the SIL2 requirements based on the architectural constraints concept.

<u>Sensor Part Information</u>	
Sensor Group(s)	Edit
(1) Pressure group	Details
PFDavg Sensor Part:	3.25E-05
MTTFS Sensor Part (years):	123.23
Maximum SIL allowed (Architectural Constraints):	2
<u>Logic Solver Part Information</u>	
Logic Solver	Edit
(1) Safety PLC	Details
PFDavg Logic Solver Part	2.00E-03
MTTFS Logic Solver Part (years)	3.27
Maximum SIL allowed (Architectural Constraints):	2
<u>Final Element Part Information</u>	
Final Element Group(s)	Edit
(1) Shutoff valves	Details
PFDavg Final Element Part:	1.84E-03
MTTFS Final Element Part (years):	12.39
Maximum SIL allowed (Architectural Constraints):	2
<u>SIF Performance Metrics</u>	
Safety Instrumented Function	Preview
Average Probability of Failure on Demand (PFDavg)	3.86E-03
Safety Integrity Level	2
Safety Integrity Level (Architectural Constraints)	2
Risk Reduction Factor	259
MTTFS (years)	2.53

Figure 2 Results of exida SILver tool SIL calculations

While the design meets the SIL2 requirement, two valves are expensive and the ongoing periodic test cost is also expensive. Therefore a new conceptual design is created for the SIL2 safety instrumented function using a single DVC6000 ESD device to operate a single actuator with ball valve combination instead of the two 3-way solenoids each operating an actuator with ball valve. This new SIL2 safety instrumented function conceptual design is illustrated in figure 3.

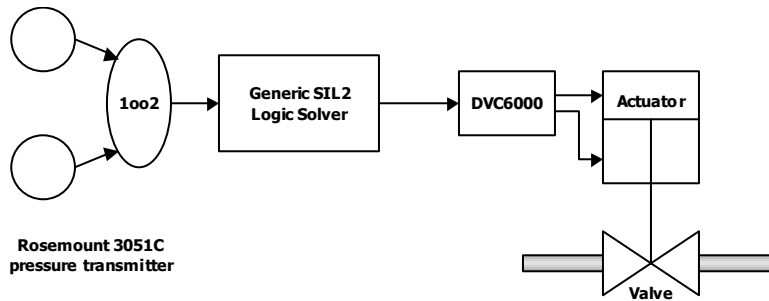

Figure 3 New conceptual design for SIF

The results of the SIL verification, shown in figure 4 for the final element part and the total safety instrumented function, indicate that this new conceptual design of the SIL2 safety instrumented function also meets the SIL2 requirements based on the average Probability of Failure on Demand value as well as the SIL2 requirements based on the architectural constraints concept.

Final Element Part Information	
Final Element Group(s)	Edit
(1) Shutoff valves	Details
PFDavg Final Element Part:	6.46E-03
MTTFS Final Element Part (years):	52.73
Maximum SIL allowed (Architectural Constraints):	2
SIF Performance Metrics	
Safety Instrumented Function	Preview
Average Probability of Failure on Demand (PFDavg)	8.48E-03
Safety Integrity Level	2
Safety Integrity Level (Architectural Constraints)	2
Risk Reduction Factor	118
MTTFS (years)	3

Figure 4 SIF verification results for new SIF design

Considering that the new conceptual design of the SIL2 SIF only uses a single DVC6000 ESD device that operates a single actuator with ball valve combination it can be concluded that the new conceptual design meets the SIL2 requirements at a significantly lower cost. Besides that the new design also has a higher Mean Time To Fail Spurious, meaning a reduced risk for nuisance trips of the safety instrumented function.

Why does the partial valve stroke testing become so effective?

Partial valve stroke testing detects a significant percentage of potentially dangerous failures in the actuator, the valve and within itself. When these failures are detected and repaired, the safety integrity of a safety instrumented function is considerably improved. Consider the results of a detailed FMECA on a pneumatic spring return Scotch Yoke Actuator as presented in figure 5.

Total failure rate	1.38E-06		
Safe failure rate	9.19E-07	% safe failure	66.64%
Dangerous failure rate	4.60E-07		
NoEffect failure rate	4.26E-07		
PVST - dangerous detected	4.26E-07	SFF no PVST	74.51%
PVST - dangerous undetected	3.40E-08	SFF with PVS	98.12%

Figure 5 FMECA results for pneumatic actuator

Partial valve stroke testing detects 92% of the potentially dangerous failures in the actuator. A similar analysis for valves indicate that the number is between 60% and 90% depending on the need for tight shut off in the valve and other operating conditions.

When this much of the total dangerous failure rate can be detected by an automatic diagnostic, safety integrity is improved. At the same time, many incipient safe failures are detected allowing false trips to be prevented.

Smart positioners are digital valve controllers that are communicating, microprocessor-based current-to-pneumatic instruments with internal logic capability. In addition to the traditional function of converting a current signal to a pressure signal to operate the valve, these smart positioners use HART® communications protocol to give easy access to diagnostic information.

High levels of diagnostic coverage are achieved because the valve status and its response to mechanical movement can be monitored during the test. Valve performance trends are monitored and automatically analyzed after each partial-stroke test so that potentially failing valves can be identified long before they become unavailable. A cycle counter and travel accumulator will show the extent of valve movement.

The results of a signature test (See figure 6) can be used to determine packing problems (through friction data), leakage in the pressurized pneumatic path to the actuator, valve sticking, actuator spring rate, and bench set. The smart positioner can save the results of this data for printout or later use. Overlaying the results of the current signature test with those of tests run in the past can indicate if valve response has degraded over time. This increases valve availability and ensures that the valve

responds upon demand. It also reduces the amount of scheduled maintenance on the valve, because the tests can be used to predict when the valve needs maintenance.

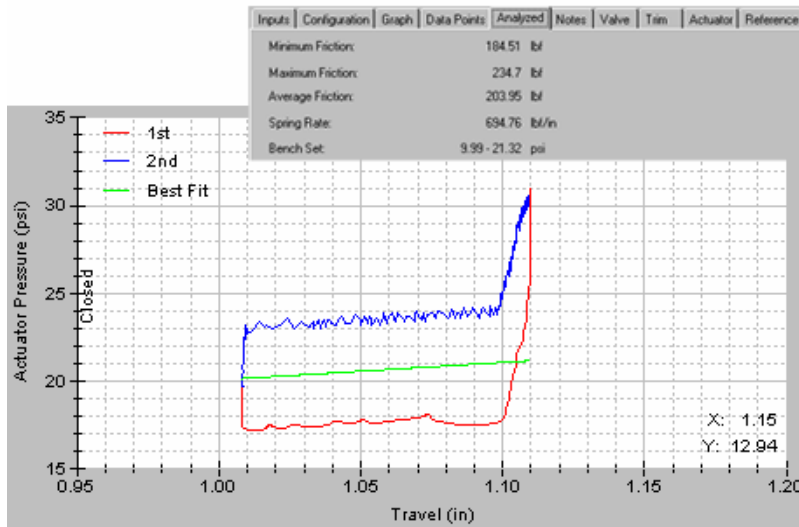

Figure 6 Valve signature used for diagnostics

Some smart positioners have the capability to alert the operator if a valve is stuck. As the positioner begins the partial stroke, it continually checks the valve travel to see if it is responding properly. If it is not, the positioner will abort the test and alert the operator that the valve is stuck. This will prevent the valve from slamming shut if the valve does eventually break loose.

CONCLUSION

Smart positioners are a great aid to predictive maintenance by providing a Valve Degradation Analysis, which is important for critical valves in safety related systems. This also reduces the amount of scheduled maintenance. While performing the partial-stroke test, if for any reason the valve is stuck, some smart positioners will not completely exhaust the actuator pressure. This assures that, should the valve become unstuck, it will not slam shut. These smart positioners will then abort the test and send an alert signal to the operator warning that the valve is stuck.

The smart positioner provides a time and date stamp on all tests and reports, which is very important for complying with the requirements of statutory authorities. It also provides the capability for comparing and interpreting diagnostic data.

Smart positioners allow partial-stroke testing while the process is running with no threat of missing an emergency demand. This type of test applies a small ramp signal to the valve that is too small to disrupt the process, but is large enough to confirm that the valve is working properly.

While obvious diagnostics, performance and safety benefits can be gained through partial-stroke testing, many additional benefits can be obtained by using a smart

positioner. Lower base equipment cost is achieved with considerable reduction in testing time and a reduced manpower requirement through the elimination of expensive pneumatic test panels and skilled personnel presently required for testing. In addition, remote testing capability requires fewer maintenance trips to the field, as well as the establishment of an automated test routine that can produce great time savings.