

# Tight shutoff in boiler feedwater control valves

By Mr J. Wilson, Fisher Controls International

Boiler feedwater valves face the most severe startup conditions to be found anywhere within a power plant, a situation that can become highly significant in terms of costly trim damage, expensive leakage and difficult control. Because feedwater valves are critical to a plant's operation and performance, it is essential that they be specified properly. This relates both to the valves' ability to control and to provide tight shutoff, factors that often are overlooked in the valve selection process.

## Feedwater recirculation valve

The boiler feedwater recirculation valve must withstand a high inlet pressure ranging from 2500 to 4500 psig and a minimal downstream pressure. This significant pressure drop can lead to cavitation (the formation and subsequent collapse of vapor bubbles in the liquid flow stream) which can damage the control valve and downstream piping. The recirculation valve remains closed during normal plant operation, which means it must provide tight shutoff to prevent clearance flow damage and to minimize any lost energy caused by excessive pumping requirements. Tight shutoff (ANSI/FCI 70-2 Class V) is normally specified on the recirculation valve. However, if the focus shifts to the boiler startup and regulator valves, specification of tight shutoff varies. In most conventional and some combined cycle feedwater level control loops, there is

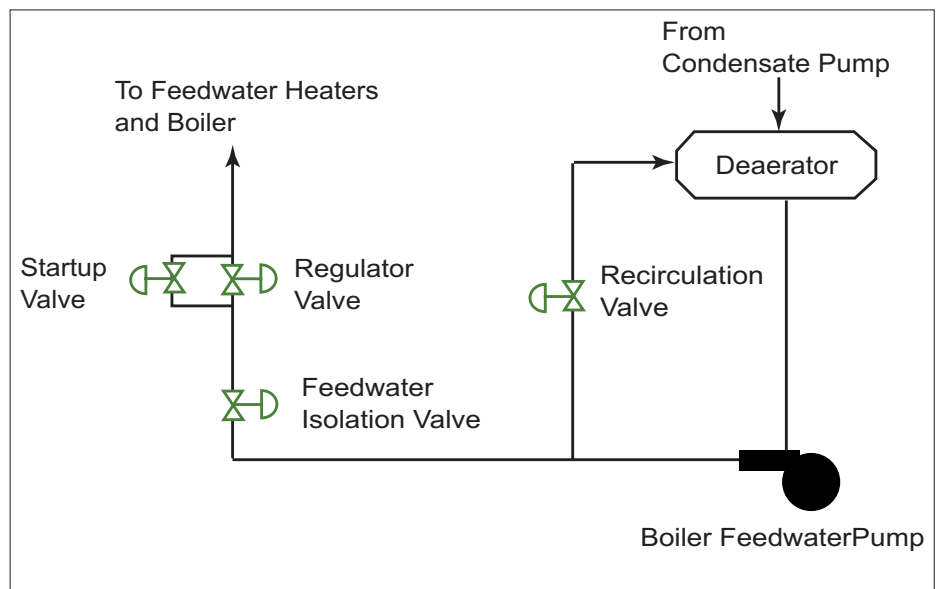

Figure 1. Schematic of a feedwater system

a combination of a startup valve used initially to fill the boiler drum and a regulator valve that is responsible for maintaining drum level during normal operation.

## Moderate shutoff and the forgotten valve

During initial operation of the unit, the boiler drum is under minimal pressure. The startup valve is used to fill the drum and pressurize the unit. Similar to the recirculation valve, it must withstand high pressure drops and the potential for cavitation. Once the drum is pressurized to a point where damaging cavitation in the regulator

valve cannot occur, the flow is transferred from the startup valve to the regulator valve. The startup valve closes and drum level is controlled by the regulator valve.

The typical feedwater system (Fig. 1) incorporates an upstream isolation valve to protect the startup and regulator valves when the pump is operating and flow is recirculated back to the deaerator.

As previously discussed, the startup valve is used to fill the boiler during initial operation. The control then transfers to the feedwater regulator valve. Because of the potential for

ANSI/FCI 70-2 Leakage Class	Leakage Rate for 3" Valve	Leakage Rate for 4" Valve
Class II (0.5% of valve capacity)	4.653 gpm	40.00 gpm
Class IV (0.01% of valve capacity)	0.08 gpm	1.086 gpm
Class V (0.0005 ml/psi/mm)	0.0015 gpm	0.0370 gpm

Table 1. Valve leakage comparison

cavitation, the startup valve often is specified with at least Class V shutoff. However, since the regulator valve does not experience cavitation during normal operation, it typically is specified with a lower leakage class, namely Class IV or less. While it is true that the regulator valve does not experience cavitating conditions during normal operation, it can experience cavitation when the startup valve is operating. When flow is transferred from the recirculation valve to the startup valve, there is full pump pressure on the inlet of both the startup and regulator valves and minimal pressure on the downstream side. If any water leaks through the regulator valve, it will cavitate and damage the valve assembly.

### Small leak, big deal

Leakage flow may not seem like much, but the amount of leakage needs to be explained. Let's assume the feedwater pressure is 3000 psig, and the system is composed of a 3" startup valve (16.5 Cv maximum) with full cavitation protection and a 4" regulator valve (165 Cv maximum) with an equal percentage characteristic. Calculating the leakage during initial operation when there is minimal pressure downstream of the valves shows a startling difference. Table 1 shows the difference in leakage rates between Class V, Class IV and Class II leakage.

As can be seen by the leakage rates in Table 1, if the 4-inch regulator valve is supplied with Class IV shutoff, the valve will be leaking over one gallon per minute while the fill valve is operating. Because of the high pressure drop, the fluid will be cavitating also, which will damage the valve trim and body. Class II leakage is shown because as the regulator valve is continually exposed to the high pressure differentials and subsequent cavitation damage, the leakage rate will continue to increase. This excessive amount of leakage can drastically affect startup of the unit. It makes it difficult to control the drum level during startup and makes controllability during transfer between the two valves difficult in terms of maintaining drum level. Once the transfer has occurred, it will affect the control scheme of the unit and can lead to high level alarms and a possible unit trip.

A recent example of an installation identical to that shown in Figure 1 had a startup valve provided with Class V shutoff and a regula-

tor valve provided with Class IV shutoff. After six months of operation, the regulator valve delayed three startups because of high level alarms during transfer between the startup and regulator valves.

When the valve was opened for inspection, severe cavitation damage was found. After reviewing the application and operating procedures, the damaged trim was replaced with trim that provided Class V shutoff. Since the installation, the plant has not experienced any additional issues with leakage or control between transfer of the startup and regulator valves.

Another side effect can occur in smaller plants. If an isolation valve is not provided upstream of the startup and regulator valve, the leakage through the regulator valve eventually can fill the boiler drum. If the boiler is not in operation, the treated feedwater will have to be dumped to the waste water system, leading to increased chemical treatment costs. Because of the large amount of leakage and possible valve damage associated with

*If any water leaks through the regulator valve, it will cavitate and damage the valve assembly*

this leakage, tight shutoff (Class V or better) is recommended for these applications. If isolation valves are used for shutoff, separate isolation valves should be used for each valve. Another solution is to combine fill and regulating functions into one valve with tight shutoff. This is accomplished by incorporating a characterized trim into the valve assembly. Trim characterization provides cavitation protection during initial operating conditions when the occurrence of cavitation is likely. Then, when normal operating conditions are reached, the trim provides greater capacity with less cavitation protection.

### The other leakage culprit

Even if the feedwater valves are supplied with Class V shutoff, there is still the possi-



Figure 2. Valve plug damage due to low-lift erosion

bility that leakage can occur. Many times this is due to operating the valves outside of their intended operating range. Valve leakage that develops over time often can be traced to continued low travel operation in the recirculation, startup and regulator valves. When the valve is operating at low travels (typically 10% or less) the possibility of what is called 'low-lift erosion' increases. The flow going past the plug and seating surface can lead to material erosion due to the large amount of energy available in the water. In older plants where pipe scale and other entrained particulate can be found in the feedwater lines, low-lift operation can be similar in effect to sand blasting the trim components. Figure 2 shows a picture of a valve plug with low-lift erosion damage; notice the wear marks on the tip of the valve plug and cavitation damage on the bottom of the plug. There are several ways to prevent low-lift erosion. One is to eliminate the possibility of leakage between the valve plug and cage. This can be accomplished by matching the dimensions of the plug and cage thus minimizing the tolerances between the two components. However, material selection is key to ensure that one component does not possess a significantly different coefficient of thermal expansion. If the wrong material is selected, binding can occur that will render the valve useless.

Another solution utilizes a metal piston ring around the lower portion of the valve plug. This device virtually eliminates clearance flow and also reduces lateral vibration, which extends seal and packing life.

The best way to avoid low-lift erosion is to begin with a review of the feedwater system.

In many plants, the startup valve is operated until the capacity of the valve is exhausted.

At this point, a minimum signal is supplied to the regulator valve causing the plug to be just cracked off the seating surface. Because of the minimal flow area exposed, the high velocity fluid can cause severe erosion to the plug and seating surfaces in a short amount of time.

When these two-valve systems are initially selected, they are selected on the basis that the valves would be operated in a manner where this effect did not occur.

The best transition between the two valves is what is commonly referred to as the 80-20 rule. In this case, the capacity of the startup valve at 80% travel matches that of the regulator at 20% travel. When the desired drum pressure and flow is attained, control from the startup valve should give way to the regulator in a seamless fashion to eliminate the possibility of a spike in feedwater level.

In most control systems this is accomplished by having the startup valve in automatic control during unit startup. When the capacity of the startup valve is nearly

exhausted, the regulator valve is opened to a set position that will not cause a drastic change in flow. Automatic control is then shifted from the startup valve to the regulator valve and the startup valve is set to close. This process takes place in a manner of minutes to minimize the valves' exposure to low flow erosion effects. The use of a digital valve controller will ensure that the valve will not operate in areas where low-lift damage is possible. A smart positioner can be programmed to allow the valve to stroke to a specific minimum throttling point. If the drive signal to the valve is less than this minimum value, the valve either will remain at the minimum operating point or go completely closed to protect against low-lift erosion. Because of the severe nature of feedwater applications, tight shutoff is one of the best ways to protect the valves from serious damage that can cause a maintenance headache and can affect the performance of a power plant. By properly assessing the operation of the feedwater system, one can be sure that the valves

will not be exposed to operating conditions outside of their specified construction. If problems do arise in the field, ensure that the valves are being operated in their specified ranges. Operation outside of these ranges can lead to severe valve damage in a short amount of time. ■

#### About the author



John Wilson is a Severe Service Sales Engineer with Fisher Controls International, Inc. in Marshalltown, IA, and carries a B.S. in Chemical Engineering

from the University of Nebraska. For the past four years, he has worked extensively on severe service applications focused on the Power Industry. Prior to joining Fisher Controls, Mr. Wilson worked for the Omaha Public Power District and the Nebraska Boiler Company.