

Ethylene Production

NOTE: The following chapter is the first of many to be released as part of a Chemical sourcebook. These chapters will be released to eDocs as they are completed and when fully developed, compiled into one sourcebook.

Ethylene is one of the most important petrochemical intermediates and is a feedstock for many various products. End products made with ethylene include food packaging, film, toys, food containers, bottles, pipes, antifreeze, carpets, insulation, housewares, etc. Chemicals that are made from ethylene in order to produce these end products are polyethylene, ethylene dichloride, ethylene oxide, ethylbenzene, and vinyl acetate, just to name a few.

Global ethylene capacity utilization has remained above 90% since 2004 until 2008's economic meltdown. In 2007, 2 million tonnes per year (tpy) of ethylene capacity was added, according to the *Oil & Gas Journal*. As of January 1, 2009, global capacity was 126.7 million tpy. Capacity has been added in recent years due to expansions and

debottlenecking at existing plants, as well as greenfield plants being built in the Middle East and Asia. Due to the change in market conditions and the economy, there is an over-supply of ethylene capacity. Many plants have been taken offline in this time period, are operating at reduced rates, or are undergoing turnarounds. As the ethylene market rebounds, capacity will increase. In fact, based on new capacities announced and plants that are under construction, global ethylene capacity is expected to be at 162 million tpy by 2012, ahead of the demand growth.

There are five major licensors of ethylene plants: KBR; Technip; Linde; Shaw, Stone & Webster; and Lummus. While ethylene production differs slightly by licensor, the overall process is fairly similar (see Figure 1-1). There are also some differences in the process coming from the type of feedstock being used. Some of these differences will be highlighted. This chapter will cover the general steps in ethylene production and will discuss the critical valve applications within an ethylene plant, what valve challenges those applications present, and the recommended Emerson solutions.

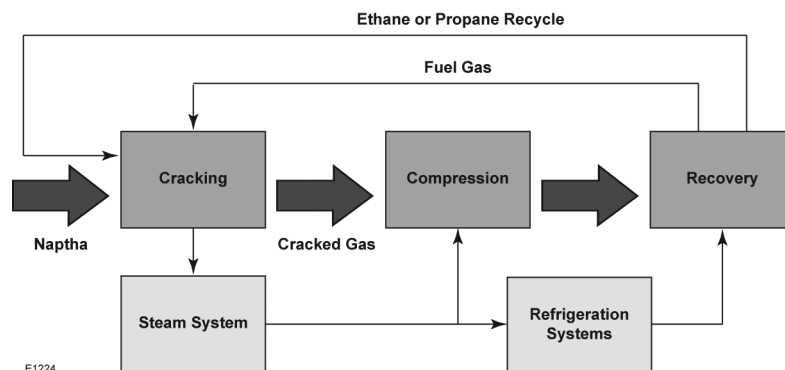

Figure 1-1. General ethylene process (naphtha fed cracker)



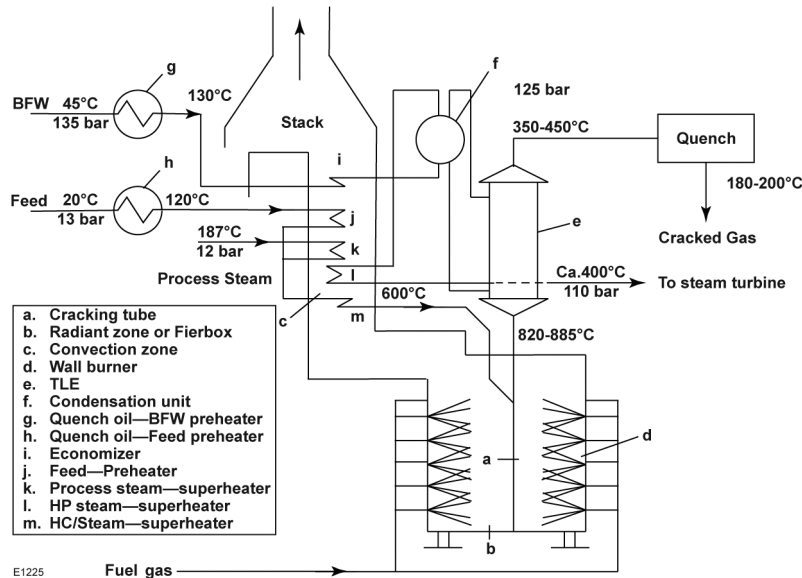

Figure 1-2. General ethylene furnace schematic

I. Furnace

The two primary feedstocks for ethylene production are naphtha and natural gas (ethane, propane, butane, etc.). The first step in the production of ethylene is to take the feedstock and crack it into ethylene and other various products in a furnace. This process is called pyrolysis. Pyrolysis is the thermal cracking of petroleum hydrocarbons with steam, also called steam cracking. The main types of commercial furnaces are the ABB Lummus Global furnace, Millisecond furnace (KBR), Shaw™ furnace (ultraselective cracking furnace), Technip furnace, and the Linde PYROCRACK™ furnace. See Figure 1-2 for a general schematic of an ethylene furnace.

The feed hydrocarbon stream is pre-heated by a heat exchanger, mixed with steam, and then further heated to its incipient cracking temperature (932°F to 1256°F or 500°C to 680°C depending upon the feedstock). At this point, it enters a reactor (typically, a fired tubular reactor) where it is heated to cracking temperatures (1382°F to 1607°F or 750°C to 875°C). During this reaction, hydrocarbons in the feed are cracked into smaller molecules, producing ethylene and co-products.

The cracking reaction is highly endothermic, therefore, high energy rates are needed. The cracking coils are designed to optimize the temperature and pressure profiles in order to maximize the yield of desired or value products. Short residence times in the furnace are also important as they increase the yields of primary

products such as ethylene and propylene. Long residence times will favor the secondary reactions.

Table 1-1. Furnace Reactions

Primary Reactions		Secondary Reactions		
Feedstock/steam	➔	Ethylene	➔	C ₄ products
		Propylene		C ₅ products
		Acetylene		C ₆ products
		Hydrogen		Aromatics
		Methane		C ₇ products
Etc.	Heavier products			

Maximum ethylene production requires a highly saturated feedstock, high coil outlet temperature, low hydrocarbon partial pressure, short residence time in the radiant coil, and rapid quenching of the cracked gas. Valves in the furnace section play a critical role in maximizing ethylene production and throughput.

There are three critical control valve applications in the furnace area: dilution steam ratio control, feed gas control, and fuel gas control. Each will be discussed in further detail in the subsequent text.

Dilution Steam Ratio Control

The quantity of steam used (steam ratio) varies with feedstock, cracking severity, and design of the cracking coil. Steam dilution lowers the hydrocarbon partial pressure, thereby enhancing the olefin yield. Because of this, it is important to obtain the appropriate ratio and maintain proper

control of that ratio. Steam helps to reduce coking deposits by reacting with coke to form carbon dioxide (CO₂), carbon monoxide (CO), and hydrogen (H₂) and also reduces the catalytic effect of the reactor coil's metal walls, which tend to promote coke formation. An improper ratio reduces efficiency of the cracker and can result in the need for more decoking cycles, thus resulting in less furnace uptime. It is necessary that decoking be performed on a regular basis. This is typically done by burning out the coke with a mixture of steam and air. Time intervals for decoking will depend upon several factors including, but not limited to the type of furnace, how the process is operated, feedstock type, and the types of coils utilized.

Precise control of the steam dilution valve is necessary to maintain the proper steam ratio, which can greatly affect the efficiency of the furnace. Due to the process conditions seen by the dilution steam control valve, it requires the use of graphite packing. Graphite packing often leads to higher friction than one would see with the use of PTFE packing. This added friction contributes to high deadband and high variability, thus the loop may become unstable. With high deadband and variability, it's difficult to have precise control within the valve, which leads to issues controlling the loop. Due to the location of the valve (near the furnace), high ambient temperatures are possible, thus making the location a variable to consider when selecting the actuator and related accessories.

The Fisher® control valve solution for the dilution steam ratio control valve is typically a Fisher easy-e™ sliding-stem valve or a Fisher GX sliding-stem valve. Because of the friction concerns mentioned previously, graphite ULF packing is recommended. This packing meets the process temperature requirements and has much lower friction than standard graphite packing. A spring-and-diaphragm actuator should also be used as they are proven to provide precise control in the field as well as in Fisher valve testing facilities.

The use of a Fisher FIELDVUE™ digital valve controller with Performance Diagnostics (PD) can be utilized to monitor control valve assembly performance and allow for predictive maintenance. When the performance is degrading, the next time the furnace is brought down for maintenance (typically decoking), valve maintenance can be scheduled ahead of time to bring the valve assembly back to an optimal performance level.

Feed Gas Control

The feed into an ethylene furnace can be ethane, propane, butane, gas oil, or naphtha. Variation in the type of feedstock used is related to availability. Plants in the Middle East tend to use natural gas feedstock because it is plentiful in the region and is a low cost feedstock. Asia has a large availability of naphtha and, therefore, is inclined to use it more frequently as a feedstock. Plants can also be designed to handle different types of feedstocks, allowing them more flexibility to change based upon availability and cost.

The feed gas control valve controls the flow of feedstock used in the ethylene plant. Tight control of the valve is critical in the steam dilution valve so that the proper reaction ratio can be maintained within the furnace. Control of the reaction ratio of feedstock to steam will affect the reaction efficiency and percentage of conversion to ethylene. Due to the process conditions, the use of graphite packing is required. Graphite packing often leads to higher friction than with the use of PTFE packing. This added friction contributes to high deadband and high variability, thus the loop may become unstable in automatic. With the high deadband and variability, it's difficult to have precise control within the valve, which then leads to issues controlling the loop. Due to the location of the valve (near the furnace), it can see high ambient temperatures. This should be a consideration when selecting the actuator and related accessories. While most of these issues mimic those of the steam dilution valve, there is an additional variable to consider: the use of low emission packing to reduce the emissions of the feedstock for environmental and safety concerns.

The Fisher control valve solution for the feed gas control valve is typically an easy-e valve or GX valve. Because of the friction concerns mentioned and the desire to reduce emissions, use of Fisher ENVIRO-SEAL™ graphite ULF packing is recommended. A spring-and-diaphragm actuator should also be used as they are proven to provide precise control in the field and in Fisher valve testing facilities. A FIELDVUE digital valve controller with PD can be utilized to monitor control valve assembly performance and allow for predictive maintenance. When the performance is degrading, the next time the furnace is brought down for maintenance (typically decoking), valve maintenance can be scheduled ahead of time to bring the valve assembly back to an optimal performance level.

Fuel Gas Control

Fuel gas regulates the temperature of the furnace by controlling the fuel to the burners. Special temperature profiles are applied along the cracking coil to avoid long residence times at low temperatures. This is because low temperatures favor the oligomerization reactions involved in the formation of secondary products. Oligomerization is a chemical process that converts monomers to a finite degree of polymerization (i.e. products that are not desirable in ethylene production). Because special temperature profiles are applied, the temperature control of the cracker is critical. The goal is to maintain the optimum temperature in order to favor the desired primary reactions and produce the most ethylene possible.

Due to the nature of the fuel, many plants utilize emissions control packing to limit the emissions of the fuel gas. This is for environmental concerns as well as general safety concerns. As with the other valves in the furnace area, due to location, the fuel gas valve may also see high ambient temperatures. Depending upon on the ambient temperatures for each particular application, special care may need to be taken in selecting the actuator and accessories.

The Fisher control solution for the fuel gas control valve is typically an easy-e valve or GX valve. Due to emissions concern, use of ENVIRO-SEAL graphite ULF packing is recommended. A spring-and-diaphragm actuator should also be used as they are proven to provide precise control in the field and in Fisher testing facilities. A FIELDVUE digital valve controller with PD can be utilized to monitor control valve assembly performance and allow for predictive maintenance. When the performance is degrading, the next time the furnace is brought down for maintenance (typically decoking), valve maintenance can be scheduled ahead of time to bring the valve assembly back to an optimal performance level.

II. Quench Tower

Cracked gases leave the furnace at 1382°F to 1607°F (750°C to 875°C). The gases must be cooled immediately in order to preserve the current composition of the gas and prevent undesirable side reactions from taking place. These side reactions are generally the secondary reactions listed in Table 1. The quench tower can



Used with permission of Genos Pty Ltd

Figure 1-3. Quench tower

use either quench oil or quench water. Generally, only quench water is used on natural gas-based systems whereas naphtha plants use quench oil and may use a quench water tower as well.

For situations in which a quench oil tower is being used for a naphtha fed plant, the quench oil is an extremely erosive fluid. It is usually dirty with entrained carbon particles. In order to have a long-lasting solution, the erosive nature of the fluid must be taken into account when selecting an appropriate valve.

The Fisher V500 eccentric plug rotary control valve is a well-suited solution for this application as it was specifically designed to control erosive, coking, and other hard to handle fluids. It should be operated in the reverse flow position for erosive service as this will help move the downstream turbulence away from the shutoff surface. For the quench oil application, a hardened trim should be applied, either Alloy 6 or ceramic. Ceramic trim is the typical solution. Sealed metal bearings are available to help prevent particle buildup and valve shaft seizure. The seat ring is reversible and will help improve the lifetime of the construction.

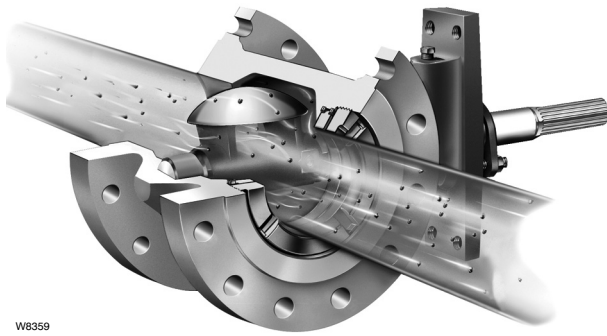

W8359

Figure 1-4. V500 eccentric plug rotary control valve

III. Cracked Gas Compressor

After the cracked gas has been cooled in the quench tower, the next step in the process is cracked gas compression. A turbine driven centrifugal compressor is utilized to perform this compression and there are typically four to five stages, with intermediate cooling. The number of stages necessary depends primarily upon the cracked gas composition and the temperature level of the cooling medium. All of the throughput of the ethylene plant will pass through a cracked gas compressor, so performance and reliability of this unit are especially important. The compressor is also an extremely expensive piece of equipment, resulting in a large percentage of the overall capital of the plant.

An antisurge control system is designed to protect this asset. The system is designed to provide a faster response than adjusting the turbine speed to control the onset of surge. The controller looks at multiple variables to prevent the onset of surge. It requires fast, accurate response in order to prevent surge conditions. The characteristics of a surge condition are fast flow reversal (measured in milliseconds), excessive compressor vibration, increase in flowing media temperature, noise, and it may cause the compressor to “trip”. Consequences of surge situations are substantial and may include shortened compressor life, loss of efficiency, reduced compressor output, and mechanical damage to seals, bearings, impellers, etc.

Antisurge control valves present many various challenges. The key challenge is ensuring valve reliability. There is an extended period between

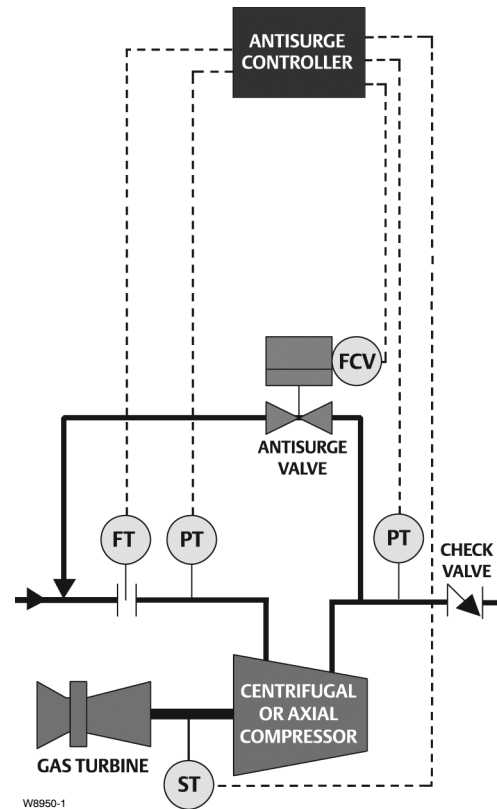

W8950-1

Figure 1-5. Antisurge control system

maintenance cycles and it is important to ensure a reliable control valve assembly solution. The antisurge valve is the main piece of equipment that protects the compressor from damage caused by a surge. When these valves are called upon to move, they are required to stroke very quickly, typically in the open direction only. For example, valves with travels up to 20 inches (50.8 cm) have been required to stroke in as little as 0.75 seconds. This can necessitate oversized actuator connections and the use of volume booster(s) and quick exhaust valve(s). The improper selection of these accessories will result in poor valve performance and tuning difficulties. During a surge event, the pressure drop and flow rate experienced by the valve can be high, causing excessive levels of noise. This must be considered in valve selection, although noise control throughout the entire range of valve travel may not be required. This valve may also be required to throttle intermittently from 0 to 100% open. These cases require the valve to have fast, accurate control for incremental step sizes. Any delays can cause a surge to occur. The antisurge valve must be able to pass the highest possible output capacity of the compressor. Application of a



Figure 1-6. WhisperFlo Trim cage

multiplying factor to the compressor capacity figure is common and may lead to selection of an oversized valve. Valves with too much capacity often have controllability issues and can cause unstable operation.

Emerson has developed an optimized antisurge package to meet the challenging demands of this application. Some highlights of this package will be discussed, but for more information, please see the brochure titled “Fisher Optimized Antisurge Control Valves”. These valves use a spoked plug versus the traditional balanced plug. With the traditional plug, when the valve is asked to move very quickly, there is not enough area in the balance holes to keep the plug in a balanced state; therefore, creating a differential pressure situation between the top and the bottom of the plug. This differential pressure case can lead to plug instability. The spoked plug has large balance areas so that this does not occur. For surge events where noise is a concern, a Fisher valve with a Whisper Trim™ III or WhisperFlo™ trim is recommended.

Emerson has the engineering capability to characterize these trims in order to meet the specific application needs and tailor a solution towards them. For situations when the valve assembly is called upon to move quickly, mechanical air cushions have been added to the actuator cylinder to provide controlled deceleration to help protect actuator and valve components.

The Fisher optimized antisurge package also includes a FIELDVUE digital valve controller with the Optimized Digital Valve (ODV) tier. There are features within this tier and ValveLink™ software to meet the needs of the application. For example, factory expertise is not required to tune the Fisher optimized antisurge valve. A technician can simply use ValveLink software’s performance tuner or the stabilize/optimize feature with real time graphics. Configuration and tuning can also be performed

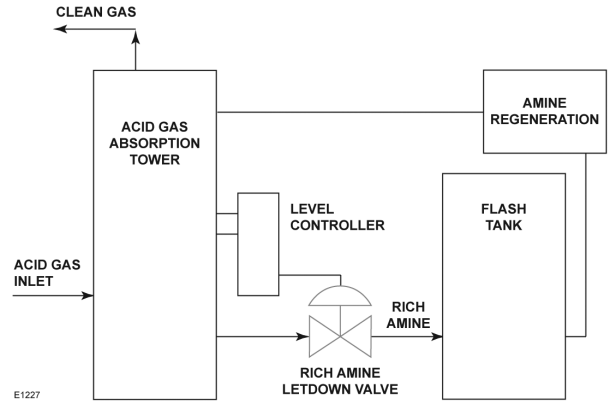

Figure 1-7. Rich amine letdown system

remotely by operators as process requirements change. This feature gives plant operators and technicians the capability to tune this assembly in the field. The lead-lag filter in the ODV tier can be used to improve the response to small amplitude steps by overdriving the set point. Asymmetric adjustments allow the response to be set independently in the open and closing directions. Integrated, real time graphics allow adjustments to be done remotely as well. Also, diagnostics can be collected, viewed, and analyzed using ValveLink software to look at items such as packing friction, air path leakage, actuator spring rate, and bench set. Partial stroke tests can also be performed to check the health of the valve and ensure the antisurge valve is going to move when it is requested to.

IV. Acid Gas Removal

The acid gas removal system is typically located between the 3rd and 4th or between the 4th and 5th stages of the compressor. In all process configurations, acid gas removal must be located upstream of the drying unit in order to avoid formation of ice and hydrates in the following fractionation steps. Acid gases are typically scrubbed on a once-through basis or in combination with a regenerative chemical. Regenerative pre-scrubbing, before a final sodium hydroxide treatment, is applied for high sulfur feedstocks. This will reduce the sodium hydroxide consumption. Regenerative scrubbing can employ alkanolamines. The use of alkanolamines should then require the use of a rich amine letdown valve as seen in Figure 1-7.

After any free liquids are removed from the gas at an inlet scrubber, the gas passes to the absorber

section. Here, it rises counter-currently in close contact with the descending amine solution. Purified gas leaves from the top of the absorber. Lean amine enters the tower at the top where it flows across trays and downward against the flow of the gas. At the bottom of the absorption tower, the acid gas rich amine leaves through the rich amine letdown valve that is actuated by a liquid-level controller. The rich amine then goes to a flash tank, operating at a reduced pressure, where large portions of the physically absorbed gases are offgassed. From there, the rich amine goes through various processes to be regenerated and the cycle starts over again.

The rich amine letdown valve is a demanding application because the process has entrained gas in solution. As the fluid passes through the letdown valve, it takes a pressure drop due to the pressure differential between the tower and the flash tank. As this pressure drop takes place in the valve, a large amount of outgassing occurs. Outgassing is when the entrained gas comes out of solution. As a result of outgassing, the valve has a two phase flow. One phase is the liquid amine and the other is CO₂ and/or hydrogen sulfide (H₂S) that comes out of solution. This two-phase flow may produce excessive vibration and may be very erosive due to high velocity impingement of the liquid phase on the valve trim.

Outgassing is very similar in effect to flashing and requires special consideration in the proper choice of valve, trim style, and materials. Generally, the overall approach is dependent on the severity of the pressure drop experienced. Although some sizing methods predict cavitation, small orifice anti-cavitation trim should not be used on this service for two reasons: first, the vapor cushions any cavitation bubble implosions and then cavitation damage should not be experienced and second, the accelerated gas breakout that, in turn, accelerates the liquid, would rapidly erode the multiple passage trim structure because of incompressible fluid impingement.

For pressure drops of 300 to 600 psi (20.7 to 41.4 bar), use of slotted (Whisper Trim I) or drilled hole (Whisper Trim III) trim styles installed in the flow up direction are recommended. The slotted or drilled hole cages “break up” the flow, minimizing the potential energy available to be dissipated during the outgassing process. Many relatively small sources of energy do not possess the damage capabilities of fewer large sources. By flowing the process fluid up, these small sources of energy are kept away from other critical trim parts. Standard hardened cage, plug, and seat



W0961

Figure 1-8. Whisper Trim I cage



W6787

Figure 1-9. DST

parts are recommended. For pressure drops over 600 psi (41.4 bar), use of a slotted Whisper Trim I cage made of solid Alloy 6 is recommended. A hardened valve plug and seat ring should also be used.

Other options for this condition include the use of a Fisher NotchFlo™ Dirty Service Trim (DST) valve or DST-G trim designed for outgassing. For all rich amine letdown applications, NACE materials are likely specified.

V. Drying

The cracked gas is saturated with water before compression and after each intercooler stage. Moisture must be removed before fractionation to prevent the formation of hydrates and ice. Temperatures of -148°F (-100°C) would form ice

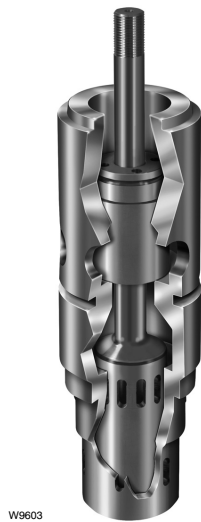

W9603

Figure 1-10. DST-G

compounds that could block pipes and/or damage equipment. Typically this is accomplished by chilling and by adsorption on molecular sieves. The drying process is similar to that of a two bed pressure swing adsorption (PSA) skid. Older plants also use absorption by a glycol scrubbing system or adsorption on alumina. Drying is arranged before the first fractionation step, typically after the last compression stage. Multiple adsorption beds make continuous water removal possible. One or more adsorption beds are in operation while at least one unit is being regenerated. The inability to dry because of molecular sieve issues will shut down the plant.

Generally, line-sized butterfly valves or quarter-turn ball valves are used in molecular sieve switching applications. Over-sizing can occur and high cycle demands will cause wear on the valves. As a result, galled bearings and seal wear will also occur. In the case of high output torque, bed lifting of the adsorption beads can occur if the valve is controlling poorly or opens too quickly and “jumps” out of the seat. This can damage the adsorption beads and cause them to rub or abrade together and create dust. This reduces the drying effectiveness of the adsorption beads. The dust or fines from bead wear can get stuck in the bearing area and cause damage. At the very worst, it can cause seizing of the valve. The adsorption bead dust or fines can also cause seal wear.

Emerson has experience and success in molecular sieve applications for the ethanol industry. Fisher A81 valves with a 316 SST chrome plated disc and UHMWPE seal technology

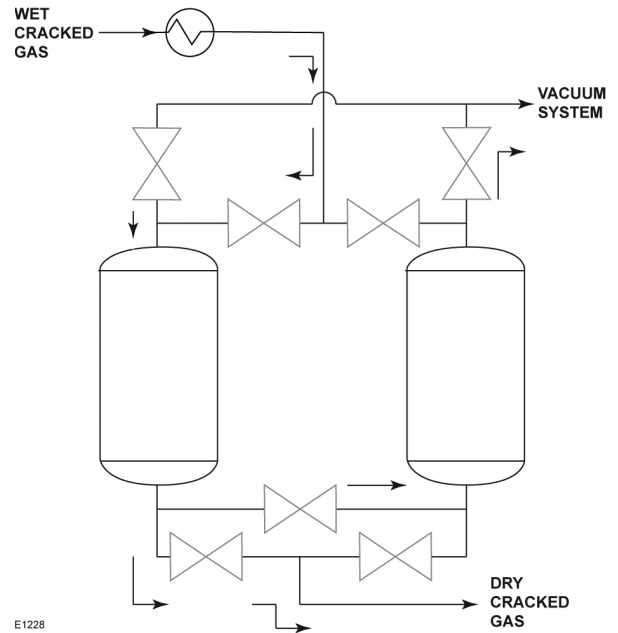

E1228

Figure 1-11. Molecular sieve drying system

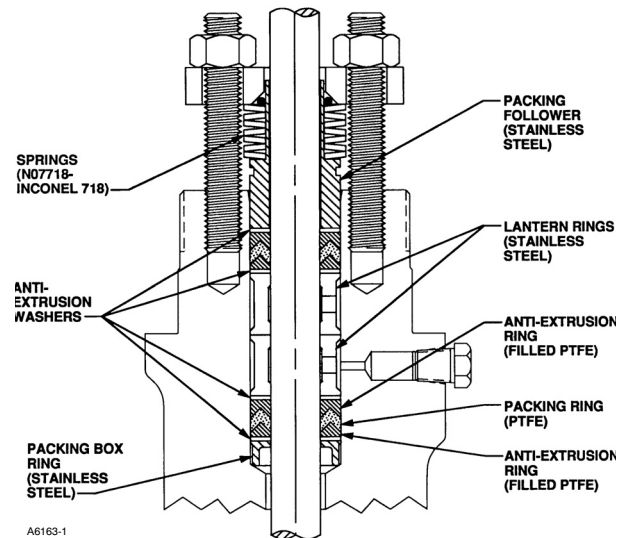

A6163-1

Figure 1-12. ENVIRO-SEAL PTFE packing system

have been used with good results. The UHMWPE seal allows for tight shutoff. Tight shutoff allows for improved bed drying. PTFE lined PEEK bearings should also be used as these have been shown in molecular sieve applications to last longer than wire mesh bearings. ENVIRO-SEAL packing may also be considered to avoid leakage of the cracked gas.

Use of a FIELDVUE digital valve controller can increase the response to set point at the beginning of the adsorption and regeneration cycle without

overshoot. It precisely controls the rate of opening to eliminate adsorption bead bed disturbance.

VI. Distillation Columns

The fractionation section receives the compressed cracked gas at a pressure of 464 to 551 psi (32-38 bar) for further fractionation into different products and fractions at specified qualities. This is done through a series of distillation columns and hydrogenation reactors. Cryogenic separation is the predominant method for cracked gas separation. Although gas separation processes via adsorption, absorption, or membrane technology have made progress in the recent past, they have not found major applications within the ethylene industry. Today, three processing routes have gained commercial importance, with the main characteristics being the first separation step and the position of the acetylene hydrogenation. These routes are demethanizer first with tail-end hydrogenation, deethanizer first with front-end hydrogenation, and depropanizer first with front-end hydrogenation. The following is a listing of the various distillation columns and their functions:

- **Demethanizer:** Demethanization of the cracked gas separates methane as an overhead component from C_2 and heavier bottom components. Concurrently, hydrogen is removed from the cracked gas stream and may be obtained as a product by purification before or after demethanization. Methane is typically used as a plant fuel or sold. C_2 and heavier components are sent to the recovery system.

- **Deethanizer:** Deethanization of cracked gas separates acetylene, ethylene, and ethane as overhead components from C_3+ bottom components.

- **Depropanizer:** Depropanization separates propane and lighter fractions as overhead components from C_4+ fractions as bottom components.

- **C_2 splitter or ethylene fractionation:** Ethylene fractionation separates ethylene as a high-purity overhead product from ethane, which is combined with propane and recycled for cracking.

- **C_3 splitter or propylene fractionation:** Propylene fractionation separates propylene as a chemical grade overhead product or more

frequently as polymer grade propylene from propane. Propane is recycled for cracking.

- **Primary fractionator:** With liquid pyrolysis feedstocks (naphtha fed plants), the primary fractionation column is the first step in the cracked gas processing route. Cracked gas enters the column and it is contacted with circulating oil and, at the top of the column, with a heavy pyrolysis gasoline fraction obtained from the subsequent water quench tower. Cracked gas leaves the top of the primary fractionator free of oil but still containing all the dilution steam. Hot oil, which functions as a heat carrier, is collected at the bottom of the column. After cooling, it is recirculated as reflux to the middle section of the primary fractionator and to the quench nozzles downstream of the transfer line heat exchangers.

Distillation columns occur in all types of chemical plants. The objective is to separate a feed stream into light-component and heavy-component product streams. It relies on the relative volatility between the components that make up the feed stream. The high volatility (lighter) components boil at a lower temperature than the low volatility (heavier) components. Therefore, when heat is added to the column through a bottom reboiler, the lighter materials are vaporized and rise to the top of the column. The overhead vapors are cooled until they condense and become a liquid again.

The efficiency of distillation depends on the amount of contact between the vapor rising and the liquid falling down the column. Therefore, some of the overhead liquid product is sent back (refluxed) to the top of the column. Increasing the reflux will improve the purity of the overhead product. However, it also requires more heat from the reboiler to re-vaporize the lighter components in the reflux stream. Some distillation columns can operate with a side reboiler as well, such as the demethanizer. The operation of a distillation column is a balancing act between product purity and energy usage. If the amount of vapor and liquid traveling through the column becomes too great, the column can "flood." Too much reflux, too much reboil heat resulting in too much vapor, or both can cause flooding. When flooding occurs, the efficiency of the distillation column is dramatically reduced with corresponding drops in product purities.

Figure 1-13 shows the general schematic of a distillation column. The valves associated with this are the feed, reflux, bottom product, overhead product, pressure control, and reboil valves.

Feed valves are usually used as flow or level control loops. An upstream unit or process often

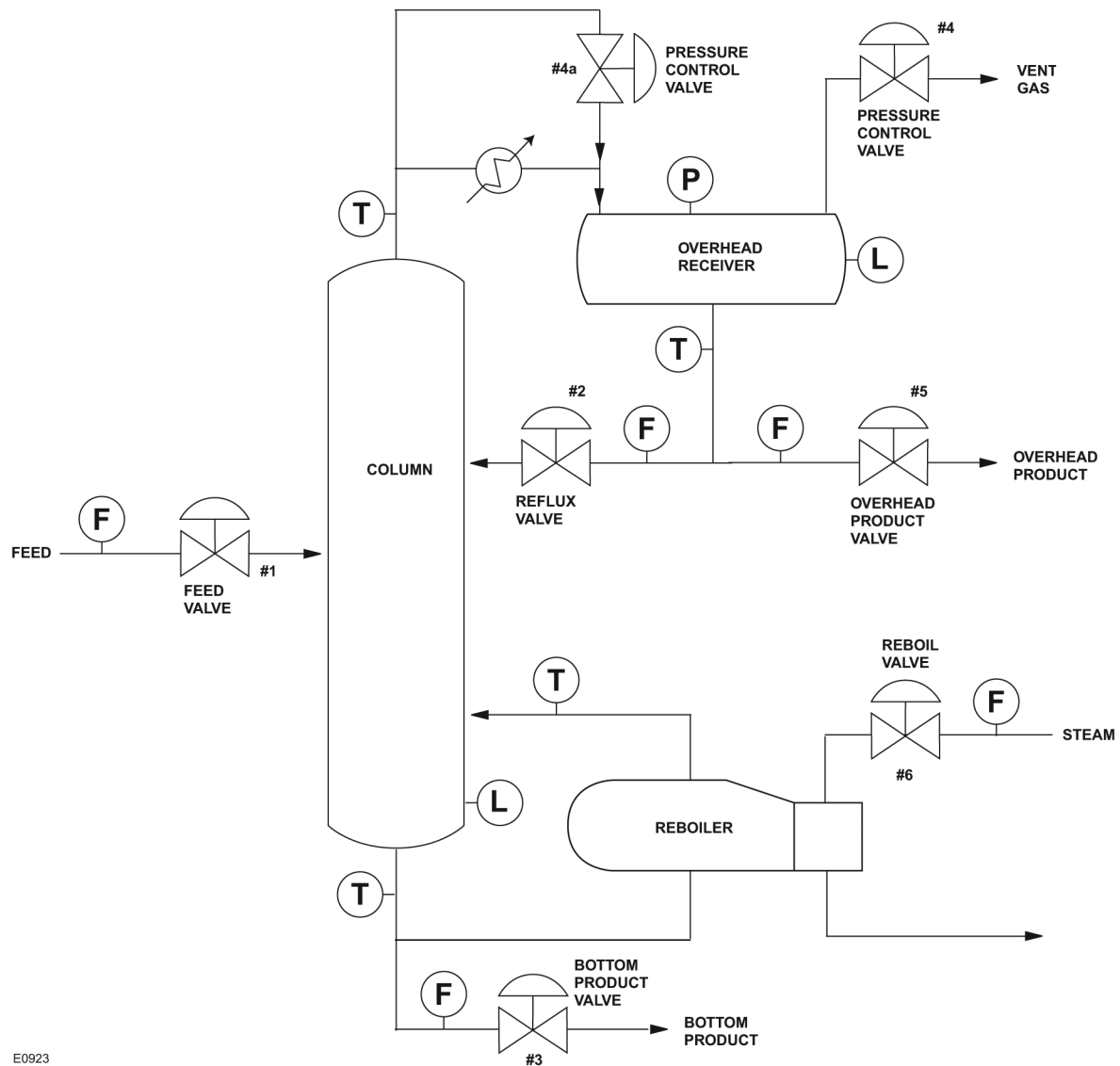

Figure 1-13. Schematic of a basic distillation column

controls the feed valve. Unstable feed flow will make the distillation column difficult to control. A problem valve will often cause the feed flow to oscillate. As a result, the column will alternate between too little and too much reboil heat. Depending upon the size and number of trays in the column, the effect of a swing in the feed will take anywhere from several minutes to more than an hour to reach the ends of the column. Sometimes, the reboil and reflux control will amplify the swings. As a result, meeting product purity targets becomes more difficult. Operations personnel will normally respond by over-purifying the products, wasting energy to compensate for the problematic feed control valve.

The reflux valve is typically either a flow or column temperature control loop. It is used to adjust the purity of the overhead product. The higher the reflux rate, the more pure the overhead product will become. However, raising the reflux rate requires more reboil heat and will eventually flood the tower. A poorly operating reflux valve has the same effects as a bad feed valve. Product purities will oscillate and the column will be difficult to control. This ultimately affects the efficiency of the column.

The bottom product valve is used to control the level in the bottom of the column. It can cause the level to change quickly and dramatically. Issues with this valve reduce efficiency or at worst, cause

flooding in the column. The overhead product valve is used to control the level in the overhead receiver. It can also cause the level to change quickly and dramatically in the column. Problems with this application can reduce efficiency.

Pressure control valves provide the back pressure to the column. This is very important for controlling the stability of the tower. Stable pressure is required to ensure that temperature changes reflect composition changes and not pressure changes. With too small of a valve, the pressure response will be very sluggish. Too large of a valve and small valve movement will cause a large pressure swing. Oscillating column pressure and difficult control result with either over- or under-sizing the valve.

The reboil valve controls the amount of heat put into the column by the reboiler. In many cases, steam is used as a heat source. The service is very clean and fugitive emissions are not a concern. Steam valves are usually very reliable; however, a problematic valve will make the column difficult to control precisely. This is especially true if the column feed is subject to frequent changes. Not all reboilers use steam though. Higher temperature process streams can also be used to provide heat for lower temperature processes such as using cracked gas streams.

Whichever distillation column application is being discussed, the control valve solution needs to provide accurate and reliable control. The valves can affect column efficiency, stability, column energy usage, flooding, etc. An easy-e valve or GX valve is recommended and are typically CF8M constructions. The demethanizer and deethanizer may require the use of cryogenic valve constructions. A FIELDVUE digital valve controller should be utilized to achieve tight control. Diagnostics are key in these applications for preventative maintenance since distillation columns have long periods between shutdowns, and loss of a distillation column will shut down the entire ethylene plant.

VII. Propylene and Ethylene Refrigeration

Refrigeration in ethylene plants is important and costly. Refrigeration optimization is vital in plant design. Typically, two different refrigeration systems are employed. The propylene and

ethylene refrigeration compression trains are the other two compressors in addition to the cracked gas. These compressors also have antisurge systems and, therefore, antisurge valves. The antisurge valve challenges and solutions are the same as highlighted in Section III: Cracked Gas Compressor, though it is important to note that valve sizes may differ for each compressor.

VIII. Hydrogen Purification

Hydrogen is produced in the cryogenic section of the plant. The purity is typically 80-95% volume. However, it contains approximately 1000 parts per million (ppm) of CO. It needs to be purified because CO is a poison for hydrogenation processes. One of the hydrogenation processes is the acetylene conversion to ethylene. Typically the ethylene specification requires less than 1 ppm of acetylene. The other hydrogenation process is MAPD (methylacetylene and propadiene) conversion to propylene and propane. This is done for economic reasons and to remove these components from the propylene product. The most common process for hydrogen purification is PSA.

The control valves used in PSA applications are in a very high cycle service, seeing 100,000 to 250,000 cycles per year. The valves and actuators are expected to stroke up to once every three minutes. The stroking speeds are required to be fast and controlled. Uncontrolled opening can cause pressure/flow spikes. Depending upon the type and size of a PSA skid, the amount and type of control valves will vary. PSA skids can use globe and/or rotary valves. Control valve shutoff is a major concern because it affects PSA unit efficiency. Bi-directional flow conditions will also exist. Also, if valve leakage causes contamination from one PSA bed to another, industrial gas purity can be compromised.

A GX valve is the recommended globe valve solution for PSA service. It can handle stroking speeds up to 1.5 - 2 seconds. Class VI shutoff is necessary and bi-directional shutoff is standard in this construction. Certified emission control packing is standard to reduce potential hydrogen leakage. The recommended high performance butterfly valve construction requires the use of a pressure assisted UHMWPE seal. PTFE lined PEEK bearings that can withstand long cycle life requirements are used. Live loaded PTFE ENVIRO-SEAL packing is available to reduce hydrogen leakage.

PSA BASIC FLOW SCHEME

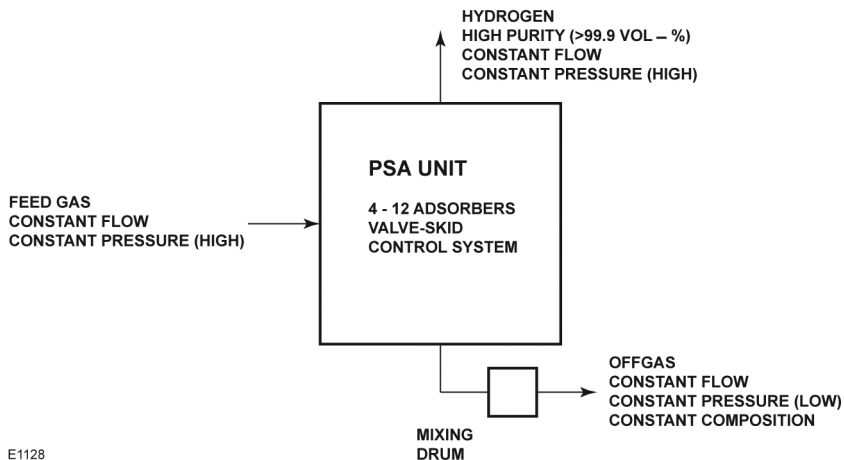

Figure 1-14. PSA basic flow scheme

These constructions have undergone extensive testing within the flow lab in Marshalltown, Iowa, United States to ensure that they meet the demands of PSA service. PSA testing is used to verify the life cycle of Fisher digital valves. PSA testing was designed and set up with input from major PSA licensors to represent the PSA process as accurately as possible. Both the GX and butterfly valve solutions have undergone rigorous testing to prove they can meet the high cycle demands of this service.

IX. Power/Steam Turbine

As with most process plants, there is a power side to the ethylene plant. The valve applications in this area are very similar to those seen in traditional power plants. The conditions may not be as severe but the applications and recommended solutions are very similar. Heat from the cracked gas is recovered through a Heat Recovery Steam Generator (HRSG) to generate steam. Steam is used to run turbines and for other processes within the plant, i.e. steam to the pyrolysis furnace. The HRSG system has a feedwater, condensate, desuperheating, and blowdown system. The critical valve applications are boiler feedwater recirculation, boiler feedwater start-up and regulator, continuous blowdown valves, and condensate recirculation.

The boiler feedwater system begins at the deaerator and ends at the inlet to the economizer. The main components are the deaerator, the boiler feed pump, and the high pressure feedwater

heaters. The main purpose of the boiler feedwater system is to condition the feedwater for entry into the boiler. The deaerator removes unwanted oxygen from the feedwater, which in turn prevents corrosion in the entire piping system. The boiler feed pump raises the pressure and the high pressure feedwater heaters raise the temperature of the feedwater. The critical valves within the boiler feedwater system are the boiler feedwater recirculation, feedwater startup, and feedwater regulator valves.

In order to protect the feed pump, there must be a recirculation system. The boiler feed pump recirculation valve takes feedwater from the boiler feed pump and recirculates it to the deaerator. It is there to protect the pump from cavitation and excess temperature rise. There are three basic methods of providing feed pump recirculation. Two older methods are continuous recirculation and on/off recirculation. The current method is modulating recirculation. This provides minimum recirculation flow to protect the pump and optimize efficiency. It requires a high technology recirculation valve.

The recirculation valve typically experiences cavitation and if not properly taken into account with valve selection, cavitation damage will result. Because of the cavitation, tight shutoff is required. Any fluids leaking past the valve will cavitate and cause damage to the seat. A leaking recirculation valve can cause decreased unit capacity, repeated maintenance, and repeated trim replacement. Plugging can occur if feedwater is not clean. A common issue with all feedwater applications is corrosion due to materials chosen. Amine or hydrazine treated feedwater is corrosive to Alloy 6.

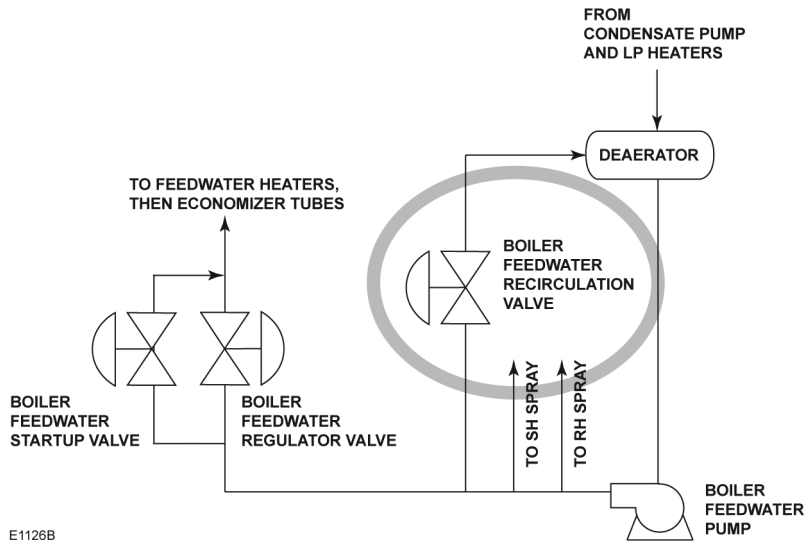

E1126B

Figure 1-15. Boiler feedwater recirculation valve

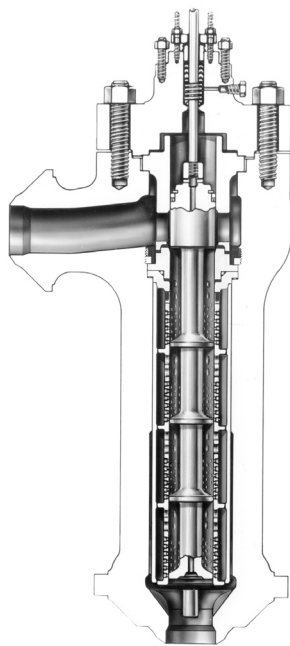

W5662

Figure 1-16. Cavitrol IV trim

If the feedwater is treated, use of this material should be avoided.

It is important to select a valve that can combat damaging cavitation. Typical recommendations for this application include an easy-e sliding-stem control valve or a Design EH or HP globe valve with Cavitrol™ III trim. For extremely high pressure drops, Cavitrol IV trim can be used.

In the case of unclean feedwater with particulates, a Fisher NotchFlo DST valve is an optimal choice

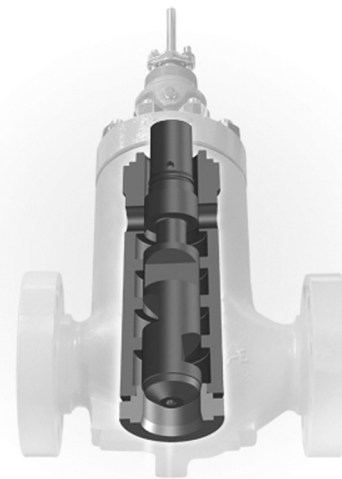

W8433

Figure 1-17. NotchFlo DST valve

because it has the ability to minimize cavitation and allows for the passage of particles to prevent clogging. In the case of treated feedwater, 440C is the recommended material.

The feedwater startup and feedwater regulator applications will be discussed separately. However, it is not uncommon to see these two applications combined into one valve. The feedwater startup valve is used to initially fill the boiler. Depending upon the design, this can be through the main feedwater pumps or the condensate pumps. The valve transitions operation to the feedwater regulator valve, or variable speed drive, once drum pressure has been built up.

During drum fill operation, the boiler is under minimal pressure. This causes the entire pressure drop to be taken across the feedwater startup valve. Because of this, the formation of cavitation becomes a concern. Sizing of the startup valve must be done in combination with the feedwater regulator valve. This is to ensure that the feedwater regulator valve does not experience any service conditions that lead to damaging cavitation. The most common split is that 80% capacity in the startup valve is equal to 20% capacity in the regulator valve. Once the transition to the regulator valve has begun, the startup valve closes. Improper use is one of the main issues surrounding two valve feedwater systems. For example, the startup valve is not being used at all and the regulator valve is being used to perform both functions. This can be a major problem if the boiler feedwater regulator was not sized or selected to perform both functions. There can also be an issue if switching between the startup and the regulator valve is happening too quickly.

Because of the cavitation concerns and taking the full pressure drop, the startup valve should utilize some form of anti-cavitation trim. Typically, in process plants, since the pressures are not as high as power plants, Cavitrol III trim is selected. 440C trim is recommended for the case of treated feedwater. For cases where one valve is performing the startup and regulator duties, characterized Cavitrol trim can be designed to handle the cavitating conditions at startup and then standard equal percentage or linear characteristic for steady-state conditions to maximize capacity. Another common issue in both the startup and regulator valves is to see them operated below the minimum operating point. This can cause "gear-toothing" damage on the plug. Damage can be limited by utilizing a lower metal piston ring or matched plug/cage combination. This limits the amount of clearance flow between the plug and cage thus minimizing erosion effects. Another solution is to use the protected inside seat technology with Cavitrol III trim. This technology is designed so that the shutoff surface is not exposed to potential erosion. Protecting the shutoff surface will extend the sealing life of the trim. Using the low travel cutoff feature of the FIELDVUE digital valve controller is ideal. The instrument can be setup so that the valves do not throttle below a minimum point.

The continuous blowdown application is constantly removing concentrated water from the drums and removes a significant level of suspended solids. Typically, this application is flashing. Flashing is a system phenomenon and, therefore, cannot be

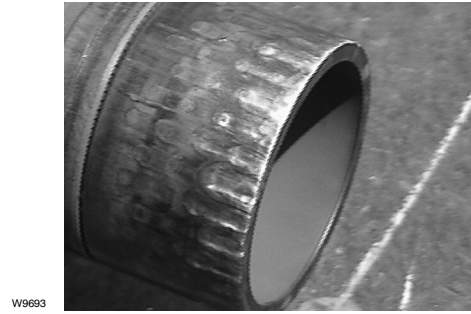

Figure 1-18. Gear-toothing

prevented. The best way to handle it is to minimize the amount of damage being caused by flashing. Use of an angle valve with a downstream liner is recommended to minimize the amount of damage caused by flashing. It is much more economical to replace a liner than to replace an entire valve.

The condensate recirculation valve is similar to the feed pump recirculation valve in that it also protects the pump from cavitation. Inlet pressure and temperature differ from the feedwater system. The dissimilarities from the feedwater system include the inlet pressure and temperature. Inlet sizing often indicates that flashing is occurring. The end user needs to ensure that there is not a sparger or diffuser downstream emitting back pressure on the valve. This will cause cavitation rather than flashing. Cavitation can also cause noise and vibration. Tight shutoff is needed on this application because it prevents loss of condenser vacuum, loss of condensate pressure and flow to the deaerator, and saves money in terms of wasted pump horsepower. Valve selection is typically an EWT valve with Cavitrol III trim. Flow is usually 25-35% of the condensate pump's full capacity. Class V shutoff is highly recommended to minimize leakage past the seat because it can cause damage.

X. Flare System

In an ethylene plant, vent to flare systems are on several of the unit operations such as the quench tower, distillation columns, steam systems, etc. Vent valves are used to depressurize the unit for safe shutdown and, possibly, for startup as well. Due to the high pressure drop and high mass flow, they are severe service applications. They are also critical reliability applications as part of the safety shutdown systems. These valves are closed except in flare scenarios. Plant personnel need to ensure that the valves move when the process requires flaring.

The first challenge for vent valves is to have optimum sizing and selection of the valve with a silencer/diffuser. It is a balancing act when sizing this system as a result of optimizing the noise attenuation by adjusting how much pressure drop each component is taking. Because they directly affect each other, they should be considered an engineered solution and sized together as a system. Tight shutoff is a major concern as any leakage causes a loss in plant efficiency. Class V seat load is recommended as it will minimize leakage past the vent valve while in the closed position. This is usually a high noise application due to the pressure drop and high mass flow. Operation may be intermittent and for a short duration so high noise may be tolerable. Awareness and concern for structurally intolerable noise levels are necessary. Noise requirements are likely to be driven by plant and regulatory noise requirements.

Globe or angle valves with a Whisper Trim III or WhisperFlo trim for noise attenuation, are the typical recommendation for this application. There are some exceptions to this. Vent valves on the quench tower may be able to use butterfly valves with diffusers due to the low pressures in this particular application. Also, cryogenic valves may be needed on some of the distillation column vent

valves. Because this is a valve that normally sits closed but needs to move when called upon, the FIELDVUE DVC6000 SIS (Safety Instrumented Systems) is an optimized solution. As plants are paying more attention to their safety loops and performing safety evaluations, these are being tagged as SIS applications because they are key to ensuring that the process can flare in the event they are needed (shutdown, startup, and emergency event). Partial stroke testing can be performed using the DVC6000 SIS. This can be done without interrupting normal operation and requires the valve to move from 1 to 30% of its total travel.

XI. Conclusion

Ethylene plants use hundreds of control valves throughout the entire production process and understanding the various applications is essential in order to apply an engineered solution towards them. With the selection of an appropriate Fisher control valve solution, plant performance will improve as a result of enhanced reliability, variability, safety, etc.

Polysilicon Production

I. Overview:

Polysilicon, or polycrystalline silicon, is a key component used in the production of many electronic devices used today including computers, cell phones, game consoles, PDAs, mp3 players, car and home electronics, digital cameras, medical devices, etc. Polysilicon is formed to make ingots, wafers, fabricated wafers, and integrated circuits. It is then manufactured into necessary parts. Polysilicon is also a key component in the production of solar cells for solar power. The solar energy market is growing as producers come closer to reaching the level of grid parity. Grid parity is the cost at which photovoltaics are competitive against other forms of electricity generation. Once grid parity is reached, demand for photovoltaic products will increase significantly.

There is not just one type or grade of silicon or polysilicon. A supplier may classify the polysilicon produced into fifty or more different grades with different specifications unique to the user and the application. However, this chapter will only refer to three main types:

- Metallurgical grade silicon (MG-Si) is 95-99% pure and it is produced from quartz crystals.
- Solar grade polysilicon is approximately 6N to 7N pure.
- Electronic or semiconductor grade polysilicon is the purest form at grade 9N to 11N.

In referring to purity levels of polysilicon, it is common to use the number of nines past the decimal point, i.e. 6N pure is actually 99.999999%.



W9770

Figure 2-1. Silicon Wafers

Polysilicon has historically been a cyclical market. There are times when capacity addition cannot meet rising demand. At other times, oversupply is a concern. Market fluctuations do not greatly affect established industry and larger downstream customers as they generally work on long term contracts, typically five to eight years. Major producers of polysilicon include REC Silicon, Hemlock Semiconductor, Wacker-Chemie, and Tokuyama. The market was in a period of extreme demand in 2006-2007; however, analysts are currently predicting an oversupply beginning sometime in 2010. Research by Photovoltaic-Tech in March of 2009 shows there has been an over 50% increase in polysilicon capacity from major producers through 2012, compared to just nine months earlier. A conservative model of the future polysilicon market, taking an adjustment for grid parity, was presented by Hemlock Semiconductor VP Gary Homan in *Photovoltaics International*. It shows a growth of polysilicon in the 3.3x range from 2008 to 2014, or an increase from 64,000 to 209,000 metric tons (MT) in thousands. The rapid rate of market growth means that periods of oversupply are short-lived (typically one to three





W9771

Figure 2-2. Solar Panels

years); however, various complex factors influence this trend.

Government incentives have a major effect on market needs as interest in using solar power as an energy source continues to grow. The economic viability of solar power has been critically dependent upon a state subsidy of some form. This mainly occurred in Japan and Germany but was used in Spain in 2008 as well. It also depends upon the grid prices of conventional electricity in the region. The American Recovery and Investment Act includes over US\$6 billion in loan guarantees for renewable energy projects, solar in particular. Industry representatives have

estimated the bill will create a total of 119,000 jobs between 2010 and 2011. Analysts also anticipate grid parity to exist in a number of large markets between 2012 and 2015 at which point government incentives are no longer necessary to support additional capacity installation.

Two major production processes are used to make polysilicon:

- Siemens process
- Fluidized bed reactor process.

This chapter will discuss each of them separately. Critical valve applications and special considerations for valves used for polysilicon production will also be discussed.

II. Siemens Process:

The Siemens process, or a modified Siemens process, accounts for more than 90% of the global install base for polysilicon production. This process can be used to produce solar or semiconductor grade polysilicon. The general process is no longer protected but several technology suppliers do license their own specific variants to the process. There are three main steps to this process:

1. *Preparation and purification of trichlorosilane (or occasionally silane)*
2. *Chemical vapor deposition (CVD)*
3. *Recovery*

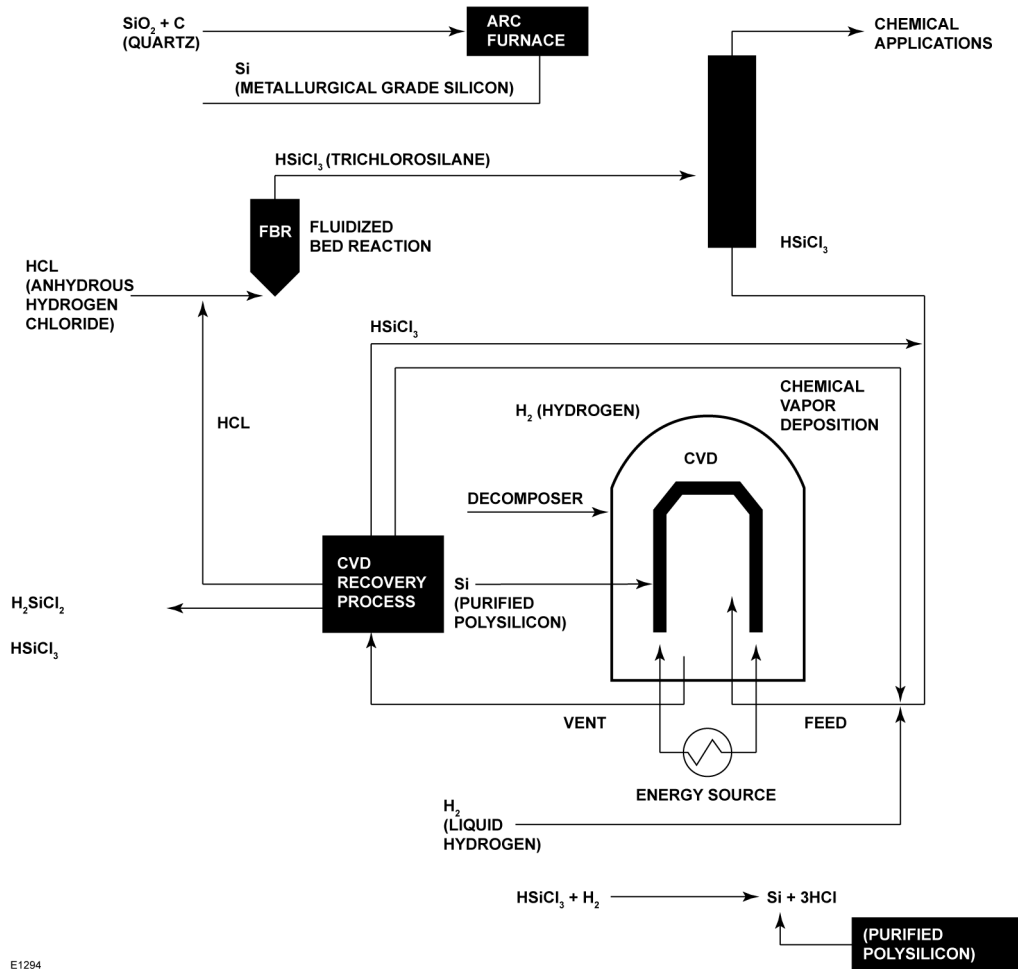
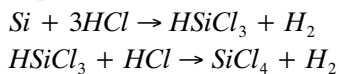

Figure 2-3. Generic Polysilicon Production Process

The general chemical reactions for the main steps of the Siemens process are shown below:

TCS production



Polysilicon production (CVD)

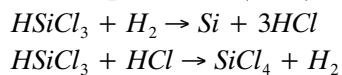

STC conversion

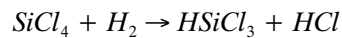

Nomenclature :

<i>Trichlorosilane(TCS) :</i>	HSiCl_3
<i>SiliconTetrachloride(STC) :</i>	SiCl_4
<i>Silicon :</i>	Si

Figure 2-4. Chemistry of the Polysilicon Process

Preparation and Purification of Trichlorosilane

In step one; silicon is converted to trichlorosilane (SiHCl_3), silicon tetrachloride (SiCl_4),

dichlorosilane (SiH_2Cl_2), or silane (SiH_4). Though chlorosilanes are more commonly used than silane, there is a major advantage to using silane as its deposition temperature is about two-thirds that of trichlorosilane. However, silane is not

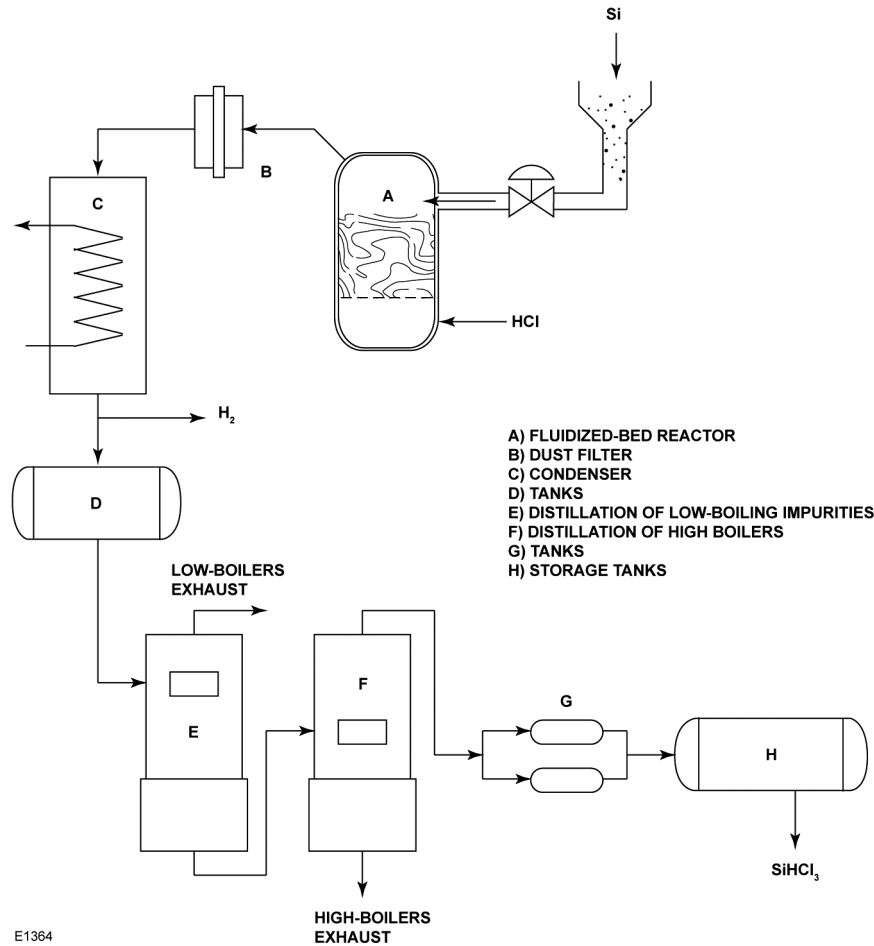

Figure 2-5. Flow Chart of the Preparation and Refining of Trichlorosilane

widely used because it is more difficult to work with and ignites spontaneously in air. Trichlorosilane is used as the feed material in approximately 75% of worldwide polysilicon production by the Siemens process. Chlorosilanes can be produced at the polysilicon manufacturing site or at a nearby plant and transported to the polysilicon site while maintaining the purity level of the fluid; however, larger polysilicon plants are typically producing their feed materials onsite or at an adjacent plant.

Dry hydrogen chloride (HCl) gas is passed through a heated MG-Si, particle sizes smaller than 40 μm , in a fluidized bed reactor. This is done at a HCl ratio of 1:3. The reaction takes place at around 600°F (315°C) and 500 psig (34.5 barg). The resulting chemicals of this reaction are a blend of chlorosilanes, hydrogen, HCl, and unreacted silicon. Two chlorosilane species predominate: trichlorosilane (TCS) at 90% and tetrachlorosilane, also referred to as silicon tetrachloride (STC), at 10%.

The TCS produced includes some contaminants of boron, aluminum, and phosphorous. These contaminants are removed in a multistage fractionation process. To ensure proper separation, TCS is cooled and the liquid is flashed through a multistage fractionation tower. In the first stage, hydrogen is separated and recycled back to the process. The first stage column bottom product is flashed through the second stage column where the TCS and STC are separated. The TCS is further purified through fractionation and other purification methods to get ultrapure TCS for use as the reactor feed. Typically, there are eight to ten purification towers installed in series for each plant. Sometimes complexing agents are used to remove phosphorous and boron chlorides from the process. Impurities are removed as metal chlorides in solution of TCS/STC. It is "impossible" to measure impurities at such low levels, so an over-design of the columns can occur and purity levels cannot be measured until the final product. TCS is typically stored in a tank and then fed to

the chemical vapor deposition reactors as necessary.

Chemical Vapor Deposition

Using chemical vapor deposition to produce polysilicon was first developed by Siemens and Halske in 1952 and patented in 1956. It is a batch process that takes place in a reactor. This reactor may be called a Siemens dome reactor, reduction reactor, or a chemical vapor deposition reactor. The basic reactor design is a bell jar with three starter polysilicon rods, also called filaments. These filaments are approximately 7-8 mm size and are placed into an inverted U shape. Some companies have their own proprietary reactor design. Others purchase reactor technology from companies such as GT Solar. Reactors can be built to have more capacity, but this requires extensive engineering and design to ensure that there is uniform performance across the entire reactor surface. Some points to consider on choosing between multiple reactors or one larger reactor include:

- Turnaround time due to the batch nature of the process
- Growth rates are nonlinear across the length of a run (reach a point of diminishing return in the process)
- Equipment failure consequences on operability
- Purity levels

Filaments are electrically heated to 1832-2012°F (1,000-1,100°C) and voltage and current are adjusted throughout the batch. This process is highly energy intensive. The pressure of the reactor is approximately 85-270 psig (5.9-18.6 barg). Pure TCS is blended with a carrier gas, typically hydrogen, to form the gas phase feedstock to the polysilicon reactors. Mole concentrations of TCS in the carrier gas are typically 5-20% with exceptions to 50%. During the start of the batch, hydrogen is recycled through the reactor. Once the desired temperature is reached, TCS is mixed with hydrogen at a varying ratio and fed to the reactor. A gas distribution system, essentially a series of nozzles, is designed to produce uniform polysilicon deposition across the diameter and throughout the length of the rod. About 22 pounds (10 kg) of trichlorosilane is required to produce 2.2 pounds (1 kg) of

polysilicon. The exhaust gases must be recycled for the process to be cost effective.

The reactor is kept cold during the vapor deposition process. It is double walled and uses a water jacket for cooling. The filaments are the only items heated so that the reaction only takes place on the filaments themselves. Newly formed polysilicon therefore deposits directly on the filaments. The amount of time filaments are in the chemical vapor deposition process is proprietary to the polysilicon manufacturer, but one batch lasts approximately three to seven days with a twenty-four hour turnaround time. The growth rate of the filament is approximately one mm/h. The final filament diameter is approximately 200 mm with a filament length of greater than two mm and eight to sixteen filaments per reactor. The economic effects of an unplanned shutdown of a reactor are market dependent but can range from US\$60,000 to US\$100,000 per run of the reactor.

Recovery

The chemical vapor deposition reactor has low conversion efficiency, about 10-20%. Thus, STC is recovered and recycled. STC separation and conversion is a complex process involving distillation columns, cryogenics, and pressure swing adsorption. STC converters are chemical vapor deposition reactors with platinum filaments. This recovery process enables plants to recycle the silicon tetrachloride and eliminates byproducts that are difficult to handle. The hydrogen that is produced in the chemical vapor deposition reaction is purified through a pressure swing adsorption process, then compressed and returned to the process.

Supporting the whole plant are the offsite and utilities. This includes HCl synthesis and storage, either cryogenic or aqueous storage; exhaust gas recovery system; and utilities. There is a caustic scrubber for vent gas treatment that needs to handle 0-100% turndown. Also present is an emergency gas discharge tank of caustic with a mini scrubber on top. All drains in the plant must be sealed for safety reasons. All chlorides must be precipitated out before discharge of wastewater. On the utility side, the cooling water is the most critical process for plant safety. It is used to cool reactors and quench exhaust gases. These types of polysilicon plants are large consumers of electricity. Every reactor has its own electrical control equipment, transformers, and rectifiers.

The final processing step is packaging, which is a manual process. The finished polysilicon filaments

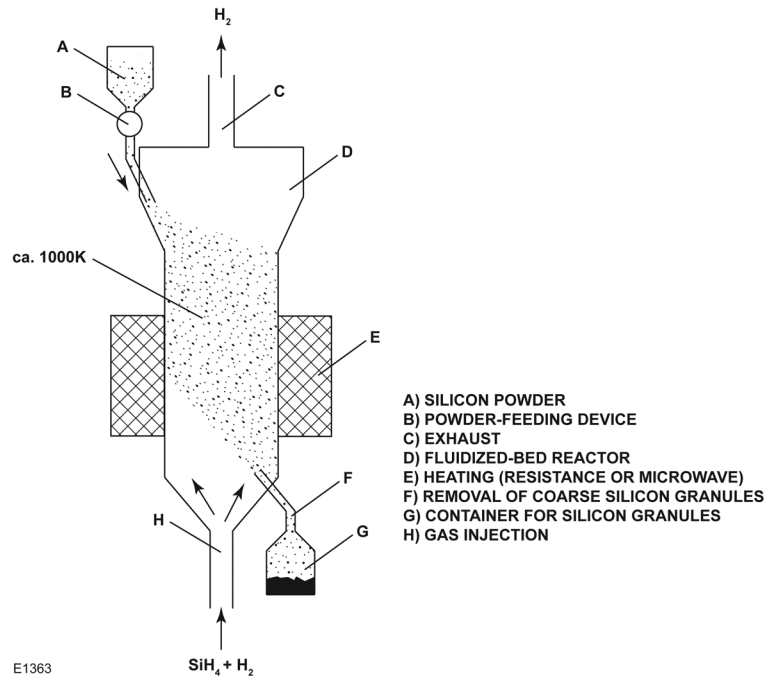

Figure 2-5. Chemical Vapor Deposition of Granular Silicon

are taken to a clean room where they are broken up into cut rod, chunk, chip, or fines to meet size requirements per customer specifications.

III. Fluidized Bed Reactor:

The fluidized bed reactor process is a closed loop, continuous reaction process that is becoming more common in polysilicon production. It is typically used to produce solar grade polysilicon. Polysilicon is produced in granular pellet form. Main benefits of this process over the Siemens process are that the fluidized bed reactor plants are typically smaller for the equivalent throughput, use much less energy, and polysilicon beads can be harvested continuously without having to shutdown the reactor. Less energy is required because the heat transfer is much more efficient, as the gases are heated going into the reactor. According to REC Silicon, this process will reduce energy consumption in the silane to polysilicon step by 80-90% from the Siemens process. The general process is trichlorosilane or silane production, polysilicon deposition in the fluidized bed reactor, and recovery/utilities.

Fine metallurgical grade silicon powder, granules of about 100 μm diameter, is heated to 1340°F (727°C). This silicon powder is let in through an opening at the top of the reactor and fluidized by the upflowing silane or TCS gas. The silane decomposes into silicon and hydrogen on the hot silicon particles. The silicon particles grow and when large enough, approximately one mm diameter, they fall to the bottom of the reactor where they are removed. There is some unwanted deposition of silicon on the hot walls of the reactor. A newer version of this process avoids this issue due to choice in reactor wall material.

IV. Critical Valve Applications and Special Considerations:

While most valves used for polysilicon production could be considered standard valve configurations (Vee-ball, easy-e, and GX valves), several applications are critical to the process and special considerations must be taken into account when selecting these valves, such as cleaning and process fluid containment. It can be said, though, that around the reactors, no one valve is more critical than another. However, there are some critical applications in the cooling water, vent gas, and recovery sections that have the potential to

shutdown the entire process and expose the plant to significant safety risks.

Critical Control Valve Applications

In the TCS purification section, there are several purification steps involving distillation columns. Distillation columns are found in various chemical processes and have the same basic setup. The objective is to separate a feed stream into light-component and heavy-component product streams. It relies on the relative volatility between the components that make up the feed stream. High volatility (lighter) components boil at a lower temperature than low volatility (heavier) components. Therefore, when heat is added to the column through a bottom reboiler, lighter materials are vaporized and rise to the top of the column. Overhead vapors are cooled until they condense and become a liquid again.

Efficiency of distillation depends upon the amount of contact between the vapor rising and the liquid falling down the column. Therefore, some of the overhead liquid product is sent back, or refluxed, to the top of the column. Increasing reflux will improve the purity of the overhead product; however, it also requires more heat from the reboiler to re-vaporize the lighter components in the reflux stream. Operation of a distillation column is a balancing act between product purity and energy usage. If the amount of vapor and liquid traveling through the column becomes too great, the column can “flood”. Too much reflux, too much reboil heat resulting in too much vapor, or both can cause flooding. When flooding occurs, efficiency of the distillation column is dramatically reduced with corresponding drops in product purities.

Figure 2-7 shows the general schematic of a distillation column. The valves associated with this are the feed, reflux, bottom product, overhead product, pressure control, and reboil valves.

Feed valves are typically used as flow or level control loops. An upstream unit or process often controls the feed valve. Unstable feed flow will make the distillation column difficult to control. A problem valve will often cause feed flow to oscillate. As a result, the column will alternate between too little and too much reboil heat. Depending upon the size and number of trays in the column, the effect of a swing in feed will take anywhere from several minutes to more than an hour to reach the ends of the column. Sometimes, reboil and reflux control will amplify the swings. As a result, meeting product purity targets becomes

more difficult. Operations personnel will normally respond by over-purifying the products, wasting energy to compensate for the problematic feed control valve.

The reflux valve is typically either a flow or column temperature control loop. It is used to adjust the purity of the overhead product. The higher the reflux rate, the more pure the overhead product will become. However, raising the reflux rate requires more reboil heat and will eventually flood the tower. A poorly operating reflux valve has the same effects as a bad feed valve. Product purities will oscillate and the column will be difficult to control. This ultimately affects the efficiency of the column.

The bottom product valve is used to control the level in the bottom of the column. Poor control of this valve can cause the level to change quickly and dramatically. Issues with this valve reduce efficiency or at worst, cause flooding in the column. The overhead product valve is used to control the level in the overhead receiver. It can also cause the level to change quickly and dramatically in the column. Problems with this application can reduce efficiency.

Pressure control valves provide the back pressure to the column. This is critical to controlling the stability of the tower. Stable pressure is required to ensure that temperature changes reflect composition changes and not pressure changes. With too small of a valve, the pressure response will be sluggish. Too large of a valve and small valve movement will cause a large pressure swing. Oscillating column pressure and difficult control result with either over- or under-sizing the valve.

The reboil valve controls the amount of heat put into the column by the reboiler. In many cases, steam is used as a heat source. The service is very clean and fugitive emissions are not a concern. Steam valves are usually very reliable; however, a problematic valve will make the column difficult to control precisely. This is especially true if the column feed is subject to frequent changes. Not all reboilers use steam though. Some use other high temperature process streams.

Regardless of distillation column application, the control valve solution needs to provide accurate and reliable control. Valves can affect column efficiency, stability, column energy usage, flooding, etc. An easy-e valve or GX valve is recommended and are typically CF8M constructions. A FIELDVUE digital valve controller should be utilized to achieve tight control. Diagnostics are key in these applications for preventative

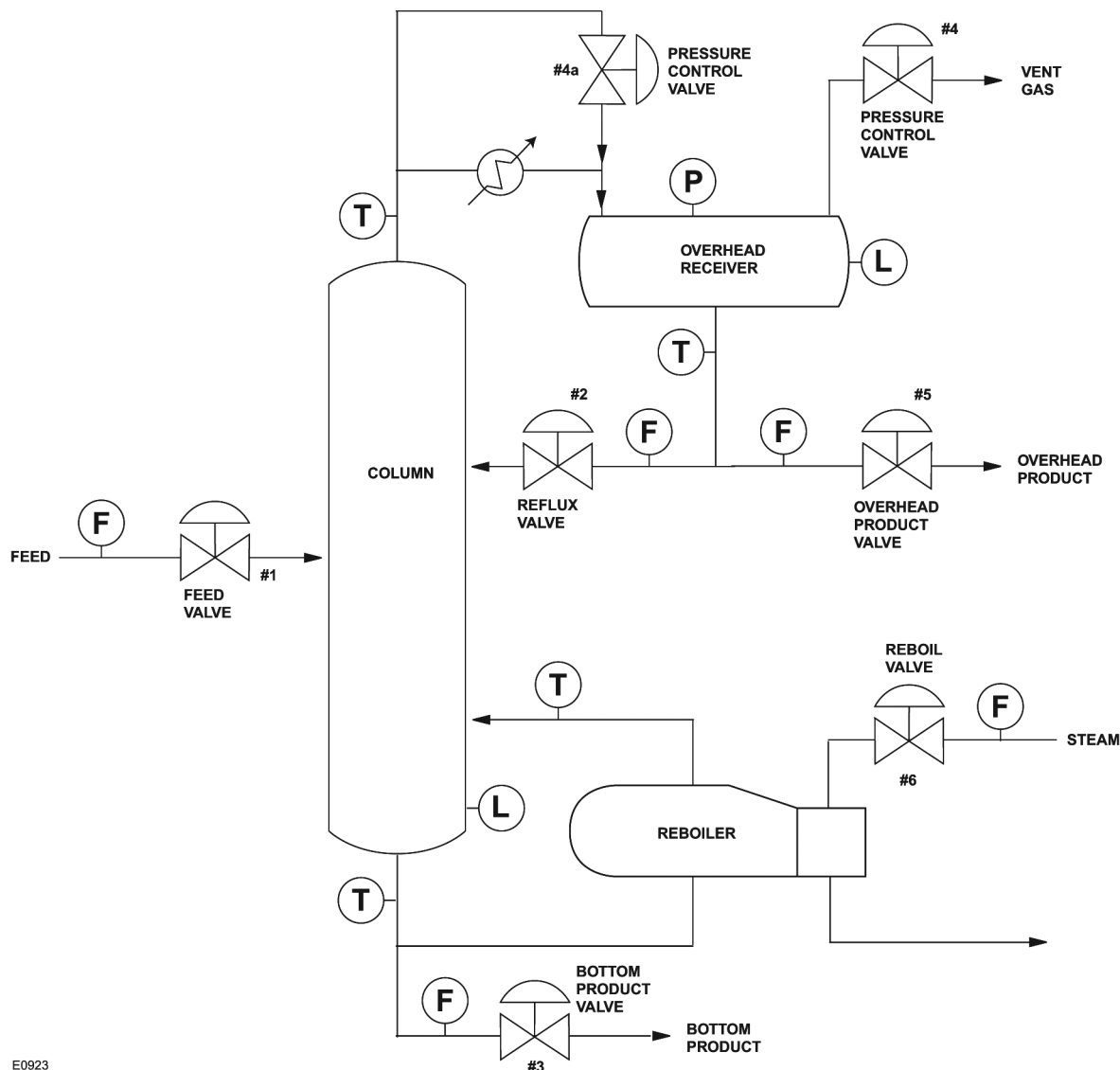

E0923

Figure 2-7. Schematic of a Basic Distillation Column

maintenance since distillation columns have long periods between shutdowns.

For vapor deposition applications, such as the feed valves to either the Siemens reactor or to the fluidized bed reactor and the vent valves on the Siemens reactor, tight control is necessary. Feed valves are critical in controlling the vapor deposition rate of producing polysilicon. Due to the critical nature of these valves, online diagnostics should be used to maintain performance and to perform predictive maintenance. In the Siemens reactor, envelope size is an important consideration as there is not always ample room around the reactor to fit the valves. The GX valve is a good fit as one of the design criteria was to

reduce the overall envelope size. Due to the high temperature of the reactor, remote mounting of the FIELDVUE digital valve controller may also be used.

For the vapor deposition reactor, cooling water is another critical application. If for any reason, cooling water is lost to a chemical vapor deposition reactor, even if electricity and gas supplies are isolated immediately, the reactor vessel will get so hot that it is likely to fail and potentially melt. It is important to employ predictive maintenance on all cooling water applications so that maintenance can be scheduled ahead of time to avoid control valve failures during operation.

PSA BASIC FLOW SCHEME

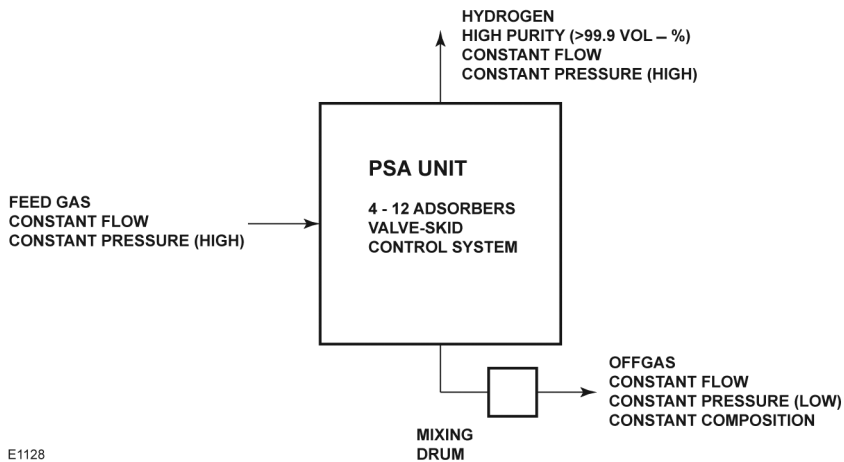

Figure 2-9. PSA Basic Flow Scheme



V6787

Figure 2-8. GX with DVC2000

In the recovery section, there are critical valve applications surrounding the hydrogen purification

and compression. Hydrogen purification is done through pressure swing adsorption (PSA). Control valves used in PSA applications are in a very high cycle service, seeing 100,000 to 250,000 cycles per year. Valves and actuators are expected to stroke once every three minutes. Stroking speeds are required to be fast and controlled. Uncontrolled opening can cause pressure/flow spikes. Depending upon the type and size of a PSA skid, the amount and type of control valves will vary. PSA skids can use globe and/or rotary valves. Control valve shutoff is a major concern because it affects PSA unit efficiency. Bi-directional flow conditions also exist. If valve leakage causes contamination from one PSA bed to another, industrial gas purity can be compromised.

A GX valve is the recommended globe valve solution for PSA service. It can handle stroking speeds up to 1.5 - 2 seconds. Class VI shutoff is necessary and bi-directional shutoff is standard in this construction. Certified emission control packing is standard to reduce potential hydrogen leakage. The recommended high performance butterfly valve construction requires the use of a pressure assisted UHMWPE seal. PTFE lined PEEK bearings that can withstand long cycle life requirements are used. Live loaded PTFE ENVIRO-SEAL packing is available to reduce hydrogen leakage.

These constructions have undergone extensive testing within the flow lab in Marshalltown, Iowa, United States to ensure that they meet the demands of PSA service. PSA testing is used to verify the life cycle of Fisher digital valves. PSA testing was designed and set up with input from

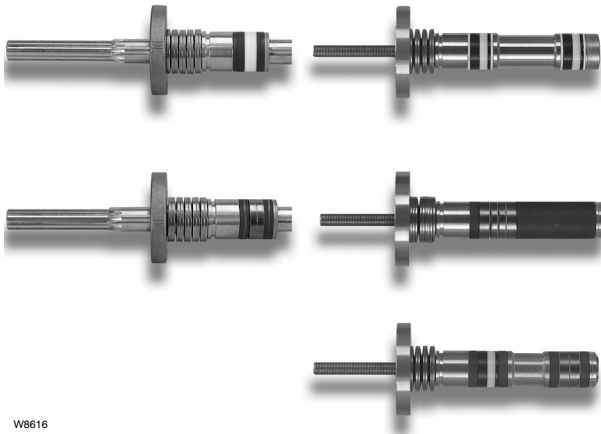

W8616

Figure 2-10. ENVIRO-SEAL Packing Systems

major PSA licensors to represent the PSA process as accurately as possible. Both the GX and butterfly valve solution have undergone rigorous testing to prove they can meet the high cycle demands of this service.

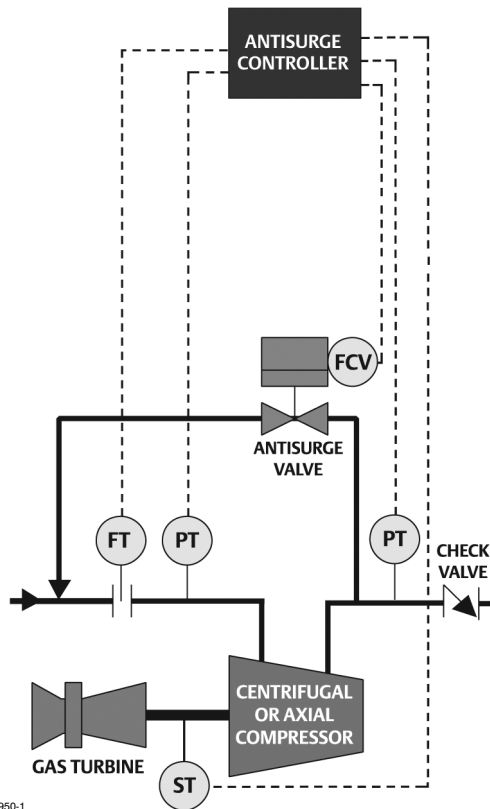

W8950-1

Figure 2-11. Antisurge Control System

Hydrogen also needs to go through a compressor before it is recycled back to the process. Typically, a reciprocating compressor is used for polysilicon plants. An antisurge control system is design to protect the compressor as it is an expensive piece of equipment and critical to the process. The system is designed to provide a faster response than adjusting the turbine speed to control the onset of surge. The controller looks at multiple variables to prevent the onset of surge. It requires fast, accurate response in order to prevent surge conditions. Characteristics of a surge condition are fast flow reversal (measured in milliseconds), excessive compressor vibration, increase in flowing media temperature, noise, and it may cause the compressor to “trip”. Consequences of surge situations are substantial and may include shortened compressor life, loss of efficiency, reduced compressor output, and mechanical damage to seals, bearings, impellers, etc.

Antisurge control valves present many various challenges. The key challenge is ensuring valve reliability. There is an extended period between maintenance cycles and it is important to ensure a reliable control valve assembly solution. The antisurge valve is the main piece of equipment that protects the compressor from damage caused by a surge. When these valves are called upon to move, they are required to stroke very quickly, typically in the open direction only. This can necessitate oversized actuator connections and the use of volume booster(s) and quick exhaust valve(s). Improper selection of these accessories will result in poor valve performance and tuning difficulties. During a surge event, pressure drop and flow rate experienced by the valve can be high, causing excessive levels of noise. This must be considered in valve selection, although noise control throughout the entire range of valve travel may not be required. This valve may also be required to throttle intermittently from 0 to 100% open. These cases require the valve to have fast, accurate control for incremental step sizes. Any delays can cause a surge to occur. The antisurge valve must be able to pass the highest possible output capacity of the compressor. Application of a multiplying factor to the compressor capacity figure is common and may lead to selection of an oversized valve. Valves with too much capacity often have controllability issues and can cause unstable operation.

Emerson has developed an optimized antisurge package to meet the challenging demands of this application. Some highlights of this package will be discussed, but for more information, please see the brochure titled “Fisher Optimized Antisurge Control Valves”. These valves use a spoked plug

versus the traditional balanced plug. With the traditional plug, when the valve is asked to move very quickly, there is not enough area in the balance holes to keep the plug in a balanced state; therefore, creating a differential pressure situation between the top and the bottom of the plug. This differential pressure case can lead to plug instability. The spoked plug has large balance areas so that this does not occur. For surge events where noise is a concern, a Fisher valve with a Whisper Trim III or WhisperFlo trim is recommended.

Emerson has the engineering capability to characterize these trims in order to meet the specific application needs and tailor a solution towards them. When the valve assembly is called upon to move quickly, mechanical air cushions have been added to the actuator cylinder to provide controlled deceleration to help protect actuator and valve components for longer travel applications.

The Fisher optimized antisurge package also includes a FIELDVUE digital valve controller with the optimized digital valve (ODV) tier. Features within this tier and in AMS ValveLink software meet the needs of the application. For example, factory expertise is not required to tune the Fisher optimized antisurge valve. A technician can simply use ValveLink software's performance tuner or the stabilize/optimize feature with real time graphics. Configuration and tuning can also be performed remotely by operators as process requirements change. This feature gives plant operators and technicians the capability to tune this assembly in the field. The lead-lag filter in the ODV tier can be used to improve the response to small amplitude steps by overdriving the set point. Asymmetric adjustments allow the response to be set independently in the open and closing directions. Integrated, real time graphics allow adjustments to be done remotely as well. Also, diagnostics can be collected, viewed, and analyzed using ValveLink software to look at items such as packing friction, air path leakage, actuator spring rate, and bench set. Partial stroke tests can also be performed to check the health of the valve and ensure the antisurge valve is going to move when it is requested to.

The conversion of STC in the recovery process uses distillation columns. These applications are the same as discussed in the TCS purification. See the above text for more details.

The final step in the Siemens process is the manual breaking and packaging of the polysilicon

inside a clean room. This requires an industrial heating, ventilating, and air conditioning (HVAC) system to meet the air cleanliness requirements of the clean room. Industrial HVAC means using industrial grade control equipment to control the environment to support the process, not human comfort. These facilities should be designed to provide the necessary protection to minimize the risk of contamination and to ensure that appropriate air quality (temperature, humidity and particulates) is maintained, especially in areas where product is exposed to the environment. This is critical to maintaining the purity of the product that is such a concern throughout the entire process. The HVAC system needs to provide good performance, be reliable, and be low maintenance. While the valve applications are generally simple, it is important to have an accurate (<1% device) and reliable valve assembly to ensure overall system performance. Generally, the Baumann 24000 series works well in these applications. There are a variety of valve sizes, materials, and trims available to meet each individual application. The small light weight design is ideal for installation in tight areas such as around air handling equipment, which is typically located in ceiling crawl spaces above the clean room. Also, adding a FIELDVUE DVC2000 reduces start up time by allowing for simple local push-button calibration, while adding remote diagnostic capability to monitor valve performance in difficult to access installations.

There are many toxic, lethal, and explosive fluids that need to be contained throughout the polysilicon process. Chlorine, HCl, TCS, STC, and hydrogen are flammable, corrosive, toxic, and explosive. Silane ignites spontaneously with air. HCl or TCS plus air gives hydrochloric acid, so systems containing these fluids need to be kept completely dry. Depending upon the process fluid, government regulations, and customer specifications, either ENVIRO-SEAL packing or ENVIRO-SEAL bellows will need to be used. ENVIRO-SEAL packing limits emissions while ENVIRO-SEAL bellows eliminates emissions.

Special Cleaning

Contamination is a major factor in the production of polysilicon because the end product needs to meet such stringent purity levels. Residual grease, oil, etc. in process equipment after maintenance, testing, or initial construction causes product quality issues and produces off-specification product. Phosphorous is a big contaminant and can ruin batches. Some greases that are approved for oxygen use are not acceptable in polysilicon



W9510

Figure 2-12. 24000 with DVC2000



W9343

Figure 2-13. GX with ENVIRO-SEAL Bellows

environments. The cleaning process required varies from one polysilicon producer to the next. Emerson has created and utilizes standard degreasing levels for Fisher control valves; Class A for non-oxygen fluids and Class AAA for oxygen applications. Typically, polysilicon projects have

required some form of Class A degreasing. This may be modified to specify a certain cleaner or a non-phosphate rinse at the end of the cleaning process. Emerson has also worked with polysilicon manufacturers to tailor a cleaning process to meet their specific needs.

Safety Instrumented Systems

Due to the nature of the process fluids involvement and the reactions taking place, safety is an important and critical part of the production process. Safety instrumented systems (SIS) are put in place to ensure protection against accidents such as toxic chemical releases, facility explosions, or fires. The SIS valve is present to take the process to a safe state when specified (dangerous) conditions are violated. Loops are evaluated by plants to determine what safety integrity level (SIL) level is needed for that safety application. Several Fisher products have been certified and are suitable for use in SIS applications. These products include the FIELDVUE DVC6000 SIS, GX, Vee-ball, HP, easy-e, 8580, A81, and the Control-Disk along with the respective actuators for the valves. Typically, safety valves operate in one static position and only move upon an emergency situation. Without mechanical movement for long periods of time, unreliability inherently increases. To ensure availability on demand, SIS valves must undergo regular testing. This includes not only full stroke tests, but also partial stroke tests that can be used to increase the time between full proof tests. The DVC6000 SIS can be utilized to perform partial stroke testing. It can move the valve between 1 and 30% from its original position. Partial stroke tests can be scheduled via the automatic test scheduler. If an emergency demand occurs, the response will override the testing. Using smart positioner technology with partial stroke testing provides for predictive maintenance through diagnostic information.

V. Conclusion:

As technical uses for polysilicon grow along with the demand for solar power, the polysilicon market will continue to expand. Reliability, safety, control, purity levels, and variability are all affected by the control valves used in the process. It is important to understand the polysilicon process in order to apply the proper control valve solution for various applications.

Fisher, easy-e, FIELDVUE, ENVIRO-SEAL, Whisper Trim, WhisperFlo, ValveLink, NotchFlo and Cavitrol are marks owned by one of the companies in the Emerson Process Management business division of Emerson Electric Co. Emerson Process Management, Emerson, and the Emerson logo are trademarks and service marks of Emerson Electric Co. All other marks are the property of their respective owners.

The contents of this publication are presented for informational purposes only, and while every effort has been made to ensure their accuracy, they are not to be construed as warranties or guarantees, express or implied, regarding the products or services described herein or their use or applicability. All sales are governed by our terms and conditions, which are available upon request. We reserve the right to modify or improve the designs or specifications of such products at any time without notice. Neither Emerson, Emerson Process Management, nor any of their affiliated entities assumes responsibility for the selection, use or maintenance of any product. Responsibility for proper selection, use, and maintenance of any product remains solely with the purchaser and end user.

Emerson Process Management

Marshalltown, Iowa 50158 USA

Sorocaba, 18087 Brazil

Chatham, Kent ME4 4QZ UK

Dubai, United Arab Emirates

Singapore 128461 Singapore

www.Fisher.com



EMERSON[™]
Process Management