

# Fisher® easy-e™ Control Valves

For easy application and unmatched performance



# Fisher easy-e Control Valves



## Fisher® easy-e® Control Valves

### For easy application and unmatched performance

**E**merson's Fisher® **easy-e**™ control valve is found in every industry where fluid flow must be controlled, providing users with improved process performance and reliability. Whether the application involves refining, oil and gas production, power generation, paper manufacturing or chemical processing, you will find the **easy-e** at work. Here are four reasons why:

**Easy To Choose** — With its single valve design platform, you can easily select the **easy-e** valve configuration that best meets your process requirements.

**Easy To Install** — A choice of body sizes and end connections plus body styles means there's an **easy-e** valve for most piping requirements.

**Easy To Maintain** — The **easy-e** valve's quick-change, cage-style trim reduces the maintenance challenge, which increases operating time and reduces operating expense.

**Easy To Own** — The **easy-e** valve gives you a high return on your control valve investment thanks to its long operating life and enhanced control performance.

#### **easy-e Control Valve**

*As a core component of Emerson's PlantWeb™ digital plant architecture, the Fisher easy-e control valve reduces process variability, allowing you to operate closer to production targets.*



**Easy to Operate:** Your choices for an **easy-e** operating system range from a FIELDVUE™ digital valve controller coupled with a spring-and-diaphragm actuator to a simple, manual hand-wheel operator. Designed for PlantWeb digital plant architecture, FIELDVUE instruments and AMS ValveLink™ software enable you to run your operation more efficiently, safely, and profitably by delivering new insights on valve health. The spring-and-diaphragm actuator is commonly specified because its reliability and wide range of sizes, travels, and thrusts make it ideal for general service applications. Piston actuators are often specified for high thrust and long travels.

## Money and Time-Saving Benefits



### Quick-Change Trim Means Fast Service

*The easy-e valve's quick-change, cage-style trim reduces the maintenance challenge, which increases operating time and reduces operating expense.*



### Incorporating the Fisher easy-e valve into your process can have significant money and time-saving benefits:

- **Reduce Downtime** - The rugged **easy-e** valve results from extensive flow testing and evaluation, yielding a robust control valve that is the industry standard for dependability and longevity.
- **Reduce Maintenance Costs** - The drop-in **easy-e** cage, valve plug and seat ring are designed to be removed from the top for quick inspection and easy service. This allows you to leave the valve body in line, resulting in greater savings in maintenance time and reduced downtime costs.
- **Gain Application Versatility** - Since trim parts are interchangeable across the **easy-e** line, you maximize your control options as you minimize your control valve investment.
- **Reduce Parts Inventory** - Because seat rings, cages, gaskets, stems, bonnets, packing seals and many other parts on the **easy-e** valve are interchangeable, trim inventory costs can be kept to a minimum, resulting in savings that go right to your bottom line.
- **Reduce Training Costs** - Because the **easy-e** valve adapts to a broad range of applications, engineering and maintenance training can focus on how to make the most of this flexible valve design. Rather than having to be familiar with a variety of control valve platforms, your staff can quickly apply the flexibility of the **easy-e** to many different applications within your operation.
- **Achieve Worldwide Consistency** - No matter where you obtain or use your **easy-e** valve, the dimensions and parts will be uniform, eliminating problems that arise from non-interchangeability.
- **Improve Total Cost of Ownership** - Quality Fisher construction provides long life with minimum service requirements. The standard flow cage, valve plug and seat ring are constructed of hardened stainless steel. Trim parts are precision manufactured to provide smooth operation for years to come.

In addition to providing top quality, expertly engineered valves, Emerson is committed to providing you with exceptional customer service. Emerson's application assistance, responsive replacement parts service, control valve repair, and training add even more value to the Fisher easy-e control valve.



**Setting the Standard For Performance**

*The easy-e globe valve has undergone rigorous and extensive testing and evaluation. Results from flow variability testing, hydrostatic pressure testing, capacity verification, metallurgical development and cycle life testing all lead to one conclusion – the easy-e globe valve meets or exceeds the demanding requirements established by the process control industry.*

## The Versatility and Simplicity of the easy-e Valve

No other valve offers the broad range application versatility of Emerson's Fisher **easy-e** globe valve. The **easy-e** control valve is available with a choice of trim styles and sizes that lets you specify just the right amount of control for your application. Your Emerson salesperson has the expertise to help you select the best combination to get the job done.

### Unmatched Capacity

Due to its proven cage-guided design, the **easy-e** delivers unmatched flow capacities. This allows you the freedom of applying the **easy-e** in a wide range of service conditions, maximizing your control options.

The standard valve stem packing in the **easy-e** valve is the PTFE V-ring. Suitable for in-body process temperatures to 232°C (450°F), PTFE packing minimizes friction and does not require lubrication. For higher temperature service, specify graphite packing.



### ENVIRO-SEAL™ Packing System

Packing selection is increasingly being driven by governmental regulations and our customers' concern for the environment. ENVIRO-SEAL™ is an advanced packing system that provides the measure of emission control security that you require.

Using a compact, live-loaded design and a variety of material options, the ENVIRO-SEAL packing system provides superior sealing performance for almost any application. The ENVIRO-SEAL system provides a constant load over the life of the packing material, greatly reducing the need for packing box adjustment and maintenance.

### Change Flow Characteristics

#### Without Changing the Valve Plug or Seat Ring

The flow cage within the **easy-e** valve with balanced trim not only guides the valve plug and retains the seat ring, it also determines the flow characteristic of the valve. With these cage options, the flow characteristic can be changed quickly with a minimum of downtime. Special cage configurations are also available to meet severe service demands caused by turbulent gas flow and cavitating liquid.

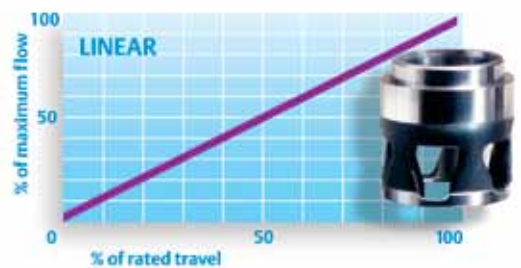

**Linear** — The flow capacity is directly proportional to the valve plug travel.

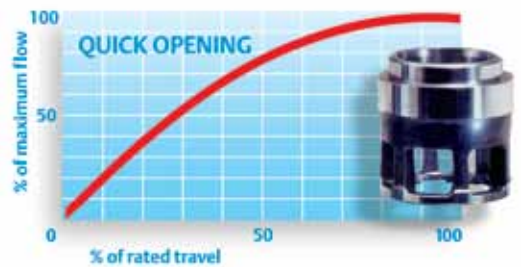

**Quick Opening** — The flow capacity increases sharply at low valve plug travels and more slowly as the valve travels to its maximum.

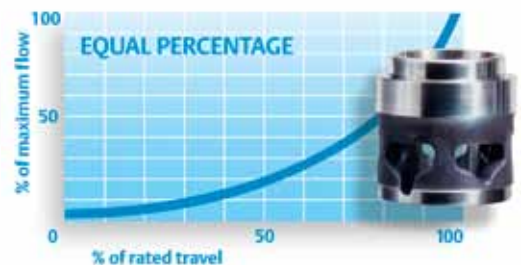

**Equal Percentage** — The flow capacity increases by the same percentage for each equal increment change in plug travel. This provides excellent rangeability, as well as control resolution at small increments of travel.

## CERTIFICATE

TÜV  
SAARLAND

TÜV Saarland e.V.  
Wir zertifizieren die Äquivalenz von Stängelabdichtung  
mit TA Luft-Packing

Type: Drawing Nr. 13 B 7183 / B and 12 B 6932 / A  
Type: Drawing Nr. 12 B 8529 / B and 12 B 6927 / A

EMERSON PROCESS MANAGEMENT  
Rue Paul Baudry  
B.P. 10  
F- 68701 Cerney Cedex

### Packing Certifications

**TÜV has certified the stem sealing capabilities of ENVIRO-SEAL PTFE and graphite packing systems for sliding-stem valves with TA Luft emission control requirements. Emission control packing compliance to FCI/ANSI 91-1 has been certified by Yarmouth Research and Technology.**

TÜV Saarland e.V.  
Dipl. Ing. J. Matten

## The Right Trim For the Job

There's a lineup of **easy-e** trim designs, in full or reduced port sizes, to help you match application requirements.

① **Post-Guided Trim** — This clean-cavity, post-guided design is excellent for general applications, as well as viscous, non-lubricating and other hard to handle process fluids. Shutoff capabilities include Class IV and V (metal seat), and Class VI (soft seat).

② **Balanced Trim** — The versatility of this general purpose, cage-guided trim design puts you in control of a variety of liquids and gases over a wide range of temperatures. Its balanced design reduces actuator thrust requirements for even greater economy in actuator sizing and selection.

The balanced trim design offers a choice of metal-to-metal or soft seating for Class II through Class VI shutoff capability.

③ **Low Flow Trims** — The precisely engineered MicroForm and MicroFlute trim options are ideal for reduced flow applications. These trim options not only meet your small capacity needs, but also allow the use of a standard **easy-e** valve, which helps keep parts inventory at a minimum.

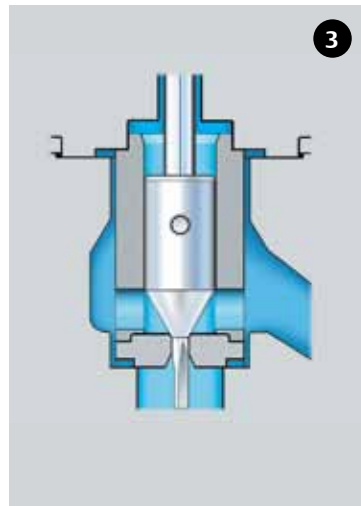
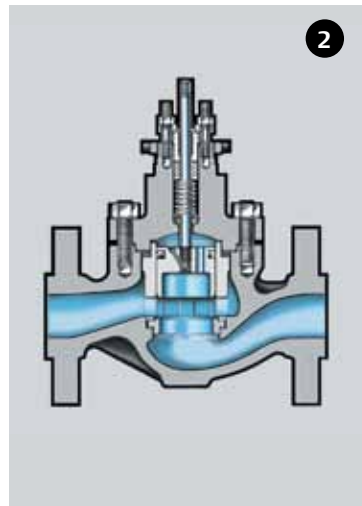
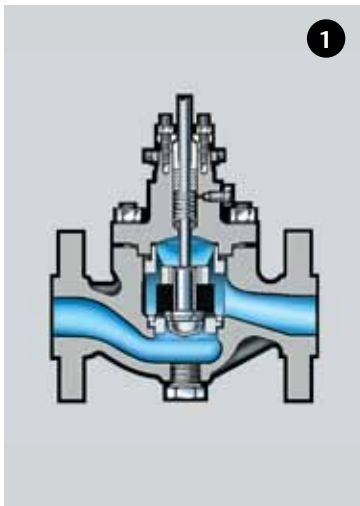

## Severe Service Trims For Your Toughest Applications

Highly engineered trims are available to reduce aerodynamic noise in gaseous service and eliminate cavitation damage in liquid service.

④ **Cavitrol™ III Trim** — Helps prevent cavitation and resultant damage at high pressure drops. Cavitrol III trim also reduces or eliminates cavitation noise.

⑤ **WhisperFlo™ Trim** — An industry leader, this multi-path, multi-stage trim reduces aerodynamic noise by as much as 40 dBA. The patented WhisperFlo trim delivers a break-through combination of noise abatement performance and high capacity.



4



## easy-e Valve Selection Guide

### Choose the Body Style to Fit the Line

A choice of **easy-e** valve body styles lets you meet a variety of application and pipeline requirements. Bodies with expanded ends or extra long travel give added flexibility in reducing noise regeneration due to high outlet velocities.

Fisher **easy-e** valve sizes range from 1/2 inch up through 24 inch and DN 15 through DN 600. Pressure ratings cover ANSI Class 150 through Class 600 and PN 10 through PN 100. End connections include flanged, screwed and welded.

### Availability/Overview

Trim Type	Trim Designator	Standard Shutoff
Post-Guided General Service	Z	Class IV (metal) and VI (soft) per ANSI/FCI 70-2
Balanced General Service	D	Class II per ANSI/FCI 70-2
Balanced Tight Shutoff	T	Classes IV, V, and VI per ANSI/FCI 70-2

Body Style	Design Designator	Body Size	Body Rating ASME/European	Trim Style
Standard Globe	E	1/2 to 8-inch	Class 150-600/PN 10-100	Balanced, Post-Guided
Expanded Flange	EW	4 x 2-inch to 24 x 20-inch	Class 150-600/PN 10-100	Balanced, Unbalanced
Angle	EA	1 to 6-inch	Class 150-600/PN 10-100	Balanced, Unbalanced
Large Globe w/Long Travel	EU	12,16,20-inch	Class 150-600/PN 10-100	Balanced

Capacity Comparisons (CV)				
Size	Post-Guided Trim		Balanced Trim	
	Quick Opening	Equal Percentage	Quick Opening	Equal Percentage
1"	16.9	13.2	22.1	17.2
1 1/2"	34.2	28.1	44	35.8
2"	58.6	53.8	77.6	59.7
3"	129	114	161	136
4"	223	190	251	224
6"			460	394
8"			863	818



**Standard globe style**



**Angle style**



**Expanded end style**

## You Get More Than a Piece of Hardware

In the battle for performance and production, you need every advantage you can get. From application expertise to training to quick replacement parts to valve repairs, you can always count on Emerson for quality, service and expertise.



### Expert Application Assistance From the Application Experts

The next time you need to specify a control valve for your system, whether for general service or severe, consider the **easy-e** valve. Contact the Emerson sales office in your area. If you don't know who they are, visit our Web site at [www.EmersonProcess.com/Fisher](http://www.EmersonProcess.com/Fisher) and click on Sales Contacts. Highly skilled and experienced applications personnel are ready to help you take advantage of the many benefits of the **easy-e** valve.

### Fisher Control Valve Training Puts You In The Know

Emerson offers comprehensive customer training and education programs that cover a wide range of process topics. The programs consist of structured courses that are geared to real-world situations. Customer training is provided at our educational facilities located near you. In addition to standard programs, tailored courses designed for the specific needs of an organization can be conducted on-site. Prepackaged Fisher training courses are available in video format, making self-training convenient and cost-effective. [www.EmersonProcess.com/education](http://www.EmersonProcess.com/education)

### FAST Service Keeps You Up And Running

FAST parts distribution offers express delivery of replacement parts. Now you can fine-tune your plant's maintenance inventory with the knowledge that control valve needs for plant turnarounds, scheduled maintenance programs, as well as unplanned valve repair can be met quickly with genuine Fisher parts and control valves.



### Fisher Control Valve Repair Is at Your Service

With facilities at strategic locations around the world, Emerson's Instrument & Valve Services gives you fast turnaround of emergency and routine valve repairs. You'll get factory-authorized repair using genuine Fisher parts, plus each total valve repair receives a one-year warranty. All Instrument & Valve Services locations have direct access to the extensive serial number database so your repairable Fisher valves are rebuilt to meet original factory specifications.

[www.EmersonProcess.com/IVS](http://www.EmersonProcess.com/IVS)





This mark indicates a core component of Emerson's PlantWeb™ digital plant architecture.

© Fisher Controls International LLC 2007, 2011 All Rights Reserved.

Fisher, easy-e, PlantWeb, FIELDVUE, AMS, ValveLink, ENVIRO-SEAL, Cavitol, WhisperFlo, and FisherFAST are marks owned by one of the companies in the Emerson Process Management business division of Emerson Electric Co. Emerson Process Management, Emerson, and the Emerson logo are trademarks and service marks of Emerson Electric Co. All other marks are the property of their respective owners.

The contents of this publication are presented for informational purposes only, and while every effort has been made to ensure their accuracy they are not to be construed as warranties or guarantees, express or implied, regarding the products or services described herein or their use or applicability. All sales are governed by our terms and conditions, which are available upon request. We reserve the right to modify or improve the designs or specifications of such products at any time without notice. Neither Emerson, Emerson Process Management, nor any of their affiliated entities assumes responsibility for the selection, use, or maintenance of any product. Responsibility for proper selection, use, and maintenance of any product remains solely with the purchaser and end user.

**Emerson Process Management**  
 Marshalltown, Iowa 50158 USA  
 Sorocaba, 18087 Brazil  
 Chatham, Kent ME4 4QZ UK  
 Dubai, United Arab Emirates  
 Singapore 128461 Singapore  
[www.EmersonProcess.com/Fisher](http://www.EmersonProcess.com/Fisher)

