

Fisher® Cavitation Control for Dirty Service



FISHER®
Severe Service

EMERSON™
Process Management

Fisher® Cavitation Control for Dirty Service

Severe flow conditions.

Cavitation with entrained particulate create a challenging, severe condition for a control valve. If the control valve does not perform as required, your facility could experience unscheduled downtime. Entrained particulate can shorten control valve life by plugging the cage and causing material erosion of the plug, cage, and seat. Cavitation leads to unacceptable noise and vibration. Damage to control valve trim also occurs.

Introducing four Fisher® cavitation-control technologies ideal for dirty service applications: the NotchFlo™ DST control valve, Dirty Service Trim (DST), Dirty Service Trim for outgassing (DST-G), and 461 angle valve. These technologies allow entrained particulate to pass, while resisting cavitation damage in severe liquid flow conditions.

In addition, Fisher Cavitol™ III trim with improved sealing technologies is available for power applications where plug tip erosion and seal wear are issues.

No force-fit solutions. The right technology for your need.

Working at your side, your local Emerson Process Management application expert can help you select and implement the best Fisher technology for your specific application. There are no force-fit solutions. Our expert recommendations are based on your specific challenges and our application experience. The broad Fisher product line of dirty service technologies allows you to choose the right technology.

Typical dirty service, cavitating applications.

Fisher technologies are proven in severe flow conditions such as catalyst fines in refineries, magnetite in power plants, and sand in oil production. Additional applications include:

- Oil and Gas Production - Water injection pump recirculation. Produced/wastewater injection well control. Separator letdown. Chemical injection pump bypass.
- Refining - Contactor letdown. Rich and lean amine pump spillback. Pump spillback/recirculation. Various high- and low-pressure separator letdown.
- Power/Cogeneration - Boiler feed pump recirculation. Desuperheater spray water control. Feedwater start-up regulator. Superheater bypass.

Whatever your need, wherever you are.

Wherever your facility is located, Fisher control valves are fully supported. Emerson has the most extensive global network of field specialists of any supplier. For additional information on Fisher cavitation control for dirty service, go to www.FisherSevereService.com or contact an Emerson Process Management sales office.

NotchFlo™ DST Control Valve

uses a series of flow restrictions and expansions to control the pressure drop of the fluid. The notched plug allows up to 12 mm (½-inch) particulate to flow through the trim without plugging.

- 3, 4, or 6-stage trim
- ASME Class 150 - 1500 globe body
- ASME Class 150 - 2500 angle body
- NPS 1 - 8
- Flow-up design only
- 290 bar (4200 psi) pressure drop limit
- ANSI/FCI Class V shutoff
- Ability to pass 12 mm (½-inch) particulate, depending on valve size



Dirty Service Trim (DST)

uses a combined axial and radial flow path that features large openings allowing particulate up to 19 mm (¾-inch) to pass through the valve. Can be used in easy-e™, EH, EHA, EW, HP, and HPA valves.

- 2, 3, 4, 5 or 6-stage trim
- Globe or angle body
- ASME Class 150 - 2500
- NPS 1 - 24
- Flow-down or flow-up design
- 290 bar (4200 psi) pressure drop limit

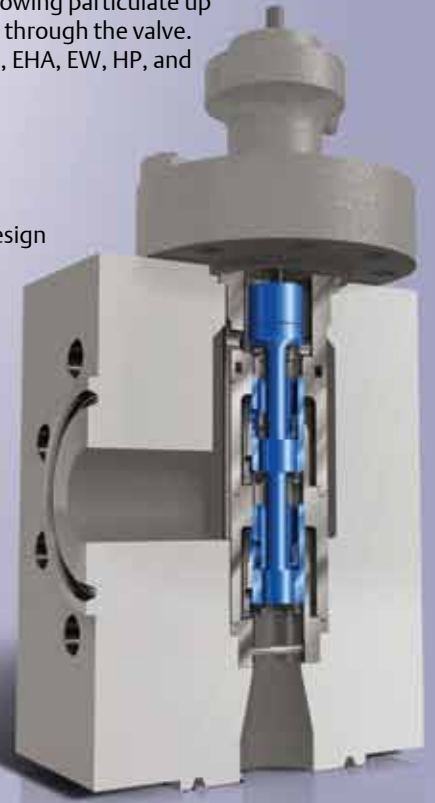

Dirty Service Trim for Outgassing (DST-G)

is a multi-stage control valve trim design. It is used in services where the fluid has dissolved gases that are released from solution due to a reduction in pressure. The fluid may also contain entrained particulate.

- Multi-stage trim
- Angle body
- ASME Class 150 - 2500
- NPS 1 - 12
- Flow-down design
- 175 bar (2500 psi) pressure drop limit
- ANSI/FCI Class V shutoff



461 Sweep-Flo Angle Valve

is self cleaning with an expanded outlet. It is typically used in the chemical and hydrocarbon industries where cavitation control is required for residual oils that experience coking, have high particulate content and viscosity, and may outgas.

- Sweep-Flo angle body
- ASME Class 150 - 2500
- NPS 2x3, 3x4, 4x6, and 6x8
- Flow-down design
- ANSI/FCI Class V shutoff



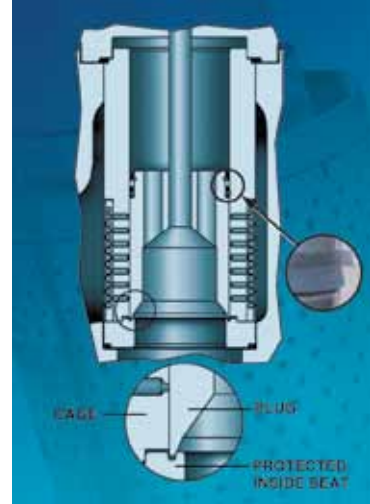
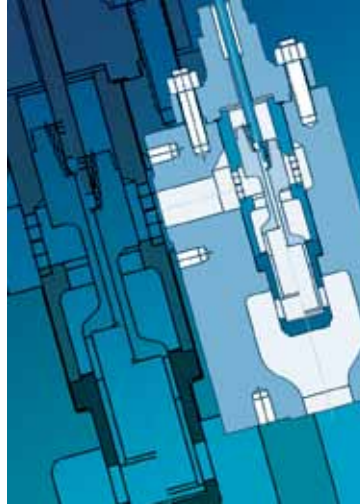

© Fisher Controls International LLC 2010, 2011 All Rights Reserved.

Fisher, NotchFlo, Cavitrol, and easy-e are marks owned by one of the companies in the Emerson Process Management business division of Emerson Electric Co. Emerson Process Management, Emerson, and the Emerson logo are trademarks and service marks of Emerson Electric Co. All other marks are the property of their respective owners.

The contents of this publication are presented for informational purposes only, and while every effort has been made to ensure their accuracy they are not to be construed as warranties or guarantees, express or implied, regarding the products or services described herein or their use or applicability. All sales are governed by our terms and conditions, which are available upon request. We reserve the right to modify or improve the designs or specifications of such products at any time without notice. Neither Emerson, Emerson Process Management, nor any of their affiliated entities assumes responsibility for the selection, use, or maintenance of any product. Responsibility for proper selection, use, and maintenance of any product remains solely with the purchaser and end-user.

Emerson Process Management
Marshalltown, Iowa 50158 USA
Sorocaba, 18087 Brazil
Chatham, Kent ME4 4QZ UK
Dubai, United Arab Emirates
Singapore 128461 Singapore
www.EmersonProcess.com/Fisher

