

PRESSURE REGULATORS

Type Cronos

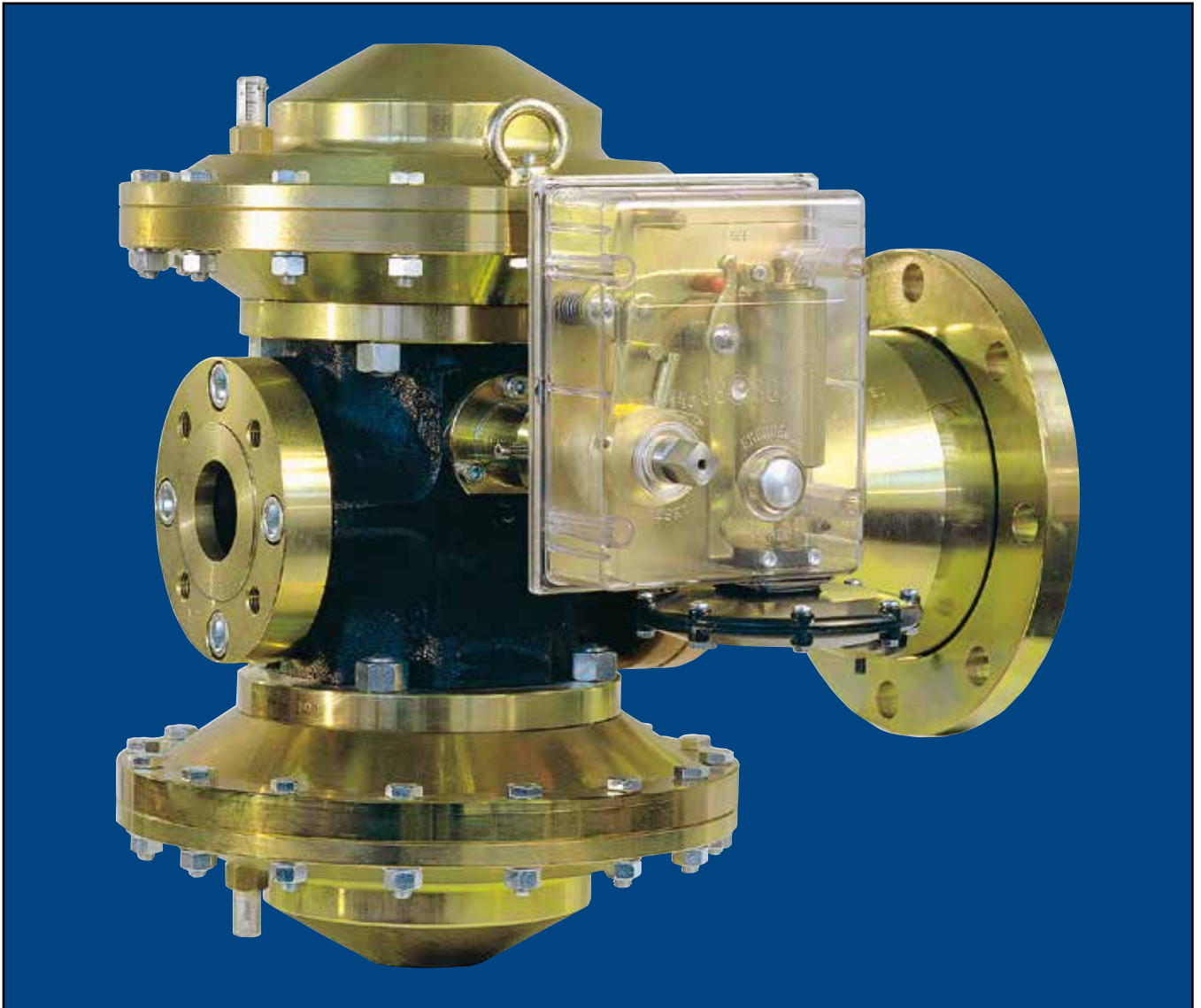

Cronos Regulators

Pressure Regulators

This series of “Top-Entry” appliances was designed to meet a wide range of applications, offering easy maintenance combined with compact size.

To achieve this, we introduced a new modularity concept which, combined with our experience and TARTARINI technologies developed in axial flow regulators, has enabled us to build a wide range of versions to the same design philosophy.

These are, in brief, the features of the project:

- **MODULARITY**

Modularity is ensured by a central cross-shaped body, which is the system’s key component, enabling either horizontal or 90° gas flow.

The other components are assembled to it (flange, regulator head, monitor head, shut-off, and silencers).

- **COUNTERBALANCED SHUTTER**

Use of a special counter-balanced shutter of very simple design, makes CRONOS highly reliable, easy to maintain, in the more complex configurations too (Shut-off, Monitor, Regulator, Silencer).

Versatile design can clearly be seen in the CCBS right-angled model, which Tartarini uses to make highly compact reduction units.



Configurations



C Regulator



CB Regulator + Shut-off



CC Regulator + Monitor



CCB Regulator + Monitor + Shut-off

Configurations	ID-ABBREVIATIONS					
	Standard	Horizontal flow		90° flow		
		Silenced		Standard	Silenced	
		SR	SRS		SR	SRS
Regulator	C	C-SR	C-SRS	-	-	-
Regulator + Shut-off	CB	CB-SR	CB-SRS	CBS	CBS-SR	CBS-SRS
Regulator + Monitor	CC	CC-SR	CC-SRS	CCS	CCS-SR	CCS-SRS
Regulator + Monitor + Shut-off	CCB	CCB-SR	CCB-SRS	CCBS	CCBS-SR	CCBS-SRS

N.B.: SRS silenced solutions have a widened output flange.
Also available: version with widened output, but without a built-in silencer.

Examples of Descriptions:

DN 25 ANSI 150 horizontal flow regulator with SRS silencer:

C/025x100 ANSI 150 SRS

DN 25 ANSI 150 horizontal flow regulator with widened output:

C/025x100 ANSI 150

Cronos Regulators

Operation

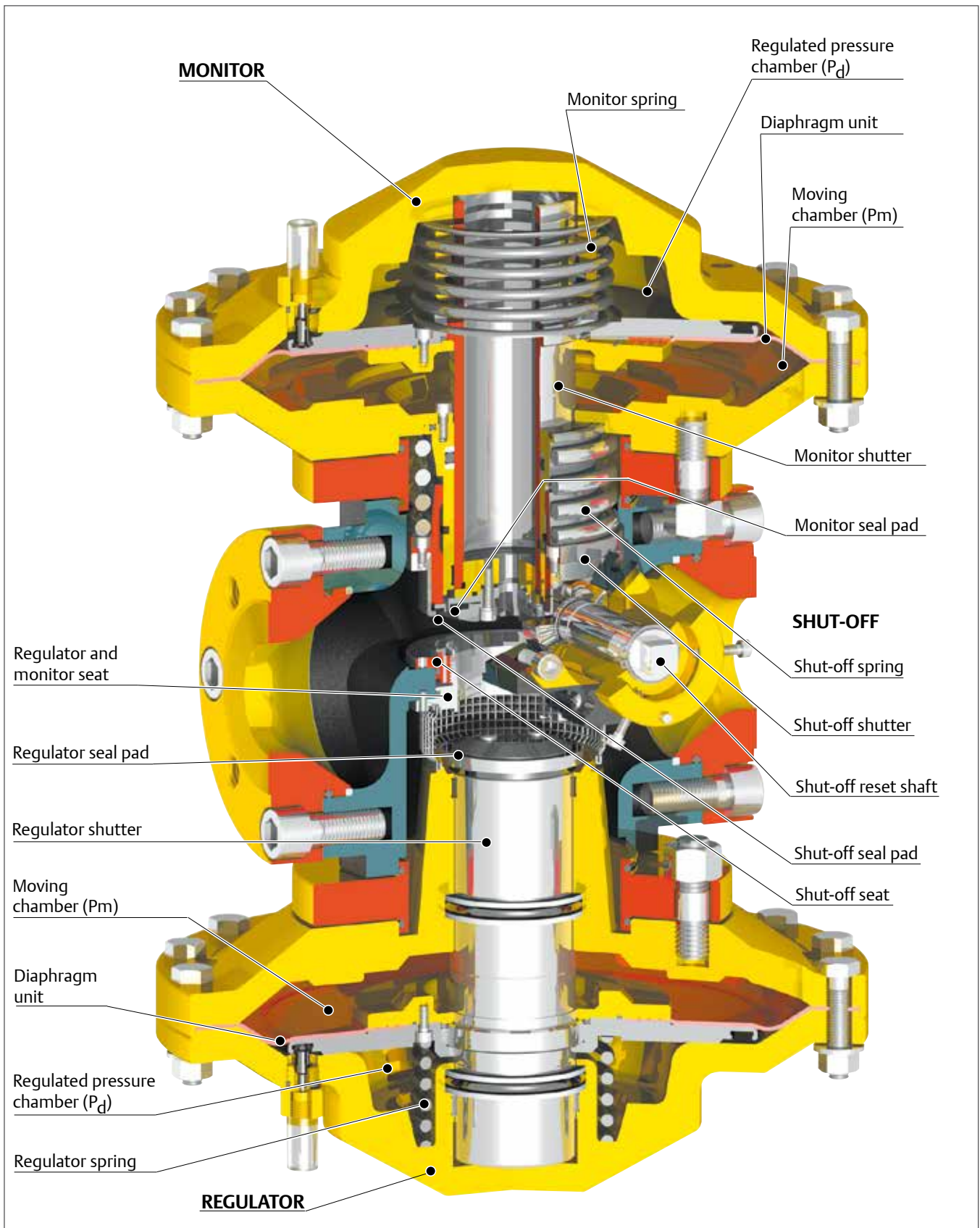

Operation

HOW THE REGULATOR WORKS

The Diaphragm Unit (permanently connected to the shutter) divides the regulator control head into two chambers.

One of the chambers is connected to regulated pressure (P_d), and the other to moving pressure (P_m) produced by the pilot according to pressure downstream.

Due to lack of pressure, the regulator spring acts on the diaphragm unit and closes the shutter.

The shutter moves to its open position when the force produced by moving pressure acting on the diaphragm unit becomes greater than the force produced by downstream regulated pressure (P_d) added to the load of the regulator spring. The shutter stays idle when the two forces are equal under these conditions, downstream pressure is equal to the system's set value.

Any change in requested flow-rate produces a variation in downstream regulated pressure and the regulator controlled by the pilot opens or closes to deliver the requested flow-rate while keeping downstream pressure uniform.

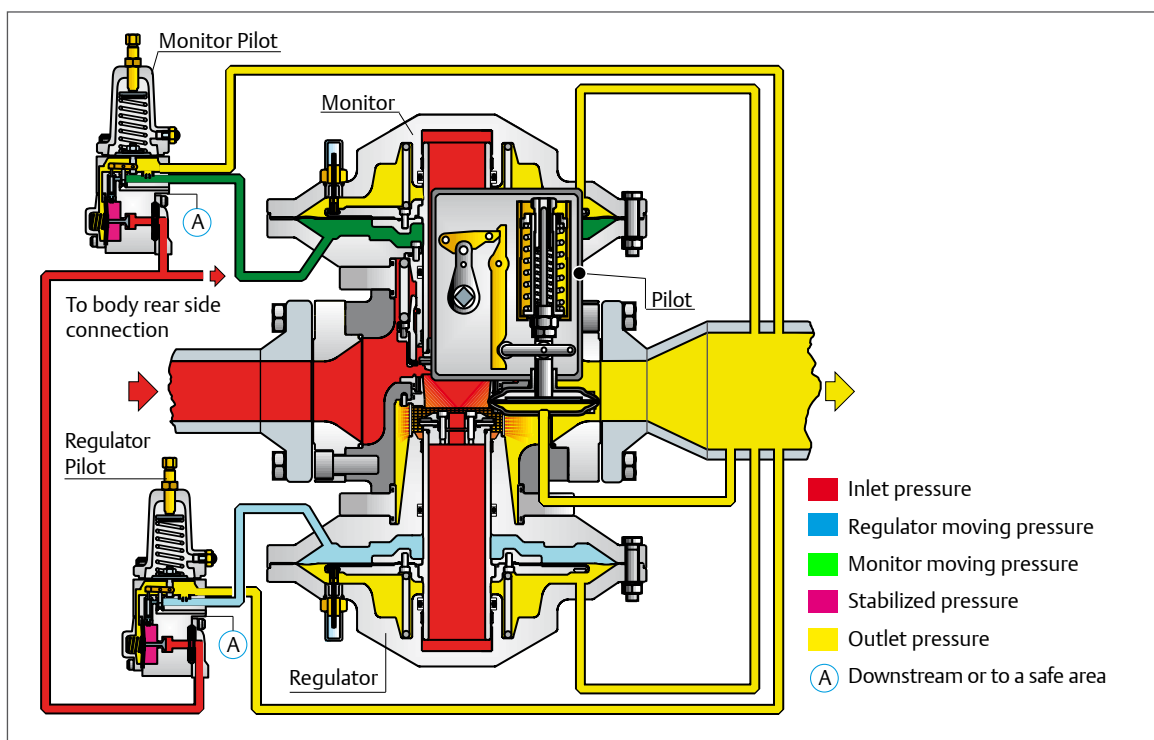

HOW THE MONITOR WORKS

The Monitor or emergency regulator is used as a safety device in gas pressure reduction systems. The purpose of this device is to protect the system against possible overpressure, while keeping the reduction line in service.

The monitor controls downstream pressure at the same point as the main regulator and is set a little higher than the latter.

Under normal duty, the monitor is fully open as it detects a pressure value lower than its set value. If, due to any regulator fault, downstream pressure increases, when it exceeds the tolerated level, the monitor comes into operation and adjusts pressure to its own set value.

HOW THE SHUT-OFF DEVICE WORKS

The shut-off device has a shutter and its own seat, and is provided with functions independent of the regulator/monitor. The shutter can be opened by hand only, by rotating the shut-off reset shaft anti-clockwise. To keep the shutter open, actuator-pilot series OS/80X or series OS/80X-PN is used both are designed to operate on maximum and minimum pressure, on maximum only, on minimum only.

When the system's downstream pressure is at normal operating value, the actuator-pilot remains set and prevents the shut-off reset shaft from turning by keeping the shut-off shutter open.

When downstream pressure varies beyond its set limits, the actuator-pilot releases the reset shaft and the shutter is closed by the thrust of the spring.

Cronos Regulators

Features

Applications

CRONOS series regulators are used in reduction, distribution and conveying stations of suitably filtered natural gas.
They can also be used for air, propane, butane, LPG, city gas, nitrogen, carbon dioxide and hydrogen.

Technical Features

Flange rating PN 16 - ANSI 150

Allowable pressure	PS	: up to 20 bar
Inlet pressure range	b_{pu}	: 0.2 to 20 bar
Set range	W_d	: 0.01 to 16 bar
Min.operating differential pres.	Δp_{min}	: 0.2 bar

Flange rating PN 25/40 - ANSI 300/600

Allowable pressure	PS	: up to 100 bar
Inlet pressure range	b_{pu}	: 1 to 100 bar
Set range	W_d	: 0.5 to 80 bar
Min.operating differential pres.	Δp_{min}	: 0.5 bar

Functional Features

Accuracy class	AC	: up to \pm 1%
Lock-up pressure class	SG	: up to + 5%
Class of lock-up pressure zone	SZ	: up to 5%

Shut-off device

Accuracy class	AG	: up to \pm 1%
Response time	t_a	: \leq 1 s

Flanged connections

Same Inlet and outlet	: DN 25 - 50 - 80
Different Inlet and outlet	: DN 25 x 100 - 50 x 150 - 80 x 250

Temperature

Standard version
Working: -10 °C +60 °C

Low temperature version
Working: -20 °C +60 °C

Materials

Body	: Steel
Flanges and covers	: Steel
Regulator shutter	: Steel
Shut-off shutter	: Steel
Seat	: Stainless steel
Diaphragms	: Fabric NBR+PVC/Nitrile rubber
Pads	: NBR Nitrile rubber

Calculation Procedures

- Symbols**
- Q = Natural gas flow rate in Stm³/h
 - P1 = Absolute inlet pressure in bar
 - P2 = Absolute outlet pressure in bar
 - C_g = Flow rate coefficient
 - C1 = Body shape factor
 - d = Relative density of the gas

Flow Coefficients

Horizontal Flow

DN		Standard Model				Model with SR				Model with SRS				Model with Widened Outlet			
		C	CB	CC	CCB	C	CB	CC	CCB	C	CB	CC	CCB	C	CB	CC	CCB
25	Cg	550	510	510	500	540	500	500	490	500	460	460	450	580	550	550	540
	C1	30	30.5	30.5	31	30	30.5	30.5	31	33	33.5	33.5	34	30	31	31	31
50	Cg	2250	2080	2080	2050	2200	2030	2030	2000	1900	1780	1780	1750	2300	2100	2100	2050
	C1	29	30	30	30.5	29	30	30	31	32	33	33	33.5	29	30	30	30.5
80	Cg	5100	4800	4800	4700	5000	4700	4700	4600	4200	4000	4000	3900	5200	4850	4850	4800
	C1	29	30	30	31	29	30	30	31	32	33	33	34	29	30	30	31

90° flow

DN		Standard Model			Model with SR			Model with SRS			Model with Widened Outlet		
		CBS	CCS	CCBS	CBS	CCS	CCBS	CBS	CCS	CCBS	CBS	CCS	CCBS
25	Cg	450	450	440	440	440	430	400	400	390	475	475	470
	C1	30	30	31	30	30	31	33	33	34	30	30	31
50	Cg	1850	1850	1800	1800	1800	1750	1650	1650	1600	1900	1900	1850
	C1	30	30	31	30	30	31	32	32	33	30	30	31
80	Cg	4300	4300	4200	4200	4200	4100	3500	3500	3400	4400	4400	4300
	C1	30	30	31	30	30	31	33	33	34	30	30	31

Flow Rate Q Sub-critical state with $P2 > \frac{P1}{2}$

$$Q = 0.525 \cdot C_g \cdot P1 \cdot \sin \left(\frac{3417}{C1} \cdot \sqrt{\frac{P1-P2}{P1}} \right)^{\text{Deg}}$$

Critical state with $P2 \leq \frac{P1}{2}$

$$Q = 0.525 \cdot C_g \cdot P1$$

For other gases with different densities, the flow rate calculated with the above formulas must be multiplied by the correction factor:

$$F = \sqrt{\frac{0.6}{d}}$$

Gas	Relative Density d	Factor F
Air	1	0.78
City gas	0.44	1.17
Butane	2.01	0.55
Propane	1.53	0.63
Nitrogen	0.97	0.79
Carbon dioxide	1.52	0.63
Hydrogen	0.07	2.93

Cronos Regulators

DN Size

Calculate the required C_g with the following formula:

Sub-critical state with $P_2 > \frac{P_1}{2}$

$$C_g = \frac{Q}{0.525 \cdot P_1 \cdot \sin \left(\frac{3417}{C_1} \cdot \sqrt{\frac{P_1 - P_2}{P_1}} \right)^{Deg}}$$

Critical state with $P_2 \leq \frac{P_1}{2}$

$$C_g = \frac{Q}{0.525 \cdot P_1}$$

N.B. The above formulas apply to natural gas flow rate only. If the flow rate value (Q) refers to other gasses, divide it by the correction factor F (see table).

Select the diameter of the regulator with C_g higher than calculated value (see table).
After finding the DN of the regulator, check that gas speed on the seat does not exceed 120 m/sec, using the following formula:

$$V = 345.92 \cdot \frac{Q}{DN^2} \cdot \frac{1 - 0.002 \cdot P_u}{1 + P_u}$$

- V = Velocity (m/s)
- 345.92 = Numerical constant
- Q = Flow rate under standard conditions (Stm³/h)
- DN = Regulator nominal diameter (mm)
- P_u = Inlet pressure in relative value (bar)



Detail of reducing unit with CB-SRS. Right to left gas flow

Pilots

The following pilots are used with CRONOS series regulator with built-in shut-off device:

- **OS/80X** series: Spring loaded pneumatic device
- **OS/80X-PN** series: Pneumatic device controlled by **PRX** series pilots

OS/80X

The OS/80X series pilot is supplied in different models according to set ranges required.

Technical Features

Model	Servomotor Body Resistance (bar)	Overpressure Set Range W_{do} (bar)		Underpressure Set Range W_{du} (bar)	
		Min.	Max.	Min.	Max.
OS/80X-BP	5	0.03	2	0.01	0.60
OS/80X-BPA-D	20				
OS/80X-MPA-D	100	0.50	5	0.25	4
OS/80X-APA-D		2	10	0.30	7
OS/84X		5	41	4	16
OS/88X		18	80	8	70

Materials

OS/80X

Servomotor body: OS/80X-BP, OS/80X-BPA-D Aluminum
OS/80X-MPA-D, OS/80X-APA-D Steel
Diaphragm: Fabric NBR+PVC/Nitrile rubber
O-ring: NBR Rubber

OS/84X, OS/88X

Servomotor body: Brass
Lip seal: Teflon (PTFE)
O-ring: NBR Rubber



OS/80X-BP

OS/80X-PN

The OS/80X-PN series pilot is supplied in two models:

OS/80X-PN: Pressure range 0.5 to 40 bar

Appliance made of an OS/80X-APA-D set at about 0.4 bar and a variable number of PRX/182 pilots for overpressure and PRX/181 for underpressure, as many as necessary to control different points of the installation.

OS/84X-PN: Pressure range 30 to 80 bar

Appliance made of an OS/84X set at about 20 bar and a variable number of PRX-AP/182 pilots for overpressure and PRX-AP/181 for underpressure, as many as necessary to control different points of the installation.

Technical Features

Model	Servomotor Body Resistance (bar)	Overpressure Set Range W_{do} (bar)		Underpressure Set Range W_{du} (bar)	
		Min.	Max.	Min.	Max.
OS/80X-PN	100	0.5	40	0.5	40
OS/84X-PN	100	30	80	30	80

Materials

PRX/181/182, PRX-AP/181/182

Body: Steel
Diaphragm: Fabric-finished NBR
O-ring: NBR Rubber

Cronos Regulators

Pilots

PS/ Series



Cronos series regulators are equipped with the PS/ or PRX/ series pilots.

Application	Allowable Pressure PS (bar)	Set Range W _d (bar)	Body and Covers Material
Regulator or Monitor			
PS/79-1	25	0.01 - 0.5	Aluminium
PS/79-2		0.5 - 3	

1/4" NPT female threaded connections



Application			Allowable Pressure PS (bar)	Set Range W _d (bar)	Body and Covers Material
Regulator or Monitor	Operating Monitor				
		Regulator	Monitor		
PS/79	PSO/79	REO/79	100	0.5 - 40	Steel
PS/80	PSO/80	REO/80		1.5 - 40	

1/4" NPT female threaded connections

All PS/ series pilots are supplied with a filter (5 μ filtering degree) and built-in pressure stabilizer, with the exception of pilots PSO/79 and PSO/80.

PRX/ Series



Application			Allowable Pressure PS (bar)	Set Range W _d (bar)	Body and Covers Material
Regulator or Monitor	Operating Monitor				
		Regulator	Monitor		
PRX/120	PRX/120	PRX/125	100	1 - 40	Steel
PRX-AP/120	PRX-AP/120	PRX-AP/125		30 - 80	

1/4" NPT female threaded connections

The SA/2 pressure pre-reducer must be used with PRX/ series pilots.

SA/2



The pressure pre-reducer is equipped with a 5 μ filtering degree filter and is suitable for heating.

Model	Allowable Pressure PS (bar)	Supplied Pressure	Body and Covers Material
SA/2	100	3 bar + Downstream pressure	Steel

1/4" NPT female threaded connections

FU



When the pressure difference between upstream and downstream is below 10 bar, SA/2 can be used with the following FU filter.

Model	Allowable Pressure PS (bar)	Filtering Degree	Body and Covers Material
FU	100	5 μ	Steel

1/4" NPT female threaded connections

Booster Valves



Model	Allowable Pressure PS (bar)	Set Range W _d (bar)	Body and Covers Material
V/31-1	19	0.025 - 0.55	Aluminium
PRX/131	100	0.5 - 40	Steel
PRX-AP/131		30 - 80	

1/4" NPT female threaded connections

Operating Monitor and Booster Valve

OPERATING MONITOR

The “operating monitor” has two functions: under normal duty, it reduces pressure in the intermediate section between the two regulators, but, if the main regulator fails, it comes into operation as an emergency regulator.

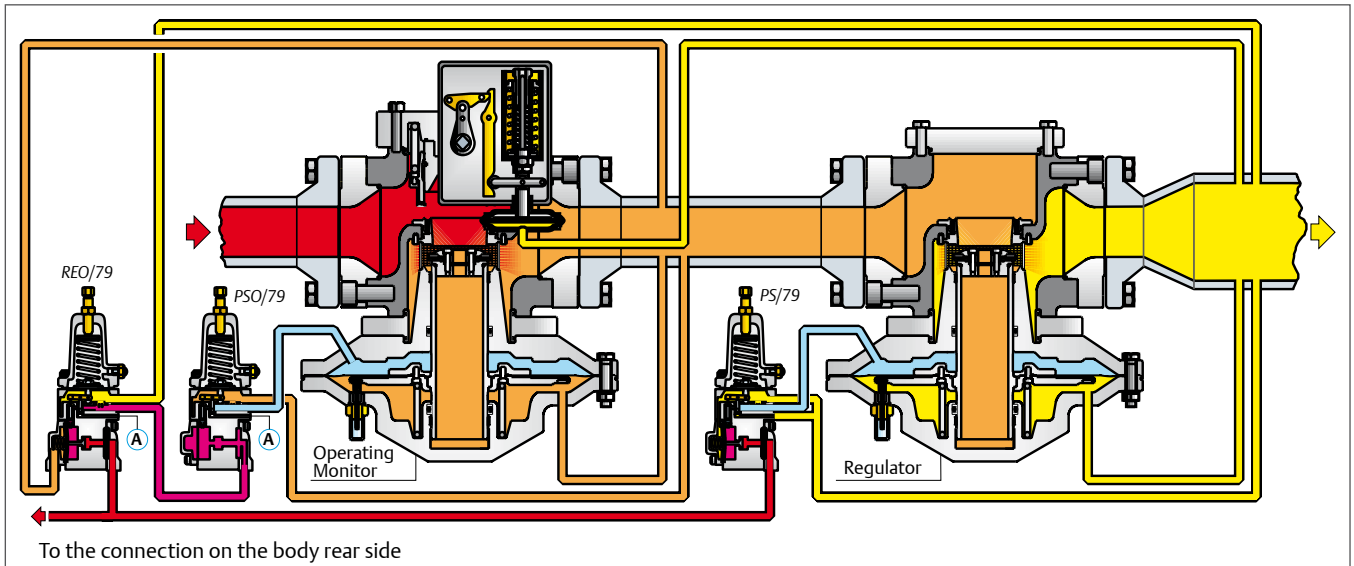

BOOSTER VALVE

The booster valve is fitted on the monitor-regulator system which branches off from the monitor drive pressure circuit, so that the monitor operates more quickly.

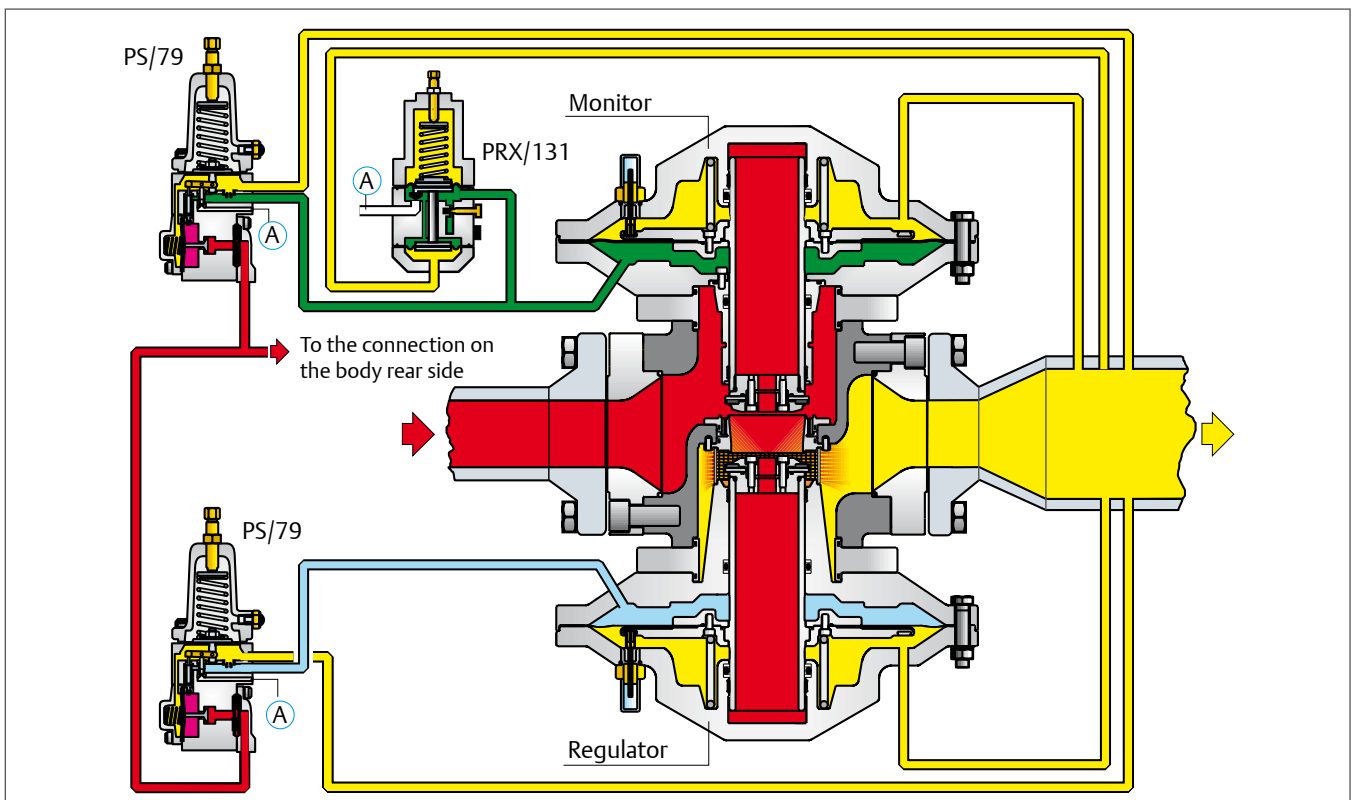

- Inlet pressure
- Intermediate pressure
- Regulator moving pressure
- Monitor moving pressure
- Stabilized pressure
- Outlet pressure
- A Downstream or to a safe area

Cronos Regulators

Silencers

SR

This silencer is fitted near the regulator shutter and is highly efficient up to a theoretical speed of 80 m/s calculated at the outlet flange.

Beyond this speed could be necessary to act on the noise generated by the expansion cone usually installed downstream of the regulator.

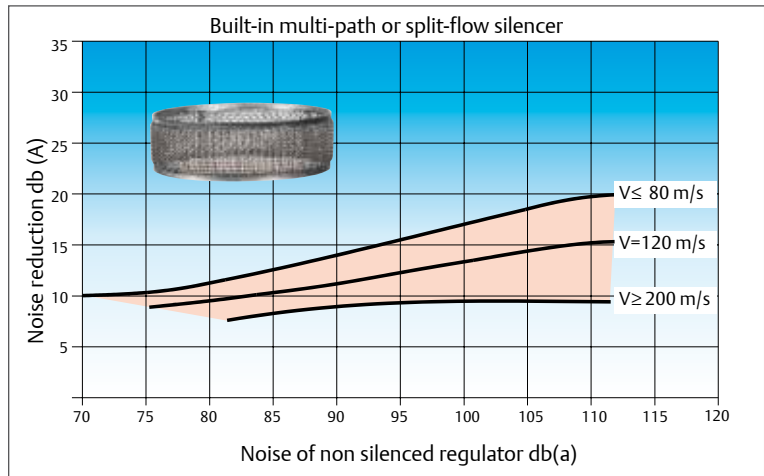

SRS

The SRS silencer consists of an SR silencer plus a widened outlet flange in which a second silencer is fitted.

The second silencer has an initial multi-path section and a second multi-stage section.

This silencer is highly efficient under all operating conditions, is not limited by the theoretical speed on the regulator outlet flange.

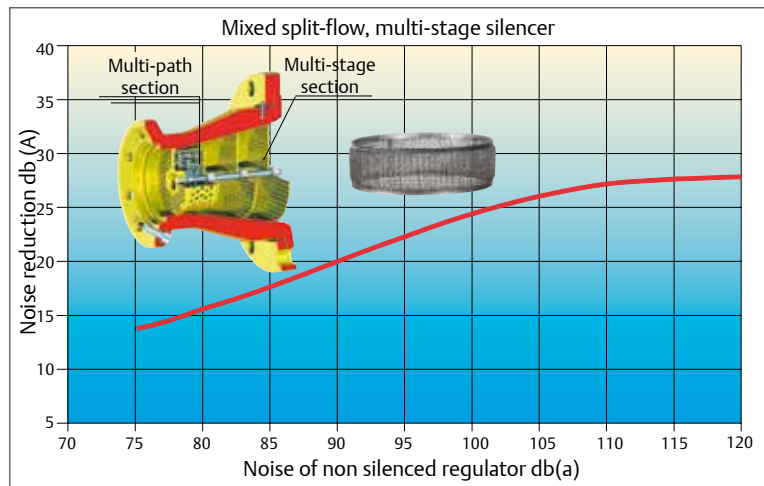

STP

Habitually used down-stream of SRS silencers but can also be combined with the SR silencer.

Overall reduction in noise level is the sum of the reduction produced by SR or SRS plus the STP induced reduction.

The STP silencer consists of one or more porous channels clad with soundproofing material.

Sound penetrates inside the soundproofing layer and is transformed into heat by friction.

The silencer is fitted in the pipe and is secured with two flanges.

Two types of silencers are supplied:

- STP10 10 dB(A) attenuation, with length of approximately 1m
- STP10 20 dB(A) attenuation, with length of approximately 2m

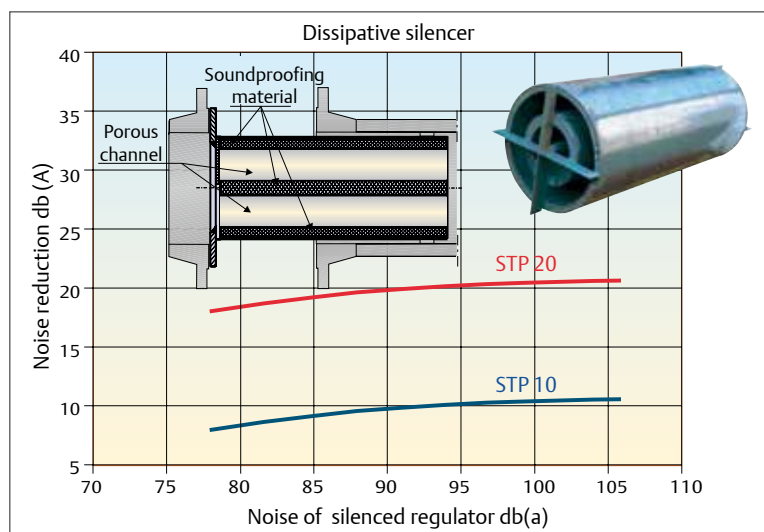

Accessories

PROPORTIONAL TRAVEL TRANSMITTER

In order to communicate the valve position, a potentiometer-type straightaway position transmitter is used connected to the regulator travel indicator. Thanks to this transducer, it is possible to know accurately the valve position and thus have correct information on the regulator operating condition.

It is supplied in two models:

- PA1/25 suitable for Cronos DN 25-50
- PA1/50 suitable for Cronos DN 80

This transducer features a single element as foreseen by EN 50020 standards and can thus be used in hazardous areas.

Single element transducers, if fitted in intrinsic safety circuits, should be protected through suitable safety barriers anyway.



Model		PA1/25	PA1/50
Useful electrical travel	mm	26	51
Resistance	kΩ	1	5
Resolution	mm	infinite	
Suggested current	μA	<1	
Max. current	mA	≤10	
Max. voltage	V	25	60
Working temperature	°C	-30 °C +100 °C	

PROXIMITY SWITCH

In order to send the shut-off or the regulator/monitor opening/closing signal, a proximity switch suitable for installation in hazardous area is used.

The use of this switch foresees the application of an intrinsic safety separation barrier which should be installed in safe area.

The distance between the proximity switch and the barrier should be calculated according to the type of gas and installation electrical specifications.



The proximity switch should be positioned at about 0.5 mm from the stem (S). The adjustment is made by means of adjusting nuts.

On request it is possible to supply the pilot in the version with two proximity switches in order to indicate extreme positions of valve opening/closing.

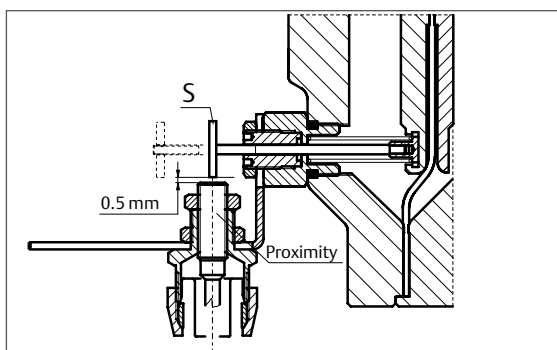

Regulator/Monitor installation

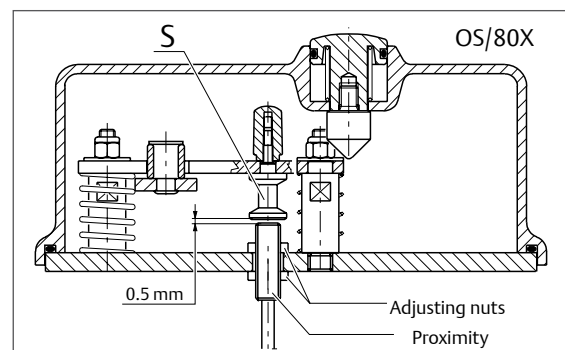

Pilot installation

Cronos Regulators

Accessories

ELECTROVALVE FOR REMOTE CONTROLLED CLOSURE

The OS/80X and the OS/80X-PN equipped with a shut-off device for minimum pressure, can be equipped with a 3-way valve with explosion-proof construction to permit remote-controlled closure.

IT/3V THREE-WAY VALVE FOR SETTING CONTROL (P_U max 50 bar)

It allows the OS/80X operation and setting control, without having to change the regulator setting.

The valve is installed on the OS/80X control line and it must be connected to a suitable pressure source that is capable of reaching the settings of the OS/80X.

The IT/3V three-way valve is of the spring-return type and it is equipped with a safety lock plate (B) on the control knob (Q).

When the plate (B) is pivoted, pressure on the knob (Q) makes it possible to put the sensitive member into communication with a pressure source, thus making it possible to perform operation and setting tests.

Upon completion of the procedures, releasing the knob will reset normal running conditions. The safety lock plate on the knob prevents accidental maneuvers.

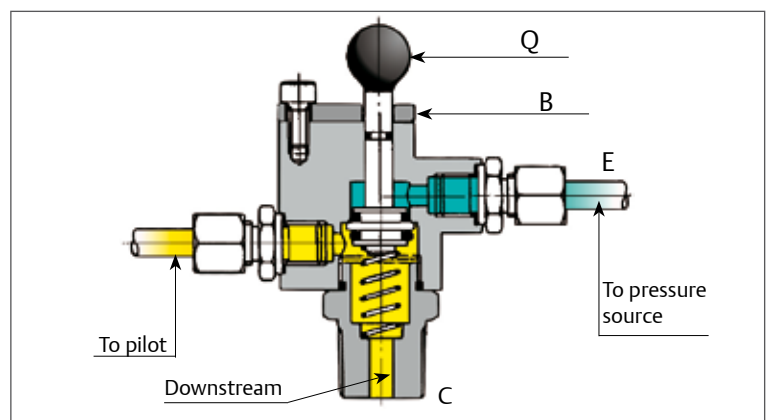
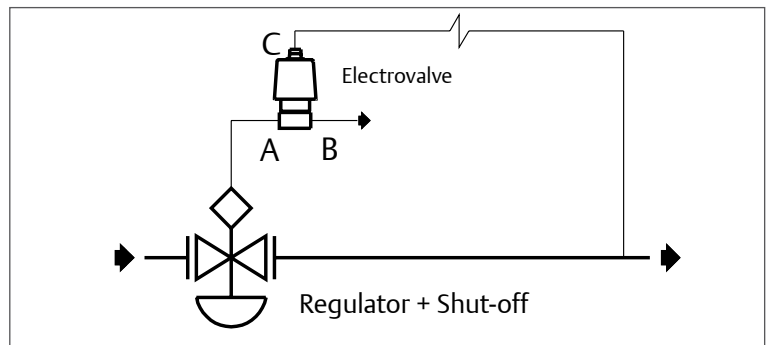

MIC/25 Underground Module

Installation

The central cross-shaped body is designed so that the actuator-pilot can be installed both at front and rear. This facility combined with body rotation enables all types of orientation.

For orientations different from those shown below, please contact our Technical Department.

Horizontal Flow

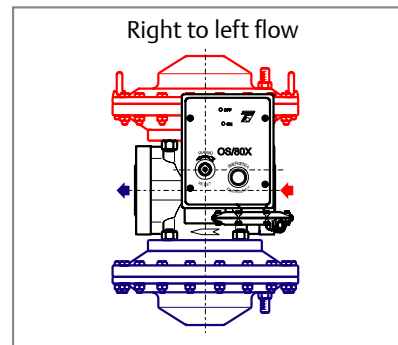
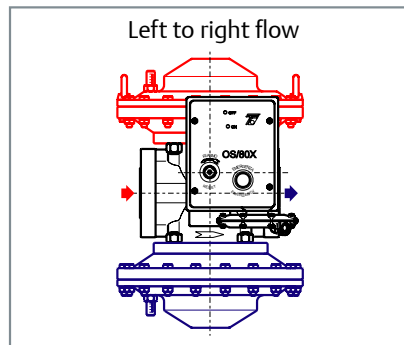

Vertical Flow

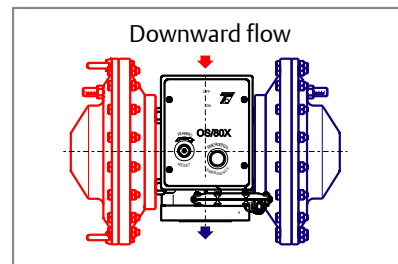
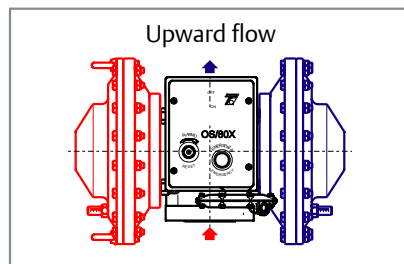

90° Flow

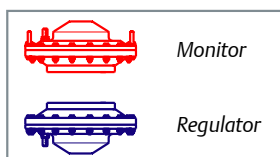
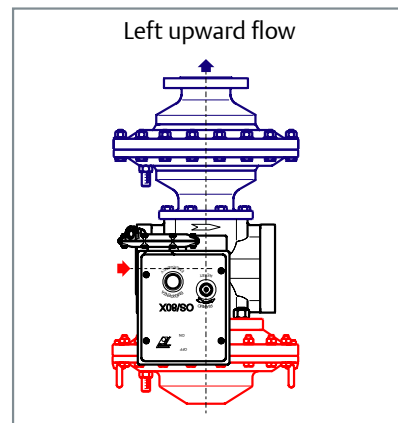
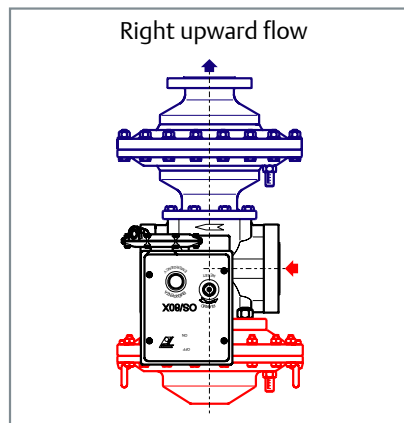
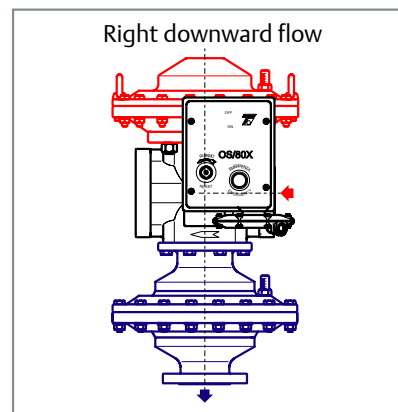
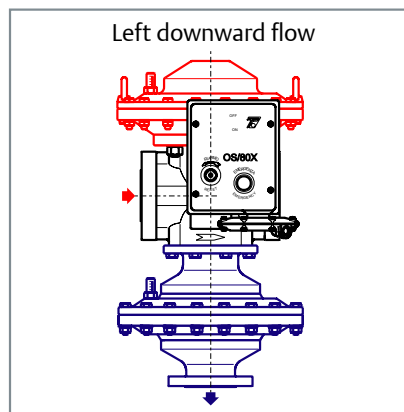

Cronos Regulators

Examples of Connections

PS/79-1 PS/79-2 Series

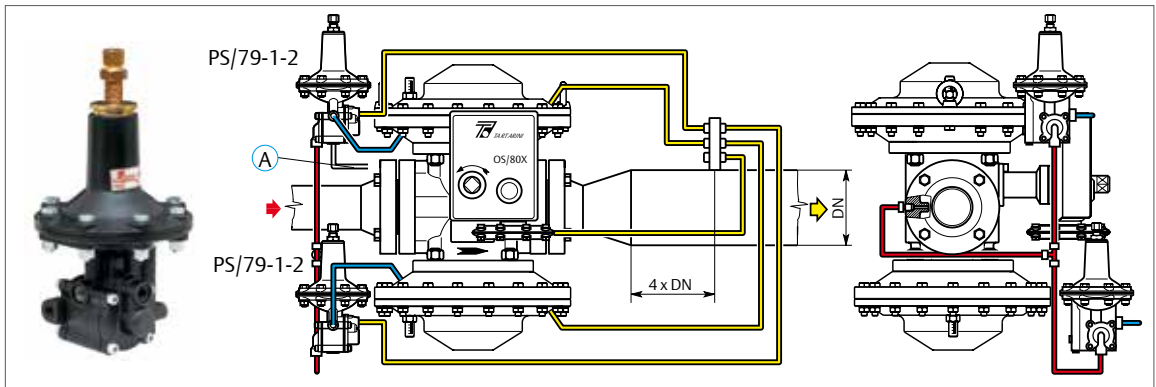

PS/79 Series

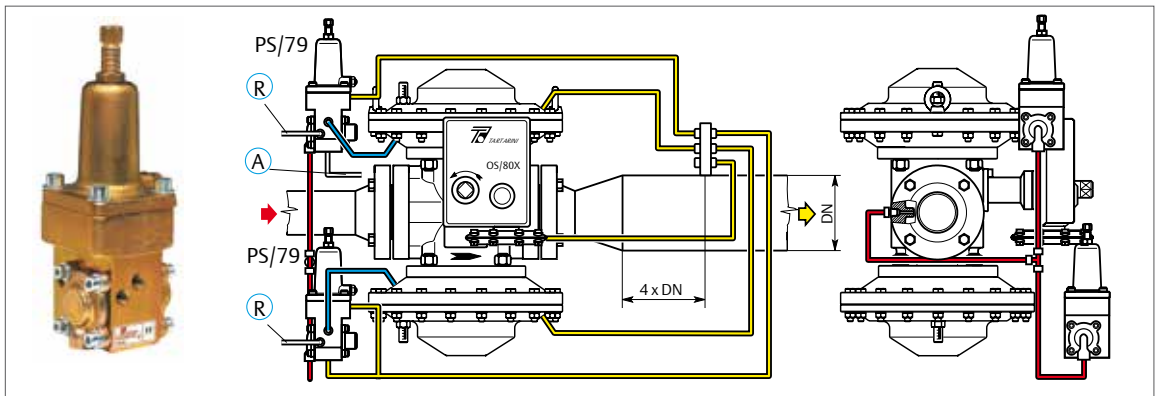

PS/80 Series

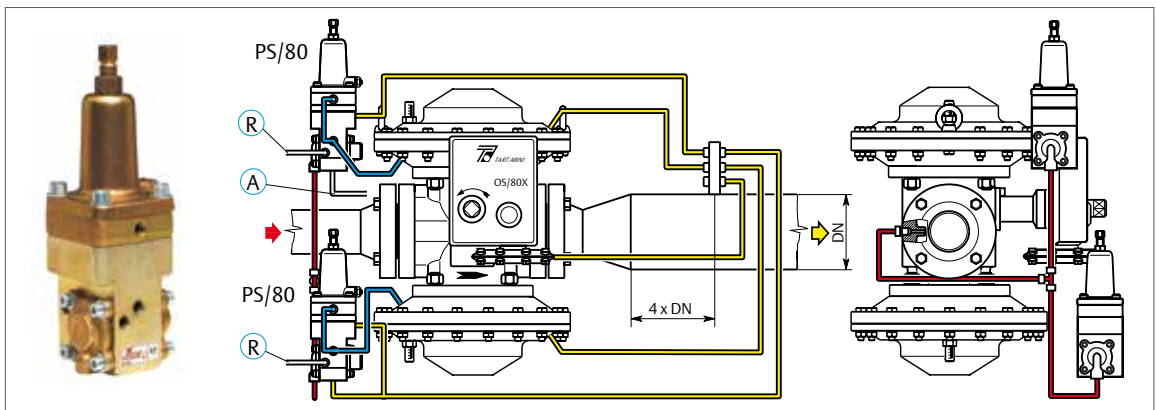

PRX Series

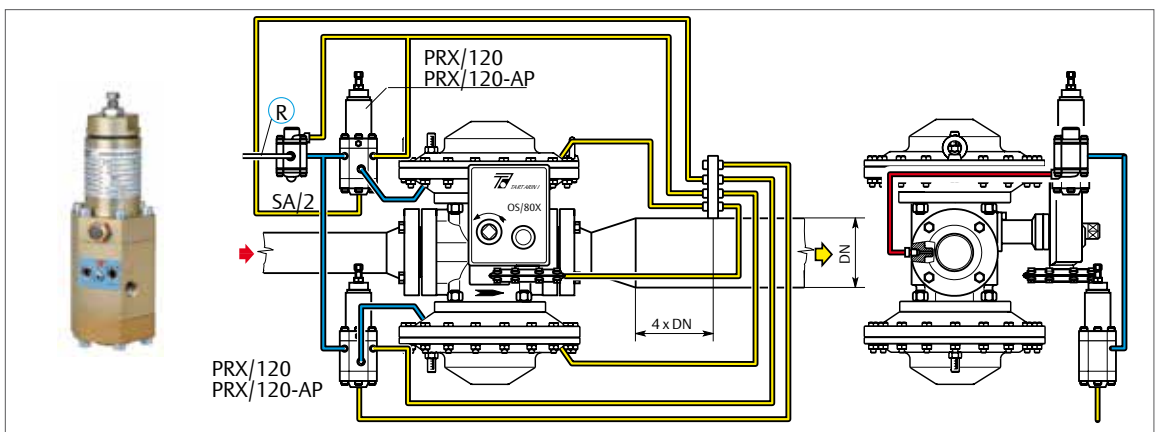

■ Inlet pressure
 ■ Moving pressure
 ■ Outlet pressure
 (A) Downstream or to a safe area
 (R) To the heating system

Horizontal Flow Dimensions (mm)

Standard and SR

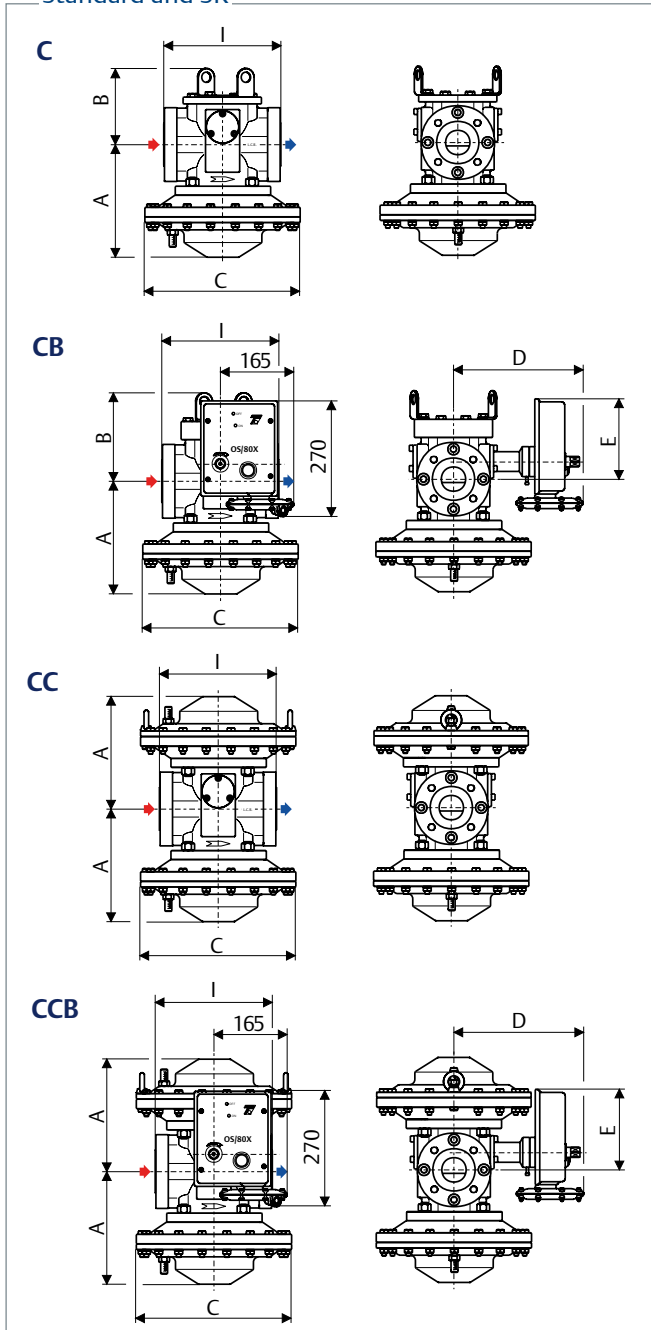

Widened outlet and SRS

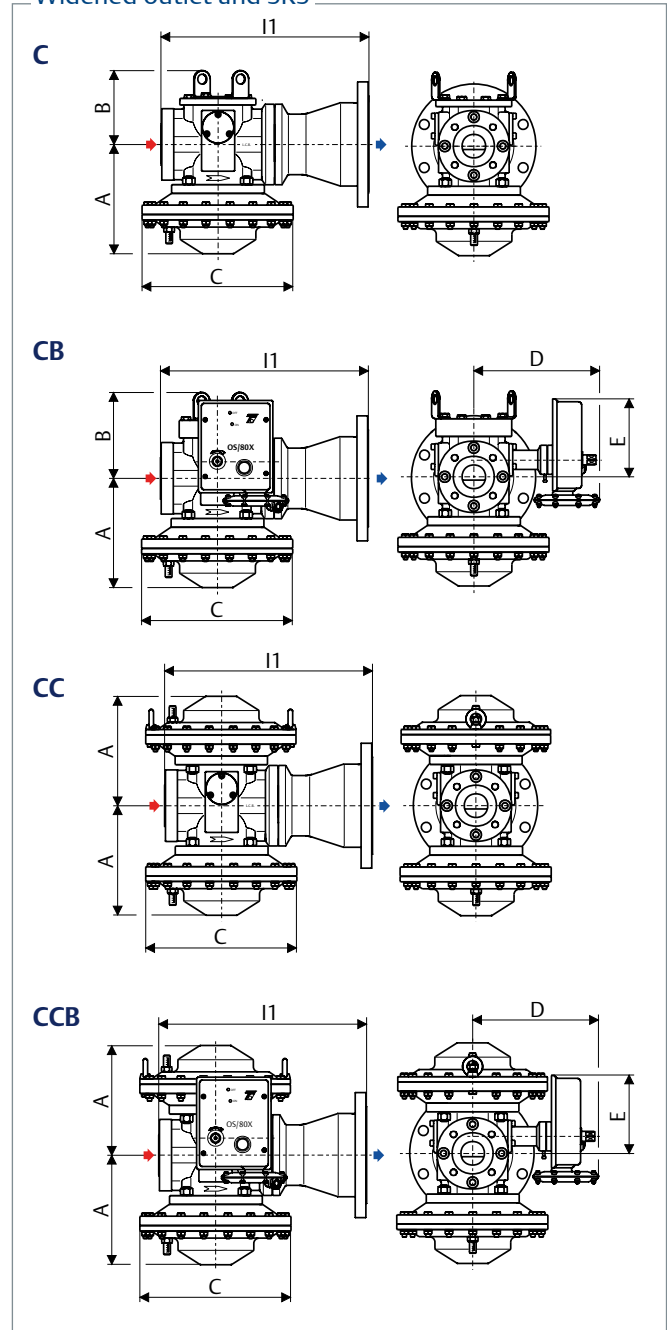

DN	Overall Dimensions (mm)										Face-to-Face (mm)					
	PN 16 ANSI 150					PN 25/40 ANSI 300/600					PN 16 ANSI 150		PN 25/40 ANSI 300		ANSI 600	
	A	B	C	D	E	A	B	C	D	E	I	I1	I	I1	I	I1
25	215	180	285	260	170	220	180	225	260	170	184	350	197	353.5	210	360
50	245	195	335	285	175	260	195	287	285	175	254	465	267	471.5	286	482
80	330	260	400	325	185	350	260	400	325	185	298	570	317	590	337	600

Threaded 1/4" NPT female impulse connections

Cronos Regulators

90° Flow Dimensions (mm)

Standard and SR

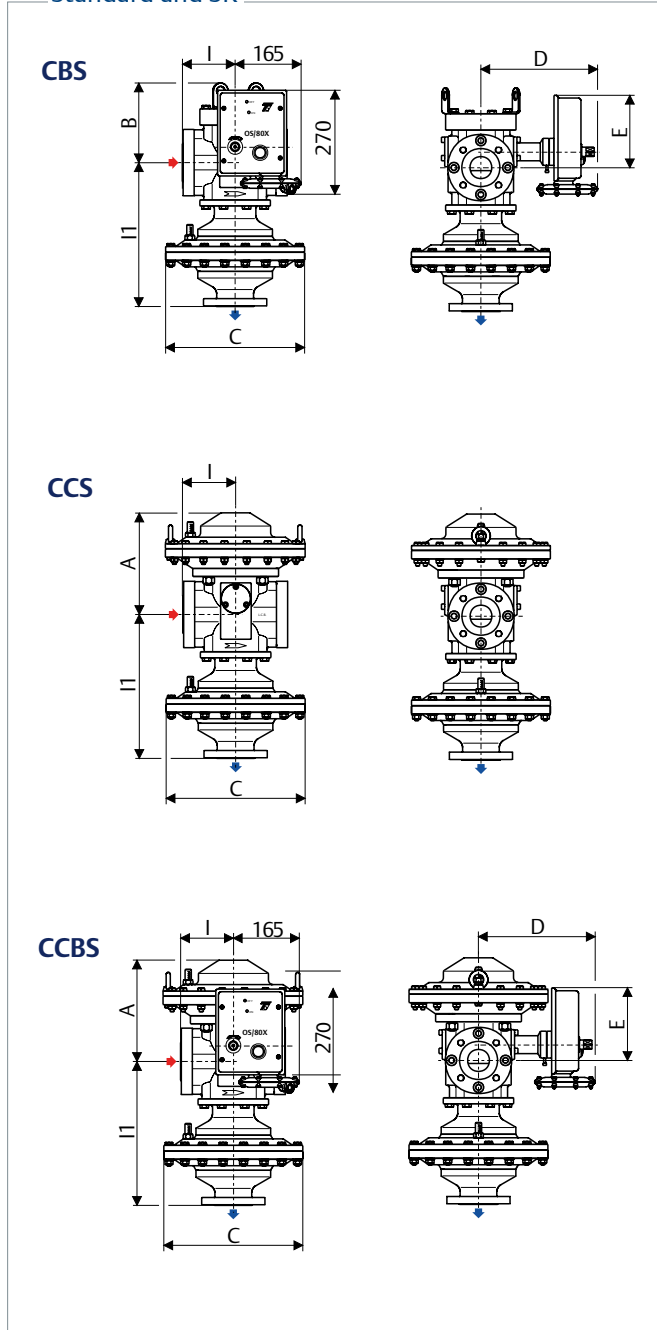

Widened outlet and SRS

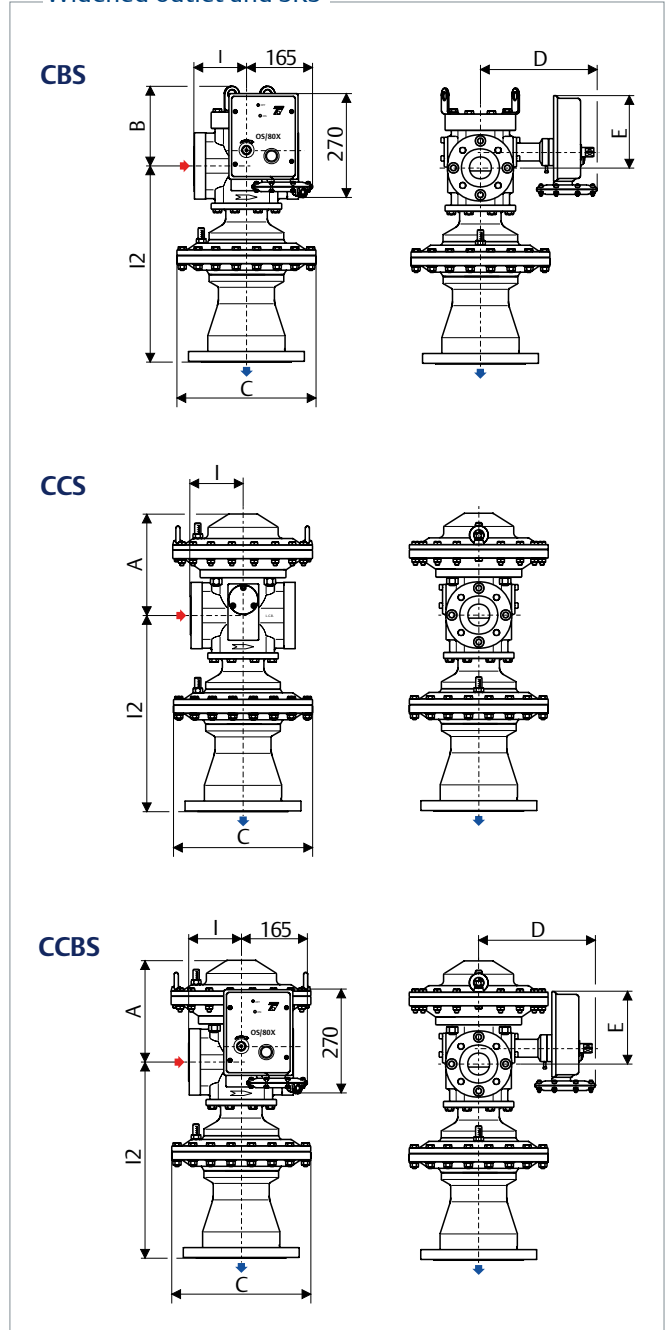

DN	Overall Dimensions (mm)										Face-to-Face (mm)								
	PN 16 ANSI 150					PN 25/40 ANSI 300/600					PN 16 ANSI 150			PN 25/40 ANSI 300			ANSI 600		
	A	B	C	D	E	A	B	C	D	E	I	I1		I	I1	I2	I	I1	I2
25	215	180	285	260	170	220	180	225	260	170	92	280	386	98.5	295	385	105	295	385
50	245	195	335	285	175	260	195	287	285	175	127	347	473	133.5	370	484	143	370	484
80	330	260	400	325	185	350	260	400	325	185	149	450	622	158.5	485	648.5	168.5	485	648.5

Threaded 1/4" NPT female impulse connections

Weights

Horizontal Flow

DN	Standard and SR (kg)								Widened Outlet and SRS (kg)							
	PN 16 ANSI 150				PN 25/40 ANSI 300/600				PN 16 ANSI 150				PN 25/40 ANSI 300/600			
	C	CB	CC	CCB	C	CB	CC	CCB	C	CB	CC	CCB	C	CB	CC	CCB
25	36	38	56	58	37	39	61	63	49	51	69	71	56	58	78	80
50	62	66	96	100	74	78	118	122	87	91	121	125	109	113	153	157
80	128	142	191	197	171	185	271	277	190	204	253	259	273	279	373	379

90° Flow

DN	Standard and SR (kg)						Widened Outlet and SRS (kg)					
	PN 16 ANSI 150			PN 25/40 ANSI 300/600			PN 16 ANSI 150			PN 25/40 ANSI 300/600		
	CBS	CCS	CCBS	CBS	CCS	CCBS	CBS	CCS	CCBS	CBS	CCS	CCBS
25	40	56	58	43	63	65	53	69	71	60	80	82
50	72	102	106	92	132	136	97	127	131	127	167	171
80	159	208	214	225	319	325	221	270	286	327	421	427



CCB

Industrial Regulators

Emerson Process Management Regulator Technologies, Inc.

USA - Headquarters

McKinney, Texas 75070 USA
Tel: +1 800 558 5853
Outside US: +1 972 548 3574

Europe

Bologna 40013, Italy
Tel: +39 051 419 0611

Asia-Pacific

Shanghai 201206, China
Tel: +86 21 2892 9000

Middle East and Africa

Dubai, United Arab Emirates
Tel: +011 971 4811 8100

Natural Gas Technologies

Emerson Process Management Regulator Technologies, Inc.

USA - Headquarters

McKinney, Texas 75070 USA
Tel: +1 800 558 5853
Outside US: +1 972 548 3574

Europe

Bologna 40013, Italy
Tel: +39 051 419 0611
Chartres 28008, France
Tel: +33 2 37 33 47 00

Asia-Pacific

Singapore 128461, Singapore
Tel: +65 6770 8337

Middle East and Africa

Dubai, United Arab Emirates
Tel: +011 971 4811 8100

LP-Gas Equipment

Emerson Process Management Regulator Technologies, Inc.

USA - Headquarters

McKinney, Texas 75070 USA
Tel: +1 800 558 5853
Outside US: +1 972 548 3574

TESCOM

Emerson Process Management Tescom Corporation

USA - Headquarters

Elk River, Minnesota 55330-2445 USA
Tel: +1 763 241 3238
+1 800 447 1250

Europe

Selmsdorf 23923, Germany
Tel: +49 38823 31 287

Asia-Pacific

Shanghai 201206, China
Tel: +86 21 2892 9499

For further information visit www.emersonprocess.com/regulators

Our Global Product Brands:



The Emerson logo is a trademark and service mark of Emerson Electric Co. All other marks are the property of their prospective owners. Fisher, Tartarini, Francel, Emerson Process Management and the Emerson Process Management design are marks of the Emerson Process Management group of companies.

The contents of this publication are presented for informational purposes only, and while every effort has been made to ensure their accuracy, they are not to be construed as warranties or guarantees, express or implied, regarding the products or services described herein or their use or applicability. We reserve the right to modify or improve the designs or specifications of such products at any time without notice.

Emerson Process Management does not assume responsibility for the selection, use or maintenance of any product. Responsibility for proper selection, use and maintenance of any Emerson Process Management product remains solely with the purchaser.

O.M.T. **Officina Meccanica Tartarini S.R.L.**, Via P. Fabbri 1, I-40013 Castel Maggiore (Bologna), Italy
R.E.A 184221 BO Cod. Fisc. 00623720372 Part. IVA 00519501209 N° IVA CEE IT 00519501209, Cap. Soc. 1.548 000 Euro i.v. R.I. 00623720372 - M BO 020330

Francel SAS, 3 Avenue Victor Hugo, CS 80125, Chartres 28008, France
SIRET 552 068 637 00057 APE 2651B, N° TVA : FR84552068637, RCS Chartres B 552 068 637, SAS capital 534 400 Euro