

Fisher[®] 8560 Eccentric Disc Butterfly Control Valve

Fisher 8560 high-performance valves (figures 1 and 2) feature a stainless steel disc with a soft or stainless steel seal ring. Soft seals provide excellent sealing capabilities in both directions. The pressure-assisted metal seal ring provides excellent shutoff against pressure applied in the recommended flow direction for both liquid and gas applications.

The NOVEX and Phoenix III metal seals are available for demanding applications requiring excellent shutoff capabilities. The splined-shaft valve combines with a variety of power actuators to form a reliable, high-performance control valve suitable for throttling applications requiring extremely low leakage rates.

Unless otherwise noted, all NACE references are to NACE MR0175-2002.



W8299

Figure 1. Fisher 8560 Valve with 1052 Actuator and FIELDVUE™ DVC6000 Digital Valve Controller



W6361 / IL

Figure 2. Fisher 8560 Single-Flange Valve



Specifications

Valve Sizes and End Connection Styles

NPS ■ 2, ■ 3, ■ 4, ■ 6, ■ 8, ■ 10, and ■ 12 valve size available in
 ■ wafer or ■ single-flanged style
 (NPS 2 available in wafer only)

Maximum Inlet Pressure⁽¹⁾

Carbon Steel and Stainless Steel Valve Bodies: Consistent with CL150 and 300 pressure-temperature ratings per ASME B16.34 unless limited by material temperature capabilities. NPS 2 is also consistent with CL600

Maximum Pressure Drops⁽¹⁾

Consistent with CL150 and 300 pressure-temperature ratings per ASME B16.34 except for PTFE, UHMWPE and Phoenix III seals which are derated at some higher pressure-temperature values. Refer to figure 5

Shutoff Classifications

■ **PTFE, Reinforced PTFE, and UHMWPE⁽³⁾ Seals:** Bidirectional shutoff to Class VI per ANSI/FCI 70-2 and IEC 60534-4. See figure 4.
 ■ **NPS 2 Metal Seal:** Bidirectional shutoff. 0.001% of maximum valve capacity (1/10) of Class IV per ANSI/FCI 70-2 and IEC 60534-4. Maximum Pressure drop is 51 bar (740 psi) forward and 6.9 bar (100 psi) reverse.
 ■ **NOVEX Seal:** For NPS 3 through 12. Unidirectional shutoff is 0.0001% of maximum valve capacity (1% of Class IV). See figure 4.
 ■ **Phoenix III Seal:** For NPS 3 through 12. Bidirectional shutoff to Class VI per ANSI/FCI 70-2 and IEC 60534-4. See figure 4. For the optional Phoenix III Fire-Tested seal⁽²⁾, consult your Emerson Process Management sales office

Construction Materials

Refer to table 2 for standard material selections and component temperature ranges

Material Temperature Capabilities⁽¹⁾

PTFE and Reinforced PTFE Seals: -46 to 232°C (-50 to 450°F)

UHMWPE⁽³⁾ Seal: -18 to 93°C (0 to 200°F)

NPS 2 Metal Seal: -46 to 538°C (-50 to 1000°F)

NOVEX Seal: -46 to 538°C (-50 to 1000°F)

Phoenix III: -46 to 232°C (-50 to 450°F)

Flow Characteristic

Approximately linear

Flow Direction

Refer to figure 6

Flow Coefficients

See table 1, the section titled Coefficients in this bulletin, and also Catalog 12

Flow Coefficient Ratio⁽⁴⁾

100 to 1

Noise Levels

See Catalog 12 for sound pressure level prediction

Disc Rotation

Clockwise to close (when viewing from the drive shaft end) through 90 degrees of disc rotation

Actuator/ Valve Action

With a diaphragm or piston rotary actuator, the valve action is field-reversible. Refer to information provided in the Installation section and figure 6

Valve Classification

Face-to-face dimensions of NPS 3 through 12 valves in CL150 or 300, meets API 609 or MSS-SP68 standards for face-to-face dimensions of wafer-style and single-flange valves (see figure 8)

(continued)

Specifications (continued)

Approximate Weights

VALVE SIZE, NPS	WAFER STYLE		SINGLE FLANGE	
	CL150	CL300	CL150	CL300
kg				
2 ⁽⁵⁾	4	4	---	---
3	5	6	6	11
4	9	10	11	18
6	13	15	16	27
8	21	24	27	42
10	34	44	40	78
12	49	64	62	131
Pounds				
2 ⁽⁵⁾	9.5	9.5	---	---
3	10	13	14	25
4	19	23	24	39
6	29	33	35	59
8	47	53	59	93
10	75	96	88	172
12	107	141	137	288

Mating Flange Capabilities

All sizes compatible with CL150 and 300, NPS 2 also compatible with CL600, flanges (schedule 80 or lighter, see figure 8, Dimension M)

Shaft Diameters

See figure 8

ENVIRO-SEAL™ Packing

This optional ■ PTFE or ■ graphite packing system provides improved sealing, guiding, and transmission of loading force to control liquid and gas emissions (see figure 7). See Bulletin 59.3:041 ENVIRO-SEAL Packing Systems for Rotary Valves for more information.

1. The pressure-temperature limits in this bulletin and any applicable standard or code limitation should not be exceeded.
 2. For component selection and applicable fire-tested standards and codes, consult your Emerson Process Management sales office (see table 2).
 3. UHMWPE stands for ultra high molecular weight polyethylene.
 4. Ratio of maximum flow coefficient to minimum usable flow coefficient.
 5. Weight of the CL600 NPS 2 valve is the same as the CL150 and CL300 values.

Features

- **Exceptional Shutoff**—Bidirectional soft seal ring with pressure assisting action (see figure 3) results in exceptional shutoff per Class VI.
- **Excellent Flow Control**—The eccentrically-mounted disc design provides an approximate linear flow characteristic and can be used for throttling or on/off control applications through 90 degrees of disc rotation.
- **Sour Service Capability**—Trim and bolting materials are available for applications involving sour service. These constructions comply with the recommendations of NACE MR0175-2002.
- **Improved Environmental Capabilities**—The optional ENVIRO-SEAL packing system is designed with improved sealing, guiding, and loading force transmission. The ENVIRO-SEAL packing system can control emissions to below the EPA (Environmental Protection Agency) limit of 100 ppm (parts per million) for valves.
- **Integral Shaft-to-Body Bonding**—Standard valve construction includes conductive packing to

provide electrical bonding for hazardous area applications.

- **Low Cost Maintenance**—Individual disc/shaft components can be replaced after disassembly due to sleeve and taper pin connections (see figure 3).

Installation

It is recommended that the valve drive shaft be mounted in a horizontal position as shown in figures 1 and 2. Operating conditions may require specific valve/actuator fail action, styles, positions and flow direction. Valves with NOVEX seal rings require mounting in the reverse flow direction. Refer to figure 6. Large valve/actuator assemblies may require additional support because of their combined weight.

Fail Action: For actuators with spring returns, spring fail action is available for push-down-to-open or push-down-to-close valve action. The valve action is field reversible.

For assistance in selecting the valve/actuator mounting suited to your application, consult your Emerson Process Management sales office. Dimensions for wafer-style and single-flanged valves are shown in figure 8.

Product Bulletin

51.6:8560
August 2010

8560 Valve

Table 1. Flow Coefficients⁽¹⁾

VALVE SIZE, NPS	C _v FORWARD FLOW WITH DISC WIDE OPEN (90 DEGREES ROTATION)	
	CL150	CL300
2	80.2	80.2
3	237	237
4	499	488
6	1250	1110
8	2180	2070
10	3600	3480
12	5400	5130

1. See the section titled Coefficients in this bulletin, and also Catalog 12 for a complete listing of flow coefficients.

Table 2. Construction Material Temperature Limits

COMPONENTS AND MATERIALS OF CONSTRUCTION	TEMPERATURE LIMITS	
	°C	°F
Valve Body Material		
Carbon Steel	-29 to 427	-20 to 800
CF8M	-198 to 538	-325 to 1000
CG8M	-198 to 538	-325 to 1000
Disc Material		
CF8M	-198 to 538	-325 to 1000
CG8M	-198 to 538	-325 to 1000
Shaft Material		
S20910	-198 to 538	-325 to 1000
S17400	-62 to 427	-80 to 800
Bearing Material		
PEEK / PTFE lined	-73 to 260	-100 to 500
Metal (NOVEX or Phoenix III only)	-198 to 538	-325 to 1000
Packing Material		
PTFE V-Rings	-46 to 232	-50 to 450
Graphite rings (NOVEX or Phoenix III only)	-198 to 538	-325 to 1000
Seal Ring		
PTFE (Standard) Soft Seal Ring	-46 to 232	-50 to 450
Reinforced PTFE Soft Seal Ring	-46 to 232	-50 to 450
UHMWPE Soft Seal Ring	-18 to 93	0 to 200
NOVEX Metal Seal Ring	-46 to 538	-50 to 1000
NPS 2 Metal Seal ring	-46 to 538	-50 to 1000
Phoenix III Metal Seal Ring Fluorocarbon backup ring	-40 to 232	-40 to 450
Phoenix III Fire-Tested⁽¹⁾ Metal Seal Ring Fluorocarbon backup ring (Specify metal bearings and graphite packing)	-40 to 232	-40 to 450

1. For component selection and applicable fire-tested standards and codes, consult your Emerson Process Management sales office.

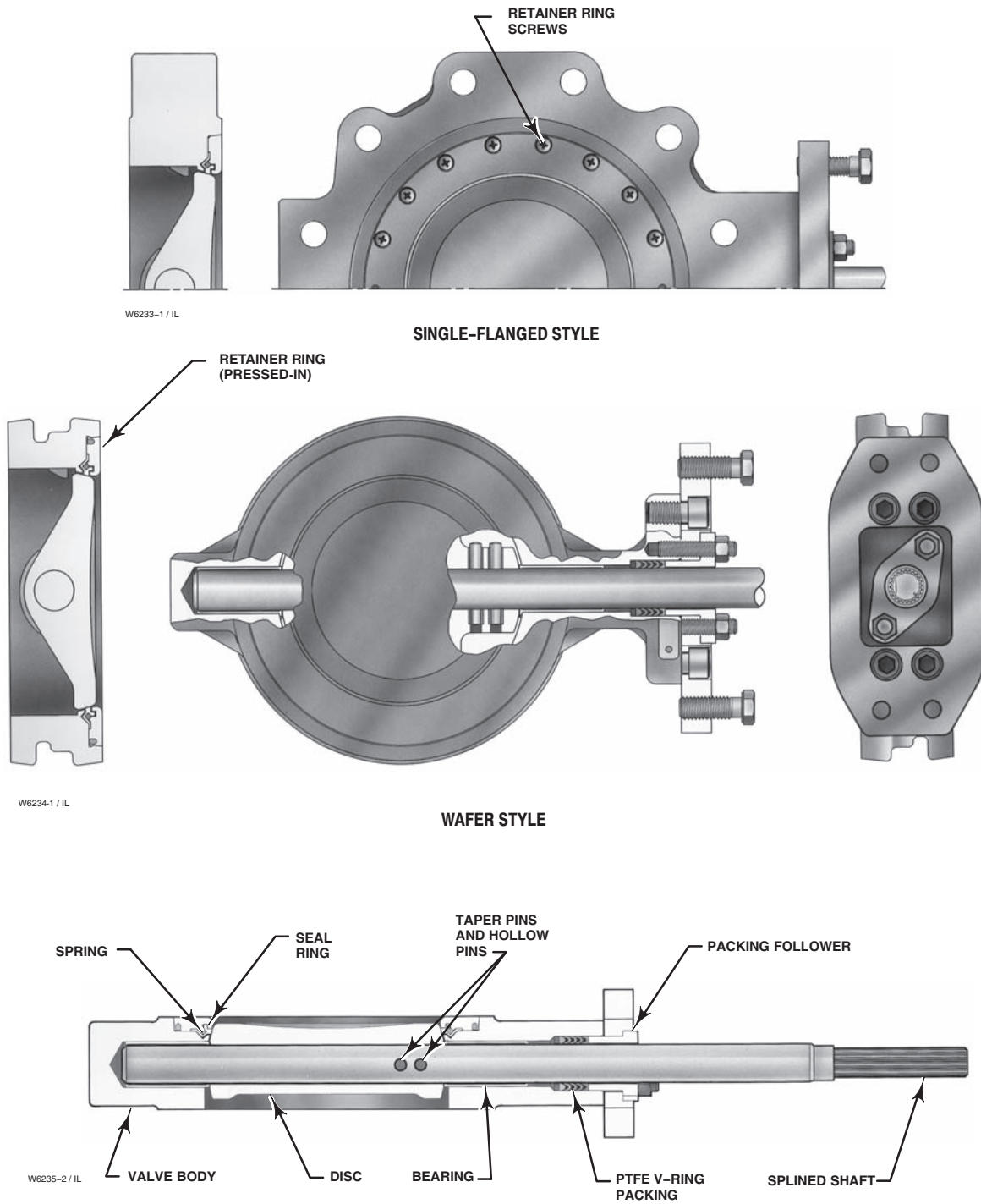
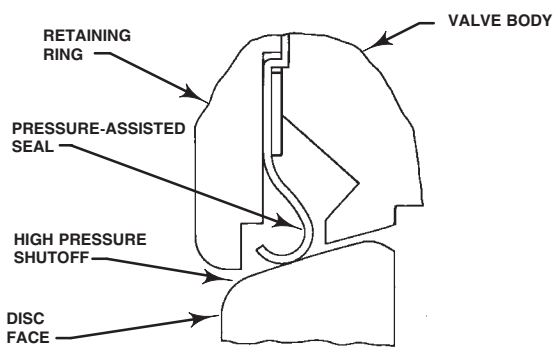
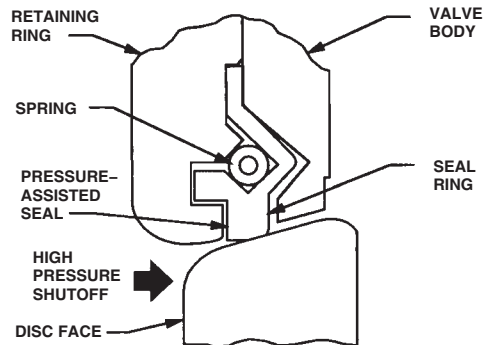

Figure 3. Typical Valve Construction



B1558-3 / IL

NPS 2 METAL SEAL



BIDIRECTIONAL SEAL
PTFE, REINFORCED PTFE, AND UHMWPE SEALS

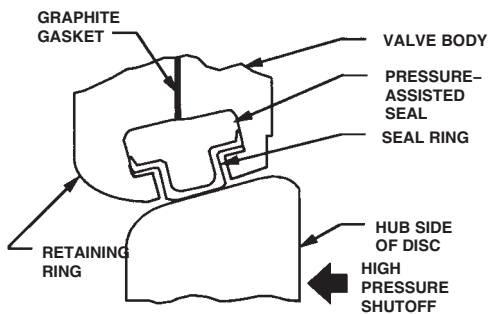

A6301-1 / IL

UNIDIRECTIONAL SEAL
NOVEX METAL SEAL

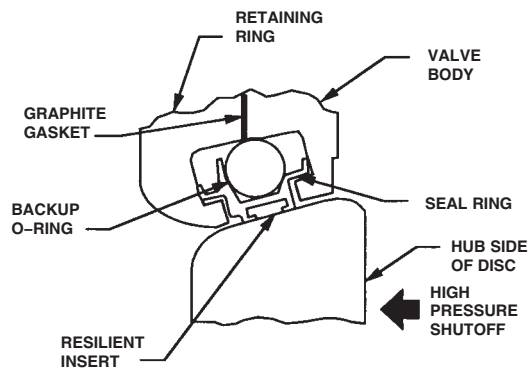

BIDIRECTIONAL SEAL
PHOENIX III METAL SEAL

Figure 4. Available Seal Configuration

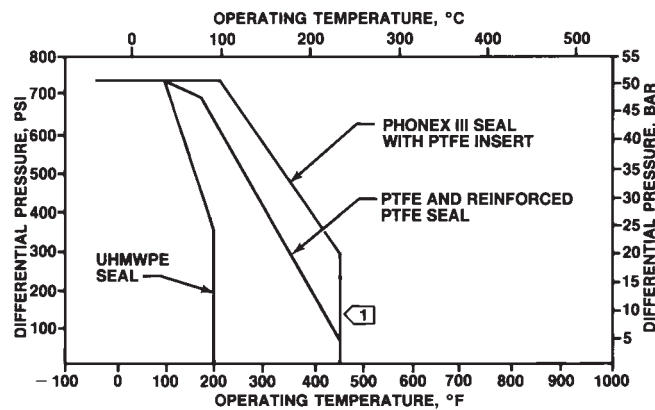

NOTE:

① TEMPERATURE LIMITATIONS DO NOT ACCOUNT FOR THE ADDITIONAL LIMITATIONS IMPOSED BY THE BACKUP RING USED WITH THIS SEAL. TO DETERMINE THE EFFECTIVE TEMPERATURE LIMITATION OF THE APPROPRIATE SEAL/BACKUP RING COMBINATION, REFER TO TABLE 2.

A6306-2 / IL

Figure 5. Maximum Pressure-Temperature Ratings

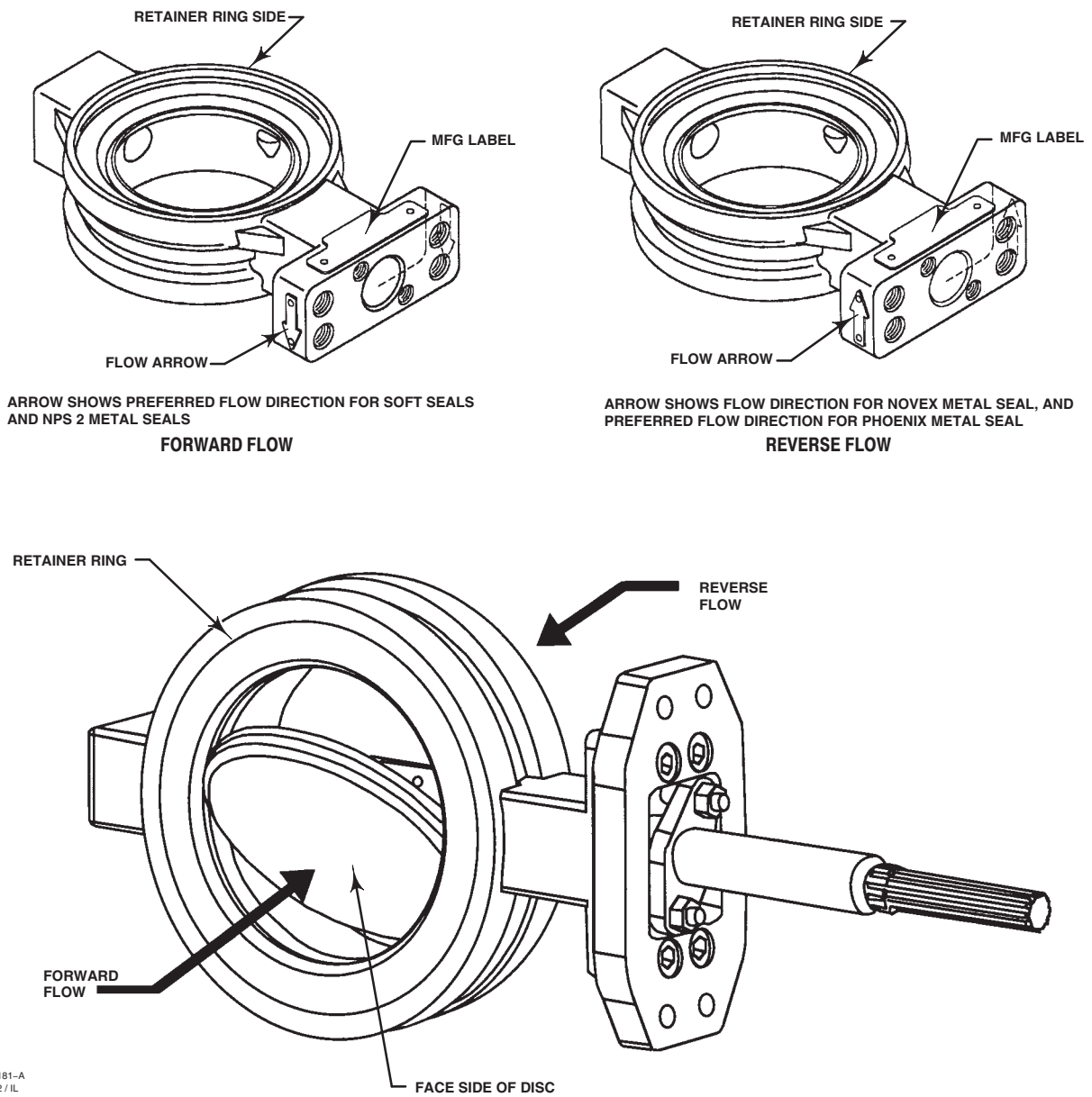

75B1181-A
A6882 / IL

Figure 6. Actuator Mounting

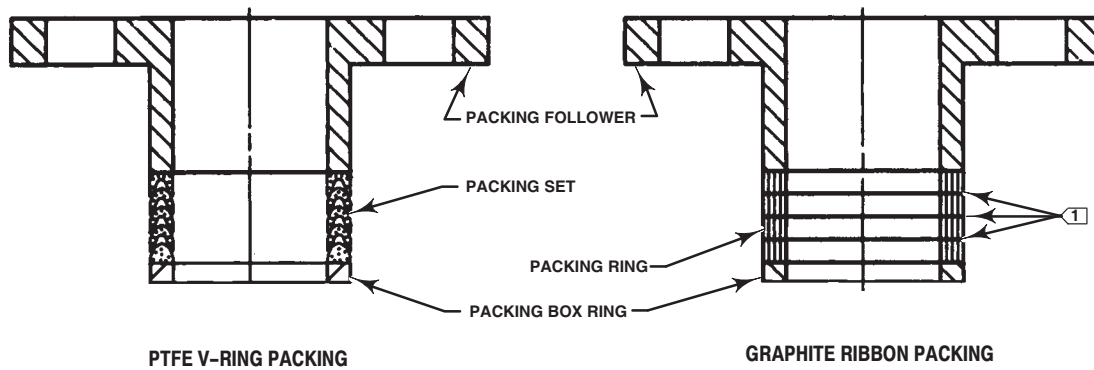

PTFE V-RING PACKING

GRAPHITE RIBBON PACKING

STANDARD PACKING

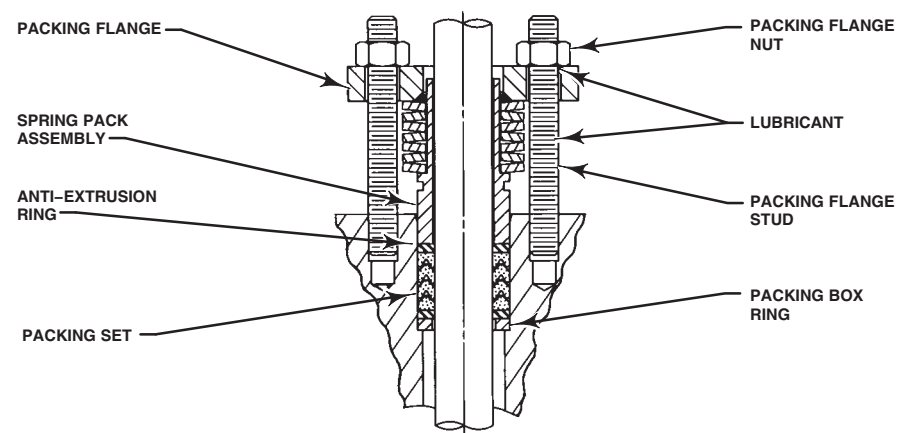

ENVIRO-SEAL PTFE PACKING SYSTEM

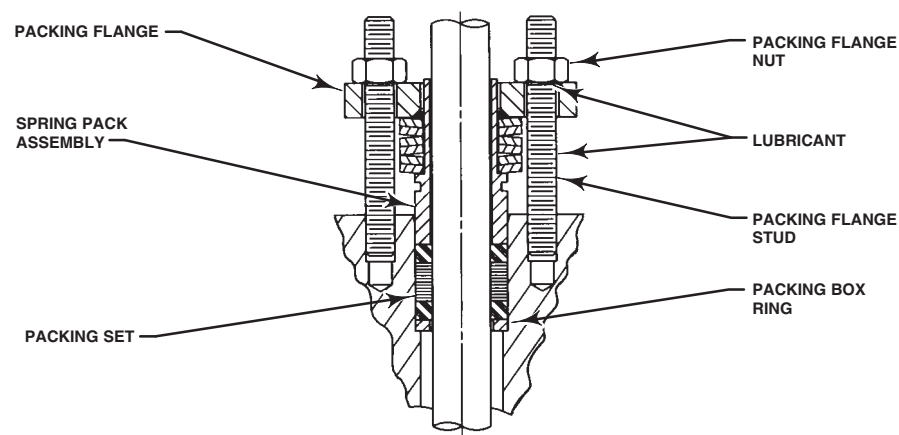

ENVIRO-SEAL GRAPHITE PACKING SYSTEM

NOTE:
1 INCLUDES ZINC WASHERS FOR GRAPHITE RIBBON PACKING ONLY
C0785'A / IL

Figure 7. Typical Packing Arrangement

8560 Valve

Table 3. CL150 Valve Dimensions

Valve Size, NPS	A	E	G		K	M ⁽²⁾	R		S ⁽¹⁾	T	U	W	Y	
			Wafer Style	Single Flange			Wafer Style	Single Flange					Single Flange Only	
mm														
2	45	188	102	---	102	---	103	---	12.7	117	---	See thread information below	---	
3	48	188	70	79	121	73	133	189	12.7	117	---		See thread information below	See thread information below
4	54	188	86	102	143	97	171	219	15.9	117	---			
6	57	214	121	129	172	146	219	273	19.1	152	32			
8	64	214	155	157	200	191	272	333	25.4	152	32			
10	71	208	186	198	254	238	330	406	31.8	235	46			
12	81	208	222	230	279	284	387	476	38.1	235	46			
Inches														
2	1.78	7.38	4.0	---	4.00	1.88	4.06	---	1/2	4.62	---	1/2-13	---	
3	1.88	7.38	2.75	3.12	4.00	2.88	5.25	7.44	1/2	4.62	---	1/2-13	5/8-11 4-holes	
4	2.12	7.38	3.38	4.00	5.62	3.81	6.75	8.62	5/8	4.62	---	1/2-13	5/8-11 8-holes	
6	2.25	8.44	4.75	5.06	6.75	5.75	8.62	10.75	3/4	6.00	1.25	1/2-13	3/4-10 8-holes	
8	2.50	8.44	6.12	6.19	7.88	7.50	10.69	13.12	1	6.00	1.25	1/2-13	3/4-10 8-holes	
10	2.81	8.19	7.31	7.81	10.00	9.38	13.00	16.00	1-1/4	9.25	1.81	5/8-11	7/8-9 12-holes	
12	3.19	8.19	8.75	9.06	11.00	11.19	15.25	18.75	1-1/2	9.25	1.81	5/8-11	7/8-9 12-holes	

1. This nominal valve shaft diameter is the shaft diameter through the packing box. Use this diameter when selecting Fisher actuators.
2. Disc chordal swing diameter at valve face. Please verify with piping.

Table 4. CL300 Valve Dimensions

Valve Size, NPS	A	E	G		K	M ⁽²⁾	R		S ⁽¹⁾	T	U	W	Y	
			Wafer Style	Single Flange			Wafer Style	Single Flange					Single Flange Only	
mm														
2	45	188	102	---	102	---	103	---	12.7	117	---	See thread information below	---	
3	48	188	89	95	137	73	132	206	15.9	117	---		See thread information below	See thread information below
4	54	214	114	121	165	97	162	238	19.1	152	32			
6	59	214	146	152	197	146	221	308	25.4	152	32			
8	73	208	175	183	235	188	276	375	31.8	235	46			
10	83	208	232	229	268	233	330	438	38.1	235	46			
12	92	365	308	308	308	278	389	508	44.5	273	51			
Inches														
2	1.78	7.38	4.00	---	4.00	1.88	4.06	---	1/2	4.62	---	1/2-13	---	
3	1.88	7.38	3.50	3.75	5.38	2.88	5.19	8.12	5/8	4.62	---	1/2-13	3/4-10 8-holes	
4	2.12	8.44	3.50	4.75	6.50	3.81	6.38	9.38	3/4	6.00	1.25	1/2-13	3/4-10 8-holes	
6	2.31	8.44	5.75	6.00	7.75	5.69	8.69	12.12	1	6.00	1.25	1/2-13	3/4-10 12-holes	
8	2.88	8.19	6.88	7.19	9.25	7.38	10.88	14.75	1-1/4	9.25	1.81	5/8-11	7/8-9 12-holes	
10	3.25	8.19	9.12	9.00	10.56	9.19	13.00	17.25	1-1/2	9.25	1.81	5/8-11	1-8 16-holes	
12	3.61	14.00	12.12	12.12	12.12	10.94	15.31	20.00	1-3/4	10.75	2.00	0.82	1-1/8-8 16-holes	

1. This nominal valve shaft diameter is the shaft diameter through the packing box. Use this diameter when selecting Fisher actuators.
2. Disc chordal swing diameter at valve face. Please verify with piping.

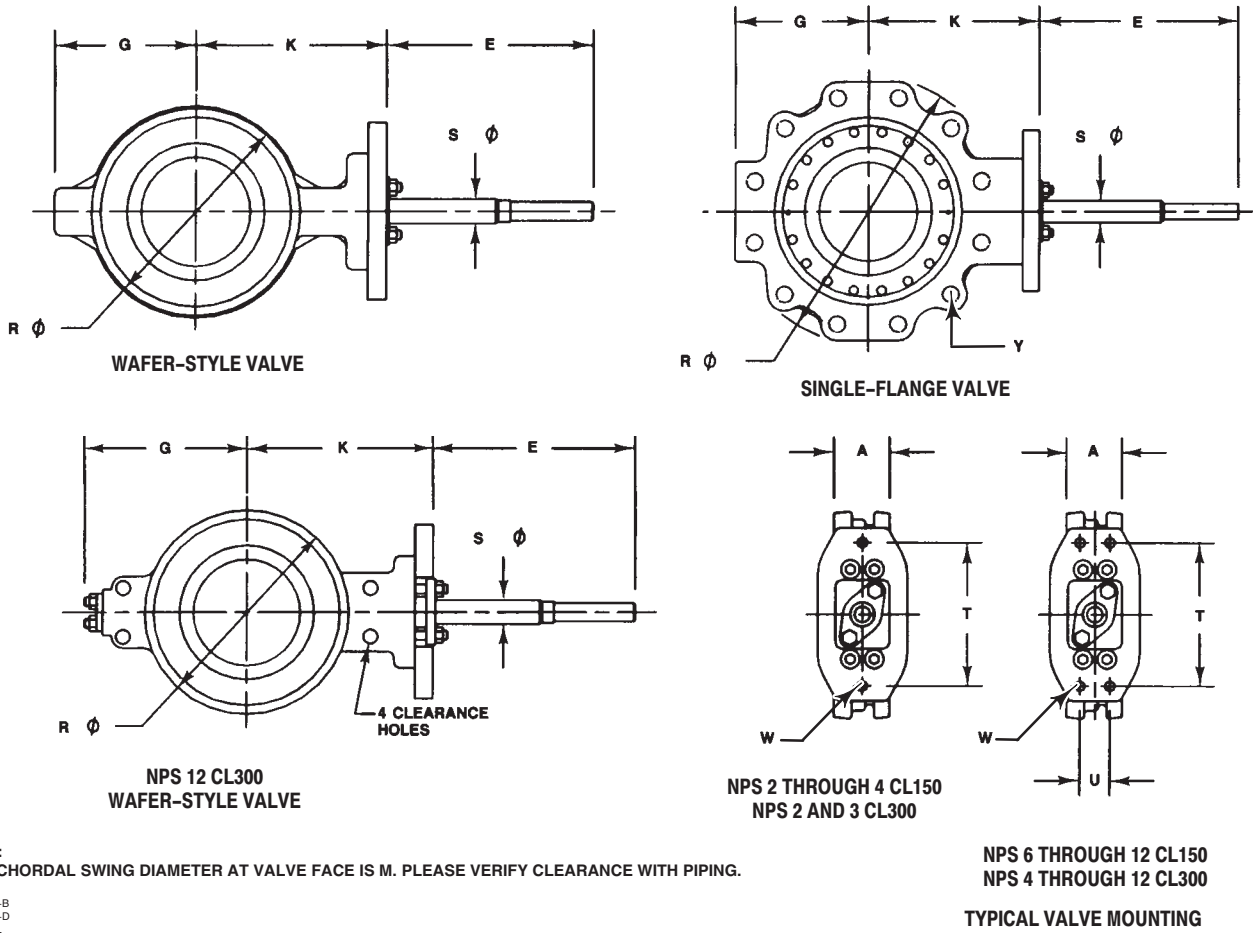

Figure 8. Typical Valve Dimensions (also see tables 3 and 4)

Coefficients

Table 5. Fisher 8560, CL150, Forward Flow

Coefficients	Valve Size, NPS	Valve Rotation, Degrees								
		10	20	30	40	50	60	70	80	90
C _v	2 ⁽¹⁾	2.25	11.4	19.9	32.6	48.1	58.9	64.0	69.8	80.2
K _v		1.95	9.86	17.2	28.2	41.6	50.9	55.4	60.4	69.4
F _L		---	0.78	0.77	0.76	0.74	0.76	0.77	0.76	0.71
X _T		0.295	0.289	0.315	0.314	0.357	0.497	0.540	0.518	0.442
F _d		0.090	0.17	0.26	0.34	0.42	0.49	0.57	0.64	0.70
C _v	3	3.21	20.8	40.5	66.7	90.1	115	150	189	237
K _v		2.78	18.0	35.0	57.7	77.9	99.5	130	163	205
F _L		0.78	0.89	0.80	0.75	0.68	0.71	0.65	0.61	0.58
X _T		0.855	0.602	0.461	0.404	0.372	0.358	0.306	0.259	0.232
F _d		0.090	0.17	0.26	0.34	0.42	0.49	0.57	0.64	0.70
C _v	4	18.2	52.6	96.7	154	199	270	351	447	499
K _v		15.7	45.5	83.6	133	172	234	304	387	432
F _L		0.80	0.85	0.79	0.73	0.74	0.69	0.64	0.61	0.53
X _T		0.474	0.474	0.500	0.416	0.407	0.326	0.271	0.220	0.196
F _d		0.090	0.17	0.26	0.34	0.42	0.49	0.57	0.64	0.70
C _v	6	34.7	109	198	321	452	664	882	1180	1250
K _v		30.0	94.3	171	278	391	574	763	1020	1080
F _L		0.85	0.83	0.75	0.71	0.71	0.67	0.65	0.61	0.55
X _T		0.389	0.552	0.528	0.438	0.424	0.331	0.278	0.206	0.203
F _d		0.090	0.17	0.26	0.34	0.42	0.49	0.57	0.64	0.70
C _v	8	60.5	190	345	560	788	1160	1540	2060	2180
K _v		52.3	164	298	484	682	1000	1330	1780	1890
F _L		0.81	0.81	0.79	0.82	0.71	0.66	0.60	0.55	0.48
X _T		0.368	0.520	0.498	0.412	0.399	0.310	0.261	0.193	0.191
F _d		0.090	0.17	0.26	0.34	0.42	0.49	0.57	0.64	0.70
C _v	10	83.3	259	463	727	1090	1670	2400	3340	3600
K _v		72.1	224	400	629	943	1440	2080	2890	3110
F _L		0.81	0.81	0.79	0.82	0.71	0.66	0.60	0.55	0.48
X _T		0.626	0.658	0.646	0.622	0.538	0.381	0.285	0.201	0.167
F _d		0.090	0.17	0.26	0.34	0.42	0.49	0.57	0.64	0.70
C _v	12	125	388	694	1090	1640	2500	3600	5010	5400
K _v		108	336	600	943	1420	2160	3110	4330	4670
F _L		0.83	0.78	0.78	0.78	0.75	0.66	0.61	0.52	0.47
X _T		0.528	0.556	0.547	0.528	0.451	0.324	0.241	0.170	0.141
F _d		0.090	0.17	0.26	0.34	0.42	0.49	0.57	0.64	0.70

1. The NPS 2 is multirated to CL150, 300 and 600.

Product Bulletin

51.6:8560
August 2010

8560 Valve

Table 6. Fisher 8560, CL150, Reverse Flow

Coefficients	Valve Size, NPS	Valve Rotation, Degrees								
		10	20	30	40	50	60	70	80	90
C _v	2 ⁽¹⁾	2.11	9.96	20.7	34.0	50.5	68.4	81.0	81.0	81.0
K _v		1.83	8.62	17.9	29.4	43.7	59.2	70.0	70.0	70.0
F _L		---	0.88	0.84	0.77	0.71	0.69	0.67	0.71	0.69
X _T		0.399	0.507	0.354	0.334	0.340	0.342	0.359	0.401	0.401
F _d		0.090	0.17	0.26	.034	0.42	0.49	0.57	0.64	0.70
C _v	3	1.79	23.0	37.0	58.8	91.9	139	192	270	259
K _v		1.55	19.9	32.0	50.9	79.5	120	166	234	224
F _L		0.70	0.81	0.73	0.76	0.75	0.66	0.60	0.50	0.54
X _T		0.449	0.455	0.395	0.417	0.423	0.313	0.256	0.188	0.203
F _d		0.090	0.17	0.26	0.34	0.42	0.49	0.57	0.64	0.70
C _v	4	17.2	50.2	87.8	146	206	285	365	465	521
K _v		14.9	43.4	75.9	126	178	247	316	402	451
F _L		0.72	0.84	0.79	0.75	0.71	0.63	0.58	0.53	0.55
X _T		0.445	0.471	0.481	0.417	0.370	0.276	0.225	0.191	0.196
F _d		0.090	0.17	0.26	0.34	0.42	0.49	0.57	0.64	0.70
C _v	6	30.6	100	173	285	424	640	893	1180	1290
K _v		26.5	86.5	150	247	367	554	772	1020	1120
F _L		0.83	0.83	0.80	0.78	0.76	0.69	0.59	0.52	0.54
X _T		0.444	0.608	0.574	0.485	0.441	0.316	0.227	0.176	0.182
F _d		0.090	0.17	0.26	0.34	0.42	0.49	0.57	0.64	0.70
C _v	8	53.6	175	303	499	743	1120	1560	2070	2260
K _v		46.4	151	262	432	643	969	1350	1790	1950
F _L		0.79	0.83	0.82	0.79	0.73	0.66	0.58	0.51	0.48
X _T		0.413	0.567	0.534	0.449	0.409	0.295	0.213	0.164	0.170
F _d		0.090	0.17	0.26	0.34	0.42	0.49	0.57	0.64	0.70
C _v	10	84.4	232	423	737	1180	1730	2560	3250	3710
K _v		73.0	200	366	638	1020	1500	2210	2810	3210
F _L		0.79	0.83	0.82	0.79	0.73	0.66	0.58	0.51	0.48
X _T		0.542	0.745	0.673	0.590	0.489	0.380	0.245	0.189	0.156
F _d		0.090	0.17	0.26	0.34	0.42	0.49	0.57	0.64	0.70
C _v	12	126	347	631	1100	1760	2590	3820	4850	5540
K _v		109	300	546	95.2	1520	2240	3300	4200	4790
F _L		0.78	0.87	0.85	0.80	0.75	0.69	0.55	0.51	0.47
X _T		0.491	0.671	0.610	0.535	0.443	0.343	0.222	0.171	0.141
F _d		0.090	0.17	0.26	0.34	0.42	0.49	0.57	0.64	0.70

1. The NPS 2 is multirated to CL150, 300 and 600.

Table 7. Fisher 8560, CL300, Forward Flow

Coefficients	Valve Size, NPS	Valve Rotation, Degrees								
		10	20	30	40	50	60	70	80	90
C _v	2 ⁽¹⁾	2.25	11.4	19.9	32.6	48.1	58.9	64.0	69.8	80.2
K _v		1.95	9.86	17.2	28.2	41.6	50.9	55.4	60.4	69.4
F _L		---	0.78	0.77	0.75	0.74	0.75	0.77	0.75	0.71
X _T		0.299	0.292	0.319	0.318	0.362	0.502	0.546	0.525	0.446
F _d		0.090	0.17	0.26	.034	0.42	0.49	0.57	0.64	0.70
C _v	3	3.21	20.8	40.5	66.7	90.1	115	150	189	237
K _v		2.78	18.0	35.0	57.7	77.9	99.5	130	163	205
F _L		0.78	0.88	0.78	0.77	0.79	0.80	0.72	0.69	0.64
X _T		0.370	0.542	0.433	0.411	0.464	0.469	0.397	0.346	0.286
F _d		0.090	0.17	0.26	0.34	0.42	0.49	0.57	0.64	0.70
C _v	4	12.9	37.4	72.9	124	174	236	318	420	488
K _v		11.2	32.4	63.1	107	151	204	275	363	422
F _L		0.81	0.86	0.79	0.73	0.72	0.71	0.65	0.60	0.54
X _T		0.455	0.499	0.416	0.395	0.410	0.363	0.292	0.235	0.210
F _d		0.090	0.17	0.26	0.34	0.42	0.49	0.57	0.64	0.70
C _v	6	39.6	120	215	340	440	598	777	1050	1100
K _v		34.3	104	186	294	381	604	672	908	952
F _L		0.80	0.77	0.71	0.68	0.71	0.68	0.62	0.60	0.56
X _T		0.420	0.433	0.434	0.369	0.360	0.299	0.282	0.214	0.205
F _d		0.090	0.17	0.26	0.34	0.42	0.49	0.57	0.64	0.70
C _v	8	73.9	224	401	634	821	1120	1450	1960	2070
K _v		63.9	194	347	548	710	969	1250	1700	1790
F _L		0.80	0.79	0.77	0.75	0.71	0.66	0.61	0.55	0.49
X _T		0.367	0.380	0.381	0.322	0.314	0.260	0.248	0.187	0.177
F _d		0.090	0.17	0.26	0.34	0.42	0.49	0.57	0.64	0.70
C _v	10	64.6	248	453	706	1070	1630	2340	3280	3480
K _v		55.9	215	392	611	926	1410	2020	2840	3010
F _L		0.80	0.79	0.77	0.75	0.71	0.66	0.61	0.55	0.49
X _T		0.464	0.565	0.562	0.544	0.455	0.335	0.255	0.179	0.159
F _d		0.090	0.17	0.26	0.34	0.42	0.49	0.57	0.64	0.70
C _v	12	95.2	365	668	1040	1580	2410	3450	4840	5130
K _v		82.3	316	578	900	1370	2080	2980	4190	4440
F _L		0.86	0.80	0.78	0.79	0.74	0.67	0.59	0.53	0.48
X _T		0.422	0.514	0.506	0.492	0.412	0.301	0.231	0.162	0.144
F _d		0.090	0.17	0.26	0.34	0.42	0.49	0.57	0.64	0.70

1. The NPS 2 is multirated to CL150, 300 and 600.

Product Bulletin

51.6:8560
August 2010

8560 Valve

Table 8. Fisher 8560, CL300, Reverse Flow

Valve Size, NPS	Coefficients	Valve Rotation, Degrees								
		10	20	30	40	50	60	70	80	90
2 ⁽¹⁾	C _v	2.11	9.96	20.7	34.0	50.5	68.4	81.0	81.0	81.0
	K _v	1.83	8.62	17.9	29.4	43.7	59.2	70.0	70.0	70.0
	F _L	---	0.88	0.84	0.77	0.71	0.69	0.67	0.71	0.69
	X _T	0.399	0.507	0.354	0.334	0.340	0.342	0.359	0.401	0.401
	F _d	0.090	0.17	0.26	0.34	0.42	0.49	0.57	0.64	0.70
3	C _v	1.79	23.0	37.0	58.8	91.9	139	192	270	259
	K _v	1.55	19.9	32.0	50.9	79.5	120	166	234	224
	F _L	0.71	0.75	0.77	0.81	0.79	0.71	0.62	0.49	0.59
	X _T	0.370	0.542	0.433	0.411	0.464	0.469	0.397	0.346	0.286
	F _d	0.090	0.17	0.26	0.34	0.42	0.49	0.57	0.64	0.70
4	C _v	12.7	35.2	61.3	105	163	242	361	463	482
	K _v	11.0	30.4	53.0	90.8	141	209	312	400	417
	F _L	0.74	0.80	0.82	0.80	0.77	0.69	0.57	0.51	0.55
	X _T	0.455	0.499	0.416	0.395	0.410	0.363	0.292	0.235	0.210
	F _d	0.090	0.17	0.26	0.34	0.42	0.49	0.57	0.64	0.70
6	C _v	38.8	106	183	294	436	605	779	976	1100
	K _v	33.6	91.7	158	254	377	523	674	844	952
	F _L	0.78	0.81	0.79	0.80	0.74	0.68	0.59	0.58	0.57
	X _T	0.420	0.433	0.434	0.369	0.360	0.299	0.282	0.214	0.205
	F _d	0.090	0.17	0.26	0.34	0.42	0.49	0.57	0.64	0.70
8	C _v	73.1	200	345	554	821	1140	1470	1840	2090
	K _v	63.2	173	298	479	710	986	1270	1590	1810
	F _L	0.80	0.83	0.83	0.80	0.74	0.66	0.58	0.50	0.48
	X _T	0.405	0.454	0.542	0.451	0.346	0.269	0.239	0.206	0.173
	F _d	0.090	0.17	0.26	0.34	0.42	0.49	0.57	0.64	0.70
10	C _v	66.2	217	399	708	1110	1690	2400	3100	3560
	K _v	57.3	188	345	612	960	1460	2080	2680	3080
	F _L	0.80	0.83	0.83	0.80	0.74	0.66	0.58	0.50	0.48
	X _T	0.505	0.714	0.672	0.557	0.465	0.339	0.243	0.187	0.155
	F _d	0.090	0.17	0.26	0.34	0.42	0.49	0.57	0.64	0.70
12	C _v	100	328	603	1070	1680	2550	3620	4690	5380
	K _v	86.5	284	522	926	1450	2210	3130	4060	4650
	F _L	0.80	0.86	0.87	0.80	0.75	0.66	0.55	0.50	0.48
	X _T	0.451	0.636	0.595	0.494	0.414	0.303	0.217	0.167	0.138
	F _d	0.090	0.17	0.26	0.34	0.42	0.49	0.57	0.64	0.70

1. The NPS 2 is multirated to CL150, 300 and 600.

Note

Neither Emerson, Emerson Process Management, nor any of their affiliated entities assumes responsibility for the selection, use, or maintenance of any product. Responsibility for the selection, use, and maintenance of any product remains with the purchaser and end user.

Fisher, FIELDVUE, and ENVIRO-SEAL are marks owned by one of the companies in the Emerson Process Management business division of Emerson Electric Co. Emerson Process Management, Emerson, and the Emerson logo are trademarks and service marks of Emerson Electric Co. All other marks are the property of their respective owners.

The contents of this publication are presented for informational purposes only, and while every effort has been made to ensure their accuracy, they are not to be construed as warranties or guarantees, express or implied, regarding the products or services described herein or their use or applicability. All sales are governed by our terms and conditions, which are available upon request. We reserve the right to modify or improve the designs or specifications of such products at any time without notice. Neither Emerson, Emerson Process Management, nor any of their affiliated entities assumes responsibility for the selection, use or maintenance of any product. Responsibility for proper selection, use, and maintenance of any product remains solely with the purchaser and end user.

Emerson Process Management

Marshalltown, Iowa 50158 USA

Sorocaba, 18087 Brazil

Chatham, Kent ME4 4QZ UK

Dubai, United Arab Emirates

Singapore 128461 Singapore

www.Fisher.com

