

Fisher® 4320 Wireless Position Monitor

The Fisher 4320 wireless position monitor is a non-contacting wireless position transmitter and limit switch. It is a rugged measurement device that provides a precise wireless feedback signal to indicate equipment position with a percent (%) of span plus on/off indication. The 4320 can be used to monitor equipment such as valves, sliding-stem regulators, displacement and float level sensors, and relief valves. It is designed to be simple to use, compact, and easily mounted.

The wireless position monitor periodically reads the position of a measured device and transmits that data over the wireless network. The transmitted data includes the percent of span value, two limit switch status indications, internal device temperatures, and power module voltage. It also checks for service and configuration instructions from host systems such as distributed control systems (DCS), asset management systems (AMS), and supervisory control and data acquisition (SCADA) systems.

The 4320 wireless position monitor can be powered by a battery sourced power module, eliminating the need to install wires. This makes it easier to design new applications or implement into retrofit locations. An external power option is also available. The elimination of levers and linkages reduces the number of mounting parts and installation complexity. Replacement and maintenance are simplified because the feedback parts stay with the measured device.

The 4320 wireless position monitor uses a high performance linkage-less feedback design that eliminates direct contact with the measured device (e.g., valve, regulator, level, louver, or other devices) eliminating physical contact and wear. *WirelessHART*® communication protocol operating at 2.4GHz is utilized and is approved for use globally.



W9634-2

Instrument calibration and commissioning is performed with a push button and liquid crystal display (LCD) interface. The interface is protected from the environment within a sealed enclosure. The interface supports multiple languages, including German, French, Italian, Spanish, Chinese, Czech, Japanese, English, Russian, Korean, and Arabic.

Designed to meet intrinsically safe and non-incendive requirements, this instrument delivers scalable functionality in a small package. Due to the energy-limiting nature of the design, this intrinsically safe device is suitable for use in all zone locations. The battery sourced power module option has no cable conduits.

The 4320 provides a percent-of-span, as well as two independent limit-switch equivalent feedback signals typically used with modulating applications.



Specifications

Available Mountings

- Quarter-turn rotary-shaft,
- Sliding-stem, or
- Linear applications

Can also be mounted on other actuators that comply with IEC 60534-6-1, IEC 60534-6-2, VDI/VDE 3845 and NAMUR mounting standards.

Input Measurement

Stem Travel (linear movement)

Minimum: 2.5 mm (0.10 inch)

Maximum: 210 mm (8.25 inches)

Shaft Rotation (rotary movement)

Minimum: 45°

Maximum: 90°

Shaft Rotation (rotary movement, arced array)

Minimum: 13°

Maximum: 30°

Measurement Output

Analog: 0-100%

Discrete: on/off switches (2)

Reference Accuracy

1% of span

Local User Interface

Liquid Crystal Display (LCD)

Two pushbuttons for navigation, setup, and calibration

Communication Protocol

HART 7

Input Communication Signal

WirelessHART communication

Initial Dynamic Variable Assignments (Default)

| Variable | Variable Name |
|-----------------|---------------------|
| Primary (PV) | Position (Fixed) |
| Secondary (SV) | Closed Limit Switch |
| Tertiary (TV) | Open Limit Switch |
| Quaternary (QV) | Temperature |

Output Communication Signal

2.4 Ghz, DSSS, *WirelessHART*

Maximum 10 dBm EIRP at 2.46 GHz,

10 mW EIRP at 2.46 GHz

Wireless Classifications

Class A digital device, complies with part 15 of the FCC Rules

Contains FCC ID: LW2RM2510

Contains IC: 2731A-RM2510

Electromagnetic Compatibility

Meets EN 61326-1 (First Edition)

Immunity—Industrial locations per Table 2 of the EN 61326-1 standard. Performance is shown in table 3.

Emissions—Class A & B. Performance is shown in table 4.

ISM equipment rating: Group 1, Class A & B

Vibration Testing

Meets or exceeds vibration levels specified in ANSI/ISA 75.13.01 1996 (2007)—4 mm peak to peak at 5 Hz to 2 Gn from 15-150 Hz and 1 Gn from 150- 2000 Hz

European Directive Information

This product complies with the following directives:

ATEX Directive (94/9/EC)

Electro Magnetic Compatibility (EMC) (2004/108/EC)

Radio and Telecommunications Terminal Equipment Directive (R&TTE) (1999/5/EC)

Refer to the Safety Instructions (D103022X012) for the Declaration of Conformity

Operating Temperature Limits⁽¹⁾

-40 to 80°C (-40 to 176°F)

LCD may not be readable below -20°C (-4°F)

Temperature Sensitivity

0.06% change per degree C

Storage Temperature Limits⁽¹⁾

Upper limit not to exceed 100°C (212°F)

Humidity Limits

10-95% Non-Condensing Relative Humidity

-continued-

Specifications (continued)

Electrical Classification

CSA (C/US)— Intrinsicly Safe
ATEX— Intrinsicly Safe
IECEX— Intrinsicly Safe
Refer to table 1 and 2 for additional information

Electrical Housing

4X & IP66

Other Classifications/Certifications

INMETRO— Brazil
NEPSI— China
Contact your Emerson Process Management sales office for classification/certification specific information

IEC 61010 Compliance

Meets Pollution Degree 2

Adjustments

Zero and Maximum Span through local interface

Dimensions

See figure 1 and 2

Weight

0.5 Kg (1.1 lbs)

Power Module

Standard
Lithium (non-rechargeable)

Power Module Limits

Standard—10 years at update rate of 16 seconds or longer with 3 additional devices communicating through it
Extended-Life—10 years at update rate of 4 seconds or longer with 3 additional devices communicating through it
Shelf life—10 years (radio off)

External Power (Optional)

12 - 28 volts DC
15 mA maximum operating current
Polarity Insensitive
Wire Size— 14-20 gauge

Update Rates

For position feedback, temperature, and power module voltage—selectable from 1 second to 1 hour; 1s, 2s, 4s, 8s, 16s, 32s, 1 to 60 minutes
Factory default is 1 minute
Note: Sample rate for position feedback is normally the same as the update rate.

Construction Material

Housing: Engineered resin

1. The temperature limits in this document and any applicable standard or code limitation for valve should not be exceeded.

Features

- **Reliable Wireless**— The *WirelessHART* self-organizing mesh network provides the high level of communication reliability required in process control.
- **Minimized Maintenance**—The sensing design provides more accurate monitoring and eliminates physical wear-out common in traditional limit switches and position transmitters. This results in less frequent maintenance, repair, and re-calibration. The standard version of this device uses a power module with expected module life meeting typical maintenance intervals.
- **Ease of Implementation**—No conduit easements or permits are required for the 4320 with the battery sourced power module, thus saving time, costs, and effort in documenting cable runs and associated design reviews. Because there is no wiring, implementation times are shortened for device installation, setup, and commissioning. Typically the reduction is from months to hours.
- **Rugged Construction**—The housing is made from engineered resin, making it a good solution for most locations, including corrosive areas.
- **Diagnostics**—Predefined device, network, and system diagnostics provide details on the health of the device and its ability to communicate. Device diagnostics include whether the device calibration

has been completed and power module health. The number of completed cycles is measured for the monitored equipment.

Note

A cycle is the change from open to closed position or vice versa. This is determined by moving past the trigger point in each direction.

- **Security**—The *WirelessHART* self-organizing mesh network includes encryption, authentication, and authorization mechanisms to provide the level of security required in process locations and by the Information Technology (IT) industry.

Firmware 2 Additions

- **Fast Updates**—Feedback on position can be transmitted as fast as 1 second.

Note

The 1420 gateway, version 4x and newer, is required for updates that are faster than 4 seconds.

- **Fast Sampling**— Sample rates can be set to as fast as 0.5 second sampling when using battery sourced power module. When using the external power option, the sampling rate is set to approximately 20 times per second.
- **Advanced Wireless Reporting**— Position feedback can be transmitted when movement occurs, reducing the amount of communication required when the position of the monitored equipment has not changed. Energy consumption is reduced with less communication.
- **External Power Support**—Optional external power module available; assembled with unit from factory.

Integration

Because the 4320 wireless position monitor operates with *WirelessHART* communications it can be used for incremental monitoring applications. This replaces manual efforts to audit or verify equipment position during normal operations, such as startup and shutdown situations, product changeover, product isolation, and sampling activities.

One implementation method can be accomplished using an overlay approach; adding wireless instrumentation on top of existing instrumentation. This preserves the existing infrastructure and enables improved information for operation, reactivity, maintenance, and safety.

A second approach is to replace older limit switches and position transmitters, either because of increased maintenance requirements or dated wiring infrastructure that has become or is believed to become an operational concern.

A third approach is to use the 4320 where feedback is not possible with standard wired options. For example, on rotating equipment, where the elimination of wires makes feedback possible.

The wireless nature of this device leads to its implementation in a wide range of systems, from programmable logic controllers (PLC), to DCS, AMS, and SCADA systems.

System integration for typical in-plant operations is available through the Smart Wireless 1420 Gateway.

Principle of Operation

The internal electronics periodically reads the position of travel and transmits that data over the wireless network. The device also checks for instructions from host systems like DCS, SCADA and asset management systems. The device “sleeps” until the next reading, enabling longer power module life. The device is still powered up in the sleep mode but operating at ultra-low power consumption levels.

Setup/Installation

Device setup is typically performed prior to installation and includes setting two network parameters. These parameters are entered using a handheld such as the 475 or 375 Field Communicator. Calibration is performed after installation and requires using the local interface to place the device at the end points of travel range. The device is then ready for commissioning and service.

Battery Sourced Power Module Life

The 4320 position monitor uses power efficient measures to keep energy consumption to a minimum. However, there is a finite amount of energy within the power module. The life expectancy of the module is affected by two things; 1) the reporting rate, and 2) the number of devices in the network that must communicate through the 4320 position monitor.

Typical on/off applications will operate effectively at one minute reporting periods.

Ordering Information

When ordering, specify:

1. Position monitor type number
2. Power source:
 - Battery sourced power module
 - External power option

3. Mounting requirements;

Feedback sensor and mounting brackets are part of the mounting

For rotary movement indicate if mounting requirements are:

- 90° NAMUR,
- 90° ISO mounting, or
- 30° for special applications

For linear movement, indicate travel length:

- 7 mm (1/4 inch)
- 19 mm (3/4 inch),
- 25 mm (1 inch),
- 38 mm (1-1/2 inch),
- 50 mm (2 inch),
- 100 mm (4 inch), or
- 210 mm (8-1/4 inch) strokes

Note

As a general rule, do not use less than 50% of the magnet assembly for full travel measurement. Performance will decrease as the assembly is increasingly subranged.

Contact your Emerson Process Management sales office if longer travel lengths are required.

Note

Contact your Emerson Process Management sales office if mounting on non-Emerson valves is required.

Figure 1. Dimensions

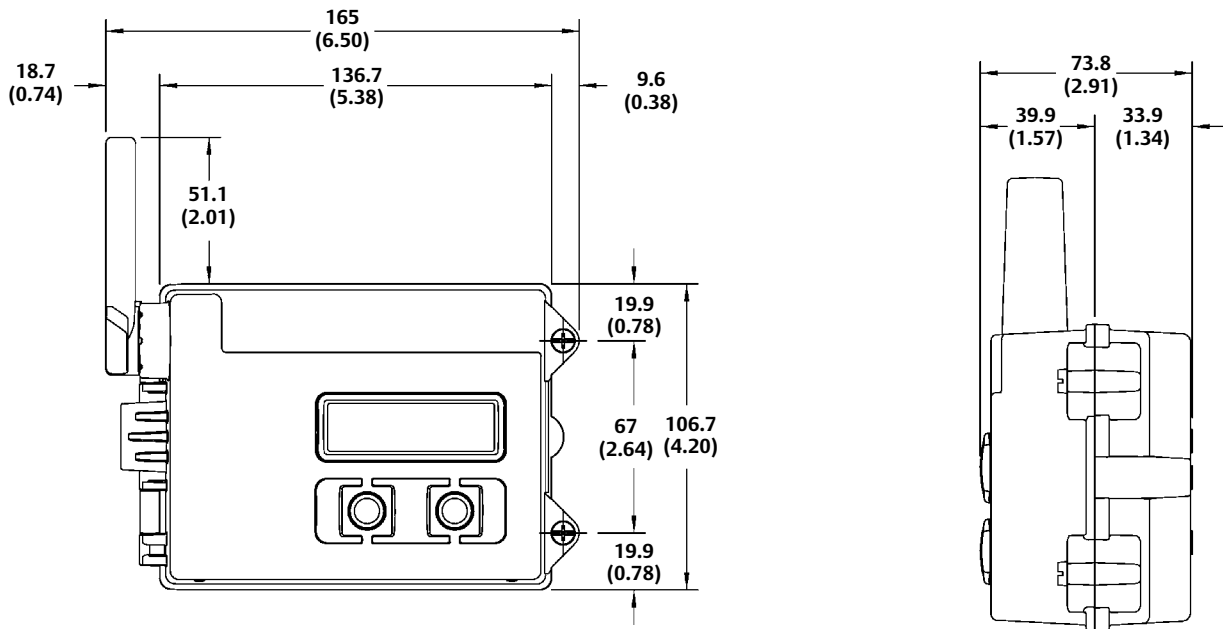

ANTENNA SHOWN VERTICAL

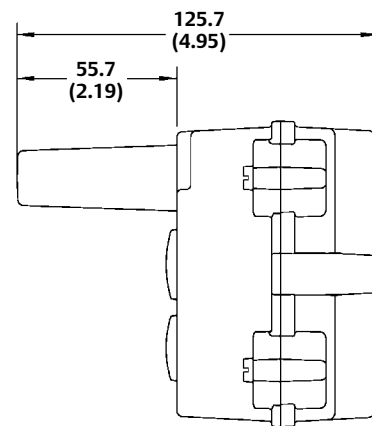
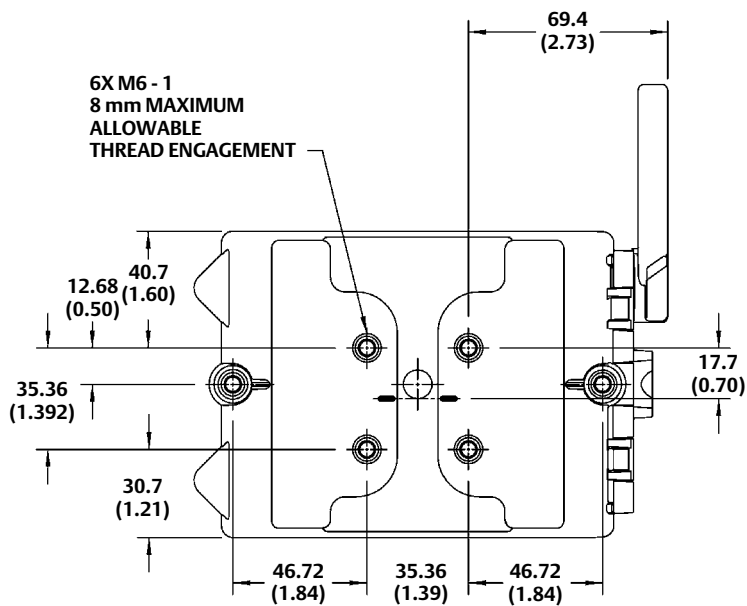

ANTENNA SHOWN HORIZONTAL

mm
(INCH)

Figure 2. Dimensions—External Power Option

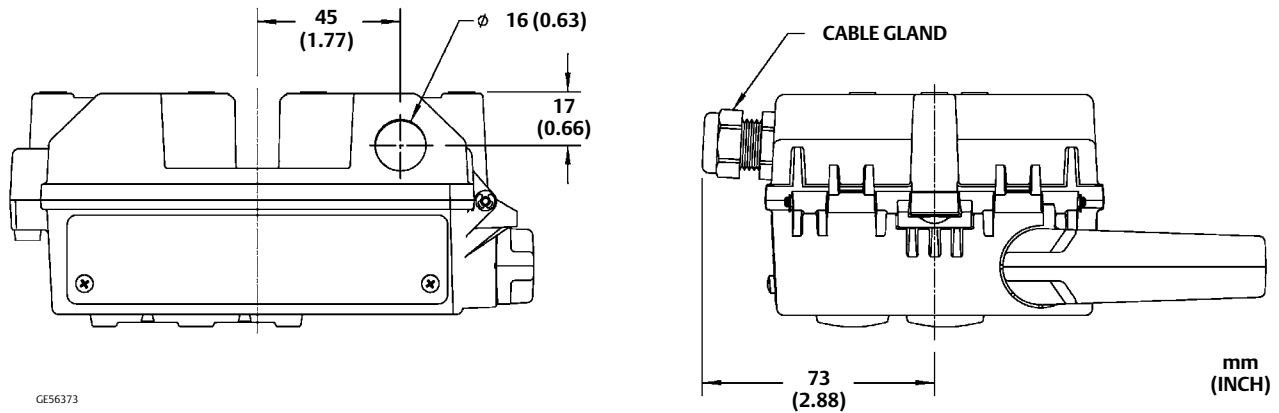

CE56373

Table 1. Hazardous Area Classifications—CSA (C/US) (Canada and United States)

| Certification Body | Certification Obtained | Entity Rating | | Temperature Code | Enclosure Rating |
|--------------------|---|---|---|--|------------------|
| CSA | Ex ia Intrinsically Safe CL I, Div I, GP ABCD T3/T4/T5 Ex ia IIC T3/T4/T5 Class I Zone 0 AEx ia IIC T3/T4/T5 | HART® Terminals WP1/WP2 | | Battery Sourced Power Module: T3(Tamb ≤ 80°C) T4(Tamb ≤ 75°C) T5(Tamb ≤ 40°C) | 4X & IP66 |
| | | Vmax (Ui) = 6.1V Imax (Ii) = 5mA Ci = 2.5nF Li = 0mH | Voc (Uo) = 5.9V Isc (Io) = 14mA Ca (Co) = 42nF La (Lo) = 150mH | | |
| | | J5 Power Terminal | | | |
| | | Vmax (Ui) = 28VDC Imax (Ii) = 130mA Pi = 1W Ci < 100pF Li < 300μH | | External Power Option: T5(Tamb ≤ 80°C) | |

Table 2. Hazardous Area Classifications—ATEX and IECEx

| Certification | Certification Obtained | Entity Rating | | Temperature Code | Enclosure Rating |
|---------------|---|---|--|--|------------------|
| ATEX IECEx | Intrinsically Safe Ex ia IIC T3/T4/T5 Ga | HART Terminals WP1/WP2 | | Battery Sourced Power Module: T3(Tamb ≤ 80°C) T4(Tamb ≤ 75°C) T5(Tamb ≤ 40°C) | 4X & IP66 |
| | | Ui = 6.1V Ii = 5mA Pi = 30.5mW Ci = 2.5nF Li = 0mH | Uo = 5.9V Io = 14mA Po = 20.7mW Co = 42nF Lo = 150mH | | |
| | | J5 Power Terminal | | | |
| | | Vmax (Ui) = 28VDC Imax (Ii) = 130mA Pi = 1W Ci < 100pF Li < 300μH | | External Power Option: T5(Tamb ≤ 80°C) | |

Table 3. EMC Summary Results—Immunity

| Port | Phenomenon | Basic Standard | Test Level | Performance Criteria ⁽¹⁾ |
|-------------------------|--------------------------------------|----------------|---|-------------------------------------|
| Enclosure | Electrostatic discharge (ESD) | IEC 61000-4-2 | 6 kV contact 8 kV air | (2) |
| | Radiated EM field | IEC 61000-4-3 | 80 to 1000 MHz @ 10 V/m with 1 kHz AM at 80% 1400 to 2000 MHz @ 10 V/m with 1 kHz AM at 80% Battery Sourced Power Module 2000 to 2700 MHz @ 3 V/m with 1 kHz AM at 80% External Power Option 2000 to 2700 MHz @ 1 V/m with 1 kHz AM at 80% | A |
| | Rated power frequency magnetic field | IEC 61000-4-8 | 100 A/m @ 50 Hz & 60 Hz | A |
| DC Power ⁽³⁾ | Burst | IEC 61000-4-4 | 2 kV (5/50 ns, 5 kHz) | A |
| | Surge | IEC 61000-4-5 | 1 kV line to line / 2 kV line to ground | A |
| | Conducted RF | IEC 61000-4-6 | 10 Vrms (150 kHz to 80 MHz) | A |

Performance criteria: +/- 2% of effect
 1. A = No degradation during testing. B = Temporary degradation during testing, but is self-recovering.
 2. Battery Sourced Power Module = B ; External Power Option = A
 3. External Power Option only.

Table 4. EMC Summary Results—Emissions

| Port | Frequency Range (MHz) | Basic Standard | Emissions Level | Given Rating |
|-----------------------------------|-----------------------|----------------|--|--------------|
| Enclosure | 30 to 230 | EN 55011 | Group 1 Class A: 40 dB (µV/m) measured at 10 m distance Group 1 Class B: 30 dB (µV/m) measured at 10 m distance | Class A & B |
| | 230 to 1000 | | Group 1 Class A: 47 dB (µV/m) measured at 10 m distance Group 1 Class B: 37 dB (µV/m) measured at 10 m distance | Class A & B |
| | 1000 to 3000 | EN 55022 | Group 1 Class B 50 dB (µV/m) measured at 3 m distance, peak limit not to exceed 70 dB (µV/m) | Class A & B |
| | 3000 to 6000 | | Group 1 Class B 54 dB (µV/m) measured at 3 m distance, peak limit not to exceed 74 dB (µV/m) | Class A & B |
| External Power Option Only | | | | |
| Enclosure | 0.15 to 0.50 | EN 55011 | Group 1 Class B 56-46 dB (µV) ⁽¹⁾ , peak limit not to exceed 66 dB (µV) | Class A |
| | 0.50 to 5 | | Group 1 Class B 46 dB (µV), peak limit not to exceed 56 dB (µV) | Class A |
| | 5 to 30 | | Group 1 Class B 50 dB (µV), peak limit not to exceed 60 dB (µV) | Class A |

NOTES:
 The 4320 is considered as a Group 1 device.
 Industrial, Scientific, and Medical (ISM) radio frequency (RF) equipment is rated according to its Group and Class as follows:
 Group I - Equipment in which there is intentionally generated and/or used conductively coupled radio-frequency energy which is necessary for the internal functioning of the equipment itself.
 Group II - Equipment in which radio-frequency energy is intentionally generated and/or used in the form of electromagnetic radiation for the treatment of material, and EDM and arc welding equipment.
 Class A - Equipment suitable for use in industrial and commercial environments
 Class B - Equipment suitable for use in domestic environments
 1. Decreasing linearly with logarithm of frequency.

Neither Emerson, Emerson Process Management, nor any of their affiliated entities assumes responsibility for the selection, use or maintenance of any product. Responsibility for proper selection, use, and maintenance of any product remains solely with the purchaser and end user.

Fisher is a mark owned by one of the companies in the Emerson Process Management business unit of Emerson Electric Co. Emerson Process Management, Emerson, and the Emerson logo are trademarks and service marks of Emerson Electric Co. HART and WirelessHART are marks owned by the HART Communication Foundation. All other marks are the property of their respective owners.

The contents of this publication are presented for informational purposes only, and while every effort has been made to ensure their accuracy, they are not to be construed as warranties or guarantees, express or implied, regarding the products or services described herein or their use or applicability. All sales are governed by our terms and conditions, which are available upon request. We reserve the right to modify or improve the designs or specifications of such products at any time without notice.

Emerson Process Management
 Marshalltown, Iowa 50158 USA
 Sorocaba, 18087 Brazil
 Chatham, Kent ME4 4QZ UK
 Dubai, United Arab Emirates
 Singapore 128461 Singapore

www.Fisher.com

