

Fisher® YD and YS Control Valves

Fisher YD (figure 1) and YS three-way cage-guided valves are designed for throttling or flow-switching (on-off) service, and are available in the following constructions:

YD (Balanced)—For general converging (flow-mixing) and diverging (flow-splitting) service. Available in standard and high-temperature versions (see figure 2).

YS (Unbalanced)—For general converging service. When used in diverging service, recommended for on-off applications only (see figure 2).

The Fisher YD and YS product lines are available for a wide range of applications, including sulfide and chloride stress-cracking environments common to the oil and gas production industries. To discuss available constructions, contact your Emerson Process Management sales office and include the applicable codes and standards required for these environments.

Common easy-e™ valve characteristics include the following:

- S31600 stainless steel packing box parts are standard (including packing flange, studs, and nuts)



W7593

Figure 1. Fisher YD Valve with 667 Actuator

Contents

Features	2
Flow Directions	3
ENVIRO-SEAL™, HIGH-SEAL Packing Systems .	3
Installation	17
Tables	
Travel, Port, and Gasket Loading	
Pressure Drop Information	5
Trim Materials	5
Materials and Temperature Limits	
for Other Parts	6
Valve Body-Trim Temperature	
Capabilities	7
Maximum Allowable YD Shutoff Pressure	
Drops with 657 and 667 Actuators	9

Maximum Allowable YS	
(Converging Service) Shutoff Pressure	
Drops with 657 and 667 Actuators ...	12
Maximum Allowable YS	
(Diverging Service) Shutoff Pressure	
Drops with 657 and 667 Actuators	
(ON-OFF) application only--	
No throttling service	15
Bonnet Selection Guidelines	19
Dimensions	18
Ordering Information	18
Coefficients	20
Specifications	28
ENVIRO-SEAL Packing System	
Specifications	30



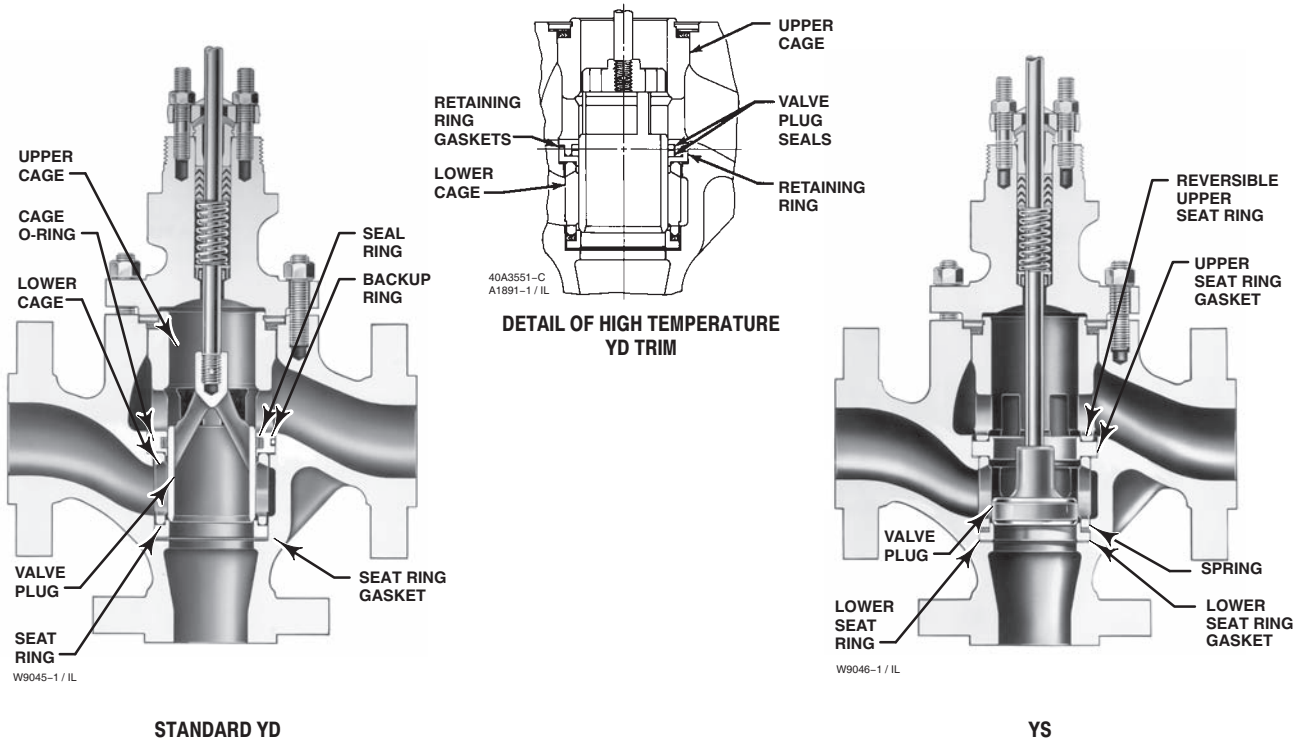

Figure 2. Construction Details

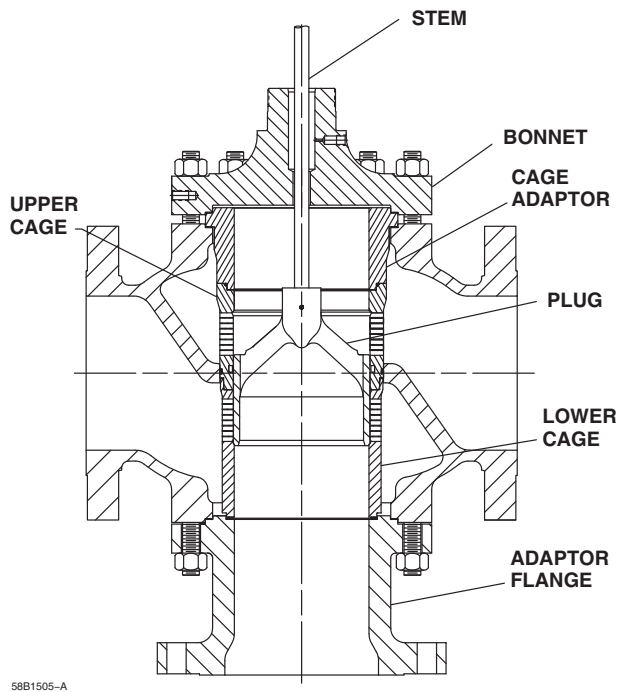

Figure 3. Construction Details - NPS 8 YD

Features

- **Economy**—Balanced valve plug construction in the YD permits use of smaller, lower-cost actuators. A single one-piece valve accommodates both trim designs and uses Fisher easy-e bonnets, gaskets, and packing, thus cutting spare part inventory costs.

- **Application Flexibility**—Multipurpose capability results from a valve designed specifically for three-way control. A variety of valve sizes, end connections, port diameters, and trim materials provides design versatility for your control needs.

- **Excellent Sealing Capabilities**—The ENVIRO-SEAL packing system option is available. This packing system provides excellent sealing, guiding, and loading force transmission. The improved sealing of the ENVIRO-SEAL system can help control emissions to below the EPA (Environmental Protection Agency) limit of 100 ppm (parts per million) from valves. The ENVIRO-SEAL packing systems feature PTFE, Graphite ULF, or Duplex packing with live-loading for reduced packing maintenance.

Product Bulletin

51.1:YD
April 2010

YD and YS Valves

- **Long Trim Life**—Hardened trim materials provide excellent wear resistance.
- **Easy Maintenance**—Cage-type construction simplifies inspection and removal of parts.
- **Valve Plug Stability**—Rugged cage guiding provides high valve plug stability, which reduces vibration and mechanical noise.

Flow Directions

YD (Common Port on Bottom) see figure 6

- **Plug Down, Left-Hand Port Closed**—Flow in converging service is from right to bottom port and in diverging service is from bottom to right port.
- **Plug Up, Right-Hand Port Closed**—Flow in converging service is from left to bottom port and in diverging service is from bottom to left port.
- **Intermediate Plug Positions**—Flow in converging service is from both left and right ports to bottom port, with capacities in proportion to plug travel. Flow in diverging service is from bottom port to both left and right ports, with capacities split in proportion to plug travel.

YS (Common Port on Left) see figure 6

- **Plug Down, Bottom Port Closed**—Flow in converging service is from right to left port and in diverging service is from left to right port.
- **Plug Up, Right-Hand Port Closed**—Flow in converging service is from bottom to left port and in diverging service is from left to bottom port.
- **Intermediate Plug Positions**—Flow in converging service is from both bottom and right ports to left port, with capacities in proportion to plug travel.



WS852-1 / IL

Figure 4. Cutaway of ENVIRO-SEAL Bellows Seal Bonnet and Internal Shroud, Showing Bellows

ENVIRO-SEAL, HIGH-SEAL Packing Systems

ENVIRO-SEAL and HIGH-SEAL packing systems offer excellent sealing capabilities. These systems easily install in your existing valves or can be purchased with new valves. These systems help you seal your process to conserve valuable process fluid. The long operational life and reliability of these systems also reduce your maintenance costs and downtime.

For applications requiring compliance with environmental protection regulations, the unique ENVIRO-SEAL packing system (figure 5) and, for hazardous service, the ENVIRO-SEAL bellows seal system (figure 4) are offered. The emission control packing system keeps emission concentrations below the EPA 100 ppm requirement.

For an excellent stem seal in applications that are not environmentally sensitive, the HIGH-SEAL Graphite ULF packing system (figure 5) is offered. The HIGH-SEAL packing system provides excellent sealing at pressure/temperature ratings beyond ENVIRO-SEAL limits. ENVIRO-SEAL systems may also be applied for excellent stem sealing in higher pressure/temperature applications not requiring EPA compliance.

ENVIRO-SEAL packing systems, available with PTFE, Graphite ULF, or Duplex packing, and the HIGH-SEAL Graphite ULF packing system feature live-loading and unique packing-ring arrangements for long-term, consistent sealing performance.

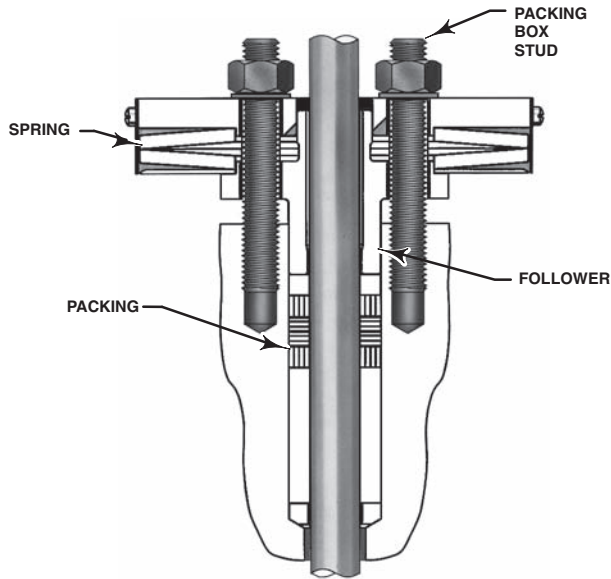

W8533-1

TYPICAL HIGH-SEAL PACKING SYSTEM WITH GRAPHITE ULF PACKING

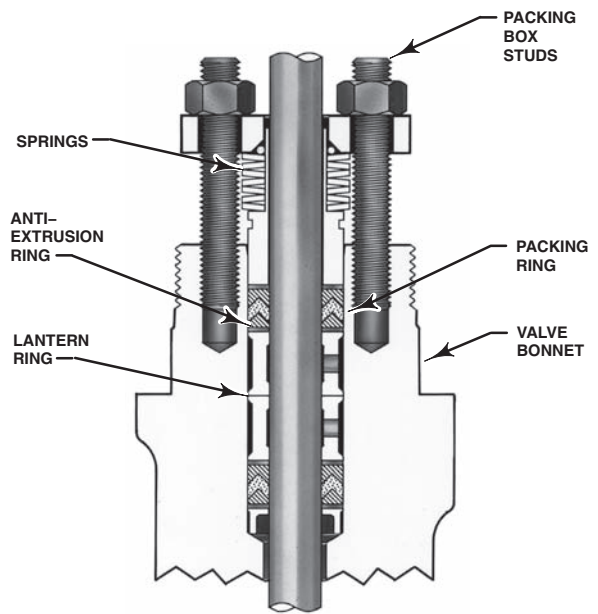

W5803-3 / IL

TYPICAL ENVIRO-SEAL PACKING SYSTEM WITH PTFE PACKING

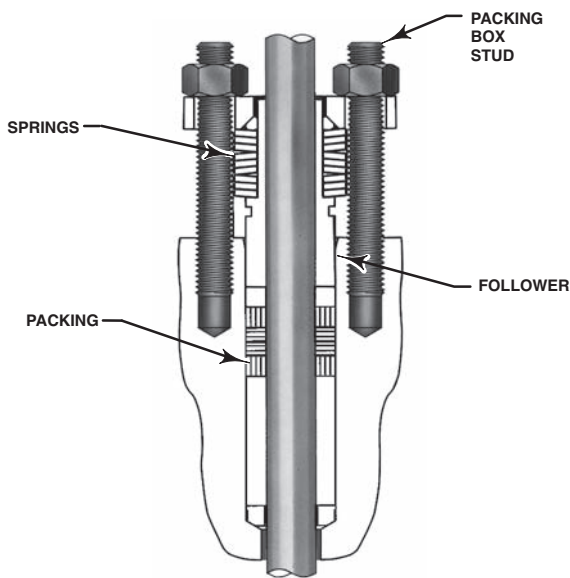

W8532-1

TYPICAL ENVIRO-SEAL PACKING SYSTEM WITH GRAPHITE ULF PACKING

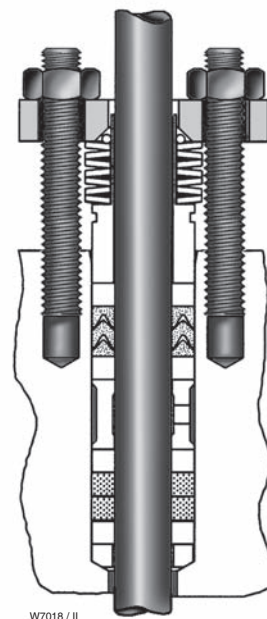

W7018 / IL

TYPICAL ENVIRO-SEAL PACKING SYSTEM WITH DUPLEX PACKING

Figure 5. ENVIRO-SEAL and HIGH-SEAL Packing Systems

Product Bulletin

51.1:YD
April 2010

YD and YS Valves

Table 1. Travel, Port, and Gasket Loading Pressure Drop Information

VALVE SIZE, NPS	MAXIMUM RATED TRAVEL		SEAT RING PORT DIAMETER		PRESSURE DROP LIMIT DUE TO GASKET LOADING			
	mm	Inches	mm	Inches	YS		YD ⁽¹⁾	
					bar	psig	bar	psig
1/2, 3/4, 1, 1-1/2	19	0.75	33.3	1.3125	41.4	600	103.4	1500
2, 2-1/2	29	1.125	58.7	2.3125	31.7	460		
3	38	1.5	87.3	3.4375	37.9	550		
4	51	2	111.1	4.375	38.6	560		
6	51	2	177.8	7	52.4	760		
8 ⁽²⁾	57.2	2.25	177.8	7	---	---		

1. For standard YD only. For high temperature YD, consult your Emerson Process Management sales office.
2. NPS 8 only available in YD construction.

Table 2. Trim Materials

PART	MATERIAL			
		Trim 1	Trim 2 ⁽¹⁾	Trim 2A
Valve Plug	YD	CB7Cu-1 (17-4PH SST)	CF8M (316 SST)	CF8M/CoCr-A
	YS	S41600 (416 SST)	S31600 (316 SST)	CF8M/CoCr-A
Upper Cage and Lower Cage		CB7Cu-1	CF8M, ENC	CF8M, ENC
Upper Cage Retaining Ring (High-Temperature YD Only)		S41600	CF8M	CF8M
Upper Seat Ring (YS Only) and Lower Seat Ring		S41600	S31600	S31600/CoCr-A

1. Standard trim for stainless steel valves.

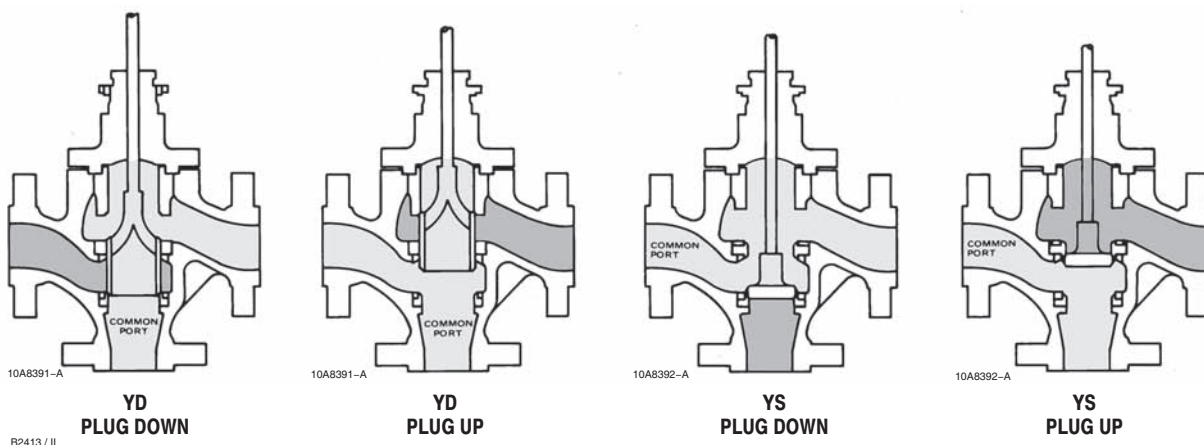

Figure 6. Flow Directions

Table 3. Materials and Temperature Limits for Other Parts

PART			MATERIAL		IN-BODY PROCESS TEMPERATURE				
					°C		°F		
					Min	Max	Min	Max	
Body-to-bonnet bolting. See table 4 for NACE bolting materials and temperatures	Cast iron body		Cap screws	Steel SAE Grade 5	-29	232	-20	450	
	WCC body		Studs	Steel SA-193-B7	-29	427 ⁽¹⁾	-20	800 ⁽¹⁾	
			Nuts	Steel SA-194-2H					
	316 stainless steel (CF8M)		Studs	Steel SA-193-B7 (std)	-48	427 ⁽¹⁾	-55	800 ⁽¹⁾	
			Nuts	Steel SA-194-2H (std)					
			Studs	304 stainless steel SA-320-B8	-198	38	-325	100	
			Nuts	304 stainless steel SA-194-8					
			Studs	316 stainless steel SA-193-B8M (strain-hardened)	-198 ⁽²⁾	427 ⁽¹⁾	-325 ⁽²⁾	800 ⁽¹⁾	
			Nuts	316 stainless steel SA-194-8M					
	Studs	316 stainless steel SA-194-B8M (annealed)	-198 ⁽²⁾		-325 ⁽²⁾	These mat'l's not limiting factors			
	Nuts	316 stainless steel SA-194-8M							
	LCC body		Studs	Steel SA-193-B7	-46	343 ⁽¹⁾	-50	650 ⁽¹⁾	
Nuts			Steel SA-194-2H						
Valve plug stem and pin			S31600 (316 SST)		-254	... ⁽¹⁾	-425	... ⁽¹⁾	
Plug-cage seals (YD only)	Standard YD	Cage O-ring and backup ring	Ethylene propylene ⁽²⁾		-40	232	-40	450	
			Nitrile ⁽³⁾	With hydrocarbons, air		-34	71	-30	160
				With other process fluids		-34	82	-30	180
			Fluorocarbon ⁽⁴⁾		-18	204	0	400	
	High-temperature YD	Seal ring	Carbon-filled PTFE	-73	232	-100	450		
		Valve plug seals	Graphite	-254	... ⁽¹⁾	-425	... ⁽¹⁾		
	Retaining ring gaskets	FGM Graphite/S31600	-254	... ⁽¹⁾	-425	... ⁽¹⁾			
Bonnet gasket			FGM Graphite/S31600		-254	... ⁽¹⁾	-425	... ⁽¹⁾	
Retaining ring gaskets (High-temperature YD only)			FGM Graphite/S31600		-254	... ⁽¹⁾	-425	... ⁽¹⁾	
Spiral wound gaskets			N06600/graphite FGM-standard		-198	... ⁽¹⁾	-325	... ⁽¹⁾	
Spiral wound spring	NPS 1 to 3		N06600/graphite FGM		-198	... ⁽¹⁾	-325	... ⁽¹⁾	
	NPS 4 to 8		N06600		-198	... ⁽¹⁾	-325	... ⁽¹⁾	
Packing (temperatures calculated for standard bonnet)	Standard		PTFE V-ring		-40	232	-40	450	
	Optional		PTFE/composition		-73	232	-100	450	
			Graphite ribbon/filament		-254	... ⁽¹⁾	-425	... ⁽¹⁾	
Packing flange, studs, and nuts			316 SST		-254	... ⁽¹⁾	-425	... ⁽¹⁾	
Packing box ring			316 SST		-254	... ⁽¹⁾	-425	... ⁽¹⁾	
All other metal packing box parts			316 SST		-254	... ⁽¹⁾	-425	... ⁽¹⁾	

1. Maximum temperature of this part not a limiting factor.
 2. Has excellent moisture resistance with hot water and steam and may be used with most fire-resistant hydraulic oils, but cannot be used with petroleum-based fluids and other hydrocarbons.
 3. General-purpose material with good resistance to petroleum-based lubricating oils, gasoline, and other hydrocarbons. Not for use with fire-resistant hydraulic oils.
 4. For high-temperature air, hydrocarbons, and certain other chemicals and solvents, but cannot be used with ammonia, steam, or hot water.

Product Bulletin

51.1:YD
April 2010

YD and YS Valves

Table 4. Bolting Materials and Temperature Limits for Bolting Compliance with NACE Specification MR0175-2002, MR0157/ISO 15156, and MR0103

VALVE BODY MATERIAL		BOLTING MATERIAL		TEMPERATURE CAPABILITIES			
				°C		°F	
				Min	Max	Min	Max
NACE MR0175-2002, MR0157/ISO 15156, and MR0103 (non-exposed bolting) (Standard)							
WCC and CF8M (316 SST)	Studs	Steel SA-193-B7		-48 ⁽³⁾	427	-55 ⁽³⁾	800
	Nuts	Steel SA-194-2H					
NACE MR0175-2002 (exposed bolting) (Optional) No Derating of Valve Required							
WCC and CF8M	Studs	Steel SA-564-630 (H1150 dbI ⁽¹⁾)		-46 ⁽³⁾	343	-50 ⁽³⁾	650
	Nuts	Steel SA-194-2HM					
NACE MR0175-2002, MR0157/ISO 15156, and MR0103 (exposed bolting) (Optional) Requires Derating of Valve⁽²⁾ When These Body-to-Body Bolting Materials are Used							
WCC and CF8M	Studs	Steel SA-193-B7M		-48 ⁽³⁾	427	-55 ⁽³⁾	800
	Nuts	Steel SA-194-2HM					

1. Special heat treating required.
2. Derating is not required for CL300 valves. Derating may be required for valves rated at CL600. Contact your Emerson Process Management sales office for assistance in determining the derating of valves when these body-to-bonnet bolting materials are used.
3. WCC is limited to -29°C (-20°F).

Table 5. Valve Body-Trim Temperature Capabilities⁽¹⁾

VALVE BODY MATERIAL	TRIM NUMBER FROM TABLE 2	TEMPERATURE ⁽²⁾					
		Minimum		Maximum			
		°C	°F	Standard YD		YS and High-Temperature YD	
				°C (°F)		°C (°F)	
Cast Iron ⁽³⁾	1	-73	-100	232 (450)		232 (450)	
	2 ⁽²⁾ and 2A	-73	-100	NPS 1-1/2 to 3: 232 (450) NPS 4 to 6: 177 (350)		232 (450)	
WCC Steel and WC9 Chrome Moly Steel	1	-29	-20	NPS 1/2 to 1-1/2: 427 (800) ⁽⁴⁾ NPS 2 and 2-1/2: 371 (700) ⁽⁴⁾ NPS 3: 316 (600) ⁽⁴⁾ NPS 4 and 6: 260 (500) ⁽⁴⁾		427 (800)	
	2 ⁽²⁾	-29	-20	NPS 1/2 to 1-1/2: 316 (600) ⁽⁴⁾ NPS 2 and 2-1/2: 232 (450) NPS 3: 204 (400) NPS 4 and 6: 149 (300)		316 (600)	
	2A	-29	-20	NPS 1/2 to 1-1/2: 343 (650) ⁽⁴⁾ NPS 2 and 2-1/2: 232 (450) NPS 3: 204 (400) NPS 4 and 6: 149 (300)		343 (650)	
CF8M (316 SST)	2 ⁽²⁾	-254	-425	316 (600) ⁽⁴⁾		316 (600)	
	2A	-198 ⁽⁵⁾	-325 ⁽⁵⁾	343 (650) ⁽⁴⁾		343 (650)	
NPS 8 YD (WCC)	1	-29	-20	232 (450)		427 (800) ⁽⁶⁾	
NPS 8 YD (CF8M)	2 ⁽²⁾	-198	-325	232 (450)		316 (600) ⁽⁶⁾	
	2A	-198	-325	232 (450)		343 (650) ⁽⁶⁾	

1. Refer to table 2 for trim materials.
2. Trim 2 limited to 149°C (300°F) maximum for nonlubricating fluids.
3. Cast iron is limited to -73°C (-100°F) minimum.
4. Plug-cage seals limit this design to 232°C (450°F) maximum.
5. May be used down to -254°C (-425°F) if manufacturing process includes Charpy impact test.
6. Only available in YD constructions.

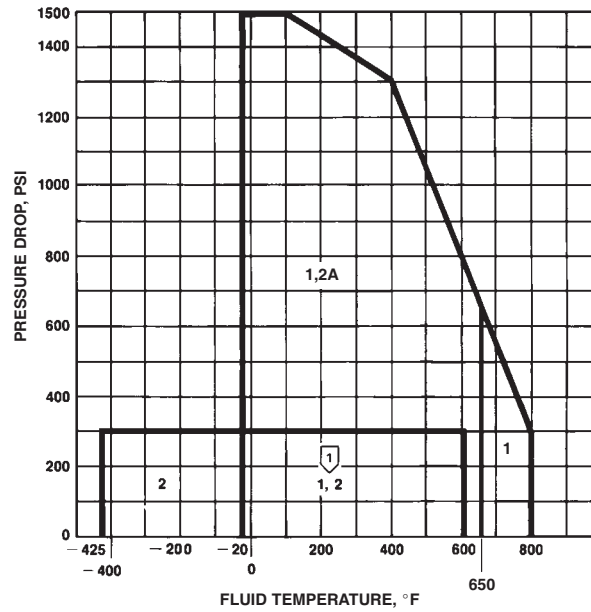

NOTE:
1 TRIM 2 LIMITED TO 300°F MAXIMUM
 FOR NONLUBRICATING FLUIDS

10A8091-B
A1892-3/IL

Figure 7. Maximum Allowable Pressure Drops and Temperatures for Table 2 Trims

Product Bulletin

51.1:YD
April 2010

YD and YS Valves

Table 6. Maximum Allowable Fisher YD Shutoff Pressure Drops with 657 and 667 Actuators⁽¹⁾

PACKING TYPE	ACTUATOR SIZE	NOMINAL (ACTUAL) AIR TO DIAPHRAGM, PSIG ⁽²⁾						
		3-15 (0-18)			6-30 (0-33)			3-40 (0-43)
		ΔP , PSID/(Bench Set, PSIG)/Spring Drawing Number						
1.3125 Inch Port, Class IV Seat Leakage								
Standard Single or Double PTFE	30	100 (5-13) 1F1768	500 (6-12) 1F1767	925 (7-11) ⁽³⁾ 1J1722	500 (6-26) 1E7953	1335 (8-24) 1J2581	1500 (10-22) 1E7923	---
	34	1130 (5-13) 1E8053	1500 (6-12) 1E8056	---	1500 (6-26) 1E8051	---	---	---
ENVIRO-SEAL PTFE	30	290 (7-11) 1J1722	---	---	710 (8-24) 1J2581	1500 (10-22) 1E7923	---	---
	34	500 (5-13) 1E8053	1125 (6-12) 1E8056	---	1125 (6-26) 1E8051	1500 (8-24) 1E8055	---	---
ENVIRO-SEAL Graphite ULF	30	---	---	---	---	---	---	540 (14-28) 1F7143
	34	---	---	---	955 (10-22) 1E8058	1500 (12-20) 1E8053	---	1500 (13-29) 1E8055
1.3125 Inch Port, Class II Seat Leakage (High-Temperature Trim)								
Graphite Ribbon/Filament (CL600)	30	---	---	---	320 (8-24) 1J2581	1500 (11-21) 1F1769	---	---
	34	110 (5-13) 1E8053	740 (6-12) 1E8056	1370 (7-11) 1F1771	740 (6-26) 1E8051	1500 (8-24) 1J2581	---	---
ENVIRO-SEAL Graphite ULF	30	---	---	---	30 (11-21) 1F1769	450 (12-20) 1F1768	---	1300 (14-28) 1F7143
	34	---	---	---	450 (8-24) 1E8055	1500 (10-22) 1E8058	---	---
2.3125 Inch Port, Class IV Seat Leakage								
Standard Single or Double PTFE	40	250 (6-12) 1F1771	---	---	250 (6-26) 1E8054	600 (7-25) 1E8058	1500 (10-22) 1E8053	---
	45	275 (4-14) 1E8270	820 (5-12) 1E8269	1350 (6-11) 1F1773	1350 (6-26) 1E8263	1500 (8-25) 1E8271	---	---
ENVIRO-SEAL PTFE	40	---	---	---	120 (7-25) 1E8058	820 (9-24) 1E8057	1170 (10-22) 1E8053	1500 (12-30) 1E8058
	45	330 (5-12) 1E8269	870 (6-11) 1F1773	---	865 (6-26) 1E8263	1500 (8-25) 1E8271	---	---
ENVIRO-SEAL Graphite ULF	45	---	---	---	430 (9-24) 1E8268	1500 (11-22) 1E8272	---	---
	46	385 (6-12) 1E8266	---	---	385 (6-26) 1E8258	1500 (8-24) 1E8264	---	---
2.3125 Inch Port, Class II Seat Leakage (High-Temperature Trim)								
Graphite Ribbon/Filament (CL600)	40	---	---	---	90 (7-25) 1E8058	790 (9-24) 1E8057	1145 (10-22) 1E8053	1500 (12-30) 1E8058
	45	300 (5-12) 1E8269	840 (6-11) 1F1773	---	840 (6-26) 1E8263	1500 (8-25) 1E8271	---	---

-continued-

Table 6. Maximum Allowable Fisher YD Shutoff Pressure Drops with 657 and 667 Actuators⁽¹⁾ (continued)

PACKING TYPE	ACTUATOR SIZE	NOMINAL (ACTUAL) AIR TO DIAPHRAGM, PSIG ⁽²⁾						
		3-15 (0-18)			6-30 (0-33)			3-40 (0-43)
		ΔP, PSID/(Bench Set, PSIG)/Spring Drawing Number						
2.3125 Inch Port, Class II Seat Leakage (High-Temperature Trim) (Continued)								
ENVIRO-SEAL Graphite ULF	40	---	---	---	---	---	575 (12-30) 1E8058	
	45	---	---	---	635 (8-25) 1E8271	1500 (11-22) 1E8272	---	
	46	330 (5-13) 1E8272	1125 (6-12) 1E8266	---	1125 (6-12) 1E8258	1500 (8-24) 1E8264	---	
3.4375 Inch Port, Class IV Seat Leakage								
Standard Single or Double PTFE	40	---	---	---	---	---	230 (8-32) 1E8058	
	45	100 (5-12) 1F1773	650 (6-11) ⁽³⁾ 1E9215	---	650 (6-26) 1E8268	1500 (9-24) 1E8272	---	
ENVIRO-SEAL PTFE	45	150 (6-11) ⁽³⁾ 1E9215	---	---	150 (6-26) 1E8268	1500 (9-24) 1E8272	---	
	46	150 (4-14) 1E8272	1500 (6-12) 1E8269	---	1500 (6-26) 1E8267	---	---	
ENVIRO-SEAL Graphite ULF	45	---	---	---	250 (10-22) 1E8266	800 (11-20) 1E8269	1500 (13-29) 1E8261	
	46	---	---	---	460 (7-25) 1E8263	1500 (9-24) 1E8271	---	
3.4375 Inch Port, Class II Seat Leakage (High-Temperature Trim)								
Graphite Ribbon/ Filament (CL600)	40	---	---	---	---	---	85 (8-32) 1E8058	
	45	500 (6-11) ⁽³⁾ 1E9215	---	---	500 (6-26) 1E8268	1500 (9-24) 1E8272	---	
ENVIRO-SEAL Graphite ULF	45	---	---	---	815 (9-24) 1E8272	1500 (11-20) 1E8269	---	
	46	770 (6-12) 1E8269	---	---	770 (6-26) 1E8267	1500 (7-25) 1E8263	---	
4.375 Inch Port, Class IV Seat Leakage								
Standard Single or Double PTFE	45	50 (6-12) ⁽³⁾ 1E9215	---	---	50 (6-26) 1E8272	570 (7-25) 1E8270	1100 (8-24) 1E8266	1500 (9-33) 1E8265
	46	800 (5-13) 1E8269	---	---	1500 (6-26) 1E8271	---	---	
ENVIRO-SEAL PTFE	45	---	---	---	80 (7-25) 1E8270	620 (8-24) 1E8266	1150 (9-33) 1E8265	
	46	325 (5-13) 1E8269	---	---	1125 (6-26) 1E8271	1500 (7-23) 1E8265	---	
ENVIRO-SEAL Graphite ULF	45	---	---	---	---	---	200 (11-31) 1E8272	
	46	---	---	---	260 (7.5-21) 1E8272	---	---	

-continued-

Product Bulletin

51.1:YD
April 2010

YD and YS Valves

Table 6. Maximum Allowable Fisher YD Shutoff Pressure Drops with 657 and 667 Actuators⁽¹⁾ (continued)

PACKING TYPE	ACTUATOR SIZE	NOMINAL (ACTUAL) AIR TO DIAPHRAGM, PSIG ⁽²⁾						
		3-15 (0-18)			6-30 (0-33)		3-40 (0-43)	
		ΔP, PSID/(Bench Set, PSIG)/Spring Drawing Number						
4.375 Inch Port, Class II Seat Leakage (High-Temperature Trim)								
Graphite Ribbon/ Filament (CL600)	45	200 (6-12) ⁽³⁾ 1E9215	---	---	200 (6-26) 1E8272	720 (7-25) 1E8270	1250 (8-24) 1E8266	1500 (9-33) 1E8265
	46	950 (5-13) 1E8269	---	---	1500 (6-26) 1E8271	---	---	---
ENVIRO-SEAL Graphite ULF	45	---	---	---	250 (8.5-24.5) 1E8266	---	---	520 (9-33) 1E8265
	46	70 (5.5-11.5) 1F1773	---	---	470 (6-26) 1E8271	1260 (7-23) 1E8265	1500 (7.5-21) 1E8272	---
7 Inch Port, Class IV Seat Leakage⁽⁴⁾								
Standard Single or Double PTFE	50	---	---	---	---	---	---	370 (11-31) 1E8272
	60	---	---	---	405 (7.5-21) 1E8272	---	---	---
	70	250 (5-13) 1N1286	---	---	750 (6-26) 1N7193	1500 (8-23) 1N1287	---	---
ENVIRO-SEAL PTFE	50	---	---	---	---	---	---	60 (11-31) 1E8272
	60	---	---	---	95 (7.5-21) 1E8272	---	---	---
	70	---	---	---	430 (6-26) 1N7193	1450 (8-23) 1N1287	1500 (10-22) 1N1284	---
ENVIRO-SEAL Graphite ULF	76 (667 only)	---	---	---	---	---	---	200 (13-29) 1N1284
	70	---	---	---	590 (10-22) 1N1284	---	---	1500 (13-28) 1N1287
7 Inch Port, Class II Seat Leakage (High-Temperature Trim)								
Graphite Ribbon/ Filament (CL600)	50	---	---	---	---	---	---	125 (11-31) 1E8272
	60	---	---	---	160 (7.5-21) 1E8272	---	---	---
	70	---	---	---	500 (6-26) 1N7193	1500 (8-23) 1N1287	---	---
ENVIRO-SEAL Graphite ULF	76 (667 only)	---	---	---	490 (11-22) ⁽³⁾ 1N1286	---	---	1200 (13-29) 1N1284
	70	---	---	---	590 (8-23) 1N1287	1500 (10-22) 1N1284	---	---

1. Spring and bench sets selected for use with either 657 or 667. Other acceptable configurations possible from Fisher Specification Manager for a specific actuator type.
 2. The bench set values shown assume an actual supply pressure to the actuator of 0 to 18 psig for a nominal 3 to 15 psig signal, an actual 0 to 33 psig supply for a nominal 6 to 30 psig signal, and an actual 0 to 43 psig supply for a nominal 3 to 40 psig signal. Any positioner or controller used with these actuators must be capable of delivering the appropriate slightly extended range.
 3. Requires non-standard spring adjuster.
 4. Special Class IV seat load (40 lb/lineal inch) used for YD with 7-inch diameter port.

Table 7. Maximum Allowable Fisher YS (Converging Service) Shutoff Pressure Drops with 657 and 667 Actuators⁽¹⁾

PACKING TYPE	ACTUATOR SIZE	NOMINAL (ACTUAL) AIR TO DIAPHRAGM, PSIG ⁽²⁾						
		3-15 (0-18)			6-30 (0-33)			3-40 (0-43)
		ΔP , PSID/(Bench Set, PSIG)/Spring Drawing Number						
1.3125 Inch Port, Class IV Seat Leakage								
Standard Single or Double PTFE	30	40 (6-12) 1F1767	75 (7-11) ⁽³⁾ 1J1722	---	110 (8-24) 1J2581	180 (10-22) 1E7923	245 (12-20) 1F1768	315 (14-28) 1F7143
	34	95 (5-13) 1E8053	145 (6-12) 1E8056	195 (7-11) 1F1771	245 (8-24) 1E8055	350 (10-22) 1E8058	450 (12-20) 1E8053	550 (14-28) 1E8054
ENVIRO-SEAL PTFE	30	25 (7-11) ⁽³⁾ 1J1722	---	---	60 (8-24) 1J2581	125 (10-22) 1E7923	195 (12-20) 1F1768	265 (14-28) 1F7143
	34	40 (5-13) 1E8053	95 (6-12) 1E8056	145 (7-11) 1F1771	195 (8-24) 1E8055	300 (10-22) 1E8058	400 (12-20) 1E8053	500 (14-28) 1E8054
ENVIRO-SEAL Graphite ULF	30	---	---	---	---	---	---	45 (14-28) 1F7143
	34	---	---	---	80 (10-22) 1E8058	180 (12-20) 1E8053	---	285 (14-28) 1E8054
Graphite Ribbon/ Filament (CL300)	30	---	---	---	10 (8-24) 1J2581	80 (10-22) 1E7923	150 (12-20) 1F1768	215 (14-28) 1F7143
	34	45 (6-12) 1E8056	95 (7-11) 1F1771	---	145 (8-24) 1E8055	250 (10-22) 1E8058	350 (12-20) 1E8053	450 (14-28) 1E8054
2.3125 Inch Port, Class IV Seat Leakage								
Standard Single or Double PTFE	40	12 (6-12) 1F1771	---	---	28 (7-25) 1E8058	61 (9-24) 1E8057	78 (10-22) 1E8053	110 (12-30) 1E8058
	45	38 (5-12) 1E8269	63 (6-11) 1F1773	---	113 (8-25) 1E8271	188 (11-22) 1E8272	213 (12-21) 1E8266	263 (14-28) 1E8265
ENVIRO-SEAL PTFE	40	---	---	---	38 (9-24) 1E8057	55 (10-22) 1E8053	---	88 (12-30) 1E8058
	45	15 (5-12) 1E8269	40 (6-11) 1F1773	---	90 (8-25) 1E8271	165 (11-22) 1E8272	190 (12-21) 1E8266	240 (14-28) 1E8265
ENVIRO-SEAL Graphite ULF	45	---	---	---	70 (11-22) 1E8272	95 (12-21) 1E8266	---	145 (14-28) 1E8265
	46	18 (6-12) 1E8266	---	---	55 (7-25) 1E8257	130 (9-24) 1E8267	240 (12-21) 1E8265	(667 Only) 315 (14-28) 1E8263
Graphite Ribbon/ Filament (CL300)	40	---	---	---	24 (9-24) 1E8057	40 (10-22) 1E8053	---	73 (12-30) 1E8058
	45	26 (6-11) 1F1773	---	---	76 (8-25) 1E8271	151 (11-22) 1E8272	176 (12-21) 1E8266	226 (14-28) 1E8265

-continued-

Product Bulletin

51.1:YD
April 2010

YD and YS Valves

Table 7. Maximum Allowable Fisher YS (Converging Service) Shutoff Pressure Drops with 657 and 667 Actuators⁽¹⁾ (continued)

PACKING TYPE	ACTUATOR SIZE	NOMINAL (ACTUAL) AIR TO DIAPHRAGM, PSIG ⁽²⁾						
		3-15 (0-18)			6-30 (0-33)			3-40 (0-43)
		ΔP , PSID/(Bench Set, PSIG)/Spring Drawing Number						
3.4375 Inch Port, Class IV Seat Leakage								
Standard Single or Double PTFE	40	---	---	---	---	---	5 (8-32) 1E8058	
	45	13 (6-11) ⁽³⁾ 1E9215	---	---	25 (7-25) 1E8265	47 (9-24) 1E8272	70 (11-20) 1E8269	104 (14-29) 1E8272
	46	30 (5-13) 1E8266	46 (6-12) 1E8269	---	80 (8-24) 1E8262	114 (10-22) 1E8265	130 (11-21) 1E8261	(667 Only) 147 (12-27) 1E8271
ENVIRO-SEAL PTFE	45	5 (6-11) ⁽³⁾ 1E9215	---	---	15 (7-25) 1E8265	37 (9-24) 1E8272	60 (11-20) 1E8269	94 (14-29) 1E8272
	46	19 (5-13) 1E8266	36 (6-12) 1E8269	---	70 (8-24) 1E8262	103 (10-22) 1E8265	120 (11-22) 1E8261	(667 Only) 137 (12-27) 1E8271
ENVIRO-SEAL Graphite ULF	45	---	---	---	17 (11-20) 1E8269	---	---	50 (14-29) 1E8272
	46	---	---	---	27 (8-24) 1E8262	60 (10-22) 1E8265	77 (11-21) 1E8261	(667 Only) 94 (12-27) 1E8271
Graphite Ribbon/ Filament (CL300)	45	---	---	---	8 (7-25) 1E8265	31 (9-24) 1E8272	53 (11-20) 1E8269	87 (14-29) 1E8272
	46	13 (5-13) 1E8266	30 (6-12) 1E8269	---	63 (8-24) 1E8262	97 (10-22) 1E8265	114 (11-21) 1E8261	(667 Only) 130 (12-27) 1E8271
4.375 Inch Port, Class IV Seat Leakage								
Standard Single or Double PTFE	45	---	---	---	15 (8-24) 1E8266	---	---	35 (11-31) 1E8272
	46	16 (5.5-11.5) 1F1773	---	---	21 (6-26) 1E8271	36 (7.5-21) 1E8272	---	---
	76 ⁽⁴⁾ (667 Only)	---	---	---	39 (8-24) 1N1284	70 (11-22) ⁽³⁾ 1N1286	---	112 (15-26) ⁽³⁾ 1N1286
	70 ⁽⁴⁾	29 (5-13) 1N1286	---	---	44 (6-26) 1N7193	88 (9-24) 1N1287	102 (10-22) 1N1284	161 (14-29) 1N1287
ENVIRO-SEAL PTFE	45	---	---	---	8 (8-24) 1E8266	---	---	29 (11-31) 1E8272
	46	9 (5.5-11.5) 1F1773	---	---	14 (6-26) 1E8271	30 (7.5-21) 1E8272	---	---
	76 ⁽⁴⁾ (667 Only)	---	---	---	30 (8-24) 1N1284	61 (11-22) ⁽³⁾ 1N1286	---	102 (15-26) ⁽³⁾ 1N1286
	70 ⁽⁴⁾	20 (5-13) 1N1286	---	---	35 (6-26) 1N7193	79 (9-24) 1N1287	93 (10-22) 1N1284	152 (14-29) 1N1287
ENVIRO-SEAL Graphite ULF	76 ⁽⁴⁾ (667 Only)	---	---	---	---	---	85 (15-26) ⁽³⁾ 1N1286	

-continued-

YD and YS Valves

Table 7. Maximum Allowable Fisher YS (Converging Service) Shutoff Pressure Drops with 657 and 667 Actuators⁽¹⁾ (continued)

PACKING TYPE	ACTUATOR SIZE	NOMINAL (ACTUAL) AIR TO DIAPHRAGM, PSIG ⁽²⁾						
		3-15 (0-18)			6-30 (0-33)		3-40 (0-43)	
		ΔP , PSID/(Bench Set, PSIG)/Spring Drawing Number						
4.375 Inch Port, Class IV Seat Leakage (Continued)								
ENVIRO-SEAL Graphite ULF	70 ⁽⁴⁾	---	---	---	25 (9-24) 1N1287	39 (10-22) 1N1284	99 (14-29) 1N1287	
Graphite Ribbon/ Filament (CL300)	45	---	---	---	4 (8-24) 1E8266	---	25 (11-31) 1E8272	
	46	5 (5.5-11.5) 1F1773	---	---	10 (6-26) 1E8271	26 (7.5-21) 1E8272	---	
	76 ⁽⁴⁾ (667 Only)	---	---	---	17 (8-24) 1N1284	48 (11-22) ⁽³⁾ 1N1286	90 (15-26) ⁽³⁾ 1N1286	
	70 ⁽⁴⁾	7 (5-13) 1N1286	---	---	22 (6-26) 1N7193	66 (9-24) 1N1287	81 (10-22) 1N1284	139 (14-29) 1N1287
7-Inch Port, Class IV Seat Leakage⁽⁵⁾								
Standard Single or Double PTFE	60	---	---	---	5 (7.5-21) 1E8272	---	---	
	76 (667 Only)	---	---	---	7 (8-24) 1N1284	19 (11-22) ⁽³⁾ 1N1286	35 (15-26) ⁽³⁾ 1N1286	
	70	3 (5-13) 1N1286	---	---	8 (6-26) 1N7193	26 (9-24) 1N1287	31 (10-22) 1N1284	54 (14-29) 1N1287
	80 ⁽⁴⁾	10 (5-13) 1H7477	---	---	25 (7-26) 1H7476	39 (8-24) 1H7473	47 (9-22) 1H7475	77 (13-29) 1H7473
ENVIRO-SEAL PTFE	76 (667 Only)	---	---	---	15 (11-22) ⁽³⁾ 1N1286	---	---	31 (15-26) ⁽³⁾ 1N1286
	70	---	---	---	5 (6-26) 1N7193	22 (9-24) 1N1287	28 (10-22) 1N1284	51 (14-29) 1N1287
	80 ⁽⁴⁾	5 (5-13) 1H7477	---	---	20 (7-26) 1H7476	34 (8-24) 1H7473	42 (9-22) 1H7475	103 (13-29) 1H7473
ENVIRO-SEAL Graphite ULF	76 (667 Only)	---	---	---	---	---	---	10 (15-26) ⁽³⁾ 1N1286
	70	---	---	---	7 (10-22) 1N1284	---	---	30 (14-29) 1N1287
	80 ⁽⁴⁾	---	---	---	7 (9-22) 1H7475	---	---	36 (13-29) 1H7473
Graphite Ribbon/ Filament (CL300)	76 (667 Only)	---	---	---	10 (11-22) ⁽³⁾ 1N1286	---	---	27 (15-26) ⁽³⁾ 1N1286
	70	---	---	---	17 (9-24) 1N1287	23 (10-22) 1N1284	---	46 (14-29) 1N1287
	80 ⁽⁴⁾	---	---	---	13 (7-26) 1H7476	27 (8-24) 1H7473	35 (9-22) 1H7475	65 (13-29) 1H7473

1. Spring and bench sets selected for use with either 657 or 667. Other acceptable configurations possible from Fisher Specification Manager for a specific actuator type.
2. The bench set values shown assume an actual supply pressure to the actuator of 0 to 18 psig for a nominal 3 to 15 psig signal, an actual 0 to 33 psig supply for a nominal 6 to 30 psig signal, and an actual 0 to 43 psig supply for a nominal 3 to 40 psig signal. Any positioner or controller used with these actuators must be capable of delivering the appropriate slightly extended range.
3. Requires non-standard spring adjustor.
4. Oversize yoke boss required.
5. Special Class 4 seat load (40 lb/lineal inch) used for YS, 7-inch port.

Product Bulletin

51.1:YD
April 2010

YD and YS Valves

Table 8. Maximum Allowable Fisher YS (Diverging Service) Shutoff Pressure Drops with 657 and 667 Actuators (ON-OFF) application only—No throttling service⁽¹⁾

PACKING TYPE	ACTUATOR SIZE	NOMINAL (ACTUAL) AIR TO DIAPHRAGM, PSIG ⁽²⁾		
		3-15 (0-18)	6-30 (0-33)	3-40 (0-43)
		$\Delta P^{(6)}$, PSID/(Bench Set, PSIG) ⁽⁷⁾ /Spring Drawing Number		
1.3125 Inch Port, Class IV Seat Leakage				
Standard Single or Double PTFE	30	195 (5-13) 1F1768	450 (4.5-28.5) 1E7924	---
	34	315 (3-15) 1E8058	600 (4.5-28.5) 1E8052	---
ENVIRO-SEAL PTFE	30	145 (7-11) ⁽³⁾ 1J1722	385 (8-24) 1J2581	---
	34	265 (5-13) 1E8053	600 (6-26) 1E8051	---
ENVIRO-SEAL Graphite ULF	34	---	400 (10-22) 1E8058	---
Graphite Ribbon/ Filament (CL300)	30	---	330 (8-24) 1J2581	---
	34	210 (6-12) 1E8056	570 (6-26) 1E8051	---
2.3125 Inch Port, Class IV Seat Leakage				
Standard Single or Double PTFE	40	50 (6-12) 1F1771	210 (6-26) 1E8054	---
	45	155 (4-14) 1E8270	330 (4-28) 1E8264	---
ENVIRO-SEAL PTFE	40	---	190 (7-25) 1E8058	---
	45	120 (5-12) 1E8269	310 (6-26) 1E8263	---
ENVIRO-SEAL Graphite ULF	45	---	225 (9-24) 1E8268	---
	46	120 (6-12) 1E8266	380 (7-25) 1E8257	---
Graphite Ribbon/ Filament (CL300)	40	---	280 (9-24) 1E8057	---
	45	105 (6-11) 1F1773	295 (6-26) 1E8263	---

-continued-

Table 8. Maximum Allowable Fisher YS (Diverging Service) Shutoff Pressure Drops with 657 and 667 Actuators (ON-OFF) application only—No throttling service⁽¹⁾ (continued)

PACKING TYPE	ACTUATOR SIZE	NOMINAL (ACTUAL) AIR TO DIAPHRAGM, PSIG ⁽²⁾		
		3-15 (0-18)	6-30 (0-33)	3-40 (0-43)
		$\Delta P^{(6)}$, PSID/(Bench Set, PSIG) ⁽⁷⁾ /Spring Drawing Number		
3.4375 Inch Port, Class IV Seat Leakage				
Standard Single or Double PTFE	40	---	---	125 (8-32) 1E8058
	45	65 (5-12) 1F1773	150 (6-26) 1E8268	---
	46	110 (4-14) 1E8272	225 (6-26) 1E8267	---
ENVIRO-SEAL PTFE	45	55 (6-11) ⁽³⁾ 1E9215	140 (6-26) 1E8268	---
	46	100 (4-14) 1E8272	215 (4-28) 1E8257	---
ENVIRO-SEAL Graphite ULF	45	---	95 (10-22) 1E8266	---
	46	---	170 (7-25) 1E8263	---
Graphite Ribbon/ Filament (CL300)	45	---	130 (7-25) 1E8265	---
	46	90 (5-13) 1E8266	210 (6-26) 1E8267	---
4.375 Inch Port, Class IV Seat Leakage				
Standard Single or Double PTFE	45	40 (6-12) ⁽³⁾ 1E9215	90 (6-26) 1E8272	---
	46	65 (5-13) 1E8269	140 (6-26) 1E8271	---
ENVIRO-SEAL PTFE	45	---	85 (7-25) 1E8270	---
	46	60 (5-13) 1E8269	135 (6-26) 1E8271	---
ENVIRO-SEAL Graphite ULF	45	---	---	55 (11-31) 1E8272
	46	---	50 (7.5-21) 1E8272	---
	70 ⁽⁴⁾	---	135 (9-24) 1N1287	---
Graphite Ribbon/ Filament (CL300)	45	---	80 (8-24) 1E8266	---
	46	55 (5-13) 1E8269	130 (6-26) 1E8271	---

-continued-

Product Bulletin

51.1:YD
April 2010

YD and YS Valves

Table 8. Maximum Allowable Fisher YS (Diverging Service) Shutoff Pressure Drops with 657 and 667 Actuators (ON-OFF) application only—No throttling service⁽¹⁾ (continued)

PACKING TYPE	ACTUATOR SIZE	NOMINAL (ACTUAL) AIR TO DIAPHRAGM, PSIG ⁽²⁾		
		3-15 (0-18)	6-30 (0-33)	3-40 (0-43)
		$\Delta P^{(6)}$, PSID/(Bench Set, PSIG) ⁽⁷⁾ /Spring Drawing Number		
7-Inch Port, Class IV Seat Leakage⁽⁵⁾				
Standard Single or Double PTFE	50	---	---	50 (11-31) 1E8272
	60	---	45 (7.5-21) 1E8272	---
	70	35 (5-13) 1N1286	75 (6-26) 1N7193	---
ENVIRO-SEAL PTFE	50	---	---	45 (11-31) 1E8272
	60	---	40 (7.5-21) 1E8272	---
	70	30 (5-13) 1N1286	70 (6-26) 1N7193	---
ENVIRO-SEAL Graphite ULF	76 (667 Only)	---	---	50 (13-29) 1N1284
	70	---	50 (10-22) 1N1284	---
Graphite Ribbon/ Filament (CL300)	76 (667 Only)	---	45 (11-22) ⁽³⁾ 1N1286	---
	70	---	70 (6-26) 1N7193	---

1. Spring and bench sets selected for use with either 657 or 667. Other acceptable configurations possible from Fisher Specification Manager for a specific actuator type.
2. The bench set values shown assume an actual supply pressure to the actuator of 0 to 18 psig for a nominal 3 to 15 psig signal, an actual 0 to 33 psig supply for a nominal 6 to 30 psig signal, and an actual 0 to 43 psig supply for a nominal 3 to 40 psig signal. Any positioner or controller used with these actuators must be capable of delivering the appropriate slightly extended range.
3. Requires non-standard spring adjuster.
4. Oversize yoke boss required.
5. Special Class 4 seat load (40 lb/lineal inch) used for YS, 7-inch port.
6. Assumes same shutoff pressure drop for top and bottom ports.
7. Bench sets selected will provide sufficient seat loading, even with no pressure drop. The selected bench sets will enable the actuator to fully stroke the valve up or down with the maximum shutoff drop listed.

Installation

Although YD and YS valves may be mounted with the actuator in any position relative to the valve, the normal position is with the valve in a horizontal run of pipe and the actuator vertical above the valve.

The actuator should be supported in any position other than vertical. Orient the valve so that valve plug positions and flow directions will conform to the flow indicator plate on the valve body.

Dimensions are shown in figure 8.

YD and YS Valves

Table 9. Fisher YD and YS Dimensions

VALVE MATERIAL AND SIZE, NPS	DIMENSION																	
	A							D										
	Valve Rating and End Connection Style ⁽¹⁾							Standard Bonnet				Extension Bonnet						
	CAST IRON ⁽²⁾	Screwed	CL125 FF	---	CL250 RF	---	---	---	Stem Diameter, mm (Inches)				Stem Diameter, mm (Inches)				Stem Diameter, mm (Inches)	
9.5 (3/8)									12.7 (1/2)	19.1 (3/4)	25.4 (1)	9.5 (3/8)	12.7 (1/2)	19.1 (3/4)	25.4 (1)	9.5 (3/8)	12.7 (1/2)	19.1 (3/4)
STEEL & SST	Screwed & SWE	CL150 RF	CL150 RTJ	CL300 RF	CL300 RTJ	CL600 RF & BWE	CL600 RTJ	9.5 (3/8)	12.7 (1/2)	19.1 (3/4)	25.4 (1)	9.5 (3/8)	12.7 (1/2)	19.1 (3/4)	25.4 (1)	9.5 (3/8)	12.7 (1/2)	19.1 (3/4)
mm																		
1/2, 3/4 ⁽²⁾	209.6	---	---	---	---	---	---	127.0	149.4	---	---	212.9	251.0	---	---	303.3	319.0	---
1 ⁽²⁾	209.6	184.2	196.9	196.9	209.6	209.6	209.6	127.0	149.4	---	---	212.9	251.0	---	---	303.3	319.0	---
1-1/2	251.0	222.3	235.0	235.0	247.7	251.0	251.0	127.0	149.4	---	---	212.9	251.0	---	---	303.3	319.0	---
2	285.8	254.0	266.7	266.7	282.4	285.8	289.1	---	171.5	168.1	---	---	273.1	277.9	---	---	471.1	468.4
2-1/2	---	276.4	289.1	292.1	307.8	311.2	314.5	---	171.5	168.1	---	---	273.1	277.9	---	---	471.1	468.4
3	---	298.5	311.1	317.5	333.2	336.6	339.9	---	195.3	192.0	---	---	296.9	301.8	---	---	500.1	505.0
4	---	352.6	365.3	368.3	384.0	393.7	396.7	---	228.6	225.6	---	---	330.2	335.0	---	---	533.4	525.5
6	---	450.9	463.6	472.9	489.0	508.0	511.0	---	---	242.8	287.3	---	---	349.3	419.1	---	---	534.9
8	---	543.1	555.8	568.5	584.2	609.6	612.9	---	---	323.9	---	---	---	---	---	---	---	---
Inches																		
1/2, 3/4 ⁽²⁾	8.25	---	---	---	---	---	---	5.00	5.88	---	---	8.38	9.88	---	---	11.94	12.56	---
1 ⁽²⁾	8.25	7.25	7.75	7.75	8.25	8.25	8.25	5.00	5.88	---	---	8.38	9.88	---	---	11.94	12.56	---
1-1/2	9.88	8.75	9.25	9.25	9.75	9.88	9.88	5.00	5.88	---	---	8.38	9.88	---	---	11.94	12.56	---
2	11.25	10.00	10.50	10.50	11.12	11.25	11.38	---	6.75	6.62	---	---	10.75	10.94	---	---	18.56	18.44
2-1/2	---	10.88	11.38	11.50	12.12	12.25	12.38	---	6.75	6.62	---	---	10.75	10.94	---	---	18.56	18.44
3	---	11.75	12.25	12.50	13.12	13.25	13.38	---	7.69	7.56	---	---	11.69	11.88	---	---	19.69	19.88
4	---	13.88	14.38	14.50	15.12	15.50	15.62	---	9.00	8.88	---	---	13.00	13.19	---	---	21.00	20.69
6	---	17.75	18.25	18.62	19.25	20.00	20.12	---	---	9.56	11.31	---	---	13.75	16.50	---	---	21.06
8	---	21.38	21.88	22.38	23.00	24.00	24.13	---	---	12.75	---	---	---	---	---	---	---	---

1. Abbreviations are: BWE, butt weld ends; FF, flat-face flanges; RF, raised-face flanges; RTJ, ring-type joint flanges; SWE, socket weld ends.
2. NPS 1/2, 3/4, and 1 are not available in cast iron material.

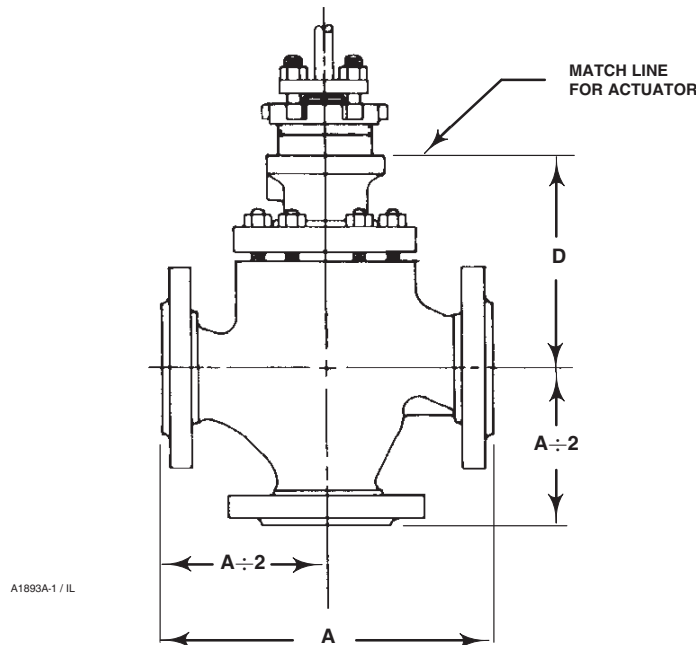

Figure 8. Fisher YD and YS Dimensions (also see table 9)

Table 10. Bonnet Selection Guidelines

BONNET STYLE	PACKING MATERIAL	IN-BODY PROCESS TEMPERATURE LIMITS ⁽¹⁾	
		°C	°F
Plain (standard)	PTFE V-ring	-18 to 232	0 to 450
	PTFE/composition	-18 to 232	0 to 450
	Graphite ribbon/filament	-18 to max shown in table 5	0 to max shown in table 5
Style 1 cast extension	PTFE V-ring	-46 to 427	-50 to 800
	PTFE/composition		
	Graphite ribbon/filament	-46 to max shown in table 5	-50 to max shown in table 5
Style 2 cast extension	PTFE V-ring	-101 to 427	-150 to 800
	PTFE/composition		
	Graphite ribbon/filament	-101 to max shown in table 5	-150 to max shown in table 5
ENVIRO-SEAL bellows seal bonnet	PTFE	For exceptional stem sealing capabilities. See bulletin 59.1:070, ENVIRO-SEAL Bellows Seal Bonnets, for pressure/temperature ratings.	
	Graphite	For exceptional stem sealing capabilities. See bulletin 59.1:070, ENVIRO-SEAL Bellows Seal Bonnets, for pressure/temperature ratings.	

1. These in-body process temperatures assume an outside, ambient temperature of 21°C (70°F) and no insulation on the bonnet. When using any packing at low process temperatures, a cast extension bonnet may have to be used to prevent the packing damage which could result from the formation of valve stem frost. Material selection for trim and other components will also be limiting factors.

Ordering Information

Application Information

When ordering, specify:

1. Type of application
 - a. Converging or diverging flow
 - b. Throttling or on-off (flow switching)
 - c. Reducing or relief
2. Controlled fluid (include chemical analysis of fluid if possible)
3. Specific gravity of controlled fluid
4. Fluid temperature
5. Range of flowing inlet pressures
6. Pressure drops
 - a. Range of flowing pressure drops
 - b. Maximum at shutoff

7. Flow rates

- a. Minimum controlled flow
- b. Normal flow
- c. Maximum flow

8. Shutoff classification required (see the Specifications)

9. Line size and schedule

Valve Information

Refer to the Specifications. Review the description to the right of each specification and in the referenced figures and tables. Indicate the desired choice wherever there is a selection to be made. Always indicate the valve design being ordered.

Actuator and Accessory Information

Refer to separate bulletins covering actuators and accessories for ordering information.

Coefficients

Table 11. Fisher YD, Converging Flow

Converging Flow																	Linear Characteristic	
Valve Size, NPS	Port Diameter		Maximum Travel		Flow Path ⁽¹⁾	Flow Coefficient	Valve Opening—Percent of Total Travel										F _L ⁽²⁾	
	mm	Inches	mm	Inches			0	10	20	30	40	50	60	70	80	90		100
							(Plug Down)											(Plug Up)
1/2	33.3	1.3125	19	0.75	R to B	C _V	8.37	7.10	6.68	5.94	4.97	4.03	3.10	2.15	1.49	1.30	0	0.81
						K _V	7.24	6.14	5.78	5.14	4.30	3.49	2.68	1.86	1.29	1.12	0.00	---
						X _T	0.562	0.452	0.432	0.442	0.456	0.473	0.494	0.504	0.529	0.574	---	---
					L to B	C _V	0	2.45	3.36	4.32	5.15	5.96	6.93	7.74	8.00	8.10	9.00	0.79
						K _V	0.00	2.12	2.91	3.74	4.45	5.16	5.99	6.70	6.92	7.01	7.79	---
						X _T	---	0.522	0.476	0.452	0.449	0.456	0.446	0.442	0.473	0.487	0.494	---
3/4	33.3	1.3125	19	0.75	R to B	C _V	12.3	10.7	10.1	8.94	7.42	5.83	4.24	2.77	1.85	1.59	0	0.77
						K _V	10.6	9.26	8.74	7.73	6.42	5.04	3.67	2.40	1.60	1.38	0.00	---
						X _T	0.494	0.466	0.446	0.442	0.446	0.469	0.490	0.551	0.616	---	---	
					L to B	C _V	0	2.93	4.19	5.57	7.11	8.68	9.91	10.6	11.2	11.4	12.5	0.76
						K _V	0.00	2.53	3.62	4.82	6.15	7.51	8.57	9.17	9.69	9.86	10.8	---
						X _T	---	0.466	0.432	0.429	0.422	0.413	0.429	0.466	0.459	0.459	0.483	---
1	33.3	1.3125	19	0.75	R to B	C _V	19.4	17.1	15.3	12.6	9.70	6.82	4.34	2.48	1.46	1.14	0	0.91
						K _V	16.8	14.8	13.2	10.9	8.39	5.90	3.75	2.15	1.26	0.99	0.00	---
						X _T	0.655	0.656	0.681	0.714	0.745	0.768	0.717	0.682	0.751	0.848	---	---
					L to B	C _V	0	3.08	4.58	6.62	9.20	12.0	15.0	17.1	18.0	18.7	19.4	0.96
						K _V	0.00	2.66	3.96	5.73	7.96	10.4	13.0	14.8	15.6	16.2	16.8	---
						X _T	---	0.572	0.609	0.623	0.627	0.614	0.629	0.642	0.681	0.687	0.717	---
1-1/2	33.3	1.3125	19	0.75	R to B	C _V	22.2	19.7	17.6	14.5	11.1	7.82	5.97	2.85	1.68	1.30	0	0.87
						K _V	19.2	17.0	15.2	12.5	9.60	6.76	5.16	2.47	1.45	1.12	0.00	---
						X _T	0.552	0.545	0.566	0.621	0.629	0.644	0.590	0.569	0.624	0.719	---	---
					L to B	C _V	0	3.54	5.28	7.61	10.6	13.8	17.2	19.6	20.7	21.5	22.3	0.94
						K _V	0.00	3.06	4.57	6.58	9.17	11.9	14.9	17.0	17.9	18.6	19.3	---
						X _T	---	0.479	0.504	0.522	0.521	0.507	0.528	0.538	0.568	0.574	0.598	---
2	58.7	2.3125	29	1.125	R to B	C _V	74.2	69.8	64.6	57.3	46.7	35.3	24.8	15.8	9.03	5.05	0	0.81
						K _V	64.2	60.4	55.9	49.6	40.4	30.5	21.5	13.7	7.81	4.37	0.00	---
						X _T	0.670	0.655	0.660	0.659	0.697	0.759	0.778	0.794	0.761	0.742	---	---
					L to B	C _V	0	4.90	7.80	12.8	19.7	28.1	38.4	49.3	58.4	64.9	71.9	0.93
						K _V	0.00	4.24	6.75	11.1	17.0	24.3	33.2	42.6	50.5	56.1	62.2	---
						X _T	---	0.743	0.694	0.686	0.712	0.748	0.750	0.752	0.748	0.731	0.744	---
2-1/2	58.7	2.3125	29	1.125	R to B	C _V	81.6	78.8	70.0	62.9	51.7	38.5	27.5	17.6	9.9	5.5	0	0.79
						K _V	70.6	68.2	60.5	54.4	44.7	33.3	23.8	15.2	8.56	4.76	0.00	---
						X _T	0.610	0.565	0.623	0.601	0.629	0.702	0.698	0.707	0.699	0.692	---	---
					L to B	C _V	0	5.4	8.58	14.3	21.9	30.8	41.8	53.9	63.8	71.5	79.2	0.91
						K _V	0.00	4.67	7.42	12.4	18.9	26.6	36.2	46.6	55.2	61.8	68.5	---
						X _T	---	0.671	0.633	0.605	0.635	0.685	0.697	0.697	0.690	0.664	0.674	---

-continued-

Product Bulletin

51.1:YD
April 2010

YD and YS Valves

Table 11. Fisher YD, Converging Flow (continued)

Valve Size, NPS	Port Diameter		Maximum Travel		Flow Path ⁽¹⁾	Flow Coefficient	Valve Opening—Percent of Total Travel										F _L ⁽²⁾	
	mm	Inches	mm	Inches			0 (Plug Down)	10	20	30	40	50	60	70	80	90		100 (Plug Up)
3	87.3	3.4375	38	1.5	R to B	C _v	143	133	121	107	91.1	73.7	56.6	39.0	20.9	8.64	0	0.74
						K _v	124	115	105	93	78.8	63.8	49.0	33.7	18.1	7.47	0.00	---
						X _T	0.594	0.632	0.680	0.696	0.714	0.754	0.734	0.673	0.711	0.873	---	---
					L to B	C _v	0	18.7	33.9	51.7	70.1	87.9	101	120	134	146	156	0.92
						K _v	0.00	16.2	29.3	44.7	60.6	76.0	87.4	104	116	126	135	---
						X _T	---	0.848	0.757	0.692	0.644	0.621	0.643	0.670	0.743	0.744	0.730	---
4	111.1	4.375	51	2	R to B	C _v	248	236	222	200	175	147	117	86.9	56.6	29.0	0	0.74
						K _v	215	204	192	173	151	127	101	75.2	49.0	25.1	0.00	---
						X _T	0.570	0.583	0.616	0.652	0.672	0.669	0.659	0.608	0.618	0.640	---	---
					L to B	C _v	0	10.2	26.5	49.7	78.4	113	154	189	216	241	265	0.92
						K _v	0.00	8.82	22.9	43.0	67.8	97.7	133	163	187	208	229	---
						X _T	---	0.658	0.622	0.616	0.625	0.631	0.643	0.683	0.704	0.711	0.752	---
6	177.8	7	51	2	R to B	C _v	451	424	387	338	282	223	162	108	60.1	22.9	0	0.84
						K _v	390	367	335	292	244	193	140	93.4	52.0	19.8	0.00	---
						X _T	0.757	0.721	0.727	0.749	0.750	0.747	0.776	0.770	0.749	0.774	---	---
					L to B	C _v	0	49.4	102	161	221	284	337	387	433	474	506	0.91
						K _v	0.00	42.7	88.2	139	191	246	292	335	375	410	438	---
						X _T	---	0.592	0.623	0.662	0.695	0.688	0.728	0.749	0.740	0.757	0.773	---
8 High Capacity	177.8	7	57.2	2.25	R to B	C _v	491	473	425	384	332	256	171	102	55	24	0	0.84
						K _v	425	409	368	332	287	221	148	88.2	47.6	20.8	0.00	---
						X _T	0.702	0.669	0.662	0.689	0.609	0.653	0.710	0.613	0.558	0.349	0	---
					L to B	C _v	0	10	34	62	103	170	264	361	446	527	588	0.91
						K _v	0.00	8.65	29.4	53.6	89.1	147	228	312	386	456	509	---
						X _T	0	0.731	0.891	0.838	0.861	0.900	0.850	0.712	0.654	0.629	0.735	---
8 Low Capacity	177.8	7	57.2	2.25	R to B	C _v	476	410	358	310	246	169	105	57.5	30.1	11.0	0	0.84
						K _v	412	355	310	268	213	146	91	49.7	26.0	9.52	0	---
						X _T	0.668	0.669	0.668	0.668	0.668	0.668	0.669	0.669	0.669	0.666	0	---
					L to B	C _v	0	12	25	47.9	88.1	144	213	283	376	461	542	0.91
						K _v	0	10.4	21.6	41.4	76.2	125	184	245	325	399	469	---
						X _T	0	0.655	0.603	0.607	0.608	0.608	0.608	0.608	0.608	0.608	0.608	---

1. The end connections are identified on the valve body.
2. At maximum flow.

YD and YS Valves

Table 12. Fisher YD, Diverging Flow

Diverging Flow																Linear Characteristic		
Valve Size, NPS	Port Diameter		Maximum Travel		Flow Path ⁽¹⁾	Flow Coefficient	Valve Opening—Percent of Total Travel										F _L ⁽²⁾	
	mm	Inches	mm	Inches			0 (Plug Down)	10	20	30	40	50	60	70	80	90		100 (Plug Up)
1/2	33.3	1.3125	19	0.75	B to R	C _V	9.25	8.47	8.19	7.74	6.97	5.92	4.54	3.08	2.19	2.02	0	0.80
						K _V	8.00	7.33	7.08	6.70	6.03	5.12	3.93	2.66	1.89	1.75	0.00	---
						X _T	0.518	0.473	0.422	0.410	0.439	0.515	0.620	0.714	0.689	0.727	---	---
					B to L	C _V	0	2.08	2.80	3.51	4.26	5.11	6.02	6.90	7.50	7.72	8.67	0.80
						K _V	0.00	1.80	2.42	3.04	3.68	4.42	5.21	5.97	6.49	6.68	7.50	---
						X _T	---	---	0.898	0.744	0.628	0.540	0.533	0.578	0.574	0.555	0.563	---
3/4	33.3	1.3125	19	0.75	B to R	C _V	13.0	12.1	11.5	10.5	9.17	7.48	5.49	3.57	2.49	2.34	0	0.77
						K _V	11.2	10.5	9.95	9.08	7.93	6.47	4.75	3.09	2.15	2.02	0.00	---
						X _T	0.537	0.537	0.522	0.529	0.574	0.628	0.648	0.636	0.620	0.648	---	---
					B to L	C _V	0	2.39	3.40	4.46	5.70	6.96	8.21	9.39	10.1	10.3	11.5	0.79
						K _V	0.00	2.07	2.94	3.86	4.93	6.02	7.10	8.12	8.74	8.91	9.95	---
						X _T	---	0.946	0.884	0.783	0.681	0.648	0.660	0.668	0.648	0.640	0.608	---
1	33.3	1.3125	19	0.75	B to R	C _V	19.4	18.1	16.3	14.5	12.5	9.68	6.58	4.04	2.73	2.40	0	0.89
						K _V	16.8	15.7	14.1	12.5	10.8	8.37	5.69	3.49	2.36	2.08	0.00	---
						X _T	0.632	0.666	0.694	0.674	0.614	0.616	0.549	0.455	0.537	0.515	---	---
					B to L	C _V	0	4.16	6.18	8.34	10.9	13.3	15.2	16.7	18.0	18.9	19.2	0.87
						K _V	0.00	3.60	5.35	7.21	9.43	11.5	13.1	14.4	15.6	16.3	16.6	---
						X _T	---	0.718	0.749	0.787	0.756	0.738	0.712	0.693	0.656	0.640	0.648	---
1-1/2	33.3	1.3125	19	0.75	B to R	C _V	23	20.9	18.9	16.8	13.3	9.90	6.90	4.36	2.53	2.06	0	0.89
						K _V	19.9	18.1	16.3	14.5	11.5	8.56	5.97	3.77	2.19	1.78	0.00	---
						X _T	0.604	0.604	0.599	0.599	0.565	0.559	0.525	0.522	0.492	0.487	---	---
					B to L	C _V	0	4.20	6.30	8.40	11.1	13.5	15.5	17.5	19.6	21.4	23	0.84
						K _V	0.00	3.63	5.45	7.27	9.60	11.7	13.4	15.1	17.0	18.5	19.9	---
						X _T	---	0.684	0.694	0.719	0.732	0.726	0.725	0.674	0.677	0.634	0.596	---
2	58.7	2.3125	29	1.125	B to R	C _V	74.2	73.1	69.7	64.2	55.0	44.5	32.6	21.0	12.7	8.77	0	0.90
						K _V	64.2	63.2	60.3	55.5	47.6	38.5	28.2	18.2	11.0	7.59	0.00	---
						X _T	0.750	0.756	0.760	0.754	0.762	0.739	0.712	0.734	0.680	0.651	---	---
					B to L	C _V	0	6.40	9.32	15.0	28.8	34.3	46.9	59.0	69.8	79.3	85.5	0.87
						K _V	0.00	5.54	8.06	13.0	24.9	29.7	40.6	51.0	60.4	68.6	74.0	---
						X _T	---	0.660	0.674	0.624	0.577	0.631	0.639	0.662	0.673	0.636	0.628	---
2-1/2	58.7	2.3125	29	1.125	B to R	C _V	77.9	76.7	73.2	67.4	57.7	46.7	34.4	22.1	13.3	9.21	0	0.89
						K _V	67.4	66.3	63.3	58.3	49.9	40.4	29.8	19.1	11.5	7.97	0.00	---
						X _T	0.723	0.729	0.735	0.734	0.743	0.715	0.680	0.710	0.659	0.628	---	---
					B to L	C _V	0	6.72	9.79	15.8	25.0	36.0	49.2	62.0	73.3	83.3	89.7	0.87
						K _V	0.00	5.81	8.47	13.7	21.6	31.1	42.6	53.6	63.4	72.1	77.6	---
						X _T	---	0.640	0.647	0.601	0.558	0.616	0.620	0.644	0.653	0.623	0.609	---

-continued-

Product Bulletin

51.1:YD
April 2010

YD and YS Valves

Table 12. Fisher YD, Diverging Flow (continued)

Valve Size, NPS	Port Diameter		Maximum Travel		Flow Path ⁽¹⁾	Flow Coefficient	Valve Opening—Percent of Total Travel										F _L ⁽²⁾	
	mm	Inches	mm	Inches			0 (Plug Down)	10	20	30	40	50	60	70	80	90		100 (Plug Up)
3	87.3	3.4375	38	1.5	B to R	C _v	146	146	146	143	128	106	81.1	55.0	29.8	16.4	0	0.87
						K _v	126	126	126	124	111	91.7	70.2	47.6	25.8	14.2	0.00	---
						X _T	0.687	0.716	0.733	0.687	0.686	0.689	0.688	0.684	0.684	0.688	---	---
					B to L	C _v	0	26.9	44.3	64.5	84.0	103	122	140	153	165	174	0.90
						K _v	0.00	23.3	38.3	55.8	72.7	89.1	106	121	132	143	151	---
						X _T	---	0.673	0.679	0.675	0.674	0.673	0.672	0.672	0.676	0.674	0.671	---
4	111.1	4.375	51	2	B to R	C _v	252	249	246	241	227	203	172	135	94.6	52.1	0	0.76
						K _v	218	215	213	208	196	176	149	117	81.8	45.1	0.00	---
						X _T	0.670	0.671	0.674	0.672	0.673	0.673	0.674	0.643	0.671	0.673	---	---
					B to L	C _v	0	12.0	28.0	50.2	79.7	119	172	226	267	297	316	0.91
						K _v	0.00	10.4	24.2	43.4	68.9	103	149	195	231	257	273	---
						X _T	---	0.691	0.689	0.692	0.691	0.692	0.691	0.688	0.687	0.887	0.690	---
6	177.8	7	51	2	B to R	C _v	483	470	444	395	343	273	203	134	74.8	33.0	0	0.89
						K _v	418	407	384	342	297	236	176	116	64.7	28.5	0.00	---
						X _T	0.783	0.780	0.781	0.785	0.791	0.781	0.786	0.785	0.784	0.786	---	---
					B to L	C _v	0	58.4	106	164	230	301	374	437	491	534	567	0.89
						K _v	0.00	50.5	91.7	142	199	260	324	378	425	462	490	---
						X _T	---	0.726	0.729	0.729	0.728	0.732	0.732	0.727	0.732	0.726	0.732	---
8 High Capacity	177.8	7	57.5	2.25	B to R	C _v	546	525	472	427	369	284	190	114	61	26	0	0.89
						K _v	472	454	408	369	319	246	164	98.6	52.8	22.5	0.00	---
						X _T	0.700	0.670	0.734	0.688	0.609	0.655	0.710	0.606	0.559	0.367	0	---
					B to L	C _v	0	12	37	68	114	189	293	401	495	586	653	0.89
						K _v	0.00	10.4	32.0	58.8	98.6	163	253	347	428	507	565	---
						X _T	0	0.628	0.929	0.860	0.858	0.899	0.824	0.712	0.655	0.625	0.735	---
8 Low Capacity	177.8	7	57.5	2.25	B to R	C _v	529	456	398	341	273	188	117	63.9	33.5	12.2	0	0.89
						K _v	458	394	344	295	236	163	101	55.3	29.0	10.6	0	---
						X _T	0.660	0.667	0.668	0.668	0.668	0.668	0.668	0.668	0.667	0.661	0	---
					B to L	C _v	0	14	28	53.2	97.9	160	236	315	418	512	602	0.89
						K _v	0	12.1	24.2	46.0	84.7	138	204	272	362	443	521	---
						X _T	0	0.594	0.594	0.608	0.608	0.608	0.608	0.608	0.608	0.608	0.608	---

1. The end connections are identified on the valve body.
2. At maximum flow.

Table 13. Fisher YS, Converging Flow

Converging Flow																	Linear Characteristic	
Valve Size, NPS	Port Diameter		Maximum Travel		Flow Path ⁽¹⁾	Flow Coeffi- cient	Valve Opening—Percent of Total Travel										F _L ⁽²⁾	
	mm	Inches	mm	Inches			0 (Plug Down)	10	20	30	40	50	60	70	80	90		100 (Plug Up)
1/2	33.3	1.3125	19	0.75	R to L	C _v	8.43	7.37	6.62	6.11	5.66	5.20	4.73	4.25	3.65	2.48	0	0.80
						K _v	7.29	6.38	5.73	5.29	4.90	4.50	4.09	3.68	3.16	2.15	0.00	---
						X _T	0.518	0.473	0.446	0.422	0.416	0.429	0.442	0.449	0.459	0.501	---	---
					B to L	C _v	0	1.74	2.44	3.16	3.61	4.10	4.95	5.85	6.38	7.07	8.42	0.80
						K _v	0.00	1.51	2.11	2.73	3.12	3.55	4.28	5.06	5.52	6.12	7.28	---
						X _T	---	0.936	0.819	0.744	0.761	0.697	0.559	0.469	0.456	0.490	0.526	---
3/4	33.3	1.3125	19	0.75	R to L	C _v	11.8	10.4	9.37	8.71	8.07	7.25	6.27	5.32	4.40	2.78	0	0.79
						K _v	10.2	9.00	8.11	7.53	6.98	6.27	5.42	4.60	3.81	2.40	0.00	---
						X _T	0.508	0.508	0.490	0.462	0.452	0.452	0.459	0.459	0.436	0.452	---	---
					B to L	C _v	0	2.65	3.72	4.87	6.30	7.43	8.29	9.16	9.97	11.2	12.5	0.77
						K _v	0.00	2.29	3.22	4.21	5.45	6.43	7.17	7.92	8.62	9.69	10.8	---
						X _T	---	0.533	0.508	0.494	0.446	0.397	0.397	0.436	0.446	0.432	0.497	---
1	33.3	1.3125	19	0.75	R to L	C _v	18.4	16.5	15.3	13.8	12.0	9.84	7.63	5.37	3.38	1.64	0	0.93
						K _v	15.9	14.3	13.2	11.9	10.4	8.51	6.60	4.65	2.92	1.42	0.00	---
						X _T	0.682	0.664	0.665	0.668	0.674	0.694	0.704	0.702	0.736	0.845	---	---
					B to L	C _v	0	2.11	3.03	4.45	6.15	8.18	10.5	13.0	15.7	18.3	20.5	0.88
						K _v	0.00	1.83	2.62	3.85	5.32	7.08	9.08	11.2	13.6	15.8	17.7	---
						X _T	---	0.602	0.722	0.691	0.674	0.646	0.644	0.646	0.626	0.594	0.613	---
1-1/2	33.3	1.3125	19	0.75	R to L	C _v	20.6	18.0	16.2	14.3	12.4	9.90	7.70	5.42	3.30	1.65	0	0.91
						K _v	17.8	15.6	14.0	12.4	10.7	8.56	6.66	4.69	2.85	1.43	0.00	---
						X _T	0.603	0.616	0.656	0.690	0.700	0.759	0.763	0.768	0.854	0.926	---	---
					B to L	C _v	0	2.60	4.90	6.90	9.40	12.6	15.4	18.8	22.0	24.5	25.1	0.82
						K _v	0.00	2.25	4.24	5.97	8.13	10.9	13.3	16.3	19.0	21.2	21.7	---
						X _T	---	0.453	0.315	0.328	0.330	0.313	0.342	0.353	0.365	0.379	0.468	---
2	58.7	2.3125	29	1.125	R to L	C _v	66.1	63.6	61.9	59.3	53.7	47.0	37.7	27.6	17.1	6.68	0	0.92
						K _v	57.2	55.0	53.5	51.3	46.5	40.7	32.6	23.9	14.8	5.78	0.00	---
						X _T	0.757	0.762	0.747	0.725	0.734	0.743	0.743	0.733	0.724	0.848	---	---
					B to L	C _v	0	3.85	5.48	9.16	14.6	21.5	30.7	42.4	56.3	71.9	85.6	0.65
						K _v	0.00	3.33	4.74	7.92	12.6	18.6	26.6	36.7	48.7	62.2	74.0	---
						X _T	---	0.911	0.883	0.801	0.772	0.756	0.745	0.731	0.697	0.656	0.608	---

-continued-

Product Bulletin

51.1:YD
April 2010

YD and YS Valves

Table 13. Fisher YS, Converging Flow (continued)

Valve Size, NPS	Port Diameter		Maximum Travel		Flow Path ⁽¹⁾	Flow Coefficient	Valve Opening—Percent of Total Travel										F _L ⁽²⁾	
	mm	Inches	mm	Inches			0 (Plug Down)	10	20	30	40	50	60	70	80	90		100 (Plug Up)
2-1/2	58.7	2.3125	29	1.125	R to L	C _V	72.8	70.0	68.0	65.3	59.2	51.7	41.5	30.3	18.8	7.35	0	0.89
						K _V	63.0	60.5	58.8	56.5	51.2	44.7	35.9	26.2	16.3	6.36	0.00	---
						X _T	0.691	0.677	0.684	0.659	0.664	0.676	0.681	0.667	0.662	0.662	---	---
					B to L	C _V	0	4.24	6.03	10.1	16.0	23.7	33.8	46.7	62.0	79.0	94.2	0.84
						K _V	0.00	3.67	5.22	8.74	13.8	20.5	29.2	40.4	53.6	68.3	81.5	---
						X _T	---	0.824	0.802	0.725	0.694	0.684	0.674	0.662	0.631	0.601	0.552	---
3	87.3	3.4375	38	1.5	R to L	C _V	140	131	121	111	99.3	85.3	68.3	46.1	23.9	9.07	0	0.86
						K _V	121	113	105	96.0	85.9	73.8	59.1	39.9	20.7	7.85	0.00	---
						X _T	0.713	0.714	0.714	0.713	0.716	0.712	0.715	0.716	0.713	0.711	---	---
					B to L	C _V	0	14.1	27.4	40.3	53.8	68.3	87.1	111	138	164	185	0.83
						K _V	0.00	12.2	23.7	34.9	46.5	59.1	75.3	96.0	119	142	160	---
						X _T	---	0.519	0.592	0.592	0.595	0.591	0.592	0.593	0.593	0.593	0.593	---
4	111.1	4.375	51	2	R to L	C _V	234	231	225	216	200	175	140	103	65.2	30.0	0	0.87
						K _V	202	200	195	187	173	151	121	89.1	56.4	25.9	0.00	---
						X _T	0.727	0.698	0.702	0.685	0.672	0.670	0.692	0.657	0.548	0.583	---	---
					B to L	C _V	0	2.81	11.9	25.0	43.1	69.0	106	149	200	256	312	0.84
						K _V	0.00	2.43	10.3	21.6	37.3	59.7	91.7	129	173	221	270	---
						X _T	---	0.754	0.866	0.805	0.747	0.725	0.729	0.715	0.695	0.659	0.590	---
6	177.8	7	51	2	R to L	C _V	413	386	363	331	296	252	207	157	102	49.5	0	0.87
						K _V	357	334	314	286	256	218	179	136	88	42.8	0.00	---
						X _T	0.770	0.764	0.729	0.716	0.699	0.665	0.607	0.537	0.488	0.465	---	---
					B to L	C _V	0	38.4	70.1	110	156	208	262	324	393	473	556	0.84
						K _V	0.00	33.2	60.6	95.2	135	180	227	280	340	409	481	---
						X _T	---	0.750	0.789	0.770	0.738	0.720	0.708	0.707	0.694	0.654	0.605	---

1. The end connections are identified on the valve body.
2. At maximum flow.

YD and YS Valves

Table 14. Fisher YS, Diverging Flow

Diverging Flow								On-Off Service Only	
Valve Size, NPS	Port Diameter		Maximum Travel		Flow Path ⁽¹⁾	Flow Coefficient	Valve Opening—Percent of Total Travel		F _L ⁽²⁾
	mm	Inches	mm	Inches			0 (Plug Down)	100 (Plug Up)	
1/2	33.3	1.3125	19	0.75	L to R	C _v	8.20	0	0.84
						K _v	7.09	0.00	---
						X _T	0.612	---	---
					L to B	C _v	0	8.89	0.82
						K _v	0.00	7.69	---
						X _T	---	0.544	---
3/4	33.3	1.3125	19	0.75	L to R	C _v	11.0	0	0.84
						K _v	9.52	0.00	---
						X _T	0.616	---	---
					L to B	C _v	0	11.8	0.81
						K _v	0.00	10.2	---
						X _T	---	0.597	---
1	33.3	1.3125	19	0.75	L to R	C _v	17.1	0	0.94
						K _v	14.8	0.00	---
						X _T	0.742	---	---
					L to B	C _v	0	19.3	0.89
						K _v	0.00	16.7	---
						X _T	---	0.696	---
1-1/2	33.3	1.3125	19	0.75	L to R	C _v	20.5	0	0.89
						K _v	17.7	0.00	---
						X _T	0.590	---	---
					L to B	C _v	0	23.2	0.85
						K _v	0.00	20.1	---
						X _T	---	0.550	---
2	58.7	2.3125	29	1.125	L to R	C _v	58.1	0	0.94
						K _v	50.3	0.00	---
						X _T	0.848	---	---
					L to B	C _v	0	72.7	0.93
						K _v	0.00	62.9	---
						X _T	---	0.757	---
2-1/2	58.7	2.3125	29	1.125	L to R	C _v	64.0	0	0.92
						K _v	55.4	0.00	---
						X _T	0.772	---	---
					L to B	C _v	0	80.0	0.91
						K _v	0.00	69.2	---
						X _T	---	0.691	---

-continued-

Product Bulletin

51.1:YD
April 2010

YD and YS Valves

Table 14. Fisher YS, Diverging Flow (continued)

Valve Size, NPS	Port Diameter		Maximum Travel		Flow Path ⁽¹⁾	Flow Coefficient	Valve Opening—Percent of Total Travel		F _L ⁽²⁾
	mm	Inches	mm	Inches			0 (Plug Down)	100 (Plug Up)	
3	87.3	3.4375	38	1.5	L to R	C _v	118	0	0.93
						K _v	102	0.00	---
						X _T	0.830	---	---
					L to B	C _v	0	148	0.95
						K _v	0.00	128	---
						X _T	---	0.766	---
4	111.1	4.375	51	2	L to R	C _v	203	0	0.92
						K _v	176	0.00	---
						X _T	0.819	---	---
					L to B	C _v	0	265	0.94
						K _v	0.00	229	---
						X _T	---	0.757	---
6	177.8	7	51	2	L to R	C _v	386	0	0.94
						K _v	334	0.00	---
						X _T	0.849	---	---
					L to B	C _v	0	512	0.94
						K _v	0.00	443	---
						X _T	---	0.772	---

1. The end connections are identified on the valve body.
2. At maximum flow.

Specifications

Valve Sizes, Ratings, and End Connections ^(1,2)

Cast Iron Valves.

Flanged: NPS 1 through 6 CL125 flat-face or 250 raised-face flanges per ASME B16.1

Screwed: NPS 1/2 through 2 consistent with ASME B16.4

Steel and Stainless Steel Valves.

Flanged: NPS 1 through 8 CL150, 300, and 600 raised-face or ring-type joint flanges per ASME B16.5

Screwed or Socket Welding: NPS 1/2 through 2 consistent with ASME B16.11

Buttwelding: NPS 1 through 6. All available ASME B16.25 schedules that are consistent with ASME B16.34

Maximum Inlet Pressures and Temperatures ⁽¹⁾⁽²⁾

As listed below, unless limited by maximum pressure drop or material temperature capabilities.

Cast Iron Valves.

Flanged: Consistent with CL125B or 250B per ASME B16.1

Screwed: Consistent with flanged CL250 per ASME B16.4

Steel and Stainless Steel Valves.

Flanged: Consistent with CL150, 300, and 600⁽³⁾ per ASME B16.34

Screwed or Welding: Consistent with flanged CL600⁽³⁾ per ASME B16.34

Operative Pressure/Temperature Limits ^(1, 2)

Pressure Drop Limit Due to Gasket Loading:

See table 1.

Shutoff Pressure Drop Limits with Typical Actuators:

See tables 6, 7, and 8.

Pressures and Temperatures for Trims Only:

See figure 7.

Temperatures for Body-Trim Combinations:

See table 5.

Temperatures for All Other Parts:

See table 3.

Shutoff Classifications per ANSI/FCI 70-2 and IEC 60534-4

YD.

Standard Design: Class IV

High-Temperature Design: Class II

YS.

Standard Class: Class IV

Optional Class: Class V

Flow Characteristic

Linear

Flow Direction

See figure 6

Flow Coefficients and Noise Level Prediction

Refer to the section titled Coefficients in this bulletin and Catalog 12

Valve Plug Styles

YD: Balanced, metal-seated

YS: Unbalanced, metal-seated

Rated Travels and Port Diameters

See table 1

Yoke Boss and Stem Diameters for Actuator Mounting

VALVE SIZE, NPS	VALVE STEM AND YOKE BOSS DIAMETERS, INCHES			
	Standard		Optional	
	Yoke Boss	Stem	Yoke Boss	Stem
mm				
1/2, 3/4, 1, 1-1/2	54	9.5	71	12.7
2, 2-1/2, 3, 4	71	12.7	90	19.1
6	90	19.1	127	25.4
8	90	19.1	---	---
Inch				
1/2, 3/4, 1, 1-1/2	2-1/8	3/8	2-13/16	1/2
2, 2-1/2, 3, 4	2-13/16	1/2	3-9/16	3/4
6	3-9/16	3/4	5	1
8	3-9/16	3/4	---	---

- continued -

Specifications (continued)

Actuator Sizing

See tables 6, 7, and 8

Bonnet Styles

See table 10

Construction Materials

Valve Body and Bonnet: ■ Cast iron (except extension bonnet), ■ WCC steel, ■ WC9 chrome moly steel, or ■ CF8M (316 SST)

Trims: See table 2.

All Other Parts: See table 3

Approximate Shipping Weights

VALVE SIZE, NPS	SHIPPING WEIGHT	
	kg	lb
1/2, 3/4	14	30
1	18	40
1-1/2	27	60
2	39	85
2-1/2	50	110
3	68	150
4	109	240
6	227	500
8	345	760

Options

- Lubricator or lubricator/isolating valve for packing lubrication
- Drilled and tapped connection in extension bonnet for leakoff
- ENVIRO-SEAL live-loaded packing systems⁽⁴⁾

1. PN (or other) ratings and end connections can usually be supplied; consult your Emerson Process Management sales office.
 2. The pressure or temperature limits in this bulletin and any applicable standard limitations should not be exceeded. OPERATIVE LIMITS term is defined in SAMA Standard PMC 20.1.
 3. Certain bonnet bolting material selections may require a CL600 easy-e valve assembly to be derated. Contact your Emerson Process Management sales office for more information.
 4. For additional information, see Bulletin 59.1:061 ENVIRO-SEAL and HIGH-SEAL Packing Systems for Sliding-Stem Valves.

ENVIRO-SEAL Packing System Specifications

Applicable Stem Diameters

■ 9.5 mm (3/8 inches), ■ 12.7 (1/2), ■ 19.1 (3/4), and ■ 25.4 (1) diameter valve stems

Maximum Pressure/Temperature Limits⁽¹⁾

To Meet the EPA Fugitive Emission Standard of 100 PPM⁽²⁾.

For ENVIRO-SEAL PTFE and ENVIRO-SEAL Duplex packing systems: full CL300 up to 232°C (450°F)

For ENVIRO-SEAL Graphite ULF packing system: 104 bar (1500 psig) at 316°C (600°F)

Construction Materials

PTFE Packing Systems.

Packing Ring and Lower Wiper: PTFE V-ring⁽³⁾.

Male and Female Adaptor Rings: Carbon-filled

PTFE V-ring

Anti-Extrusion Washer: Filled PTFE

Lantern Ring: S31600 (316 stainless steel)

Spring: ■ 17-7PH stainless steel or ■ N06600

Packing Box Flange: S31600

Packing Follower: S31600 lined with carbon-filled PTFE

Packing Box Studs: SA193-B8M Class 2

Packing Box Nuts: S31600

Graphite ULF Packing Systems.

Packing Ring: Graphite rings

Spring: ■ 17-7PH stainless steel or ■ N06600

Packing Box Flange: S31600

Packing Follower: S31600 lined with carbon-filled PTFE

Packing Box Studs: SA193-B8M Class 2

Packing Box Nuts: S31600

1. Refer to the valve specifications in this bulletin for pressure/temperature limits of valve parts. Do not exceed the pressure/temperature rating of the valve. Do not exceed any applicable code or standard limitation.

2. The Environmental Protection Agency (EPA) has set a limit of 100 parts per million (ppm) for fugitive emissions from a valve in selected VOC (Volatile Organic Compound) services.

3. In vacuum service, reversing the ENVIRO-SEAL PTFE packing rings is not necessary.

Note

Neither Emerson, Emerson Process Management, nor any of their affiliated entities assumes responsibility for the selection, use, or maintenance of any product. Responsibility for the selection, use, and maintenance of any product remains with the purchaser and end user.

Fisher, easy-e, and ENVIRO-SEAL are marks owned by one of the companies in the Emerson Process Management business division of Emerson Electric Co. Emerson Process Management, Emerson, and the Emerson logo are trademarks and service marks of Emerson Electric Co. All other marks are the property of their respective owners.

The contents of this publication are presented for informational purposes only, and while every effort has been made to ensure their accuracy, they are not to be construed as warranties or guarantees, express or implied, regarding the products or services described herein or their use or applicability. All sales are governed by our terms and conditions, which are available upon request. We reserve the right to modify or improve the designs or specifications of such products at any time without notice. Neither Emerson, Emerson Process Management, nor any of their affiliated entities assumes responsibility for the selection, use or maintenance of any product. Responsibility for proper selection, use, and maintenance of any product remains solely with the purchaser and end user.

Emerson Process Management

Marshalltown, Iowa 50158 USA

Sorocaba, 18087 Brazil

Chatham, Kent ME4 4QZ UK

Dubai, United Arab Emirates

Singapore 128461 Singapore

www.Fisher.com

