

**Product Bulletin**

51.6:edisc (EMA)  
D100066X012  
February 2007

**8510/8510B Valve**

# Fisher<sup>®</sup> 8510 and 8510B Eccentric Disc Control Valves (EMA)

Fisher 8510 and 8510B eccentric disc valves feature an eccentrically mounted disc and a PTFE or 316 stainless steel seal ring. The pressure-assisted seal ring provides excellent shutoff against pressure applied in either direction. The 8510B is a multi-class rated valve, available in NPS 2 through 12, and PN10 through PN100 compatible (compatibility varies with size and class, see table 1).

The 8510 is rated for CL150, available in NPS 14 through 24, and PN10 and PN16 compatible

(compatibility varies with size and class, see table 1). These valves combine with a variety of power and manual actuators to form reliable, high-performance control valves suited for many liquid and gas applications requiring extremely low leakage. Constructions are available for temperatures up to 538°C (1000°F).

Unless otherwise noted, all NACE references are to NACE MR0175-2002.

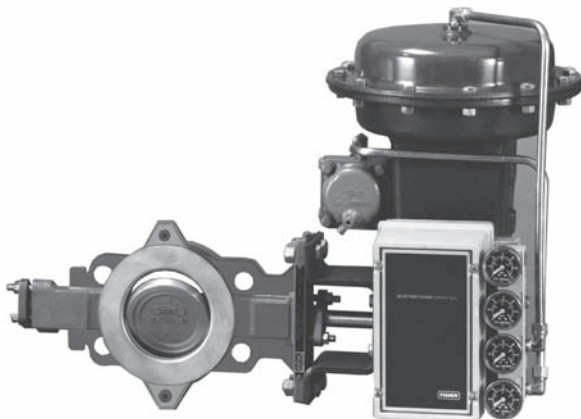

W4739-2/IL

Figure 1. Eccentric Disc Control Valve with Fisher 1052 Actuator and 3610J Positioner



W9264-1

Figure 2. Fisher 8510B with Alternate Double D Shaft and 1035/EI-O-Matic Actuator



## Specifications

### Valve Sizes and End Connection Style

**8510B:** NPS ■ 2, ■ 4, ■ 6 and ■ 8 (PN10 through PN100) – CL150, 300 or 600 ASME flange compatibility, ■ 10 and ■ 12 (PN10 through PN40) – CL150 ASME flange compatibility

**8510 flangeless valves:** NPS ■ 14 (PN10 and PN16), ■ 16 (PN16), ■ 18, ■ 20 (PN16) and ■ 24 (PN16) – CL150 ASME flange compatibility for NPS 14 through 24

Also see table 1.

### Maximum Inlet Pressures<sup>(1)</sup>

**WCC Steel, CF3M Stainless Steel (316L SST), and CN7M (Alloy 20) Valve Bodies:** Consistent with applicable pressure-temperature ratings in table 2, unless limited by pressure drop/temperature capabilities in tables 6, 7, 8, 9 and 10 or temperature capabilities in table 11.

**M35-1 Valve Bodies:** As shown in table 2, unless further limited by pressure drop/temperature capabilities in table 10 or temperature capabilities in table 11.

### Maximum Pressure Drops<sup>(1)</sup>

**Steel Valve Bodies (8510 and 8510B):** See table 6 or 7.

**CF8M Stainless Steel Valve Bodies (8510):** See tables 8 and 9.

**Alloy Valve Bodies (8510B):** See table 10.

### Shutoff Classifications per ANSI/FCI 70-2 and IEC 60534-4

**PTFE Seal Ring:** Bidirectional shutoff to Class VI is standard

**316 Stainless Steel Seal Ring:** 0.001% of maximum valve capacity (one tenth of Class IV)

### Construction Materials

See tables 3, 4 and 5

### Material Temperature Capabilities<sup>(1)</sup>

See table 11

### Flow Characteristic

Approximately linear

### Flow Direction

Standard (forward flow) is with the seal retainer facing upstream; reverse flow is permissible within specified limitations

### Flow Coefficients

See table 1

### Flow Coefficient Ratio<sup>(2)</sup>

100 to 1

### Noise Levels

See Catalog 12 for sound pressure level prediction

### Disc Rotation

Clockwise to close (when viewed from actuator side of valve) through 90 degrees of disc rotation

### Actuator Valve Action

With diaphragm or piston rotary actuator, field-reversible between ■ push-down-to-open (extending actuator rod opens valve) and ■ push-down-to-close (extending actuator rod closes valve)

With 1035 Rack and Pinion actuator with spring return or double acting action, field-reversible between ■ fail-to-open and ■ fail-to-close

### Valve Classification

■ Face-to-face dimensions of NPS 3 through 6 in CL150 and 300, and face-to-face dimensions of NPS 8 through 24 in CL150, meet API 609 standards for face-to-face dimensions of narrow flangeless and single-flange valves

■ DIN face-to-face dimensions for all sizes meet DIN 3202 Part 3/K2, and

■ JIS B2210 standard face-to-face dimensions are available on request.

(continued)

**Specifications (continued)**

**Mating Flange Capabilities**

All size compatible with welding-neck and slip-on flanges (schedule 80 or lighter for 8510B NPS 2 through 12; schedule 40 or lighter for 8510 NPS 14 through 24)

**Shaft Diameters and Approximate Weights**

See figures 9 and 10

**Options**

- Line flange bolting, ■ FGM line flange gaskets

1. The pressure/temperature limits in this bulletin and any applicable standard or code limitation should not be exceeded.  
2. Ratio of maximum flow coefficient to minimum useable flow coefficient.

**Features**

- **Sour Service Capability**—Materials are available for applications involving sour service. These materials comply with the requirements of NACE MR0175-2002.

- **Excellent Flow Control**—The eccentrically mounted disc design provides an approximately linear flow characteristic and can be used for on/off or throttling control applications through 90 degrees of disc rotation. Optional disc stop on 8510B provides seal protection.

- **Improved Environmental Capabilities**—The optional ENVIRO-SEAL™ packing systems, shown in figure 8, are designed with very smooth stem surfaces, and live loading provides improved

sealing, guiding, and loading force transmission. The seal of the ENVIRO-SEAL system can control emissions to below the EPA (Environmental Protection Agency) limit of 100 ppm (parts per million) for valves.

- **Lost Motion Minimized**—For 8510, the taper pin/disc connection and the splined valve shaft with clamped lever and single pivot linkage reduce lost motion between the actuator and valve. For 8510B, the taper key/disc connection and the splined valve shaft with clamped lever and single pivot linkage reduce lost motion between the actuator and valve.

- **Greater Capacities and Lower Operating Torques**—The contoured disc increases flow capacity and reduces operating torque at peak angles of disc opening.

## ENVIRO-SEAL Packing System Specifications

### Available Packing

- ENVIRO-SEAL PTFE Packing System
- ENVIRO-SEAL Graphite Packing System

### Maximum Temperature/Pressure Limits<sup>(1)</sup>

#### Maximum Application Temperature/Pressure Limits to meet EPA Fugitive Emission Standard of 100 ppm<sup>(2)</sup>:

*For ENVIRO-SEAL PTFE Packing Systems:* Up to 232°C (450°F) at the ASME class rating of the valve.

*For ENVIRO-SEAL Graphite Packing Systems:* Up to 316°C (600°F) at the ASME class rating of the valve

#### Material Temperature Range:

*For ENVIRO-SEAL PTFE Packing Material:*  
-46 to 232°C (-50 to 450°F)

*For ENVIRO-SEAL Graphite Packing Material:*  
Up to 316°C (600°F)

### Construction Materials<sup>(3)</sup>

#### PTFE Packing Systems:

*Packing Rings:* PTFE V-ring<sup>(4)</sup>.

*Male and Female Adaptor Rings:* Carbon-filled PTFE V-ring

*Anti-Extrusion Rings:* High strength polymer

*Packing Box Rings:* S31600 (316 SST)

#### Graphite Packing Systems:

*Packing Rings:* Graphite

*Anti-Extrusion Rings:* Carbon

*Packing Box Rings:* S31600 (316 SST)

#### Spring Pack Components:

*O-Ring:* Nitrile. The O-ring serves as an assembly convenience to hold the springs in position on the follower.

*Packing Follower:* S31600 with carbon-filled PTFE liner

*Springs:* N07718

*Packing Flange:* S31600 (316 SST)

*Packing Box Studs:* Strain-hardened S31600, SA-193-B8M

*Packing Box Nuts:* S31600 SA-194-8M

1. The pressure/temperature limits in this bulletin and any applicable standard or code limitation for valve should not be exceeded.

2. The Environmental Protection Agency (EPA) has set a limit of 100 parts per million (ppm) for fugitive emissions from a valve.

3. For other materials of construction, see table 3.

4. In vacuum service it is not necessary to reverse the ENVIRO-SEAL PTFE packing rings.

## Construction Features

- **Field-Reversible Valve Action**—The actuator/valve assembly action can be converted from push-down-to-open to push-down-to-close, or vice versa, without additional parts.
- **Integral Shaft-to-Body Bonding**—Standard valve construction includes conductive packing to provide electrical bonding for hazardous area applications.
- **Easy Installation**—Centering holes (figures 3, 4 and 5) engage the line flange bolts to simplify installation and provide for centering of the valve in the pipeline.
- **Long Seal Life**—The opening and closing path of the eccentric disc (figure 6) minimizes disc contact with the seal ring, thereby reducing seal wear, undue friction, and seating torque requirements.
- **Exceptional Shutoff at High Pressure Drops**—Both the 316 stainless steel seal ring and the bidirectional PTFE seal ring with

pressure-assisting sealing action (figure 7) are designed to provide shutoff regardless of flow direction.

- **Reliable Flange Gasketing Surface**—The seal retainer cap screws or retention clips are outside the gasket surface of the seal retainer, and spiral wound or flat sheet gaskets can be installed between the uninterrupted seal retainer face and the pipeline flange.

- **Self-Flushing Action**—With standard right-hand actuator mounting, the bottom edge of the disc opens downstream away from the seal, and the flow stream flushes sediment from the seal.

- **Double D Shaft**—8510B valves in NPS 2 through 12 are available with double D shaft end designed to accept the 1035 Rack and Pinion Actuator and other quarter-turn actuators.

- **Shaft Retention**—Redundant shaft protection is provided with 8510B valves with the double D drive shaft. The packing follower and stepped shaft interact to provide the redundant shaft retention.

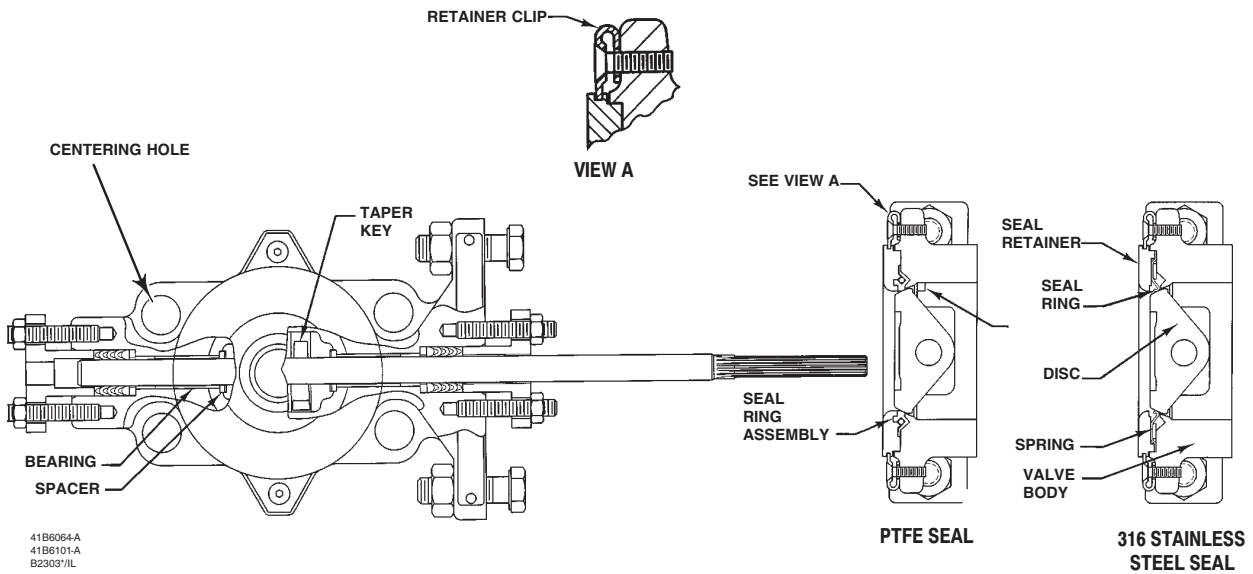

Figure 3. Typical Fisher 8510B Construction Detail

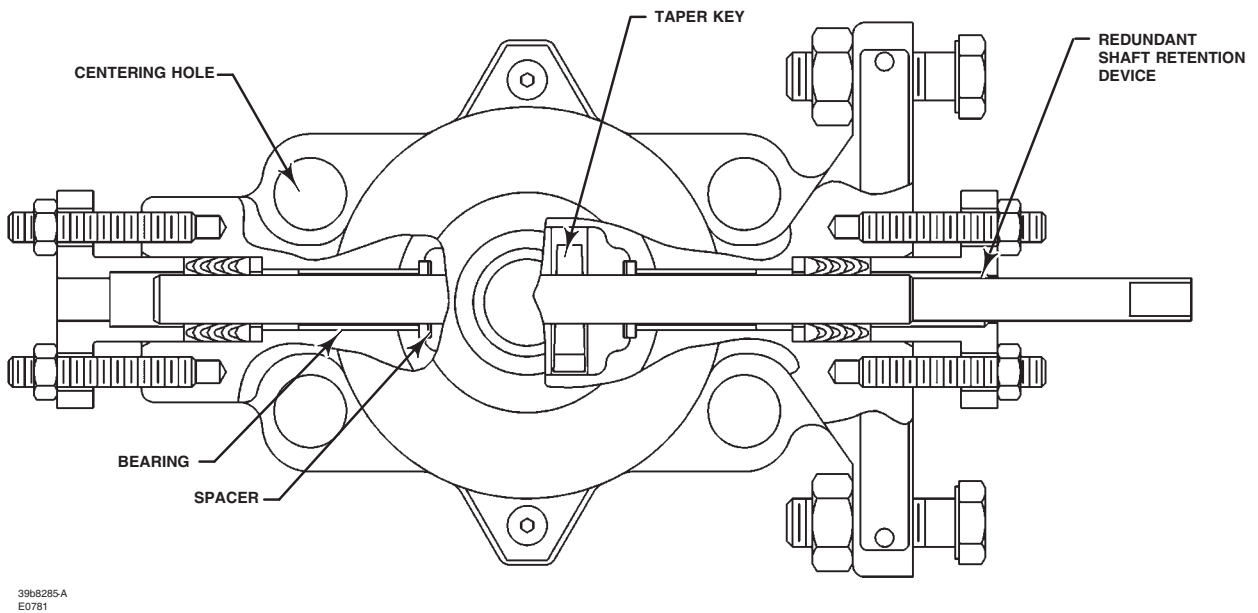

Figure 4. Typical Fisher 8510B Construction Detail with Double D Shaft

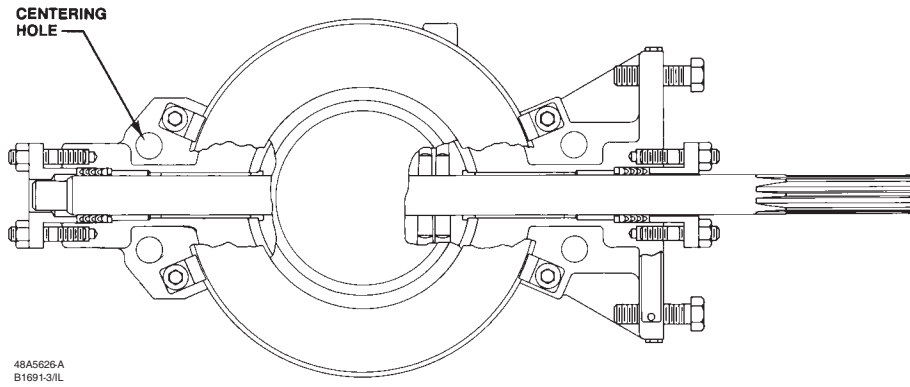

Figure 5. Construction of Fisher 8510

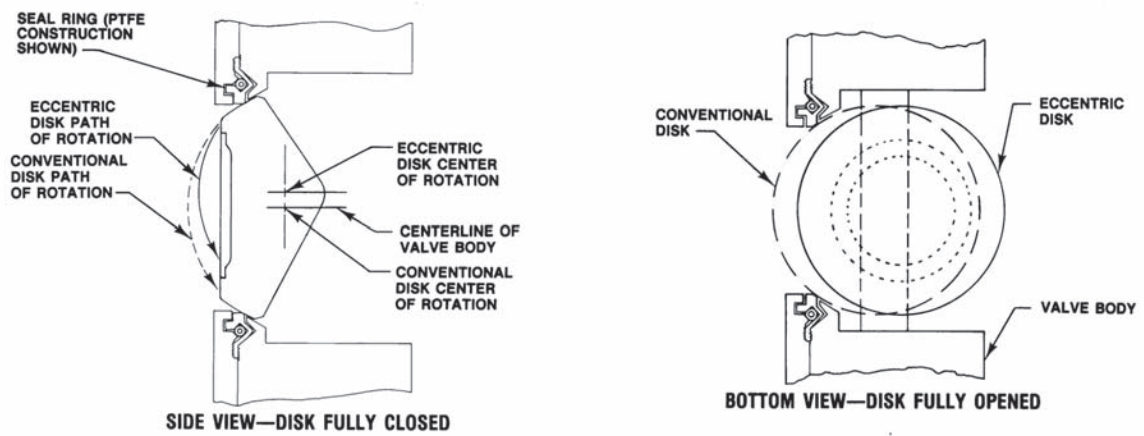

Figure 6. Comparison of Disc Action

**Product Bulletin**

51.6:edisc (EMA)

February 2007

**8510/8510B Valve**

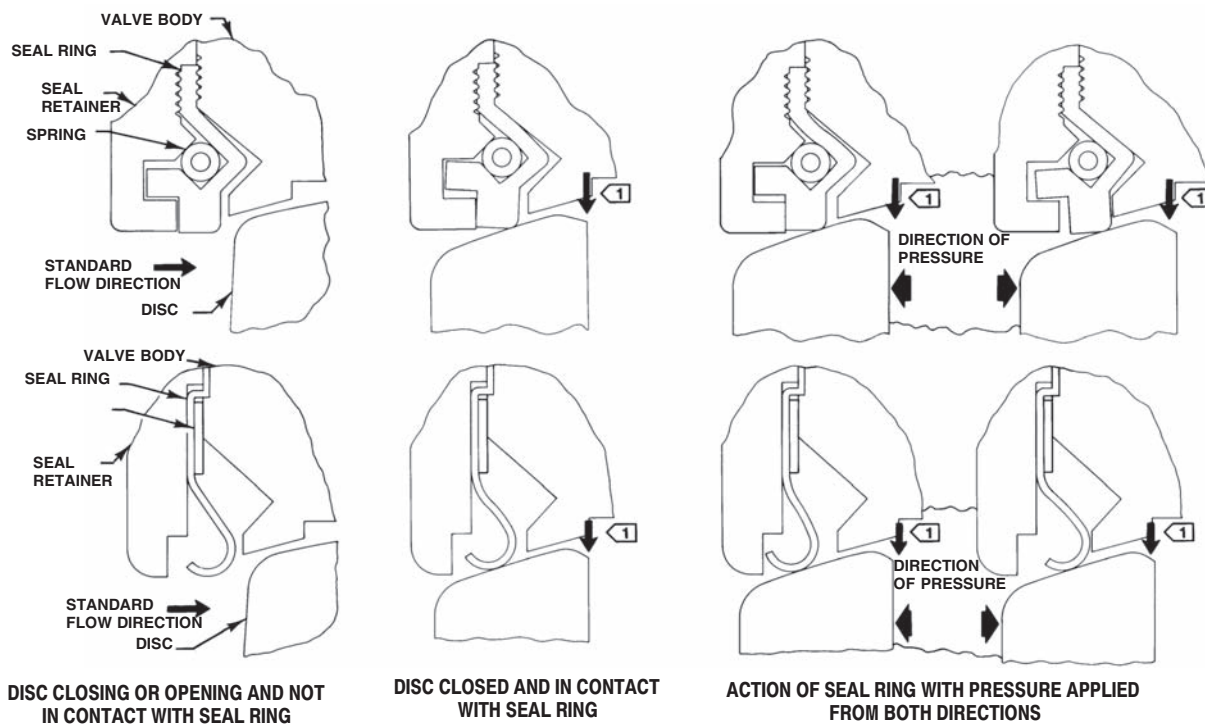

**NOTE:**

1 ARROW INDICATES DISC POSITION WITH NO PRESSURE

B1558-3/IL

Figure 7. Action of Bidirectional PTFE Seal Ring (Top) and Metal Seat Ring (Bottom)

# 8510/8510B Valve

Table 1. Flow Coefficients and ASME Rating and Flange Compatibility

VALVE BODY SIZE, NPS	C <sub>v</sub> WITH NORMAL FLOW AND DISC WIDE OPEN (90 DEGREES ROTATION)	ASME RATING COMPATIBILITY—STEEL, STAINLESS STEEL, AND ALLOY 20 VALVE BODIES	VALVE DESIGNATION—M35-1 <sup>(1)</sup>	ASME FLANGE COMPATIBILITY	PN FLANGE COMPATIBILITY
<b>8510B</b>					
2	91.7	CL150, 300, and 600	CL150/300/600	CL150, 300, and 600	PN10, PN16, PN25, PN40, PN63 and PN100
3	232				
4	459				
6	907				
8	1740				
10	3570	CL150 CL300	CL150 CL300	CL150 CL300	PN10 and PN16 PN25 and PN40
12	4880	CL150 CL300	CL150 CL300	CL150 CL300	PN10 and PN16 PN25 and PN40
<b>8510</b>					
14	7040	CL150	---	CL150	PN10 and PN16 <sup>(2)</sup>
16	9650				PN16 <sup>(2)</sup>
18	12,100				---
20	14,500				PN16 <sup>(2)</sup>
24	21,800				PN16 <sup>(2)</sup>
<p>1. M35-1 valve bodies are not included in ASME B16.34. See table 2 for pressure/temperature information for M35-1 valve bodies. The designations CL150, 300, and 600 for these valve bodies are used only to indicate relative pressure-retaining capabilities and are not ASME pressure/temperature rating class designations.</p> <p>2. Consult your Emerson Process Management™ sales office for pressure/temperature ratings of these valves.</p>					

Table 2. Maximum Allowable Inlet Pressures for M35-1 Valve Bodies<sup>(1)</sup>

TEMPERATURE	M35-1 <sup>(1)</sup>		
	150 <sup>(1)</sup>	300 <sup>(1)</sup>	600 <sup>(1)</sup>
°C	Bar		
-46 to 38	15.8	41.3	82.7
93	13.8	36.5	72.7
149	13.1	34.1	68.2
204	12.7	33.1	65.8
232	12.3	33.0	65.7
°F	Psig		
-50 to 100	230	600	1200
200	200	530	1055
300	190	495	990
400	185	480	955
450	178	478	953
<p>1. This material is not listed in ASME B16.34. Also see the installation information. The designations CL150, 300, and 600 are used only to indicate relative pressure-retaining capabilities and are not ASME pressure-temperature rating class designations.</p>			

# Product Bulletin

51.6:edisc (EMA)  
February 2007

# 8510/8510B Valve

Table 3. Standard Construction Materials

Part		Material
Valve Body <sup>(1)</sup>		<b>8510:</b> WCC Steel, CG8M (316 stainless steel), M35-1 <sup>(2)</sup> , or CN-7M (alloy 20) <b>8510B:</b> WCC Steel, CF3M (316L SST), M35-1 <sup>(2)</sup> , CN7M (alloy 20), 1.0619 steel, or 1.4581 stainless steel
Disc <sup>(1)</sup>		<b>8510:</b> WCC Steel (A216), S31603 (316L stainless steel) (both with chrome-plated seating surfaces), M35-1, or alloy 20 CN-7M <b>8510B:</b> WCC Steel (A216), M35-1, CN7M (alloy 20), S31603 (316L SST), or Cr PI S31603 (Cr PI 316L SST)
Seal <sup>(1)</sup>		PTFE with 316 stainless steel, N04400, or alloy 20 spring
		316 stainless steel seal and backup rings with graphite gaskets bonded to them
Bearings <sup>(1)</sup>	Lined	<b>8510:</b> PTFE <sup>(3)</sup> /composition lined w/SST jacket, PTFE <sup>(3)</sup> composition lined w/S31600 (316 SST) jacket, S44004 (440C SST), alloy 6B, silver-plated alloy 6B, filled PTFE <sup>(4)</sup> w/N04400 jacket, or filled PTFE <sup>(4)</sup> w/N08020 (alloy 20) jacket <b>8510B:</b> PTFE <sup>(3)</sup> /composition lining with S31603 (316L SST), PTFE <sup>(4)</sup> with S31603 jacket, filled PTFE <sup>(4)</sup> with N04400 jacket, and filled PTFE <sup>(4)</sup> with N08020 (alloy 20) jacket
	All-metal	440C stainless steel, alloy 6B, or silver-plated alloy 6B
<b>8510:</b> Valve shaft <sup>(1)</sup> and bearing spacers		S17400 (17-4PH SST), S20910, N04400, or alloy 20
<b>8510B:</b> Valve Shaft <sup>(1)(6)</sup>		S17400 (17-4PH), S20910, N05500, N08020 (alloy 20), or S31603 (316L SST)
<b>8510B:</b> Bearing Spacers		PTFE/S31603 (316L SST), S17700 (17-7 PH SST), alloy 6B, PTFE/N04400, and PTFE/N08020 (alloy 20)
<b>8510:</b> Taper Pins <b>8510B:</b> Taper Keys	S17400 (17-4PH) and S20910 shafts	<b>8510:</b> S20910 <b>8510B:</b> S20910 SST, N05500, N10276 (alloy 276), or N08020 (alloy 20)
	Alloy shafts	Same material as shaft
<b>8510:</b> Bearing stops (for metal bearings and non-alloy valve bodies only)	Steel valve bodies	S17400
	CF8M steel valve bodies	S31600 (316 stainless steel)
<b>8510B:</b> Bearings stops (for metal bearings and non-alloy valves only)		S31600 (316 SST)
Seal retainer		Same material as valve body
Packing arrangements		Standard packing is available with PTFE packing V-rings with one carbon-filled PTFE conductive ring, PTFE-composition rings with one graphited conductive ring, and preformed graphite ribbon rings. ENVIRO-SEAL packing system is available with PTFE V-rings with one carbon-filled PTFE conductive ring or with graphite packing rings.
Packing followers and packing box rings		S31600, N04400, or alloy 20
Packing flanges, studs and nuts		Plated steel, S31603 <sup>(5)</sup> , S31600, CF8M, N04400, or alloy 20

1. See table 4 for acceptable trim material combinations.  
2. This is not an ASME B16.34 or ASME code-approved material. Also see the Installation section.  
3. Reinforced PTFE in phenolic resin, Emerson Process Management designation is FMS 30B4.  
4. PTFE with selected fillers. Emerson Process Management designation is FMS 30B5.  
5. S31603 is available for 8510B only  
6. 8510B valve shafts with Double D end are available only in 17-4PH SST, 316L SST or S20910.

# 8510/8510B Valve

Table 4. Trim Combinations with Standard Construction Materials

Disc Material	Shaft Material	Bearing Material	Seal Material	Acceptable Valve Body Material	Trim Number
<b>8510:</b> WCC steel with chrome-plated seating surfaces  <b>8510B:</b> WCC steel with chrome-plated seating surface or S31603 (316L SST) <sup>(1)</sup>	S17400 (17-4PH stainless steel)	PTFE/composition-lined, w/SST jacket	PTFE	Steel	1
			316 stainless steel		5
		S44004 (440C SST)	316 stainless steel		9
<b>8510:</b> S31603 (316L SST) with chrome-plated seating surfaces  <b>8510B:</b> S31603 (316L SST) with chrome-plated seating surfaces or S31603 (316L SST) without plating with PTFE seal only	S17400	PTFE/composition-lined w/SST jacket	PTFE	Steel	2
			316 stainless steel		6
		PTFE/composition-lined S31600 (316 SST) jacket	PTFE	<b>8510:</b> Steel or CF8M <b>8510B:</b> Steel or CF3M (316 SST)	4
			316 stainless steel		8
		S44004	316 stainless steel	Steel	10
		Silver-plated alloy 6B	316 stainless steel	<b>8510:</b> Steel or, CF8M <b>8510B:</b> Steel or CF3M (316 SST)	12
	Alloy 6B	316 stainless steel	14		
	S20910	PTFE/composition-lined with S31600 jacket	PTFE	<b>8510:</b> Steel or CF8M <b>8510B:</b> Steel or CF3M (316 SST)	3
			316 stainless steel		7
		Silver-plated alloy 6B	316 stainless steel		11
	Alloy 6B	316 stainless steel		13	
M35-1	N05500	Filled PTFE <sup>(2)</sup> w/ N04400 jacket	PTFE	M35-1 or steel	15 <sup>(3)</sup>
Alloy 20 CN7M	Alloy 20	Filled PTFE <sup>(2)</sup> w/ N08020 (alloy 20) jacket	PTFE	Alloy 20 CN-7M	17 <sup>(3)(4)</sup>

1. Steel disc not available in the NPS 2 and 3 valves.  
 2. PTFE with selected fillers, Emerson Process Management designation is FMS 30B5.  
 3. This trim not available in the 8510 NPS 14 through 24 valves.  
 4. This trim not available with the Double D shaft version of the 8510B.

Table 5. Trim NT3 Part Materials for Compliance with NACE MR0175-2002 (Sour Service) Specifications

Valve Body	Disc	Seal	Bearings	Valve Shaft	Taper Pins	Packing	Packing Followers and Packing Box Rings	Packing Flanges	Packing Flange Bolting
<b>8510:</b> Steel or CF8M (316 stainless steel)  <b>8510B:</b> Steel or CF3M (316L SST)	<b>8510:</b> CG8M (317 stainless steel) with chrome-plated seating surfaces  <b>8510B:</b> S31603 (316 SST) with chrome-plated seating surfaces or S31603 (316L SST)	PTFE seal with N05500 spring	<b>8510:</b> Filled PTFE w/ S31600 (316 SST) jacket  <b>8510B:</b> PTFE/composition-lined S31603 (316L SST)	S20910	S20910	PTFE V-ring with one carbon-filled PTFE conductive packing ring	<b>8510:</b> S31600 (316 stainless steel)  <b>8510B:</b> S31600 (316 SST) or S31603 (316L SST)	<b>8510:</b> steel  <b>8510B:</b> S31600 (316 SST) or S31603 (316L SST)	Grade B7 steel studs and Grade 2H steel nuts

# Product Bulletin

51.6:edisc (EMA)

February 2007

# 8510/8510B Valve

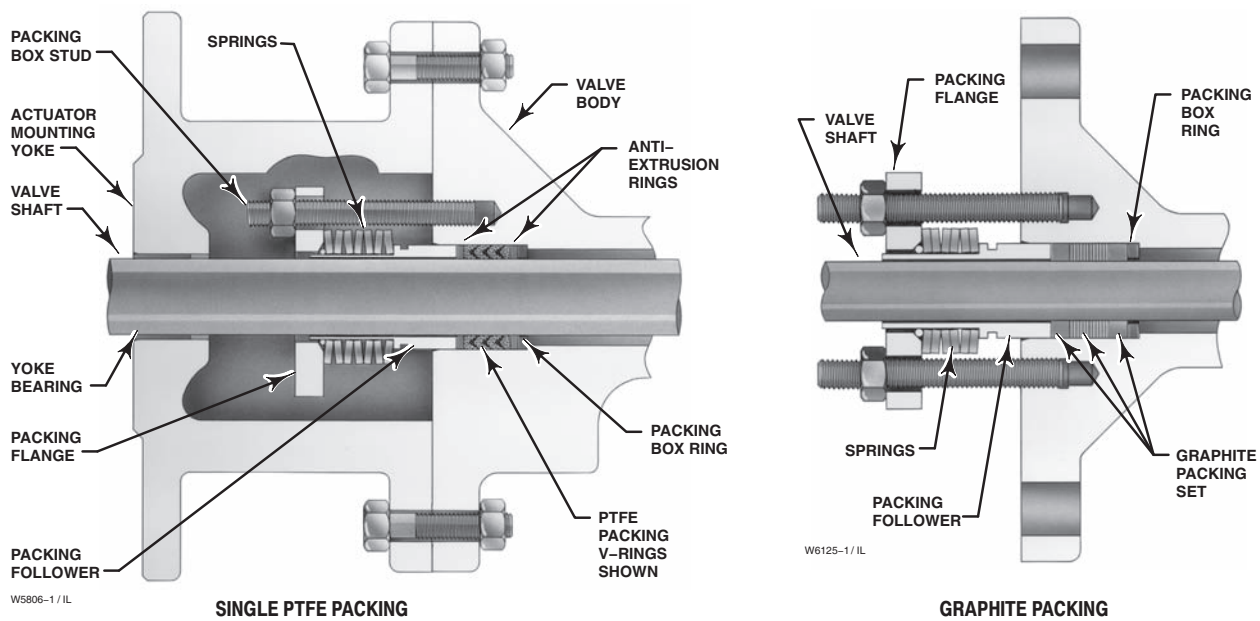

Figure 8. Typical ENVIRO-SEAL Packing Arrangements for Rotary Valves

# 8510/8510B Valve

Product Bulletin  
51.6:edisc (EMA)  
February 2007

Table 6. Maximum Allowable Shutoff Pressure Drops<sup>(1)</sup> in Bar for Steel Valve Body Material

TABLE 4 OR 5 TRIM NUMBER	FLOW DIRECTION	TEMP. °C	MAX ALLOWABLE SHUTOFF ΔP (PER VALVE BODY SIZE, NPS)												
			8510B						8510						
			2	3	4	6	8	10	12	14	16	18	20	24	
1 <sup>(2)</sup> , 2, 3, 4, NT3	Forward or reverse	-29 to 49	56.2	64.5	53.8	57.9	54.6	37.7	41.4	19.7	19.7	19.7	19.7	19.7	
		66	56.2	58.5	53.8	57.9	54.6	37.7	41.4	19.0	19.0	19.0	19.0	19.0	
		93	48.5	48.5	48.5	48.5	48.5	37.7	41.4	17.9	17.9	17.9	17.9	17.9	
		121	38.6	38.6	38.6	38.6	38.6	37.7	38.6	16.9	16.9	16.9	16.9	16.9	
		149	28.7	28.7	28.7	28.7	28.7	28.7	28.7	15.5	15.5	15.5	15.5	15.5	
		191	13.8	13.8	13.8	13.8	13.8	13.8	13.8	13.8	13.8	13.8	13.8	13.8	13.8
		204	10.3	10.3	10.3	10.3	10.3	10.3	10.3	10.3	10.3	10.3	10.3	10.3	10.3
		232 <sup>(3)</sup>	3.4	3.4	3.4	3.4	3.4	3.4	3.4	3.4	3.4	3.4	3.4	3.4	
5 <sup>(2)</sup> , 6, 7, 8	Forward	-29 to 232 <sup>(3)</sup>	51.0	51.0	51.0	51.0	31.0	17.2	17.2	10.3	10.3	10.3	10.3	10.3	
	Reverse	-29 to 232 <sup>(3)</sup>	6.9	6.9	6.9	6.9	6.9	6.9	6.9	6.9	6.9	6.9	6.9	6.9	
9 <sup>(2)</sup> , 10	Forward or reverse	-29 to 149	19.7 <sup>(4)</sup>	31.5 <sup>(4)</sup>	28.8 <sup>(4)</sup>	20.2 <sup>(4)</sup>	24.3 <sup>(4)</sup>	13.4 <sup>(4)</sup>	9.0 <sup>(4)</sup>	5.3	10.0 <sup>(4)</sup>	6.4	3.8	7.9 <sup>(4)</sup>	
		204	18.2 <sup>(4)</sup>	29.9 <sup>(4)</sup>	27.4 <sup>(4)</sup>	20.2 <sup>(4)</sup>	24.3 <sup>(4)</sup>	12.8 <sup>(4)</sup>	8.5 <sup>(4)</sup>	4.9	9.5 <sup>(4)</sup>	6.1	3.5	7.5 <sup>(4)</sup>	
		260	17.3 <sup>(4)</sup>	28.9 <sup>(4)</sup>	26.5 <sup>(4)</sup>	19.6 <sup>(4)</sup>	24.3 <sup>(4)</sup>	12.3 <sup>(4)</sup>	8.2 <sup>(4)</sup>	4.7	9.2 <sup>(4)</sup>	5.8	3.3	7.3 <sup>(4)</sup>	
		316	16.8 <sup>(4)</sup>	28.3 <sup>(4)</sup>	26.0 <sup>(4)</sup>	19.2 <sup>(4)</sup>	24.0 <sup>(4)</sup>	12.1 <sup>(4)</sup>	8.1 <sup>(4)</sup>	4.6	9.0 <sup>(4)</sup>	5.7	3.2	7.2 <sup>(4)</sup>	
		371	15.9 <sup>(4)</sup>	27.3 <sup>(4)</sup>	25.1 <sup>(4)</sup>	18.6 <sup>(4)</sup>	23.3 <sup>(4)</sup>	11.7 <sup>(4)</sup>	7.7 <sup>(4)</sup>	4.3	8.8 <sup>(4)</sup>	5.4	3.0	7.0 <sup>(4)</sup>	
		427	15.0 <sup>(4)</sup>	26.3 <sup>(4)</sup>	24.2 <sup>(4)</sup>	17.9 <sup>(4)</sup>	22.6 <sup>(4)</sup>	11.2 <sup>(4)</sup>	7.4 <sup>(4)</sup>	4.1	8.4 <sup>(4)</sup>	5.2	2.8	6.7 <sup>(4)</sup>	
11	Forward or reverse	-29 to 93	19.7 <sup>(4)</sup>	21.9 <sup>(4)</sup>	18.5 <sup>(4)</sup>	17.0 <sup>(4)</sup>	14.6 <sup>(4)</sup>	9.1 <sup>(4)</sup>	9.0 <sup>(4)</sup>	5.2	7.4 <sup>(4)</sup>	5.7	3.7	6.7	
		149	17.1 <sup>(4)</sup>	21.9 <sup>(4)</sup>	18.5 <sup>(4)</sup>	17.0 <sup>(4)</sup>	14.6 <sup>(4)</sup>	9.1 <sup>(4)</sup>	8.1 <sup>(4)</sup>	4.6	7.4 <sup>(4)</sup>	5.7	3.2	6.7	
		204	15.0 <sup>(4)</sup>	21.9 <sup>(4)</sup>	18.5 <sup>(4)</sup>	17.0 <sup>(4)</sup>	14.6 <sup>(4)</sup>	9.1 <sup>(4)</sup>	7.4 <sup>(4)</sup>	4.1	7.4 <sup>(4)</sup>	5.2	2.8	6.7	
		260	14.6 <sup>(4)</sup>	21.9 <sup>(4)</sup>	18.5 <sup>(4)</sup>	17.0 <sup>(4)</sup>	14.6 <sup>(4)</sup>	9.1 <sup>(4)</sup>	7.2 <sup>(4)</sup>	3.9	7.4 <sup>(4)</sup>	5.1	2.8	6.6	
		316	13.9 <sup>(4)</sup>	21.9 <sup>(4)</sup>	18.5 <sup>(4)</sup>	17.0 <sup>(4)</sup>	14.6 <sup>(4)</sup>	9.1 <sup>(4)</sup>	7.0 <sup>(4)</sup>	3.8	7.4 <sup>(4)</sup>	4.9	2.6	6.4	
		371	13.3 <sup>(4)</sup>	21.9 <sup>(4)</sup>	18.5 <sup>(4)</sup>	16.8 <sup>(4)</sup>	14.6 <sup>(4)</sup>	9.1 <sup>(4)</sup>	6.8	3.7	7.4 <sup>(4)</sup>	4.8	2.6	6.3	
		427	12.6 <sup>(4)</sup>	21.9 <sup>(4)</sup>	18.5 <sup>(4)</sup>	16.3 <sup>(4)</sup>	14.6 <sup>(4)</sup>	9.1 <sup>(4)</sup>	6.6	3.4	7.4 <sup>(4)</sup>	4.6	2.3	6.1	
12	Forward or reverse	-46 to 149	19.7 <sup>(4)</sup>	21.9 <sup>(4)</sup>	18.5 <sup>(4)</sup>	17.0 <sup>(4)</sup>	14.6 <sup>(4)</sup>	9.1 <sup>(4)</sup>	9.0 <sup>(4)</sup>	5.3	7.4 <sup>(4)</sup>	5.7	3.8	6.7	
		204	18.2 <sup>(4)</sup>	21.9 <sup>(4)</sup>	18.5 <sup>(4)</sup>	17.0 <sup>(4)</sup>	14.6 <sup>(4)</sup>	9.1 <sup>(4)</sup>	8.5 <sup>(4)</sup>	4.9	7.4 <sup>(4)</sup>	5.7	3.5	6.7	
		260	17.3 <sup>(4)</sup>	21.9 <sup>(4)</sup>	18.5 <sup>(4)</sup>	17.0 <sup>(4)</sup>	14.6 <sup>(4)</sup>	9.1 <sup>(4)</sup>	8.2 <sup>(4)</sup>	4.7	7.4 <sup>(4)</sup>	5.7	3.3	6.7	
		316	16.8 <sup>(4)</sup>	21.9 <sup>(4)</sup>	18.5 <sup>(4)</sup>	17.0 <sup>(4)</sup>	14.6 <sup>(4)</sup>	9.1 <sup>(4)</sup>	8.1 <sup>(4)</sup>	4.6	7.4 <sup>(4)</sup>	5.7	3.2	6.7	
		371	15.9 <sup>(4)</sup>	21.9 <sup>(4)</sup>	18.5 <sup>(4)</sup>	17.0 <sup>(4)</sup>	14.6 <sup>(4)</sup>	9.1 <sup>(4)</sup>	7.7 <sup>(4)</sup>	4.3	7.4 <sup>(4)</sup>	5.4	3.0	6.7	
		427	15.0 <sup>(4)</sup>	21.9 <sup>(4)</sup>	18.5 <sup>(4)</sup>	17.0 <sup>(4)</sup>	14.6 <sup>(4)</sup>	9.1 <sup>(4)</sup>	7.4 <sup>(4)</sup>	4.1	7.4 <sup>(4)</sup>	5.2	2.8	6.7	
13	Forward or reverse	-29 to 149	12.3 <sup>(4)</sup>	11.0 <sup>(4)</sup>	9.2 <sup>(4)</sup>	8.5 <sup>(4)</sup>	7.3 <sup>(4)</sup>	4.6	4.6	3.5	3.7	2.8	3.0	3.3	
		204	12.3 <sup>(4)</sup>	11.0 <sup>(4)</sup>	9.2 <sup>(4)</sup>	8.5 <sup>(4)</sup>	7.3 <sup>(4)</sup>	4.6	4.6	3.5	3.7	2.8	2.8	3.3	
		260	12.3 <sup>(4)</sup>	11.0 <sup>(4)</sup>	9.2 <sup>(4)</sup>	8.5 <sup>(4)</sup>	7.3 <sup>(4)</sup>	4.6	4.6	3.5	3.7	2.8	2.8	3.3	
		316	12.3 <sup>(4)</sup>	11.0 <sup>(4)</sup>	9.2 <sup>(4)</sup>	8.5 <sup>(4)</sup>	7.3 <sup>(4)</sup>	4.6	4.6	3.5	3.7	2.8	2.6	3.3	
		371	12.3 <sup>(4)</sup>	11.0 <sup>(4)</sup>	9.2 <sup>(4)</sup>	8.5 <sup>(4)</sup>	7.3 <sup>(4)</sup>	4.6	4.6	3.5	3.7	2.8	2.6	3.3	
		427	12.3 <sup>(4)</sup>	11.0 <sup>(4)</sup>	9.2 <sup>(4)</sup>	8.5 <sup>(4)</sup>	7.3 <sup>(4)</sup>	4.6	4.6	3.4	3.7	2.8	2.3	3.3	
14	Forward	-29 to 427	12.3	11.0	9.2	8.5	7.3	4.6	4.6	3.5	3.7	2.8	3.0	3.3	
	Reverse	-29 to 427	6.9	6.9	6.9	6.9	6.9	4.6	4.6	3.5	3.7	2.8	3.0	3.3	
15	Forward or reverse	-29 to 49	52.4	60.4	50.3	57.9	51.4	33.4	33.8	---					
		66	52.4	58.5	50.3	57.9	51.4	33.4	33.8	---					
		93	43.0	43.0	43.0	43.0	43.0	33.4	33.8	---					
		121	38.6	38.6	38.6	38.6	38.6	33.4	33.8	---					
		149	28.7	28.7	28.7	28.7	28.7	28.7	28.7	---					
		191	13.8	13.8	13.8	13.8	13.8	13.8	13.8	---					
		204	10.3	10.3	10.3	10.3	10.3	10.3	10.3	---					
		232	3.4	3.4	3.4	3.4	3.4	---							

1. Based on valve body assembly material strengths only—actuator torque not considered.
2. This trim not available in the NPS 2, 3, and 4 valves.
3. For hot water or steam service, limit maximum temperature to 207°C.
4. Reverse pressure drop is limited to 6.9 bar.

# Product Bulletin

51.6:edisc (EMA)

February 2007

# 8510/8510B Valve

Table 7. Maximum Allowable Shutoff Pressure Drops<sup>(1)</sup> in Psi for Steel Valve Body Material

TABLE 4 OR 5 TRIM NUMBER	FLOW DIRECTION	TEMP. °F	MAX ALLOWABLE SHUTOFF ΔP (PER VALVE BODY SIZE, NPS)												
			8510B						8510						
			2	3	4	6	8	10	12	14	16	18	20	24	
1 <sup>(2)</sup> , 2, 3, 4, NT3	Forward or reverse	-20 to 120	816	935	780	840	792	547	600	285	285	285	285	285	
		150	816	848	780	840	792	547	600	275	275	275	275	275	
		200	704	704	704	704	704	547	600	260	260	260	260	260	
		250	560	560	560	560	560	547	600	245	245	245	245	245	
		300	416	416	416	416	416	416	416	230	230	230	230	230	
		375	200	200	200	200	200	200	200	200	200	200	200	200	
		400	150	150	150	150	150	150	150	150	150	150	150	150	
450 <sup>(3)</sup>	50	50	50	50	50	50	50	50	50	50	50	50	50		
5 <sup>(2)</sup> , 6, 7, 8	Forward	-20 to 450 <sup>(3)</sup>	740	740	740	740	450	250	250	150	150	150	150	150	
	Reverse	-20 to 450 <sup>(3)</sup>	100	100	100	100	100	100	100	100	100	100	100	100	
9 <sup>(2)</sup> , 10	Forward or reverse	-20 to 300	285 <sup>(4)</sup>	457 <sup>(4)</sup>	417 <sup>(4)</sup>	307 <sup>(4)</sup>	353 <sup>(4)</sup>	194 <sup>(4)</sup>	131 <sup>(4)</sup>	77	145 <sup>(4)</sup>	93	55	115 <sup>(4)</sup>	
		400	264 <sup>(4)</sup>	434 <sup>(4)</sup>	397 <sup>(4)</sup>	293 <sup>(4)</sup>	353 <sup>(4)</sup>	185 <sup>(4)</sup>	124 <sup>(4)</sup>	71	138 <sup>(4)</sup>	88	51	109 <sup>(4)</sup>	
		500	251 <sup>(4)</sup>	419 <sup>(4)</sup>	384 <sup>(4)</sup>	284 <sup>(4)</sup>	353 <sup>(4)</sup>	179 <sup>(4)</sup>	119 <sup>(4)</sup>	68	133 <sup>(4)</sup>	84	48	106 <sup>(4)</sup>	
		600	244 <sup>(4)</sup>	411 <sup>(4)</sup>	377 <sup>(4)</sup>	279 <sup>(4)</sup>	348 <sup>(4)</sup>	175 <sup>(4)</sup>	117 <sup>(4)</sup>	66	131 <sup>(4)</sup>	83	47	104 <sup>(4)</sup>	
		700	231 <sup>(4)</sup>	396 <sup>(4)</sup>	364 <sup>(4)</sup>	270 <sup>(4)</sup>	338 <sup>(4)</sup>	169 <sup>(4)</sup>	112 <sup>(4)</sup>	62	127 <sup>(4)</sup>	79	44	101 <sup>(4)</sup>	
		800	218 <sup>(4)</sup>	381 <sup>(4)</sup>	351 <sup>(4)</sup>	260 <sup>(4)</sup>	328 <sup>(4)</sup>	163 <sup>(4)</sup>	107 <sup>(4)</sup>	59	122 <sup>(4)</sup>	78	41	97 <sup>(4)</sup>	
11	Forward or reverse	-20 to 200	285 <sup>(4)</sup>	318 <sup>(4)</sup>	268 <sup>(4)</sup>	246 <sup>(4)</sup>	212 <sup>(4)</sup>	132 <sup>(4)</sup>	130 <sup>(4)</sup>	76	107 <sup>(4)</sup>	82	54	97	
		300	248 <sup>(4)</sup>	318 <sup>(4)</sup>	268 <sup>(4)</sup>	246 <sup>(4)</sup>	212 <sup>(4)</sup>	132 <sup>(4)</sup>	118 <sup>(4)</sup>	67	107 <sup>(4)</sup>	82	47	97	
		400	218 <sup>(4)</sup>	318 <sup>(4)</sup>	268 <sup>(4)</sup>	246 <sup>(4)</sup>	212 <sup>(4)</sup>	132 <sup>(4)</sup>	107 <sup>(4)</sup>	59	107 <sup>(4)</sup>	75	41	97	
		500	212 <sup>(4)</sup>	318 <sup>(4)</sup>	268 <sup>(4)</sup>	246 <sup>(4)</sup>	212 <sup>(4)</sup>	132 <sup>(4)</sup>	105 <sup>(4)</sup>	57	107 <sup>(4)</sup>	74	40	96	
		600	201 <sup>(4)</sup>	318 <sup>(4)</sup>	268 <sup>(4)</sup>	246 <sup>(4)</sup>	212 <sup>(4)</sup>	132 <sup>(4)</sup>	102 <sup>(4)</sup>	55	107 <sup>(4)</sup>	71	38	93	
		700	193 <sup>(4)</sup>	318 <sup>(4)</sup>	268 <sup>(4)</sup>	246 <sup>(4)</sup>	212 <sup>(4)</sup>	132 <sup>(4)</sup>	99	53	107 <sup>(4)</sup>	69	37	91	
		800	183 <sup>(4)</sup>	318 <sup>(4)</sup>	268 <sup>(4)</sup>	236 <sup>(4)</sup>	212 <sup>(4)</sup>	132 <sup>(4)</sup>	95	50	107 <sup>(4)</sup>	66	34	88	
12	Forward or reverse	-20 to 300	285 <sup>(4)</sup>	318 <sup>(4)</sup>	268 <sup>(4)</sup>	246 <sup>(4)</sup>	212 <sup>(4)</sup>	132 <sup>(4)</sup>	131 <sup>(4)</sup>	77	107 <sup>(4)</sup>	82	55	97	
		400	264 <sup>(4)</sup>	318 <sup>(4)</sup>	268 <sup>(4)</sup>	246 <sup>(4)</sup>	212 <sup>(4)</sup>	132 <sup>(4)</sup>	124 <sup>(4)</sup>	71	107 <sup>(4)</sup>	82	51	97	
		500	251 <sup>(4)</sup>	318 <sup>(4)</sup>	268 <sup>(4)</sup>	246 <sup>(4)</sup>	212 <sup>(4)</sup>	132 <sup>(4)</sup>	119 <sup>(4)</sup>	68	107 <sup>(4)</sup>	82	48	97	
		600	244 <sup>(4)</sup>	318 <sup>(4)</sup>	268 <sup>(4)</sup>	246 <sup>(4)</sup>	212 <sup>(4)</sup>	132 <sup>(4)</sup>	117 <sup>(4)</sup>	66	107 <sup>(4)</sup>	82	47	97	
		700	231 <sup>(4)</sup>	318 <sup>(4)</sup>	268 <sup>(4)</sup>	246 <sup>(4)</sup>	212 <sup>(4)</sup>	132 <sup>(4)</sup>	112 <sup>(4)</sup>	62	107 <sup>(4)</sup>	79	44	97	
		800	218 <sup>(4)</sup>	318 <sup>(4)</sup>	268 <sup>(4)</sup>	246 <sup>(4)</sup>	212 <sup>(4)</sup>	132 <sup>(4)</sup>	107 <sup>(4)</sup>	59	107 <sup>(4)</sup>	75	41	97	
13	Forward or reverse	-20 to 300	178 <sup>(4)</sup>	159 <sup>(4)</sup>	134 <sup>(4)</sup>	123 <sup>(4)</sup>	106 <sup>(4)</sup>	66	67	51	53	41	44	48	
		400	178 <sup>(4)</sup>	159 <sup>(4)</sup>	134 <sup>(4)</sup>	123 <sup>(4)</sup>	106 <sup>(4)</sup>	66	67	51	53	41	41	48	
		500	178 <sup>(4)</sup>	159 <sup>(4)</sup>	134 <sup>(4)</sup>	123 <sup>(4)</sup>	106 <sup>(4)</sup>	66	67	51	53	41	40	48	
		600	178 <sup>(4)</sup>	159 <sup>(4)</sup>	134 <sup>(4)</sup>	123 <sup>(4)</sup>	106 <sup>(4)</sup>	66	67	51	53	41	38	48	
		700	178 <sup>(4)</sup>	159 <sup>(4)</sup>	134 <sup>(4)</sup>	123 <sup>(4)</sup>	106 <sup>(4)</sup>	66	67	51	53	41	37	48	
		800	178 <sup>(4)</sup>	159 <sup>(4)</sup>	134 <sup>(4)</sup>	123 <sup>(4)</sup>	106 <sup>(4)</sup>	66	67	50	53	41	34	48	
14	Forward	-20 to 800	178	159	134	123	106	66	67	51	53	41	44	48	
	Reverse	-20 to 800	100	100	100	100	100	66	67	51	53	41	44	48	
15	Forward or reverse	-20 to 120	760	876	730	840	746	484	490	---					
		150	760	848	730	840	746	484	490	---					
		200	704	704	704	704	704	484	490	---					
		250	560	560	560	560	560	484	490	---					
		300	416	416	416	416	416	416	416	---					
		375	200	200	200	200	200	200	200	---					
		400	150	150	150	150	150	150	150	---					
		450	50	50	50	50	50	50	50	---					

1. Based on valve body assembly material strengths only—actuator torque not considered.

2. This trim not available in the NPS 2 and 3 valves.

3. For hot water or steam service, limit maximum temperature to 405°F.

4. Reverse pressure drop is limited to 100 psi.

# 8510/8510B Valve

Product Bulletin  
51.6:edisc (EMA)  
February 2007

Table 8. Maximum Allowable Shutoff Pressure Drops<sup>(1)</sup> in Bar for Stainless Steel Valve Body Material

TABLE 4 OR 5 TRIM NUMBER	FLOW DIRECTION	TEMP. °C	MAX ALLOWABLE SHUTOFF ΔP (PER VALVE BODY SIZE, NPS)											
			8510B						8510					
			2	3	4	6	8	10	12	14	16	18	20	24
3, 4, NT3	Forward or reverse	-46 to 49	56.2	64.5	53.8	57.9	54.6	37.7	41.4	19.7	19.7	19.7	19.7	19.7
		66	56.2	58.5	53.8	57.9	54.6	37.7	41.4	19.0	19.0	19.0	19.0	19.0
		93	48.5	48.5	48.5	48.5	48.5	37.7	41.4	17.9	17.9	17.9	17.9	17.9
		121	38.6	38.6	38.6	38.6	38.6	37.7	38.6	16.9	16.9	16.9	16.9	16.9
		149	28.7	28.7	28.7	28.7	28.7	28.7	28.7	15.5	15.5	15.5	15.5	15.5
		191	13.8	13.8	13.8	13.8	13.8	13.8	13.8	13.8	13.8	13.8	13.8	13.8
		204	10.3	10.3	10.3	10.3	10.3	10.3	10.3	10.3	10.3	10.3	10.3	10.3
		232 <sup>(2)</sup>	3.4	3.4	3.4	3.4	3.4	3.4	3.4	3.4	3.4	3.4	3.4	3.4
7	Forward	-46 to 232 <sup>(2)</sup>	51.0	51.0	51.0	51.0	31.0	17.2	17.2	10.3	10.3	10.3	10.3	10.3
	Reverse	-46 to 232 <sup>(2)</sup>	6.9	6.9	6.9	6.9	6.9	6.9	6.9	6.9	6.9	6.9	6.9	6.9
8	Forward	-46 to 232 <sup>(2)</sup>	51.0	51.0	51.0	51.0	31.0	17.2	17.2	10.3	10.3	10.3	10.3	10.3
	Reverse	-46 to 232 <sup>(2)</sup>	6.9	6.9	6.9	6.9	6.9	6.9	6.9	6.9	6.9	6.9	6.9	6.9
11x7.4 <sup>(3)</sup>	Forward or reverse	-46 to 93	19.7 <sup>(3)</sup>	21.9 <sup>(3)</sup>	18.5 <sup>(3)</sup>	17.0 <sup>(3)</sup>	14.6 <sup>(3)</sup>	9.1 <sup>(3)</sup>	9.0 <sup>(3)</sup>	5.2	7.4 <sup>(3)</sup>	5.7	3.7	6.7
		149	17.1 <sup>(3)</sup>	21.9 <sup>(3)</sup>	18.5 <sup>(3)</sup>	17.0 <sup>(3)</sup>	14.6 <sup>(3)</sup>	9.1 <sup>(3)</sup>	8.1 <sup>(3)</sup>	4.6	7.4 <sup>(3)</sup>	5.7	3.2	6.7
		204	15.0 <sup>(3)</sup>	21.9 <sup>(3)</sup>	18.5 <sup>(3)</sup>	17.0 <sup>(3)</sup>	14.6 <sup>(3)</sup>	9.1 <sup>(3)</sup>	7.4 <sup>(3)</sup>	4.1	7.4 <sup>(3)</sup>	5.2	2.8	6.7
		260	14.6 <sup>(3)</sup>	21.9 <sup>(3)</sup>	18.5 <sup>(3)</sup>	17.0 <sup>(3)</sup>	14.6 <sup>(3)</sup>	9.1 <sup>(3)</sup>	7.2 <sup>(3)</sup>	3.9	7.4 <sup>(3)</sup>	5.1	2.8	6.6
		316	13.9 <sup>(3)</sup>	21.9 <sup>(3)</sup>	18.5 <sup>(3)</sup>	17.0 <sup>(3)</sup>	14.6 <sup>(3)</sup>	9.1 <sup>(3)</sup>	7.0 <sup>(3)</sup>	3.8	7.4 <sup>(3)</sup>	4.9	2.6	6.4
		371	13.3 <sup>(3)</sup>	21.9 <sup>(3)</sup>	18.5 <sup>(3)</sup>	16.8 <sup>(3)</sup>	14.6 <sup>(3)</sup>	9.1 <sup>(3)</sup>	6.8	3.7	7.4 <sup>(3)</sup>	4.8	2.6	6.3
		427	12.6 <sup>(3)</sup>	21.9 <sup>(3)</sup>	18.5 <sup>(3)</sup>	16.3 <sup>(3)</sup>	14.6 <sup>(3)</sup>	9.1 <sup>(3)</sup>	6.6	3.4	7.4 <sup>(3)</sup>	4.6	2.3	6.1
		482	11.9 <sup>(3)</sup>	21.9 <sup>(3)</sup>	18.5 <sup>(3)</sup>	15.8 <sup>(3)</sup>	14.6 <sup>(3)</sup>	9.1 <sup>(3)</sup>	6.3	3.2	7.3 <sup>(3)</sup>	4.3	2.2	5.9
438	11.1 <sup>(3)</sup>	21.9 <sup>(3)</sup>	18.5 <sup>(3)</sup>	15.2 <sup>(3)</sup>	14.6 <sup>(3)</sup>	9.1 <sup>(3)</sup>	6.1	3.0	7.0 <sup>(3)</sup>	4.1	2.1	5.7		
12	Forward or reverse	-46 to 149	19.7 <sup>(3)</sup>	21.9 <sup>(3)</sup>	18.5 <sup>(3)</sup>	17.0 <sup>(3)</sup>	14.6 <sup>(3)</sup>	9.1 <sup>(3)</sup>	9.0 <sup>(3)</sup>	5.3	7.4 <sup>(3)</sup>	5.7	3.8	6.7
		204	18.2 <sup>(3)</sup>	21.9 <sup>(3)</sup>	18.5 <sup>(3)</sup>	17.0 <sup>(3)</sup>	14.6 <sup>(3)</sup>	9.1 <sup>(3)</sup>	8.5 <sup>(3)</sup>	4.9	7.4 <sup>(3)</sup>	5.7	3.5	6.7
		260	17.3 <sup>(3)</sup>	21.9 <sup>(3)</sup>	18.5 <sup>(3)</sup>	17.0 <sup>(3)</sup>	14.6 <sup>(3)</sup>	9.1 <sup>(3)</sup>	8.2 <sup>(3)</sup>	4.7	7.4 <sup>(3)</sup>	5.7	3.3	6.7
		316	16.8 <sup>(3)</sup>	21.9 <sup>(3)</sup>	18.5 <sup>(3)</sup>	17.0 <sup>(3)</sup>	14.6 <sup>(3)</sup>	9.1 <sup>(3)</sup>	8.1 <sup>(3)</sup>	4.6	7.4 <sup>(3)</sup>	5.7	3.2	6.7
		371	15.9 <sup>(3)</sup>	21.9 <sup>(3)</sup>	18.5 <sup>(3)</sup>	17.0 <sup>(3)</sup>	14.6 <sup>(3)</sup>	9.1 <sup>(3)</sup>	7.7 <sup>(3)</sup>	4.3	7.4 <sup>(3)</sup>	5.4	3.0	6.7
		427	15.0 <sup>(3)</sup>	21.9 <sup>(3)</sup>	18.5 <sup>(3)</sup>	17.0 <sup>(3)</sup>	14.6 <sup>(3)</sup>	9.1 <sup>(3)</sup>	7.4 <sup>(3)</sup>	4.1	7.4 <sup>(3)</sup>	5.2	2.8	6.7
13	Forward or reverse	-46 to 149	12.3 <sup>(3)</sup>	11.0 <sup>(3)</sup>	9.2 <sup>(3)</sup>	8.5 <sup>(3)</sup>	7.3 <sup>(3)</sup>	4.6	4.6	3.5	3.7	2.8	3.0	3.3
		204	12.3 <sup>(3)</sup>	11.0 <sup>(3)</sup>	9.2 <sup>(3)</sup>	8.5 <sup>(3)</sup>	7.3 <sup>(3)</sup>	4.6	4.6	3.5	3.7	2.8	2.8	3.3
		260	12.3 <sup>(3)</sup>	11.0 <sup>(3)</sup>	9.2 <sup>(3)</sup>	8.5 <sup>(3)</sup>	7.3 <sup>(3)</sup>	4.6	4.6	3.5	3.7	2.8	2.8	3.3
		316	12.3 <sup>(3)</sup>	11.0 <sup>(3)</sup>	9.2 <sup>(3)</sup>	8.5 <sup>(3)</sup>	7.3 <sup>(3)</sup>	4.6	4.6	3.5	3.7	2.8	2.6	3.3
		371	12.3 <sup>(3)</sup>	11.0 <sup>(3)</sup>	9.2 <sup>(3)</sup>	8.5 <sup>(3)</sup>	7.3 <sup>(3)</sup>	4.6	4.6	3.5	3.7	2.8	2.6	3.3
		427	12.3 <sup>(3)</sup>	11.0 <sup>(3)</sup>	9.2 <sup>(3)</sup>	8.5 <sup>(3)</sup>	7.3 <sup>(3)</sup>	4.6	4.6	3.4	3.7	2.8	2.3	3.3
		482	11.9 <sup>(3)</sup>	11.0 <sup>(3)</sup>	9.2 <sup>(3)</sup>	8.5 <sup>(3)</sup>	7.3 <sup>(3)</sup>	4.6	4.6	3.2	3.7	2.8	2.2	3.3
		538	11.1 <sup>(3)</sup>	11.0 <sup>(3)</sup>	9.2 <sup>(3)</sup>	8.5 <sup>(3)</sup>	7.3 <sup>(3)</sup>	4.6	4.6	3.0	3.7	2.8	2.1	3.3
14	Forward	-46 to 371	12.3	11.0	9.2	8.5	7.3	4.6	4.6	3.5	3.7	2.8	3.0	3.3
	Reverse	-46 to 371	6.9	6.9	6.9	6.9	6.9	4.6	4.6	3.5	3.7	2.8	3.0	3.3

1. Based on valve body assembly material strengths only—actuator torque not considered.  
2. For hot water or steam service, limit maximum temperature to 207°C.  
3. Reverse pressure drop is limited to 6.9 bar.

# Product Bulletin

51.6:edisc (EMA)

February 2007

# 8510/8510B Valve

Table 9. Maximum Allowable Shutoff Pressure Drops<sup>(1)</sup> in Psi for Stainless Steel Valve Body Material

TABLE 4 OR 5 TRIM NUMBER	FLOW DIRECTION	TEMP. °F	MAX ALLOWABLE SHUTOFF ΔP (PER VALVE BODY SIZE, NPS)											
			8510B						8510					
			2	3	4	6	8	10	12	14	16	18	20	24
3, 4, NT3	Forward or reverse	-50 to 120	816	935	780	840	792	547	600	275	275	275	275	275
		150	816	848	780	840	792	547	600	257	257	257	257	257
		200	704	704	704	704	704	547	600	240	240	240	240	240
		250	560	560	560	560	560	547	560	227	227	227	227	227
		300	416	416	416	416	416	416	416	215	215	215	215	215
		375	200	200	200	200	200	200	200	200	200	200	200	200
		400	150	150	150	150	150	150	150	150	150	150	150	150
		450 <sup>(2)</sup>	50	50	50	50	50	50	50	50	50	50	50	
7	Forward	-50 to 450 <sup>(2)</sup>	740	740	740	740	450	250	250	150	150	150	150	150
	Reverse	-50 to 450 <sup>(2)</sup>	100	100	100	100	100	100	100	100	100	100	100	100
8	Forward	-50 to 450 <sup>(2)</sup>	740	740	740	740	450	250	250	150	150	150	150	150
	Reverse	-50 to 450 <sup>(2)</sup>	100	100	100	100	100	100	100	100	100	100	100	100
11	Forward or reverse	-50 to 200	285 <sup>(3)</sup>	318 <sup>(3)</sup>	268 <sup>(3)</sup>	246 <sup>(3)</sup>	212 <sup>(3)</sup>	132 <sup>(3)</sup>	130 <sup>(3)</sup>	76	107 <sup>(3)</sup>	82	54	97
		300	248 <sup>(3)</sup>	318 <sup>(3)</sup>	268 <sup>(3)</sup>	246 <sup>(3)</sup>	212 <sup>(3)</sup>	132 <sup>(3)</sup>	118 <sup>(3)</sup>	67	107 <sup>(3)</sup>	82	54	97
		400	218 <sup>(3)</sup>	318 <sup>(3)</sup>	268 <sup>(3)</sup>	246 <sup>(3)</sup>	212 <sup>(3)</sup>	132 <sup>(3)</sup>	107 <sup>(3)</sup>	59	107 <sup>(3)</sup>	75	41	97
		500	212 <sup>(3)</sup>	318 <sup>(3)</sup>	268 <sup>(3)</sup>	246 <sup>(3)</sup>	212 <sup>(3)</sup>	132 <sup>(3)</sup>	105 <sup>(3)</sup>	57	107 <sup>(3)</sup>	74	40	96
		600	201 <sup>(3)</sup>	318 <sup>(3)</sup>	268 <sup>(3)</sup>	246 <sup>(3)</sup>	212 <sup>(3)</sup>	132 <sup>(3)</sup>	102 <sup>(3)</sup>	55	107 <sup>(3)</sup>	71	38	93
		700	193 <sup>(3)</sup>	318 <sup>(3)</sup>	268 <sup>(3)</sup>	243 <sup>(3)</sup>	212 <sup>(3)</sup>	132 <sup>(3)</sup>	99	53	107 <sup>(3)</sup>	69	37	91
		800	183 <sup>(3)</sup>	318 <sup>(3)</sup>	268 <sup>(3)</sup>	236 <sup>(3)</sup>	212 <sup>(3)</sup>	132 <sup>(3)</sup>	95	50	107 <sup>(3)</sup>	66	34	88
		900	172 <sup>(3)</sup>	318 <sup>(3)</sup>	268 <sup>(3)</sup>	229 <sup>(3)</sup>	212 <sup>(3)</sup>	132 <sup>(3)</sup>	91	47	106 <sup>(3)</sup>	63	32	85
		1000	161 <sup>(3)</sup>	318 <sup>(3)</sup>	268 <sup>(3)</sup>	221 <sup>(3)</sup>	212 <sup>(3)</sup>	132 <sup>(3)</sup>	88	44	102 <sup>(3)</sup>	60	30	82
12	Forward or reverse	-50 to 300	285 <sup>(3)</sup>	318 <sup>(3)</sup>	268 <sup>(3)</sup>	246 <sup>(3)</sup>	212 <sup>(3)</sup>	132 <sup>(3)</sup>	131 <sup>(3)</sup>	77	107 <sup>(3)</sup>	82	55	97
		400	264 <sup>(3)</sup>	318 <sup>(3)</sup>	268 <sup>(3)</sup>	246 <sup>(3)</sup>	212 <sup>(3)</sup>	132 <sup>(3)</sup>	124 <sup>(3)</sup>	71	107 <sup>(3)</sup>	82	51	97
		500	251 <sup>(3)</sup>	318 <sup>(3)</sup>	268 <sup>(3)</sup>	246 <sup>(3)</sup>	212 <sup>(3)</sup>	132 <sup>(3)</sup>	119 <sup>(3)</sup>	68	107 <sup>(3)</sup>	82	48	97
		600	244 <sup>(3)</sup>	318 <sup>(3)</sup>	268 <sup>(3)</sup>	246 <sup>(3)</sup>	212 <sup>(3)</sup>	132 <sup>(3)</sup>	117 <sup>(3)</sup>	66	107 <sup>(3)</sup>	82	47	97
		700	231 <sup>(3)</sup>	318 <sup>(3)</sup>	268 <sup>(3)</sup>	246 <sup>(3)</sup>	212 <sup>(3)</sup>	132 <sup>(3)</sup>	112 <sup>(3)</sup>	62	107 <sup>(3)</sup>	79	44	97
		800	218 <sup>(3)</sup>	318 <sup>(3)</sup>	268 <sup>(3)</sup>	246 <sup>(3)</sup>	212 <sup>(3)</sup>	132 <sup>(3)</sup>	107 <sup>(3)</sup>	59	107 <sup>(3)</sup>	75	41	97
13	Forward or reverse	-50 to 300	178 <sup>(3)</sup>	159 <sup>(3)</sup>	134 <sup>(3)</sup>	123 <sup>(3)</sup>	106 <sup>(3)</sup>	66	67	51	53	41	44	48
		400	178 <sup>(3)</sup>	159 <sup>(3)</sup>	134 <sup>(3)</sup>	123 <sup>(3)</sup>	106 <sup>(3)</sup>	66	67	51	53	41	41	48
		500	178 <sup>(3)</sup>	159 <sup>(3)</sup>	134 <sup>(3)</sup>	123 <sup>(3)</sup>	106 <sup>(3)</sup>	66	67	51	53	41	40	48
		600	178 <sup>(3)</sup>	159 <sup>(3)</sup>	134 <sup>(3)</sup>	123 <sup>(3)</sup>	106 <sup>(3)</sup>	66	67	51	53	41	38	48
		700	178 <sup>(3)</sup>	159 <sup>(3)</sup>	134 <sup>(3)</sup>	123 <sup>(3)</sup>	106 <sup>(3)</sup>	66	67	51	53	41	37	48
		800	178 <sup>(3)</sup>	159 <sup>(3)</sup>	134 <sup>(3)</sup>	123 <sup>(3)</sup>	106 <sup>(3)</sup>	66	67	50	53	41	34	48
		900	172 <sup>(3)</sup>	159 <sup>(3)</sup>	134 <sup>(3)</sup>	123 <sup>(3)</sup>	106 <sup>(3)</sup>	66	67	47	53	41	32	48
		1000	161 <sup>(3)</sup>	159 <sup>(3)</sup>	134 <sup>(3)</sup>	123 <sup>(3)</sup>	106 <sup>(3)</sup>	66	67	44	53	41	30	48
14	Forward	-50 to 800	178	159	134	123	106	66	67	51	53	41	44	48
	Reverse	-50 to 800	100	100	100	100	100	66	67	51	53	41	44	48

1. Based on valve body assembly material strengths only—actuator torque not considered.  
 2. For hot water or steam service, limit maximum temperature to 405°F.  
 3. Reverse pressure drop is limited to 100 psi.

# 8510/8510B Valve

Table 10. Maximum Allowable Forward and Reverse Shutoff Pressure Drops<sup>(1)</sup> for Alloy Valve Body Materials

ALLOY VALVE BODY MATERIAL	TABLE 5 TRIM NUMBER	TEMPERATURE		MAX ALLOWABLE SHUTOFF ΔP (PER VALVE BODY SIZE, NPS)													
				8510B													
		°C	°F	2		3		4		6		8		10		12	
		Bar	Psi	Bar	Psi	Bar	Psi	Bar	Psi	Bar	Psi	Bar	Psi	Bar	Psi	Bar	Psi
M35-1	15	-46 to 49	-50 to 120	52.4	760	60.4	876	50.3	730	57.9	840	51.4	746	33.4	484	33.8	490
		93	200	40.3	584	45.8	664	38.9	564	44.1	639	39.6	575	27.2	395	27.5	399
		149	300	25.2	365	27.5	399	24.5	356	26.8	388	24.8	360	19.6	284	19.7	285
		191	375	13.8	200	13.8	200	13.8	200	13.8	200	13.8	200	13.8	200	13.8	200
		204	400	10.3	150	10.3	150	10.3	150	10.3	150	10.3	150	10.3	150	10.3	150
		232	450	3.4	50	3.4	50	3.4	50	3.4	50	3.4	50	3.4	50	3.4	50
Alloy 20 CN7M	17	-46 to 49	-50 to 120	18.6	270	33.2	482	34.3	497	24.0	348	32.1	465	16.8	244	12.7	184
		66	150	18.1	262	31.0	449	31.9	462	22.8	331	29.9	434	16.5	239	---	---
		93	200	17.1	248	27.1	393	27.9	404	20.8	302	26.3	382	15.9	230	---	---
		149	300	15.2	221	19.5	283	19.8	287	16.8	244	19.2	278	14.7	213	---	---

1. Based on valve body assembly material strengths only—actuator torque not considered.

Table 11. Material Temperature Capabilities

VALVE BODY MATERIAL	TABLE 4 OR 5 TRIM NUMBER	PACKING	MATERIAL TEMPERATURE CAPABILITY <sup>(1)</sup>	
			°C	°F
Steel	1, 2, 3, 4, 5, 6, 7, 8	All	-29 to 232 <sup>(1)</sup>	-20 to 450 <sup>(1)</sup>
	9, 10, 11, 12, 13, 14	PTFE V-ring or PTFE composition	-29 to 232	-20 to 450
		Graphite ribbon	-29 to 427	-20 to 800
	15	All	-29 to 232	-20 to 450
NT3	PTFE V-ring	-29 to 232 <sup>(1)</sup>	-20 to 450 <sup>(1)</sup>	
316 stainless steel	3, 4, 8	PTFE V-ring	-40 to 232 <sup>(1)</sup>	-40 to 450 <sup>(1)</sup>
		PTFE composition or graphite ribbon	-46 to 232 <sup>(1)</sup>	-50 to 450 <sup>(1)</sup>
	7	PTFE V-ring	-40 to 232 <sup>(1)</sup>	-40 to 450 <sup>(1)</sup>
		PTFE composition	-46 to 232 <sup>(1)</sup>	-50 to 450 <sup>(1)</sup>
		Graphite ribbon	-46 to 232 <sup>(1)</sup>	-50 to 450 <sup>(1)</sup>
11, 13	PTFE V-ring	-40 to 232	-40 to 450 <sup>(1)</sup>	
	PTFE composition Graphite ribbon	-46 to 260 -46 to 538	-50 to 500 -50 to 1000	
12, 14	PTFE V-ring	-40 to 232	-40 to 450	
	PTFE composition Graphite ribbon	-46 to 260 -46 to 427	-50 to 500 -50 to 800	
NT3	PTFE V-ring	-40 to 232 <sup>(1)</sup>	-40 to 450 <sup>(1)</sup>	
M35-1	15	PTFE V-ring	-40 to 232	-40 to 450
		PTFE composition or graphite ribbon	-46 to 232	-50 to 450
Alloy 20	17	PTFE V-ring	-40 to 149	-40 to 300
		PTFE composition or graphite ribbon	-46 to 149	-50 to 300

1. For hot water or steam service, limit maximum temperature to 207°C (405°F)

### **Material Selection Guidelines**

Pick the valve body, trim, and other construction materials from tables 3, 4, and 5, according to the recommendations and limitations in tables 6, 7, 8, 9, 10, and 11. Also, make sure that the pressure/temperature limits in the specifications table and tables 1, 2, 6, 7, 8, 9, 10, and 11 are not exceeded.

### **Installation**

As indicated in this bulletin, M35-1 valve bodies are not ASME B16.34 or ASME code-approved materials. Valve bodies constructed of M35-1 will mate with ASME flanges, but are not included in ASME pressure-temperature ratings and must not be installed in systems requiring conformance to ASME standards.

An 8510 and 8510B valve may be installed in any position.

Dimensions are shown in figure 9.

### **Ordering Information**

When ordering, specify:

#### **Application**

1. Type of application
  - a. Throttling or on/off
  - b. Reducing or relief
2. Controlled fluid

3. Specific gravity of controlled fluid
4. Fluid temperature
5. Range of flowing inlet pressures
6. Pressure drops
  - a. Range of flowing pressure drops
  - b. Maximum at shutoff
7. Flow rates
  - a. Minimum controlled flow
  - b. Normal flow
  - c. Maximum flow
8. Maximum permissible noise level, if critical
9. Line size and schedule

### **Valve Information**

Refer to the Specifications table. Review the information under each specification and in the referenced tables. Indicate the choice wherever there is a selection to be made.

### **Actuator and Accessory Information**

Specify the desired actuator type and size from the separate actuator bulletin. Also refer to the separate actuator and accessory bulletins for additional ordering information.

# 8510/8510B Valve

Table 12. Dimensions for Fisher 8510 and 8510B

VALVE SIZE, NPS	A	B	D	F	G	K	R	S (SHAFT DIA)	T	U	W	APPROXIMATE WEIGHT <sup>(1)</sup>
	mm											
2	45	59	187	141	138	102	103	12.7	117	---	1/2-13	4.3
3	48	78	187	168	155	119	127	15.9	117	---	1/2-13	5.9
4	56	102	214	197	198	162	159	19.1	152	32	1/2-13	9.1
6	57	141	214	251	238	202	217	25.4	152	32	1/2-13	19
8	64	191	208	317	289	244	272	31.8	235	46	5/8-11	31
10	71	241	208	378	289	257	325	31.8	235	46	5/8-11	46
12	83	286	208	438	348	297	384	38.1	235	46	5/8-11	72
14	92	329	208	416	362	311	416	38.1	235	46	5/8-11	88
16	102	376	356	473	409	359	473	44.5	273	51	3/4-10	102
18	114	427	356	536	397	346	536	44.5	273	51	3/4-10	136
20	127	470	356	589	464	406	589	50.8	273	51	3/4-10	204
24	154	564	356	699	522	465	699	63.5	337	76	7/8-9	277
	Inches											Pounds
2	1.78	2.31	7.38	5.56	5.44	4.00	4.06	0.5	4.62	---	1/2-13	9.5
3	1.88	3.06	7.38	6.62	6.12	4.69	5.00	0.625	4.62	---	1/2-13	13
4	2.19	4.00	8.44	7.75	7.81	6.38	6.25	0.75	6.00	1.25	1/2-13	20
6	2.25	5.56	8.44	9.88	9.38	7.94	8.53	1	6.00	1.25	1/2-13	41
8	2.5	7.50	8.19	12.50	11.38	9.62	10.69	1.25	9.25	1.81	5/8-11	69
10	2.81	9.50	8.19	14.88	11.38	10.12	12.81	1.25	9.25	1.81	5/8-11	102
12	3.25	11.25	8.19	17.25	13.69	11.69	15.12	1.5	9.25	1.81	5/8-11	158
14	3.62	12.94	8.19	16.38	14.25	12.25	16.38	1.5	9.25	1.81	5/8-11	194
16	4.00	14.81	14.00	18.62	16.12	14.12	18.62	1.75	10.75	2.00	3/4-10	225
18	4.50	16.81	14.00	21.12	15.62	13.62	21.12	1.75	10.75	2.00	3/4-10	300
20	5.00	18.50	14.00	23.19	18.25	16.00	23.19	2	10.75	2.00	3/4-10	450
24	6.06	22.19	14.00	27.50	20.56	18.31	27.50	2.5	13.25	3.00	7/8-9	610

1. Valve assembly only.

Table 13. Dimensions for Fisher 8510 and 8510B

DIN VALVE BODY SIZE	A FACE-TO-FACE	RAISED FACE			
		mm			
	mm	PN 10	PN 16	PN 25	PN 40-100
DN 50	43	102	102	102	102
DN 80	49	138	138	138	138
DN 100	56	158	158	162	162
DN 150	70	212	212	218	218
DN 200	71	268	268	278	285
DN 250	76	320	320	335	345
DN 300	83	370	378	395	410

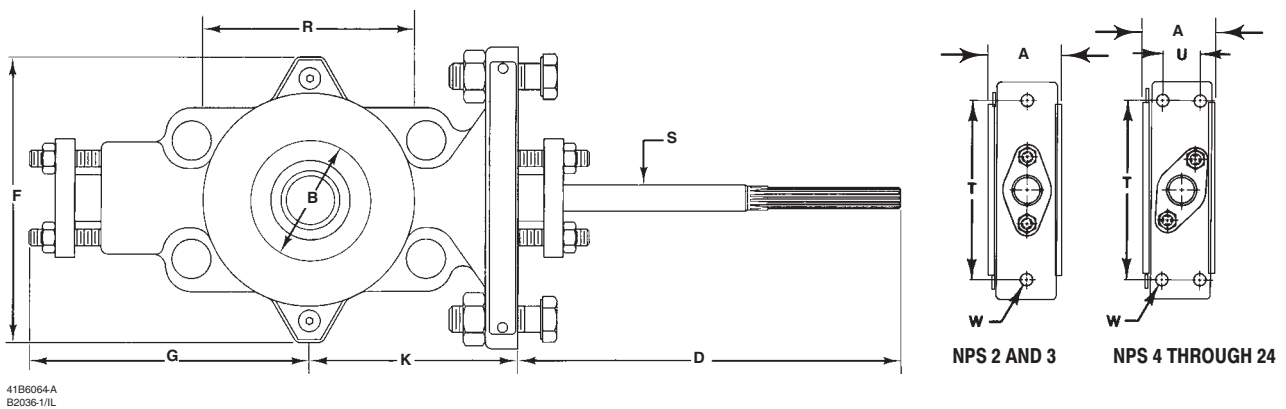

Figure 9. Dimensions for Fisher 8510 and 8510B (also see tables 12 and 13)

Table 14. Dimensions for Fisher 8510B with Alternate Double D Shaft

VALVE SIZE, NPS	A	B	D	F	G	K	R	S (SHAFT DIA)	T	U	W	APPROXIMATE WEIGHT <sup>(1)</sup>
	mm											kg
2	45	59	---	141	138	102	103	---	117	---	1/2-13	4.3
3	48	78	83	168	155	119	127	12.7	117	---	1/2-13	5.9
4	54	102	83	197	198	162	159	15.7	152	32	1/2-13	9.1
6	57	141	83	251	238	202	217	19.0	152	32	1/2-13	19
8	64	191	83	317	289	244	272	25.4	235	46	5/8-11	31
10	71	241	89	378	289	257	325	31.8	235	46	5/8-11	46
12	83	286	89	438	348	297	384	38.1	235	46	5/8-11	72
Inches												Pounds
2	1.78	2.31	---	5.56	5.44	4.00	4.06	---	4.62	---	1/2-13	9.5
3	1.88	3.06	3.25	6.62	6.12	4.69	5.00	0.5	4.62	---	1/2-13	13
4	2.12	4.00	3.25	7.75	7.81	6.38	6.25	0.625	6.00	1.25	1/2-13	20
6	2.25	5.56	3.25	9.88	9.38	7.94	8.53	0.75	6.00	1.25	1/2-13	41
8	2.50	7.50	3.25	12.50	11.38	9.62	10.69	1	9.25	1.81	5/8-11	69
10	2.81	9.50	3.50	14.88	11.38	10.12	12.81	1.25	9.25	1.81	5/8-11	102
12	3.19	11.25	3.50	17.25	13.69	11.69	15.12	1.5	9.25	1.81	5/8-11	158

1. Valve assembly only.

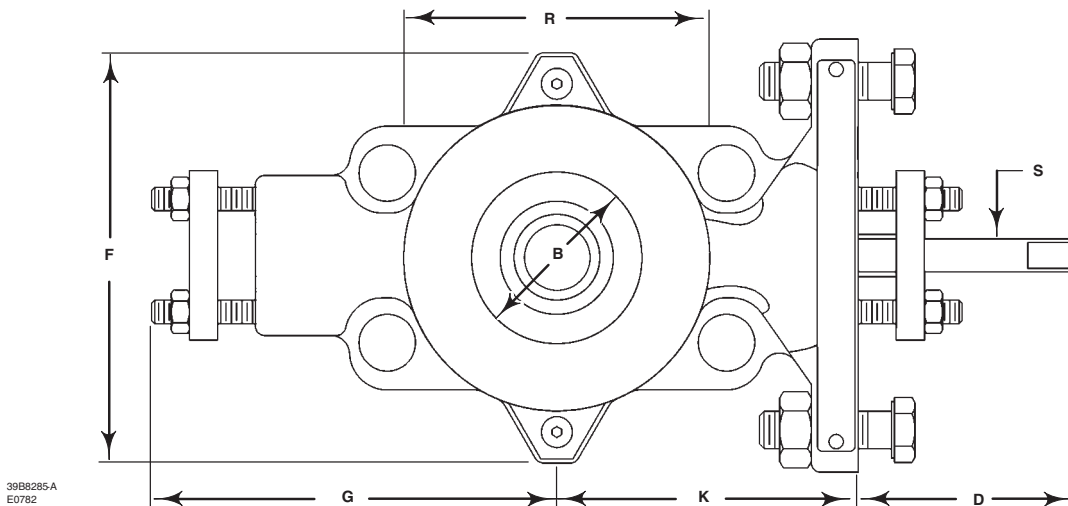

Figure 10. Dimensions for Fisher 8510B with Alternate Double D Shaft (also see table 14)

## Note

**Neither Emerson, Emerson Process Management, nor any of their affiliated entities assumes responsibility for the selection, use, or maintenance of any product. Responsibility for the selection, use, and maintenance of any product remains with the purchaser and end user.**

Fisher and ENVIRO-SEAL are marks owned by one of the companies in the Emerson Process Management business division of Emerson Electric Co. Emerson Process Management, Emerson, and the Emerson logo are trademarks and service marks of Emerson Electric Co. All other marks are the property of their respective owners.

The contents of this publication are presented for informational purposes only, and while every effort has been made to ensure their accuracy, they are not to be construed as warranties or guarantees, express or implied, regarding the products or services described herein or their use or applicability. All sales are governed by our terms and conditions, which are available upon request. We reserve the right to modify or improve the designs or specifications of such products at any time without notice. Neither Emerson, Emerson Process Management, nor any of their affiliated entities assumes responsibility for the selection, use or maintenance of any product. Responsibility for proper selection, use, and maintenance of any product remains solely with the purchaser and end user.

### **Emerson Process Management**

Marshalltown, Iowa 50158 USA  
Sorocaba, 18087 Brazil  
Chatham, Kent ME4 4QZ UK  
Dubai, United Arab Emirates  
Singapore 128461 Singapore

[www.Fisher.com](http://www.Fisher.com)

