

Type 8510 and 8510B Eccentric Disc Control Valves (EMA)

The Type 8510 and 8510B ēdisc® valves feature an eccentrically mounted disc and a PTFE or 316 stainless steel seal ring. The pressure-assisted seal ring provides excellent shutoff against pressure applied in either direction. Type 8510B is a multi-class rated valve, available in 2- through 12-inch sizes, and PN10 through PN100 compatible (compatibility varies with size and class, see table 1).

Type 8510 is rated for Class 150, available in 14- through 24-inch sizes, and PN10 and PN16 compatible (compatibility varies with size and class, see table 1). These valves combine with a variety of power and manual actuators to form reliable, high-performance control valves suited for many liquid and gas applications requiring extremely low leakage. Constructions are available for temperatures up to 538°C (1000°F).



W4739-2/IL

Figure 1. Eccentric Disc Control Valve with Type 1052 Actuator and Type 3610J Positioner



W8326

Figure 2. Type 8510B with Alternate Double D Shaft and Type 1035 Actuator



Specifications

Valve Sizes (DIN Flange Compatibility) and End Connection Style

Type 8510B: ■ 2, ■ 4, ■ 6 and ■ 8 (PN10 through PN100) – Class 150, 300 or 600 ANSI flange compatibility, ■ 10 and ■ 12-inch (PN10 through PN40) – Class 150 ANSI flange compatibility

Type 8510 flangeless valves: ■ 14 (PN10 and PN16), ■ 16 (PN16), ■ 18, ■ 20 (PN16) and ■ 24-inch (PN16) – Class 150 ANSI flange compatibility for size 14- through 24-inch

Also see table 1.

Maximum Inlet Pressures⁽¹⁾

WCC Steel, CF3M Stainless Steel (316L SST), and CN7M (Alloy 20) Valve Bodies: Consistent with applicable pressure-temperature ratings in table 2, unless limited by pressure drop/temperature capabilities in tables 6, 7, 8, 9 and 10 or temperature capabilities in table 11.

M35-1 (Monel) Valve Bodies: As shown in table 2, unless further limited by pressure drop/temperature capabilities in table 10 or temperature capabilities in table 11.

Maximum Pressure Drops⁽¹⁾

Steel Valve Bodies (Type 8510 and 8510B): See table 6 or 7.

CF8M Stainless Steel Valve Bodies (Type 8510): See tables 8 and 9.

Alloy Valve Bodies (Type 8510B): See table 10.

Shutoff Classifications per ANSI/FCI 70-2 and IEC 60534-4

PTFE Seal Ring: Bidirectional shutoff to Class VI is standard

316 Stainless Steel Seal Ring: 0.001% of maximum valve capacity (one tenth of Class IV)

Construction Materials

See tables 3, 4 and 5

Material Temperature Capabilities⁽¹⁾

See table 11

Flow Characteristic

Approximately linear

Flow Direction

Standard (forward flow) is with the seal retainer facing upstream; reverse flow is permissible within specified limitations

Flow Coefficients

See table 1

Flow Coefficient Ratio⁽²⁾

100 to 1

Noise Levels

See Catalog 12 for sound pressure level prediction

Disc Rotation

Clockwise to close (when viewed from actuator side of valve) through 90 degrees of disc rotation

Actuator Valve Action

With diaphragm or piston rotary actuator, field-reversible between ■ push-down-to-open (extending actuator rod opens valve) and ■ push-down-to-close (extending actuator rod closes valve)

With Type 1035 Rack and Pinion actuator with spring return or double acting action, field-reversible between ■ fail-to-open and ■ fail-to-close

Valve Classification

■ Face-to-face dimensions of 3- through 6-inch sizes in Class 150 and 300, and face-to-face dimensions of 8- through 24-inch sizes in Class 150, meet API 609 standards for face-to-face dimensions of narrow flangeless and single-flange valves

■ DIN face-to-face dimensions for all sizes meet DIN 3202 Part 3/K2, and

■ JIS B2210 standard face-to-face dimensions are available on request.

(continued)

Specifications (continued)

Mating Flange Capabilities

All size compatible with welding-neck and slip-on flanges (schedule 80 or lighter for Type 8510B 2- through 12-inch sizes; schedule 40 or lighter for Type 8510 14- through 24-inch sizes)

Shaft Diameters and Approximate Weights

See figures 9 and 10

Options

■ Line flange bolting, ■ FGM line flange gaskets

1. The pressure/temperature limits in this bulletin and any applicable standard or code limitation should not be exceeded.
2. Ratio of maximum flow coefficient to minimum useable flow coefficient.

Features

● **Sour Gas Service Capability**—Trim and bolting materials are available for applications involving sour fluids and gases. These constructions comply with the requirements of NACE MR0175.

● **Excellent Flow Control**—The eccentrically mounted disc design provides an approximately linear flow characteristic and can be used for on/off or throttling control applications through 90 degrees of disc rotation. Optional disc stop on Type 8510B provides seal protection.

● **Improved Environmental Capabilities**—The optional ENVIRO-SEAL® packing systems, shown in figure 8, are designed with very smooth stem surfaces, and live loading provides improved sealing, guiding, and loading force transmission. The

seal of the ENVIRO-SEAL system can control emissions to below the EPA (Environmental Protection Agency) limit of 500 ppm (parts per million) for valves.

● **Lost Motion Minimized**—For Type 8510, the taper pin/disc connection and the splined valve shaft with clamped lever and single pivot linkage reduce lost motion between the actuator and valve. For Type 8510B, the taper key/disc connection and the splined valve shaft with clamped lever and single pivot linkage reduce lost motion between the actuator and valve.

● **Greater Capacities and Lower Operating Torques**—The contoured disc increases flow capacity and reduces operating torque at peak angles of disc opening.

ENVIRO-SEAL Packing System Specifications

Available Packing

- ENVIRO-SEAL PTFE Packing System
- ENVIRO-SEAL Graphite Packing System

Maximum Temperature/Pressure Limits⁽¹⁾

Maximum Application Temperature/Pressure Limits to meet EPA Fugitive Emission Standard of 500 ppm⁽²⁾:

For ENVIRO-SEAL PTFE Packing Systems: Up to 232°C (450°F) at the ANSI class rating of the valve.

For ENVIRO-SEAL Graphite Packing Systems: Up to 316°C (600°F) at the ANSI class rating of the valve

Material Temperature Range:

For ENVIRO-SEAL PTFE Packing Material:
–46 to 232°C (–50 to 450°F)

For ENVIRO-SEAL Graphite Packing Material:
Up to 316°C (600°F)

Construction Materials⁽³⁾

PTFE Packing Systems:

Packing Rings: PTFE V-ring⁽⁴⁾.

Male and Female Adaptor Rings: Carbon-filled PTFE V-ring

Anti-Extrusion Rings: High strength polymer

Packing Box Rings: S31600 (316 SST)

Graphite Packing Systems:

Packing Rings: Graphite

Anti-Extrusion Rings: Carbon

Packing Box Rings: S31600 (316 SST)

Spring Pack Components:

O-Ring: Nitrile. Here, the O-ring serves as an assembly convenience to hold the springs in position on the follower.

Packing Follower: S31600 with carbon-filled PTFE liner

Springs: N07718 (Inconel 718)

Packing Flange: S31600 (316 SST)

Packing Box Studs: Strain-hardened S31600, SA-193-B8M

Packing Box Nuts: S31600 SA-194-8M

1. The pressure/temperature limits in this bulletin and any applicable standard or code limitation for valve should not be exceeded.

2. The Environmental Protection Agency (EPA) has set a limit of 500 parts per million (ppm) for fugitive emissions from a valve.

3. For other materials of construction, see table 3.

4. In vacuum service it is not necessary to reverse the ENVIRO-SEAL PTFE packing rings.

Construction Features

- **Field-Reversible Valve Action**—The actuator/valve assembly action can be converted from push-down-to-open to push-down-to-close, or vice versa, without additional parts.

- **Integral Shaft-to-Body Bonding**—Standard valve construction includes conductive packing to provide electrical bonding for hazardous area applications.

- **Easy Installation**—Centering holes (figures 3, 4 and 5) engage the line flange bolts to simplify installation and provide for centering of the valve in the pipeline.

- **Longer Seal Life**—The opening and closing path of the eccentric disc (figure 6) minimizes disc contact with the seal ring, thereby reducing seal wear, undue friction, and seating torque requirements.

- **Exceptional Shutoff at High Pressure Drops**—Both the patented 316 stainless steel seal

ring and the patented bidirectional PTFE seal ring with pressure-assisting sealing action (figure 7) are designed to provide shutoff regardless of flow direction.

- **Reliable Flange Gasketing Surface**—The seal retainer cap screws or retention clips are outside the gasket surface of the seal retainer, and spiral wound or flat sheet gaskets can be installed between the uninterrupted seal retainer face and the pipeline flange.

- **Self-Flushing Action**—With standard right-hand actuator mounting, the bottom edge of the disc opens downstream away from the seal, and the flow stream flushes sediment from the seal.

- **Double D Shaft**—8510B valves in sizes 2 through 12-inch are available with double D shaft end designed to accept the Type 1035 Rack and Pinion Actuator and other quarter-turn actuators.

- **Shaft Retention**—Redundant shaft protection is provided with 8510B valves with the double D drive shaft. The packing follower and stepped shaft interact to provide the redundant shaft retention.

Product Bulletin

51.6:edisc (EMA)
August 2004

8510/8510B Valve

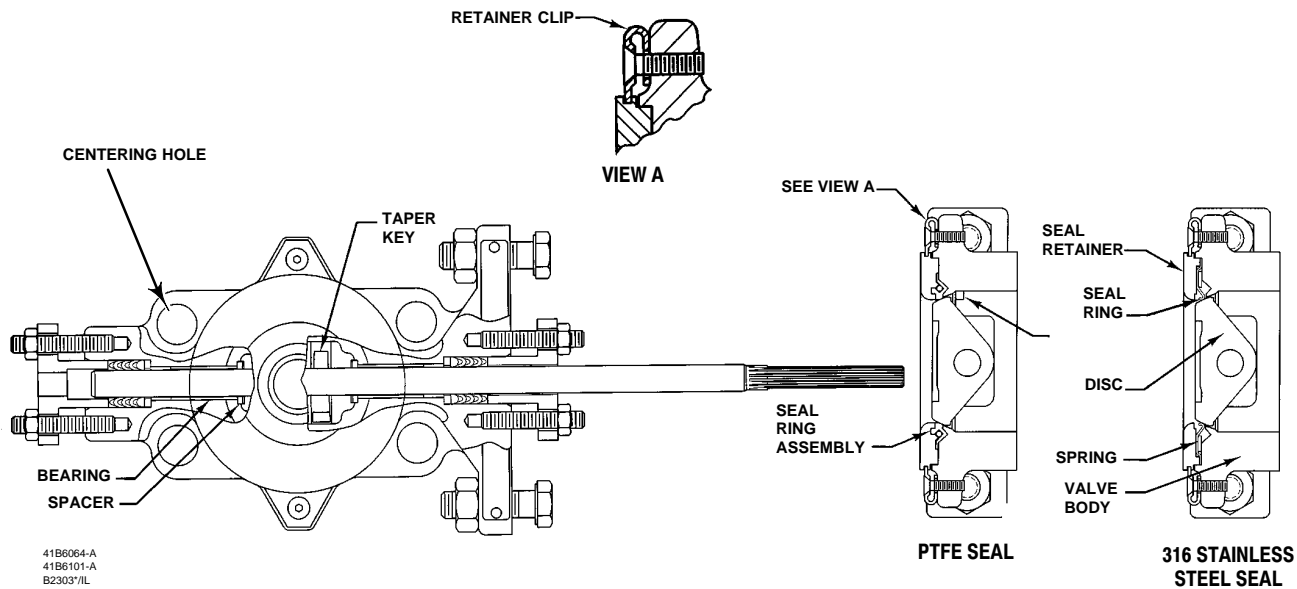

Figure 3. Typical Type 8510B Construction Detail

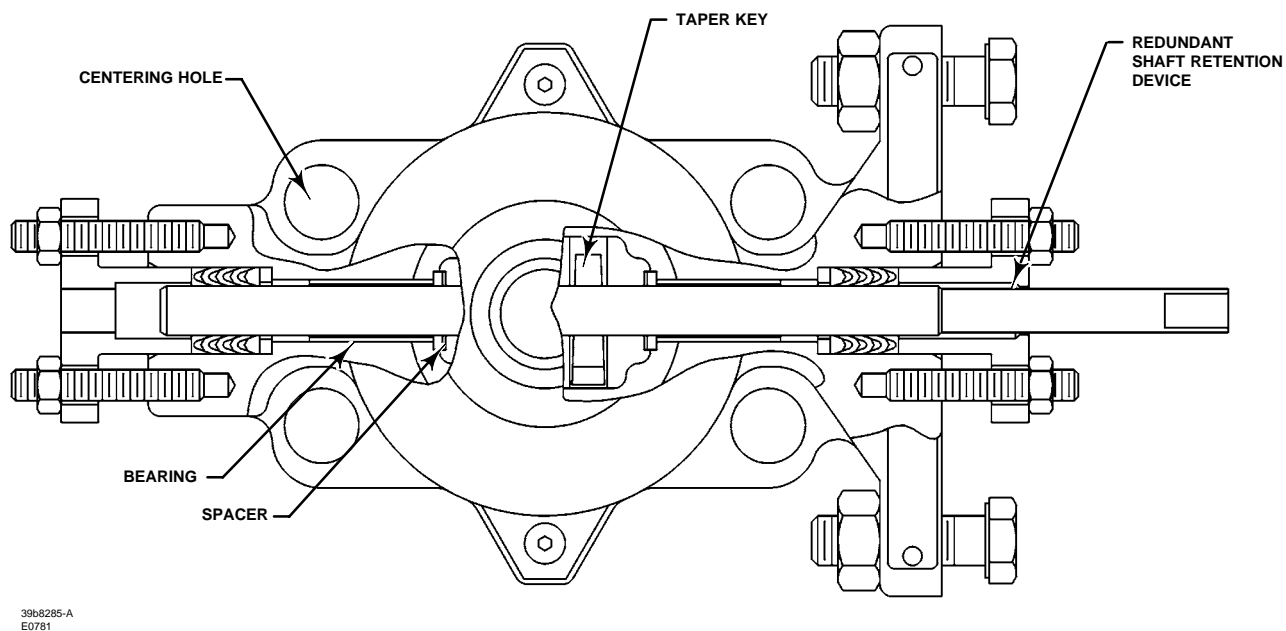

Figure 4. Typical Type 8510B Construction Detail with Double D Shaft

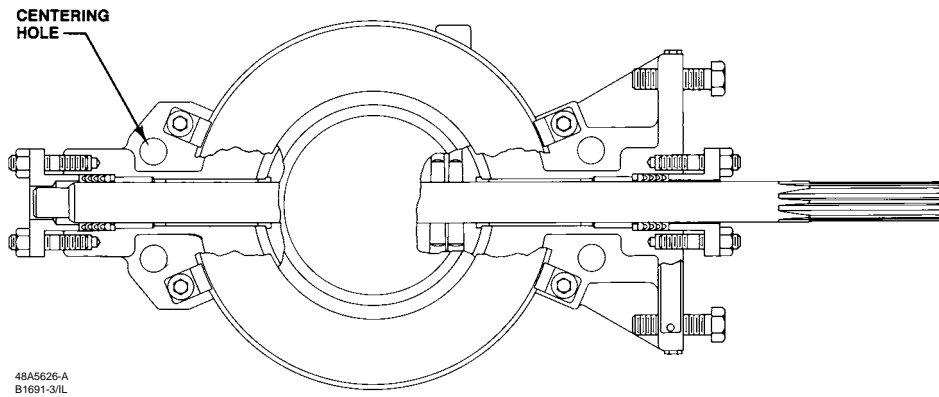
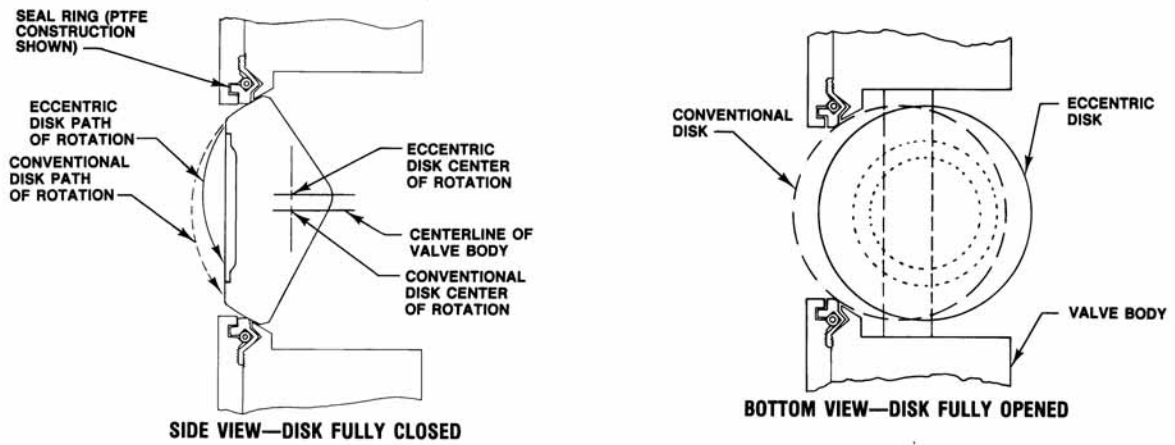

Figure 5. Construction of Type 8510



A2867-2/IL

Figure 6. Comparison of Disc Action

Product Bulletin

51.6:edisc (EMA)
August 2004

8510/8510B Valve

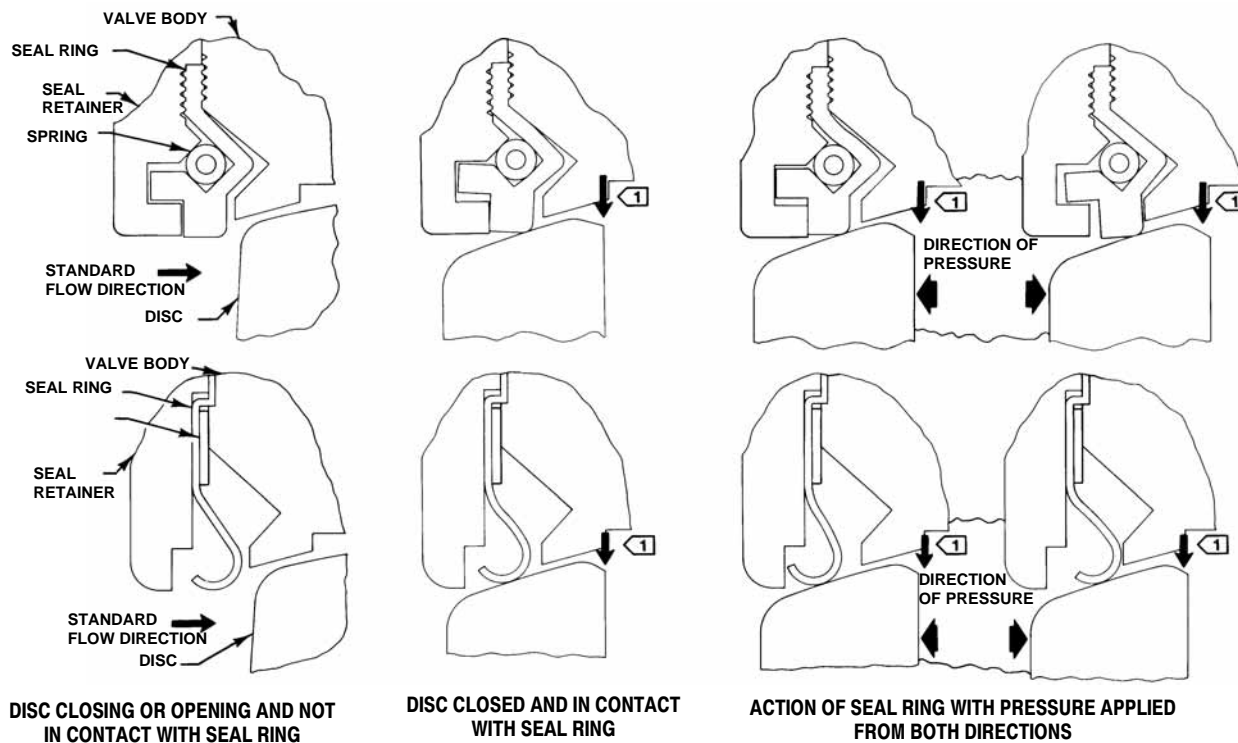

NOTE:

1 ARROW INDICATES DISC POSITION WITH NO PRESSURE

B1558-3/L

Figure 7. Action of Bidirectional PTFE Seal Ring (Top) and Metal Seat Ring (Bottom)

8510/8510B Valve

Material Selection Guidelines

Pick the valve body, trim, and other construction materials from tables 3, 4, and 5, according to the recommendations and limitations in tables 6, 7, 8, 9, 10, and 11. Also, make sure that the pressure/temperature limits in the specifications table and tables 1, 2, 6, 7, 8, 9, 10, and 11 are not exceeded.

NACE Standard MR0175 Compliance

Standard procurement procedures and manufacturing processes used by Fisher assure that control valves with sour service trim options will comply with the requirements of NACE MR0175. Incoming raw materials are selected for sour service trims by specifications covering chemical composition, forming, hardness, heat treatment, and finish. In addition, the subsequent machining, welding, and heat treatment of the materials being processed into finished parts is strictly regulated by manufacturing standards.

Due to strict start-to-finish manufacturing quality management, Fisher offers a high degree of confidence that the parts and assemblies provided for sour service will comply with MR0175. In cases where documentation is required, the following items can be provided:

- Hardness test data
- Certificate of compliance to specification

- Heat treatment documentation
- Chemical and physical test data

The requirements of MR0175 are very specific and the application of the standard to control valve materials is quite complex. There are, however, some general guidelines that are always followed:

- Martensitic and cast precipitation hardening stainless steel are not used.
- Control valve packings are jam style only.
- Primary trim materials are:

Type 8510: S20910 (Nitronic 50) stainless steel.

Type 8510B: S316L and S20910 (Nitronic 50) stainless steel.

- No machining operations that cause work hardening of the materials are performed in the manufacturing process.

- Platings and coatings are used only over suitable base metals and are not intended for corrosion protection.

- Standard bolting meets NACE MR0175 requirements for non-exposed bolting. Bolting meeting NACE MR0175 requirements for exposed bolting is available as an option.

Product Bulletin

51.6:edisc (EMA)
August 2004

8510/8510B Valve

Table 1. Flow Coefficients and ANSI Rating and Flange Compatibility

VALVE BODY SIZE, INCHES	C _v WITH NORMAL FLOW AND DISC WIDE OPEN (90 DEGREES ROTATION)	ANSI RATING COMPATIBILITY—STEEL, STAINLESS STEEL, AND ALLOY 20 VALVE BODIES	VALVE DESIGNATION—M35-1 (MONEL) ⁽¹⁾	ANSI FLANGE COMPATIBILITY	DIN FLANGE COMPATIBILITY
Type 8510B					
2	91.7	Class 150, 300, and 600	150/300/600	Class 150, 300, and 600	PN10, PN16, PN25, PN40, PN63 and PN100
3	232				
4	459				
6	907				
8	1740				
10	3570	Class 150 Class 300	150 300	Class 150 Class 300	PN10 and PN16 PN25 and PN40
12	4880	Class 150 Class 300	150 300	Class 150 Class 300	PN10 and PN16 PN25 and PN40
Type 8510					
14	7040	Class 150	—	Class 150	PN10 and PN16 ⁽²⁾
16	9650				PN16 ⁽²⁾
18	12,100				—
20	14,500				PN16 ⁽²⁾
24	21,800				PN16 ⁽²⁾
<p>1. Monel valve bodies are not included in ASME B16.34. See table 2 for pressure/temperature information for Monel valve bodies. The designations 150, 300, and 600 for these valve bodies are used only to indicate relative pressure-retaining capabilities and are not ANSI pressure/temperature rating class designations.</p> <p>2. Consult your Fisher sales office for pressure/temperature ratings of these valves.</p>					

Table 2. Maximum Allowable Inlet Pressures for M35-1 Valve Bodies⁽¹⁾

TEMPERATURE	MONEL 411 M35-1 ⁽¹⁾		
	150 ⁽¹⁾	300 ⁽¹⁾	600 ⁽¹⁾
°C	Bar		
-46 to 38	15.8	41.3	82.7
93	13.8	36.5	72.7
149	13.1	34.1	68.2
204	12.7	33.1	65.8
232	12.3	33.0	65.7
°F	Psig		
-50 to 100	230	600	1200
200	200	530	1055
300	190	495	990
400	185	480	955
450	178	478	953
<p>1. This material is not listed in ASME B16.34. Also see the installation information. The designations 150, 300, and 600 are used only to indicate relative pressure-retaining capabilities and are not ANSI pressure-temperature rating class designations.</p>			

8510/8510B Valve

Table 3. Standard Construction Materials

Part		Material
Valve Body ⁽¹⁾		<p>Type 8510: WCC Steel, CG8M (316 stainless steel), Monel 411 M35-1⁽²⁾, or CN-7M (alloy 20)</p> <p>Type 8510B: WCC Steel, CF3M (316L SST), M35-1⁽²⁾ (Monel), CN7M (alloy 20), 1.0619 (DIN 17245), or 1.4581 (DIN 17445)</p>
Disc ⁽¹⁾		<p>Type 8510: WCC Steel (A216), S31603 (316L stainless steel) (both with chrome-plated seating surfaces), Monel 411 M35-1, or alloy 20 CN-7M</p> <p>Type 8510B: WCC Steel (A216), M35-1 (Monel), CN7M (alloy 20), S31603 (316L SST), or Cr PI S31603 (Cr PI 316L SST)</p>
Seal ⁽¹⁾		PTFE with 316 stainless steel, Monel, or alloy 20 spring
		316 stainless steel seal and backup rings with graphite gaskets bonded to them
Bearings ⁽¹⁾	Lined	<p>Type 8510: PTFE⁽³⁾/composition lined w/SST jacket, PTFE⁽³⁾ composition lined w/S31600 (316 SST) jacket, S44004 (440C SST), alloy 6B, silver-plated alloy 6B, filled PTFE⁽⁴⁾ w/N04400 (Monel) jacket, or filled PTFE⁽⁴⁾ w/N08020 (alloy 20) jacket</p> <p>Type 8510B: PTFE⁽³⁾/composition lining with S31603 (316L SST), PTFE⁽⁴⁾ with S31603 jacket, filled PTFE⁽⁴⁾ with N04400 (monel) jacket, and filled PTFE⁽⁴⁾ with N08020 (alloy 20) jacket</p>
	All-metal	440C stainless steel, alloy 6B, or silver-plated alloy 6B
Type 8510: Valve shaft ⁽¹⁾ and bearing spacers		S17400 (17-4PH SST), S20910 (Nitronic 50 SST), Monel, or alloy 20
Type 8510B: Valve Shaft ⁽¹⁾⁽⁶⁾		S17400 (17-4PH), S20910 (Nitronic 50), N05500 (Monel K500), N08020 (alloy 20), or S31603 (316L SST)
Type 8510B: Bearing Spacers		PTFE/S31603 (316L SST), S17700 (17-7 PH SST), alloy 6B, PTFE/N04400 (monel), and PTFE/N08020 (alloy 20)
Type 8510: Taper Pins Type 8510B: Taper Keys	S17400 (17-4PH) and S20910 (Nitronic 50 stainless steel) shafts	<p>Type 8510: S20910</p> <p>Type 8510B: S20910 (Nitronic 50) SST, N05500 (Monel K500), N10276 (alloy 276), or N08020 (alloy 20)</p>
	Alloy shafts	Same material as shaft
Type 8510: Bearing stops (for metal bearings and non-alloy valve bodies only)	Steel valve bodies	S17400
	CF8M steel valve bodies	S31600 (316 stainless steel)
Type 8510B: Bearings stops (for metal bearings and non-alloy valves only)		S31600 (316 SST)
Seal retainer		Same material as valve body
Packing arrangements		Standard packing is available with PTFE packing V-rings with one carbon-filled PTFE conductive ring, PTFE-composition rings with one graphited conductive ring, and preformed graphite ribbon rings. ENVIRO-SEAL packing system is available with PTFE V-rings with one carbon-filled PTFE conductive ring or with graphite packing rings.
Packing followers and packing box rings		S31600, Monel, or alloy 20
Packing flanges, studs and nuts		Plated steel, S31603 ⁽⁵⁾ , S31600, CF8M, Monel, or alloy 20

1. See table 4 for acceptable trim material combinations.
2. This is not an ASME B16.34 or ASME code-approved material. Also see the Installation section.
3. Reinforced PTFE in phenolic resin. Fisher designation is FMS 30B4.
4. PTFE with selected fillers. Fisher designation is FMS 30B5.
5. S31603 is available for 8510B only
6. Type 8510B valve shafts with Double D end are available only in 17-4PH SST, 316L SST of Nitronic 50.

Product Bulletin

51.6:edisc (EMA)
August 2004

8510/8510B Valve

Table 4. Trim Combinations with Standard Construction Materials

Disc Material	Shaft Material	Bearing Material	Seal Material	Acceptable Valve Body Material	Trim Number
Type 8510: WCC steel with chrome-plated seating surfaces Type 8510B: WCC steel with chrome-plated seating surface or S31603 (316L SST) ⁽¹⁾	S17400 (17-4PH stainless steel)	PTFE/composition-lined, w/SST jacket	PTFE	Steel	1
			316 stainless steel		5
		S44004 (440C SST)	316 stainless steel		9
Type 8510: S31603 (316L SST) with chrome-plated seating surfaces Type 8510B: S31603 (316L SST) with chrome-plated seating surfaces or S31603 (316L SST) without plating with PTFE seal only	S17400	PTFE/composition-lined w/SST jacket	PTFE	Steel	2
			316 stainless steel		6
		PTFE/composition-lined S31600 (316 SST) jacket	PTFE	Type 8510: Steel or CF8M Type 8510B: Steel or CF3M (316 SST)	4
			316 stainless steel		8
		S44004	316 stainless steel	Steel	10
		Silver-plated alloy 6B	316 stainless steel	Type 8510: Steel or, CF8M Type 8510B: Steel or CF3M (316 SST)	12
	Alloy 6B	316 stainless steel	14		
	S20910 (Nitronic 50 stainless steel)	PTFE/composition-lined with S31600 jacket	PTFE	Type 8510: Steel or CF8M Type 8510B: Steel or CF3M (316 SST)	3
			316 stainless steel		7
			Silver-plated alloy 6B		11
		Alloy 6B	316 stainless steel	13	
	Monel 411 M35-1	N05500 (Monel K500)	Filled PTFE ⁽²⁾ w/ N04400 (Monel) jacket	PTFE	Monel 411 M35-1 or steel
Alloy 20 CN-7M	Alloy 20	Filled PTFE ⁽²⁾ w/ N08020 (alloy 20) jacket	PTFE	Alloy 20 CN-7M	17 ⁽³⁾⁽⁴⁾

1. Steel disc not available in the 2- and 3-inch valve body sizes.
 2. PTFE with selected fillers. Fisher designation is FMS 30B5.
 3. This trim not available in the Type 8510 14- through 24-inch valve body sizes.
 4. This trim not available with the Double D shaft version of the 8510B.

Table 5. Trim NT3 Part Materials for Compliance with NACE MR0175 (Sour Service) Specifications

Valve Body	Disc	Seal	Bearings	Valve Shaft	Taper Pins	Packing	Packing Followers and Packing Box Rings	Packing Flanges	Packing Flange Bolting
Type 8510: Steel or CF8M (316 stainless steel) Type 8510B: Steel or CF3M (316L SST)	Type 8510: CG8M (317 stainless steel) with chrome-plated seating surfaces Type 8510B: S31603 (316 SST) with chrome-plated seating surfaces or S31603 (316L SST)	PTFE seal with N05500 (Monel K500) spring	Type 8510: Filled PTFE w/ S31600 (316 SST) jacket Type 8510B: PTFE/composition-lined S31603 (316L SST)	S20910 (Nitronic 50 stainless steel)	S20910 (Nitronic 50 stainless steel)	PTFE V-ring with one carbon-filled PTFE conductive packing ring	Type 8510: S31600 (316 stainless steel) Type 8510B: S31600 (316 SST) or S31603 (316L SST)	Type 8510: steel Type 8510B: S31600 (316 SST) or S31603 (316L SST)	Grade B7 steel studs and Grade 2H steel nuts

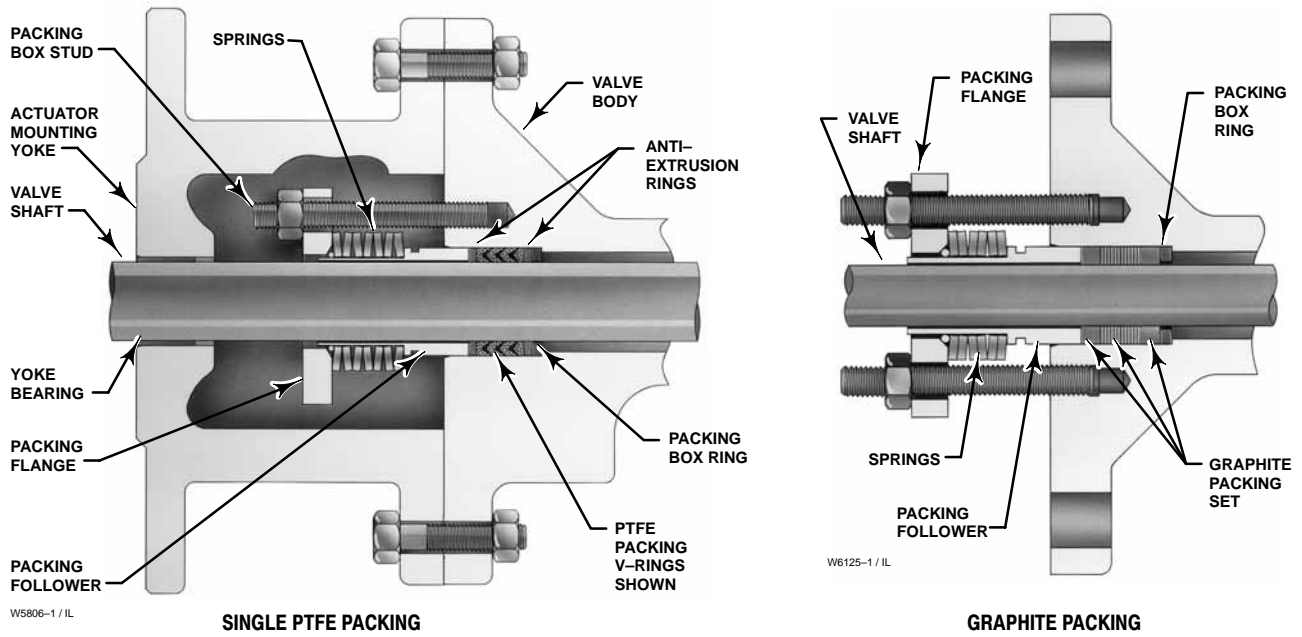

Figure 8. Typical ENVIRO-SEAL Packing Arrangements for Rotary Valves

Product Bulletin

51.6:edisc (EMA)
August 2004

8510/8510B Valve

Table 6. Maximum Allowable Shutoff Pressure Drops⁽¹⁾ in Bar for Steel Valve Body Material

TABLE 4 OR 5 TRIM NUMBER	FLOW DIRECTION	TEMP. °C	MAX ALLOWABLE SHUTOFF ΔP (PER VALVE BODY SIZE, INCHES)												
			Type 8510B						Type 8510						
			2	3	4	6	8	10	12	14	16	18	20	24	
1 ⁽²⁾ , 2, 3, 4, NT3	Forward or reverse	-29 to 49	56.2	64.5	53.8	57.9	54.6	37.7	41.4	19.7	19.7	19.7	19.7	19.7	
		66	56.2	58.5	53.8	57.9	54.6	37.7	41.4	19.0	19.0	19.0	19.0	19.0	
		93	48.5	48.5	48.5	48.5	48.5	37.7	41.4	17.9	17.9	17.9	17.9	17.9	
		121	38.6	38.6	38.6	38.6	38.6	37.7	38.6	16.9	16.9	16.9	16.9	16.9	
		149	28.7	28.7	28.7	28.7	28.7	28.7	28.7	15.5	15.5	15.5	15.5	15.5	
		191	13.8	13.8	13.8	13.8	13.8	13.8	13.8	13.8	13.8	13.8	13.8	13.8	13.8
		204	10.3	10.3	10.3	10.3	10.3	10.3	10.3	10.3	10.3	10.3	10.3	10.3	10.3
		232 ⁽³⁾	3.4	3.4	3.4	3.4	3.4	3.4	3.4	3.4	3.4	3.4	3.4	3.4	
5 ⁽²⁾ , 6, 7, 8	Forward	-29 to 232 ⁽³⁾	51.0	51.0	51.0	51.0	31.0	17.2	17.2	10.3	10.3	10.3	10.3	10.3	
	Reverse	-29 to 232 ⁽³⁾	6.9	6.9	6.9	6.9	6.9	6.9	6.9	6.9	6.9	6.9	6.9	6.9	
9 ⁽²⁾ , 10	Forward or reverse	-29 to 149	19.7 ⁽⁴⁾	31.5 ⁽⁴⁾	28.8 ⁽⁴⁾	20.2 ⁽⁴⁾	24.3 ⁽⁴⁾	13.4 ⁽⁴⁾	9.0 ⁽⁴⁾	5.3	10.0 ⁽⁴⁾	6.4	3.8	7.9 ⁽⁴⁾	
		204	18.2 ⁽⁴⁾	29.9 ⁽⁴⁾	27.4 ⁽⁴⁾	20.2 ⁽⁴⁾	24.3 ⁽⁴⁾	12.8 ⁽⁴⁾	8.5 ⁽⁴⁾	4.9	9.5 ⁽⁴⁾	6.1	3.5	7.5 ⁽⁴⁾	
		260	17.3 ⁽⁴⁾	28.9 ⁽⁴⁾	26.5 ⁽⁴⁾	19.6 ⁽⁴⁾	24.3 ⁽⁴⁾	12.3 ⁽⁴⁾	8.2 ⁽⁴⁾	4.7	9.2 ⁽⁴⁾	5.8	3.3	7.3 ⁽⁴⁾	
		316	16.8 ⁽⁴⁾	28.3 ⁽⁴⁾	26.0 ⁽⁴⁾	19.2 ⁽⁴⁾	24.0 ⁽⁴⁾	12.1 ⁽⁴⁾	8.1 ⁽⁴⁾	4.6	9.0 ⁽⁴⁾	5.7	3.2	7.2 ⁽⁴⁾	
		371	15.9 ⁽⁴⁾	27.3 ⁽⁴⁾	25.1 ⁽⁴⁾	18.6 ⁽⁴⁾	23.3 ⁽⁴⁾	11.7 ⁽⁴⁾	7.7 ⁽⁴⁾	4.3	8.8 ⁽⁴⁾	5.4	3.0	7.0 ⁽⁴⁾	
		427	15.0 ⁽⁴⁾	26.3 ⁽⁴⁾	24.2 ⁽⁴⁾	17.9 ⁽⁴⁾	22.6 ⁽⁴⁾	11.2 ⁽⁴⁾	7.4 ⁽⁴⁾	4.1	8.4 ⁽⁴⁾	5.2	2.8	6.7 ⁽⁴⁾	
11	Forward or reverse	-29 to 93	19.7 ⁽⁴⁾	21.9 ⁽⁴⁾	18.5 ⁽⁴⁾	17.0 ⁽⁴⁾	14.6 ⁽⁴⁾	9.1 ⁽⁴⁾	9.0 ⁽⁴⁾	5.2	7.4 ⁽⁴⁾	5.7	3.7	6.7	
		149	17.1 ⁽⁴⁾	21.9 ⁽⁴⁾	18.5 ⁽⁴⁾	17.0 ⁽⁴⁾	14.6 ⁽⁴⁾	9.1 ⁽⁴⁾	8.1 ⁽⁴⁾	4.6	7.4 ⁽⁴⁾	5.7	3.2	6.7	
		204	15.0 ⁽⁴⁾	21.9 ⁽⁴⁾	18.5 ⁽⁴⁾	17.0 ⁽⁴⁾	14.6 ⁽⁴⁾	9.1 ⁽⁴⁾	7.4 ⁽⁴⁾	4.1	7.4 ⁽⁴⁾	5.2	2.8	6.7	
		260	14.6 ⁽⁴⁾	21.9 ⁽⁴⁾	18.5 ⁽⁴⁾	17.0 ⁽⁴⁾	14.6 ⁽⁴⁾	9.1 ⁽⁴⁾	7.2 ⁽⁴⁾	3.9	7.4 ⁽⁴⁾	5.1	2.8	6.6	
		316	13.9 ⁽⁴⁾	21.9 ⁽⁴⁾	18.5 ⁽⁴⁾	17.0 ⁽⁴⁾	14.6 ⁽⁴⁾	9.1 ⁽⁴⁾	7.0 ⁽⁴⁾	3.8	7.4 ⁽⁴⁾	4.9	2.6	6.4	
		371	13.3 ⁽⁴⁾	21.9 ⁽⁴⁾	18.5 ⁽⁴⁾	16.8 ⁽⁴⁾	14.6 ⁽⁴⁾	9.1 ⁽⁴⁾	6.8	3.7	7.4 ⁽⁴⁾	4.8	2.6	6.3	
		427	12.6 ⁽⁴⁾	21.9 ⁽⁴⁾	18.5 ⁽⁴⁾	16.3 ⁽⁴⁾	14.6 ⁽⁴⁾	9.1 ⁽⁴⁾	6.6	3.4	7.4 ⁽⁴⁾	4.6	2.3	6.1	
12	Forward or reverse	-46 to 149	19.7 ⁽⁴⁾	21.9 ⁽⁴⁾	18.5 ⁽⁴⁾	17.0 ⁽⁴⁾	14.6 ⁽⁴⁾	9.1 ⁽⁴⁾	9.0 ⁽⁴⁾	5.3	7.4 ⁽⁴⁾	5.7	3.8	6.7	
		204	18.2 ⁽⁴⁾	21.9 ⁽⁴⁾	18.5 ⁽⁴⁾	17.0 ⁽⁴⁾	14.6 ⁽⁴⁾	9.1 ⁽⁴⁾	8.5 ⁽⁴⁾	4.9	7.4 ⁽⁴⁾	5.7	3.5	6.7	
		260	17.3 ⁽⁴⁾	21.9 ⁽⁴⁾	18.5 ⁽⁴⁾	17.0 ⁽⁴⁾	14.6 ⁽⁴⁾	9.1 ⁽⁴⁾	8.2 ⁽⁴⁾	4.7	7.4 ⁽⁴⁾	5.7	3.3	6.7	
		316	16.8 ⁽⁴⁾	21.9 ⁽⁴⁾	18.5 ⁽⁴⁾	17.0 ⁽⁴⁾	14.6 ⁽⁴⁾	9.1 ⁽⁴⁾	8.1 ⁽⁴⁾	4.6	7.4 ⁽⁴⁾	5.7	3.2	6.7	
		371	15.9 ⁽⁴⁾	21.9 ⁽⁴⁾	18.5 ⁽⁴⁾	17.0 ⁽⁴⁾	14.6 ⁽⁴⁾	9.1 ⁽⁴⁾	7.7 ⁽⁴⁾	4.3	7.4 ⁽⁴⁾	5.4	3.0	6.7	
		427	15.0 ⁽⁴⁾	21.9 ⁽⁴⁾	18.5 ⁽⁴⁾	17.0 ⁽⁴⁾	14.6 ⁽⁴⁾	9.1 ⁽⁴⁾	7.4 ⁽⁴⁾	4.1	7.4 ⁽⁴⁾	5.2	2.8	6.7	
13	Forward or reverse	-29 to 149	12.3 ⁽⁴⁾	11.0 ⁽⁴⁾	9.2 ⁽⁴⁾	8.5 ⁽⁴⁾	7.3 ⁽⁴⁾	4.6	4.6	3.5	3.7	2.8	3.0	3.3	
		204	12.3 ⁽⁴⁾	11.0 ⁽⁴⁾	9.2 ⁽⁴⁾	8.5 ⁽⁴⁾	7.3 ⁽⁴⁾	4.6	4.6	3.5	3.7	2.8	2.8	3.3	
		260	12.3 ⁽⁴⁾	11.0 ⁽⁴⁾	9.2 ⁽⁴⁾	8.5 ⁽⁴⁾	7.3 ⁽⁴⁾	4.6	4.6	3.5	3.7	2.8	2.8	3.3	
		316	12.3 ⁽⁴⁾	11.0 ⁽⁴⁾	9.2 ⁽⁴⁾	8.5 ⁽⁴⁾	7.3 ⁽⁴⁾	4.6	4.6	3.5	3.7	2.8	2.6	3.3	
		371	12.3 ⁽⁴⁾	11.0 ⁽⁴⁾	9.2 ⁽⁴⁾	8.5 ⁽⁴⁾	7.3 ⁽⁴⁾	4.6	4.6	3.5	3.7	2.8	2.6	3.3	
		427	12.3 ⁽⁴⁾	11.0 ⁽⁴⁾	9.2 ⁽⁴⁾	8.5 ⁽⁴⁾	7.3 ⁽⁴⁾	4.6	4.6	3.4	3.7	2.8	2.3	3.3	
14	Forward	-29 to 427	12.3	11.0	9.2	8.5	7.3	4.6	4.6	3.5	3.7	2.8	3.0	3.3	
	Reverse	-29 to 427	6.9	6.9	6.9	6.9	6.9	6.9	6.9	3.5	3.7	2.8	3.0	3.3	
15	Forward or reverse	-29 to 49	52.4	60.4	50.3	57.9	51.4	33.4	33.8						
		66	52.4	58.5	50.3	57.9	51.4	33.4	33.8						
		93	43.0	43.0	43.0	43.0	43.0	33.4	33.8						
		121	38.6	38.6	38.6	38.6	38.6	33.4	33.8						
		149	28.7	28.7	28.7	28.7	28.7	28.7	28.7						
		191	13.8	13.8	13.8	13.8	13.8	13.8	13.8						
		204	10.3	10.3	10.3	10.3	10.3	10.3	10.3						
		232	3.4	3.4	3.4	3.4	3.4	3.4							

1. Based on valve body assembly material strengths only—actuator torque not considered.
 2. This trim not available in the 2-, 3-, and 4-inch valve body sizes.
 3. For hot water or steam service, limit maximum temperature to 207°C.
 4. Reverse pressure drop is limited to 6.9 bar.

8510/8510B Valve

Table 7. Maximum Allowable Shutoff Pressure Drops⁽¹⁾ in Psi for Steel Valve Body Material

TABLE 4 OR 5 TRIM NUMBER	FLOW DIRECTION	TEMP. °F	MAX ALLOWABLE SHUTOFF ΔP (PER VALVE BODY SIZE, INCHES)											
			Type 8510B						Type 8510					
			2	3	4	6	8	10	12	14	16	18	20	24
1 ⁽²⁾ , 2, 3, 4, NT3	Forward or reverse	-20 to 120	816	935	780	840	792	547	600	285	285	285	285	285
		150	816	848	780	840	792	547	600	275	275	275	275	275
		200	704	704	704	704	704	547	600	260	260	260	260	260
		250	560	560	560	560	560	547	560	245	245	245	245	245
		300	416	416	416	416	416	416	416	230	230	230	230	230
		375	200	200	200	200	200	200	200	200	200	200	200	200
		400	150	150	150	150	150	150	150	150	150	150	150	150
		450 ⁽³⁾	50	50	50	50	50	50	50	50	50	50	50	
5 ⁽²⁾ , 6, 7, 8	Forward	-20 to 450 ⁽³⁾	740	740	740	740	450	250	250	150	150	150	150	150
	Reverse	-20 to 450 ⁽³⁾	100	100	100	100	100	100	100	100	100	100	100	100
9 ⁽²⁾ , 10	Forward or reverse	-20 to 300	285 ⁽⁴⁾	457 ⁽⁴⁾	417 ⁽⁴⁾	307 ⁽⁴⁾	353 ⁽⁴⁾	194 ⁽⁴⁾	131 ⁽⁴⁾	77	145 ⁽⁴⁾	93	55	115 ⁽⁴⁾
		400	264 ⁽⁴⁾	434 ⁽⁴⁾	397 ⁽⁴⁾	293 ⁽⁴⁾	353 ⁽⁴⁾	185 ⁽⁴⁾	124 ⁽⁴⁾	71	138 ⁽⁴⁾	88	51	109 ⁽⁴⁾
		500	251 ⁽⁴⁾	419 ⁽⁴⁾	384 ⁽⁴⁾	284 ⁽⁴⁾	353 ⁽⁴⁾	179 ⁽⁴⁾	119 ⁽⁴⁾	68	133 ⁽⁴⁾	84	48	106 ⁽⁴⁾
		600	244 ⁽⁴⁾	411 ⁽⁴⁾	377 ⁽⁴⁾	279 ⁽⁴⁾	348 ⁽⁴⁾	175 ⁽⁴⁾	117 ⁽⁴⁾	66	131 ⁽⁴⁾	83	47	104 ⁽⁴⁾
		700	231 ⁽⁴⁾	396 ⁽⁴⁾	364 ⁽⁴⁾	270 ⁽⁴⁾	338 ⁽⁴⁾	169 ⁽⁴⁾	112 ⁽⁴⁾	62	127 ⁽⁴⁾	79	44	101 ⁽⁴⁾
		800	218 ⁽⁴⁾	381 ⁽⁴⁾	351 ⁽⁴⁾	260 ⁽⁴⁾	328 ⁽⁴⁾	163 ⁽⁴⁾	107 ⁽⁴⁾	59	122 ⁽⁴⁾	78	41	97 ⁽⁴⁾
11	Forward or reverse	-20 to 200	285 ⁽⁴⁾	318 ⁽⁴⁾	268 ⁽⁴⁾	246 ⁽⁴⁾	212 ⁽⁴⁾	132 ⁽⁴⁾	130 ⁽⁴⁾	76	107 ⁽⁴⁾	82	54	97
		300	248 ⁽⁴⁾	318 ⁽⁴⁾	268 ⁽⁴⁾	246 ⁽⁴⁾	212 ⁽⁴⁾	132 ⁽⁴⁾	118 ⁽⁴⁾	67	107 ⁽⁴⁾	82	47	97
		400	218 ⁽⁴⁾	318 ⁽⁴⁾	268 ⁽⁴⁾	246 ⁽⁴⁾	212 ⁽⁴⁾	132 ⁽⁴⁾	107 ⁽⁴⁾	59	107 ⁽⁴⁾	75	41	97
		500	212 ⁽⁴⁾	318 ⁽⁴⁾	268 ⁽⁴⁾	246 ⁽⁴⁾	212 ⁽⁴⁾	132 ⁽⁴⁾	105 ⁽⁴⁾	57	107 ⁽⁴⁾	74	40	96
		600	201 ⁽⁴⁾	318 ⁽⁴⁾	268 ⁽⁴⁾	246 ⁽⁴⁾	212 ⁽⁴⁾	132 ⁽⁴⁾	102 ⁽⁴⁾	55	107 ⁽⁴⁾	71	38	93
		700	193 ⁽⁴⁾	318 ⁽⁴⁾	268 ⁽⁴⁾	246 ⁽⁴⁾	212 ⁽⁴⁾	132 ⁽⁴⁾	99	53	107 ⁽⁴⁾	69	37	91
		800	183 ⁽⁴⁾	318 ⁽⁴⁾	268 ⁽⁴⁾	236 ⁽⁴⁾	212 ⁽⁴⁾	132 ⁽⁴⁾	95	50	107 ⁽⁴⁾	66	34	88
12	Forward or reverse	-20 to 300	285 ⁽⁴⁾	318 ⁽⁴⁾	268 ⁽⁴⁾	246 ⁽⁴⁾	212 ⁽⁴⁾	132 ⁽⁴⁾	131 ⁽⁴⁾	77	107 ⁽⁴⁾	82	55	97
		400	264 ⁽⁴⁾	318 ⁽⁴⁾	268 ⁽⁴⁾	246 ⁽⁴⁾	212 ⁽⁴⁾	132 ⁽⁴⁾	124 ⁽⁴⁾	71	107 ⁽⁴⁾	82	51	97
		500	251 ⁽⁴⁾	318 ⁽⁴⁾	268 ⁽⁴⁾	246 ⁽⁴⁾	212 ⁽⁴⁾	132 ⁽⁴⁾	119 ⁽⁴⁾	68	107 ⁽⁴⁾	82	48	97
		600	244 ⁽⁴⁾	318 ⁽⁴⁾	268 ⁽⁴⁾	246 ⁽⁴⁾	212 ⁽⁴⁾	132 ⁽⁴⁾	117 ⁽⁴⁾	66	107 ⁽⁴⁾	82	47	97
		700	231 ⁽⁴⁾	318 ⁽⁴⁾	268 ⁽⁴⁾	246 ⁽⁴⁾	212 ⁽⁴⁾	132 ⁽⁴⁾	112 ⁽⁴⁾	62	107 ⁽⁴⁾	79	44	97
		800	218 ⁽⁴⁾	318 ⁽⁴⁾	268 ⁽⁴⁾	246 ⁽⁴⁾	212 ⁽⁴⁾	132 ⁽⁴⁾	107 ⁽⁴⁾	59	107 ⁽⁴⁾	75	41	97
13	Forward or reverse	-20 to 300	178 ⁽⁴⁾	159 ⁽⁴⁾	134 ⁽⁴⁾	123 ⁽⁴⁾	106 ⁽⁴⁾	66	67	51	53	41	44	48
		400	178 ⁽⁴⁾	159 ⁽⁴⁾	134 ⁽⁴⁾	123 ⁽⁴⁾	106 ⁽⁴⁾	66	67	51	53	41	41	48
		500	178 ⁽⁴⁾	159 ⁽⁴⁾	134 ⁽⁴⁾	123 ⁽⁴⁾	106 ⁽⁴⁾	66	67	51	53	41	40	48
		600	178 ⁽⁴⁾	159 ⁽⁴⁾	134 ⁽⁴⁾	123 ⁽⁴⁾	106 ⁽⁴⁾	66	67	51	53	41	38	48
		700	178 ⁽⁴⁾	159 ⁽⁴⁾	134 ⁽⁴⁾	123 ⁽⁴⁾	106 ⁽⁴⁾	66	67	51	53	41	37	48
		800	178 ⁽⁴⁾	159 ⁽⁴⁾	134 ⁽⁴⁾	123 ⁽⁴⁾	106 ⁽⁴⁾	66	67	50	53	41	34	48
14	Forward	-20 to 800	178	159	134	123	106	66	67	51	53	41	44	48
	Reverse	-20 to 800	100	100	100	100	100	66	67	51	53	41	44	48
15	Forward or reverse	-20 to 120	760	876	730	840	746	484	490					
		150	760	848	730	840	746	484	490					
		200	704	704	704	704	704	484	490					
		250	560	560	560	560	560	484	490					
		300	416	416	416	416	416	416	416					
		375	200	200	200	200	200	200	200					
		400	150	150	150	150	150	150	150					
		450	50	50	50	50	50	50	50					

1. Based on valve body assembly material strengths only—actuator torque not considered.
 2. This trim not available in the 2- and 3-inch valve body sizes.
 3. For hot water or steam service, limit maximum temperature to 405°F.
 4. Reverse pressure drop is limited to 100 psi.

Product Bulletin

51.6:edisc (EMA)
August 2004

8510/8510B Valve

Table 8. Maximum Allowable Shutoff Pressure Drops⁽¹⁾ in Bar for Stainless Steel Valve Body Material

TABLE 4 OR 5 TRIM NUMBER	FLOW DIRECTION	TEMP. °C	MAX ALLOWABLE SHUTOFF ΔP (PER VALVE BODY SIZE, INCHES)												
			Type 8510B						Type 8510						
			2	3	4	6	8	10	12	14	16	18	20	24	
3, 4, NT3	Forward or reverse	-46 to 49	56.2	64.5	53.8	57.9	54.6	37.7	41.4	19.7	19.7	19.7	19.7	19.7	
		66	56.2	58.5	53.8	57.9	54.6	37.7	41.4	19.0	19.0	19.0	19.0	19.0	
		93	48.5	48.5	48.5	48.5	48.5	37.7	41.4	17.9	17.9	17.9	17.9	17.9	
		121	38.6	38.6	38.6	38.6	38.6	37.7	38.6	16.9	16.9	16.9	16.9	16.9	
		149	28.7	28.7	28.7	28.7	28.7	28.7	28.7	15.5	15.5	15.5	15.5	15.5	
		191	13.8	13.8	13.8	13.8	13.8	13.8	13.8	13.8	13.8	13.8	13.8	13.8	13.8
		204	10.3	10.3	10.3	10.3	10.3	10.3	10.3	10.3	10.3	10.3	10.3	10.3	10.3
		232 ⁽²⁾	3.4	3.4	3.4	3.4	3.4	3.4	3.4	3.4	3.4	3.4	3.4	3.4	
7	Forward	-46 to 232 ⁽²⁾	51.0	51.0	51.0	51.0	31.0	17.2	17.2	10.3	10.3	10.3	10.3	10.3	
	Reverse	-46 to 232 ⁽²⁾	6.9	6.9	6.9	6.9	6.9	6.9	6.9	6.9	6.9	6.9	6.9	6.9	
8	Forward	-46 to 232 ⁽²⁾	51.0	51.0	51.0	51.0	31.0	17.2	17.2	10.3	10.3	10.3	10.3	10.3	
	Reverse	-46 to 232 ⁽²⁾	6.9	6.9	6.9	6.9	6.9	6.9	6.9	6.9	6.9	6.9	6.9	6.9	
11x7.4 ⁽³⁾	Forward or reverse	-46 to 93	19.7 ⁽³⁾	21.9 ⁽³⁾	18.5 ⁽³⁾	17.0 ⁽³⁾	14.6 ⁽³⁾	9.1 ⁽³⁾	9.0 ⁽³⁾	5.2	7.4 ⁽³⁾	5.7	3.7	6.7	
		149	17.1 ⁽³⁾	21.9 ⁽³⁾	18.5 ⁽³⁾	17.0 ⁽³⁾	14.6 ⁽³⁾	9.1 ⁽³⁾	8.1 ⁽³⁾	4.6	7.4 ⁽³⁾	5.7	3.2	6.7	
		204	15.0 ⁽³⁾	21.9 ⁽³⁾	18.5 ⁽³⁾	17.0 ⁽³⁾	14.6 ⁽³⁾	9.1 ⁽³⁾	7.4 ⁽³⁾	4.1	7.4 ⁽³⁾	5.2	2.8	6.7	
		260	14.6 ⁽³⁾	21.9 ⁽³⁾	18.5 ⁽³⁾	17.0 ⁽³⁾	14.6 ⁽³⁾	9.1 ⁽³⁾	7.2 ⁽³⁾	3.9	7.4 ⁽³⁾	5.1	2.8	6.6	
		316	13.9 ⁽³⁾	21.9 ⁽³⁾	18.5 ⁽³⁾	17.0 ⁽³⁾	14.6 ⁽³⁾	9.1 ⁽³⁾	7.0 ⁽³⁾	3.8	7.4 ⁽³⁾	4.9	2.6	6.4	
		371	13.3 ⁽³⁾	21.9 ⁽³⁾	18.5 ⁽³⁾	16.8 ⁽³⁾	14.6 ⁽³⁾	9.1 ⁽³⁾	6.8	3.7	7.4 ⁽³⁾	4.8	2.6	6.3	
		427	12.6 ⁽³⁾	21.9 ⁽³⁾	18.5 ⁽³⁾	16.3 ⁽³⁾	14.6 ⁽³⁾	9.1 ⁽³⁾	6.6	3.4	7.4 ⁽³⁾	4.6	2.3	6.1	
		482	11.9 ⁽³⁾	21.9 ⁽³⁾	18.5 ⁽³⁾	15.8 ⁽³⁾	14.6 ⁽³⁾	9.1 ⁽³⁾	6.3	3.2	7.3 ⁽³⁾	4.3	2.2	5.9	
438	11.1 ⁽³⁾	21.9 ⁽³⁾	18.5 ⁽³⁾	15.2 ⁽³⁾	14.6 ⁽³⁾	9.1 ⁽³⁾	6.1	3.0	7.0 ⁽³⁾	4.1	2.1	5.7			
12	Forward or reverse	-46 to 149	19.7 ⁽³⁾	21.9 ⁽³⁾	18.5 ⁽³⁾	17.0 ⁽³⁾	14.6 ⁽³⁾	9.1 ⁽³⁾	9.0 ⁽³⁾	5.3	7.4 ⁽³⁾	5.7	3.8	6.7	
		204	18.2 ⁽³⁾	21.9 ⁽³⁾	18.5 ⁽³⁾	17.0 ⁽³⁾	14.6 ⁽³⁾	9.1 ⁽³⁾	8.5 ⁽³⁾	4.9	7.4 ⁽³⁾	5.7	3.5	6.7	
		260	17.3 ⁽³⁾	21.9 ⁽³⁾	18.5 ⁽³⁾	17.0 ⁽³⁾	14.6 ⁽³⁾	9.1 ⁽³⁾	8.2 ⁽³⁾	4.7	7.4 ⁽³⁾	5.7	3.3	6.7	
		316	16.8 ⁽³⁾	21.9 ⁽³⁾	18.5 ⁽³⁾	17.0 ⁽³⁾	14.6 ⁽³⁾	9.1 ⁽³⁾	8.1 ⁽³⁾	4.6	7.4 ⁽³⁾	5.7	3.2	6.7	
		371	15.9 ⁽³⁾	21.9 ⁽³⁾	18.5 ⁽³⁾	17.0 ⁽³⁾	14.6 ⁽³⁾	9.1 ⁽³⁾	7.7 ⁽³⁾	4.3	7.4 ⁽³⁾	5.4	3.0	6.7	
427	15.0 ⁽³⁾	21.9 ⁽³⁾	18.5 ⁽³⁾	17.0 ⁽³⁾	14.6 ⁽³⁾	9.1 ⁽³⁾	7.4 ⁽³⁾	4.1	7.4 ⁽³⁾	5.2	2.8	6.7			
13	Forward or reverse	-46 to 149	12.3 ⁽³⁾	11.0 ⁽³⁾	9.2 ⁽³⁾	8.5 ⁽³⁾	7.3 ⁽³⁾	4.6	4.6	3.5	3.7	2.8	3.0	3.3	
		204	12.3 ⁽³⁾	11.0 ⁽³⁾	9.2 ⁽³⁾	8.5 ⁽³⁾	7.3 ⁽³⁾	4.6	4.6	3.5	3.7	2.8	2.8	3.3	
		260	12.3 ⁽³⁾	11.0 ⁽³⁾	9.2 ⁽³⁾	8.5 ⁽³⁾	7.3 ⁽³⁾	4.6	4.6	3.5	3.7	2.8	2.8	3.3	
		316	12.3 ⁽³⁾	11.0 ⁽³⁾	9.2 ⁽³⁾	8.5 ⁽³⁾	7.3 ⁽³⁾	4.6	4.6	3.5	3.7	2.8	2.6	3.3	
		371	12.3 ⁽³⁾	11.0 ⁽³⁾	9.2 ⁽³⁾	8.5 ⁽³⁾	7.3 ⁽³⁾	4.6	4.6	3.5	3.7	2.8	2.6	3.3	
		427	12.3 ⁽³⁾	11.0 ⁽³⁾	9.2 ⁽³⁾	8.5 ⁽³⁾	7.3 ⁽³⁾	4.6	4.6	3.4	3.7	2.8	2.3	3.3	
		482	11.9 ⁽³⁾	11.0 ⁽³⁾	9.2 ⁽³⁾	8.5 ⁽³⁾	7.3 ⁽³⁾	4.6	4.6	3.2	3.7	2.8	2.2	3.3	
538	11.1 ⁽³⁾	11.0 ⁽³⁾	9.2 ⁽³⁾	8.5 ⁽³⁾	7.3 ⁽³⁾	4.6	4.6	3.0	3.7	2.8	2.1	3.3			
14	Forward	-46 to 371	12.3	11.0	9.2	8.5	7.3	4.6	4.6	3.5	3.7	2.8	3.0	3.3	
	Reverse	-46 to 371	6.9	6.9	6.9	6.9	6.9	6.9	6.9	6.9	6.9	6.9	6.9	6.9	

1. Based on valve body assembly material strengths only—actuator torque not considered.
 2. For hot water or steam service, limit maximum temperature to 207°C.
 3. Reverse pressure drop is limited to 6.9 bar.

8510/8510B Valve

Table 9. Maximum Allowable Shutoff Pressure Drops⁽¹⁾ in Psi for Stainless Steel Valve Body Material

TABLE 4 OR 5 TRIM NUMBER	FLOW DIRECTION	TEMP. °F	MAX ALLOWABLE SHUTOFF ΔP (PER VALVE BODY SIZE, INCHES)											
			Type 8510B						Type 8510					
			2	3	4	6	8	10	12	14	16	18	20	24
3, 4, NT3	Forward or reverse	-50 to 120	816	935	780	840	792	547	600	275	275	275	275	275
		150	816	848	780	840	792	547	600	257	257	257	257	257
		200	704	704	704	704	704	547	600	240	240	240	240	240
		250	560	560	560	560	560	547	560	227	227	227	227	227
		300	416	416	416	416	416	416	416	215	215	215	215	215
		375	200	200	200	200	200	200	200	200	200	200	200	200
		400	150	150	150	150	150	150	150	150	150	150	150	150
		450 ⁽²⁾	50	50	50	50	50	50	50	50	50	50	50	
7	Forward	-50 to 450 ⁽²⁾	740	740	740	740	450	250	250	150	150	150	150	150
	Reverse	-50 to 450 ⁽²⁾	100	100	100	100	100	100	100	100	100	100	100	100
8	Forward	-50 to 450 ⁽²⁾	740	740	740	740	450	250	250	150	150	150	150	150
	Reverse	-50 to 450 ⁽²⁾	100	100	100	100	100	100	100	100	100	100	100	100
11	Forward or reverse	-50 to 200	285 ⁽³⁾	318 ⁽³⁾	268 ⁽³⁾	246 ⁽³⁾	212 ⁽³⁾	132 ⁽³⁾	130 ⁽³⁾	76	107 ⁽³⁾	82	54	97
		300	248 ⁽³⁾	318 ⁽³⁾	268 ⁽³⁾	246 ⁽³⁾	212 ⁽³⁾	132 ⁽³⁾	118 ⁽³⁾	67	107 ⁽³⁾	82	54	97
		400	218 ⁽³⁾	318 ⁽³⁾	268 ⁽³⁾	246 ⁽³⁾	212 ⁽³⁾	132 ⁽³⁾	107 ⁽³⁾	59	107 ⁽³⁾	75	41	97
		500	212 ⁽³⁾	318 ⁽³⁾	268 ⁽³⁾	246 ⁽³⁾	212 ⁽³⁾	132 ⁽³⁾	105 ⁽³⁾	57	107 ⁽³⁾	74	40	96
		600	201 ⁽³⁾	318 ⁽³⁾	268 ⁽³⁾	246 ⁽³⁾	212 ⁽³⁾	132 ⁽³⁾	102 ⁽³⁾	55	107 ⁽³⁾	71	38	93
		700	193 ⁽³⁾	318 ⁽³⁾	268 ⁽³⁾	243 ⁽³⁾	212 ⁽³⁾	132 ⁽³⁾	99	53	107 ⁽³⁾	69	37	91
		800	183 ⁽³⁾	318 ⁽³⁾	268 ⁽³⁾	236 ⁽³⁾	212 ⁽³⁾	132 ⁽³⁾	95	50	107 ⁽³⁾	66	34	88
		900	172 ⁽³⁾	318 ⁽³⁾	268 ⁽³⁾	229 ⁽³⁾	212 ⁽³⁾	132 ⁽³⁾	91	47	106 ⁽³⁾	63	32	85
		1000	161 ⁽³⁾	318 ⁽³⁾	268 ⁽³⁾	221 ⁽³⁾	212 ⁽³⁾	132 ⁽³⁾	88	44	102 ⁽³⁾	60	30	82
12	Forward or reverse	-50 to 300	285 ⁽³⁾	318 ⁽³⁾	268 ⁽³⁾	246 ⁽³⁾	212 ⁽³⁾	132 ⁽³⁾	131 ⁽³⁾	77	107 ⁽³⁾	82	55	97
		400	264 ⁽³⁾	318 ⁽³⁾	268 ⁽³⁾	246 ⁽³⁾	212 ⁽³⁾	132 ⁽³⁾	124 ⁽³⁾	71	107 ⁽³⁾	82	51	97
		500	251 ⁽³⁾	318 ⁽³⁾	268 ⁽³⁾	246 ⁽³⁾	212 ⁽³⁾	132 ⁽³⁾	119 ⁽³⁾	68	107 ⁽³⁾	82	48	97
		600	244 ⁽³⁾	318 ⁽³⁾	268 ⁽³⁾	246 ⁽³⁾	212 ⁽³⁾	132 ⁽³⁾	117 ⁽³⁾	66	107 ⁽³⁾	82	47	97
		700	231 ⁽³⁾	318 ⁽³⁾	268 ⁽³⁾	246 ⁽³⁾	212 ⁽³⁾	132 ⁽³⁾	112 ⁽³⁾	62	107 ⁽³⁾	79	44	97
		800	218 ⁽³⁾	318 ⁽³⁾	268 ⁽³⁾	246 ⁽³⁾	212 ⁽³⁾	132 ⁽³⁾	107 ⁽³⁾	59	107 ⁽³⁾	75	41	97
13	Forward or reverse	-50 to 300	178 ⁽³⁾	159 ⁽³⁾	134 ⁽³⁾	123 ⁽³⁾	106 ⁽³⁾	66	67	51	53	41	44	48
		400	178 ⁽³⁾	159 ⁽³⁾	134 ⁽³⁾	123 ⁽³⁾	106 ⁽³⁾	66	67	51	53	41	41	48
		500	178 ⁽³⁾	159 ⁽³⁾	134 ⁽³⁾	123 ⁽³⁾	106 ⁽³⁾	66	67	51	53	41	40	48
		600	178 ⁽³⁾	159 ⁽³⁾	134 ⁽³⁾	123 ⁽³⁾	106 ⁽³⁾	66	67	51	53	41	38	48
		700	178 ⁽³⁾	159 ⁽³⁾	134 ⁽³⁾	123 ⁽³⁾	106 ⁽³⁾	66	67	51	53	41	37	48
		800	178 ⁽³⁾	159 ⁽³⁾	134 ⁽³⁾	123 ⁽³⁾	106 ⁽³⁾	66	67	50	53	41	34	48
		900	172 ⁽³⁾	159 ⁽³⁾	134 ⁽³⁾	123 ⁽³⁾	106 ⁽³⁾	66	67	47	53	41	32	48
		1000	161 ⁽³⁾	159 ⁽³⁾	134 ⁽³⁾	123 ⁽³⁾	106 ⁽³⁾	66	67	44	53	41	30	48
14	Forward	-50 to 800	178	159	134	123	106	66	67	51	53	41	44	48
	Reverse	-50 to 800	100	100	100	100	100	66	67	51	53	41	44	48

1. Based on valve body assembly material strengths only—actuator torque not considered.
 2. For hot water or steam service, limit maximum temperature to 405°F.
 3. Reverse pressure drop is limited to 100 psi.

Product Bulletin

51.6:edisc (EMA)
August 2004

8510/8510B Valve

Table 10. Maximum Allowable Forward and Reverse Shutoff Pressure Drops⁽¹⁾ for Alloy Valve Body Materials

ALLOY VALVE BODY MATERIAL	TABLE 5 TRIM NUMBER	TEMPERATURE		MAX ALLOWABLE SHUTOFF ΔP (PER VALVE BODY SIZE, INCHES)															
				Type 8510B															
		°C	°F	2		3		4		6		8		10		12			
				Bar	Psi	Bar	Psi	Bar	Psi	Bar	Psi	Bar	Psi	Bar	Psi	Bar	Psi		
Monel 411 M35-1	15	-46 to 49	-50 to 120	52.4	760	60.4	876	50.3	730	57.9	840	51.4	746	33.4	484	33.8	490		
		93	200	40.3	584	45.8	664	38.9	564	44.1	639	39.6	575	27.2	395	27.5	399		
		149	300	25.2	365	27.5	399	24.5	356	26.8	388	24.8	360	19.6	284	19.7	285		
		191	375	13.8	200	13.8	200	13.8	200	13.8	200	13.8	200	13.8	200	13.8	200		
		204	400	10.3	150	10.3	150	10.3	150	10.3	150	10.3	150	10.3	150	10.3	150		
		232	450	3.4	50	3.4	50	3.4	50	3.4	50	3.4	50	3.4	50	3.4	50		
Alloy 20 CN-7M	17	-46 to 49	-50 to 120	18.6	270	33.2	482	34.3	497	24.0	348	32.1	465	16.8	244	12.7	184		
		66	150	18.1	262	31.0	449	31.9	462	22.8	331	29.9	434	16.5	239	—	—		
		93	200	17.1	248	27.1	393	27.9	404	20.8	302	26.3	382	15.9	230	—	—		
		149	300	15.2	221	19.5	283	19.8	287	16.8	244	19.2	278	14.7	213	—	—		

1. Based on valve body assembly material strengths only—actuator torque not considered.

Table 11. Material Temperature Capabilities

VALVE BODY MATERIAL	TABLE 4 OR 5 TRIM NUMBER	PACKING	MATERIAL TEMPERATURE CAPABILITY ⁽¹⁾	
			°C	°F
Steel	1, 2, 3, 4, 5, 6, 7, 8	All	-29 to 232 ⁽¹⁾	-20 to 450 ⁽¹⁾
	9, 10, 11, 12, 13, 14	PTFE V-ring or PTFE composition	-29 to 232	-20 to 450
		Graphite ribbon	-29 to 427	-20 to 800
	15	All	-29 to 232	-20 to 450
	NT3	PTFE V-ring	-29 to 232 ⁽¹⁾	-20 to 450 ⁽¹⁾
316 stainless steel	3, 4, 8	PTFE V-ring	-40 to 232 ⁽¹⁾	-40 to 450 ⁽¹⁾
		PTFE composition or graphite ribbon	-46 to 232 ⁽¹⁾	-50 to 450 ⁽¹⁾
	7	PTFE V-ring	-40 to 232 ⁽¹⁾	-40 to 450 ⁽¹⁾
		PTFE composition	-46 to 232 ⁽¹⁾	-50 to 450 ⁽¹⁾
		Graphite ribbon	-46 to 232 ⁽¹⁾	-50 to 450 ⁽¹⁾
	11, 13	PTFE V-ring	-40 to 232	-40 to 450 ⁽¹⁾
PTFE composition Graphite ribbon		-46 to 260 -46 to 538	-50 to 500 -50 to 1000	
12, 14	PTFE V-ring	-40 to 232	-40 to 450	
	PTFE composition Graphite ribbon	-46 to 260 -46 to 427	-50 to 500 -50 to 800	
NT3	PTFE V-ring	-40 to 232 ⁽¹⁾	-40 to 450 ⁽¹⁾	
Monel	15	PTFE V-ring	-40 to 232	-40 to 450
		PTFE composition or graphite ribbon	-46 to 232	-50 to 450
Alloy 20	17	PTFE V-ring	-40 to 149	-40 to 300
		PTFE composition or graphite ribbon	-46 to 149	-50 to 300

1. For hot water or steam service, limit maximum temperature to 207°C (405°F)

Installation

As indicated in this bulletin, Monel valve bodies are not ASME B16.34 or ASME code-approved materials. Valve bodies constructed of Monel will mate with ANSI flanges, but are not included in ANSI pressure-temperature ratings and must not be installed in systems requiring conformance to ANSI standards.

A Type 8510 and Type 8510B valve may be installed in any position.

Dimensions are shown in figure 9.

Ordering Information

Note: Fisher does not assume responsibility for the selection, use, or maintenance of any product. Responsibility for proper selection, use, and maintenance of any Fisher product remains solely with the purchaser and end-user.

When ordering, specify:

Application

1. Type of application
 - a. Throttling or on/off
 - b. Reducing or relief
2. Controlled fluid

3. Specific gravity of controlled fluid
4. Fluid temperature
5. Range of flowing inlet pressures
6. Pressure drops
 - a. Range of flowing pressure drops
 - b. Maximum at shutoff
7. Flow rates
 - a. Minimum controlled flow
 - b. Normal flow
 - c. Maximum flow
8. Maximum permissible noise level, if critical
9. Line size and schedule

Valve Information

Refer to the Specifications table. Review the information under each specification and in the referenced tables. Indicate the choice wherever there is a selection to be made.

Actuator and Accessory Information

Specify the desired actuator type and size from the separate actuator bulletin. Also refer to the separate actuator and accessory bulletins for additional ordering information.

Product Bulletin

51.6:edisc (EMA)
August 2004

8510/8510B Valve

Table 12. Dimensions for Type 8510 and 8510B

VALVE SIZE, INCHES	A	B	D	F	G	K	R	S (SHAFT DIA)	T	U	W	APPROXIMATE WEIGHT ⁽¹⁾
	mm											kg
2	45	59	187	141	138	102	103	12.7	117	---	1/2-13	4.3
3	48	78	187	168	155	119	127	15.9	117	---	1/2-13	5.9
4	56	102	214	197	198	162	159	19.1	152	32	1/2-13	9.1
6	57	141	214	251	238	202	217	25.4	152	32	1/2-13	19
8	64	191	208	317	289	244	272	31.8	235	46	5/8-11	31
10	71	241	208	378	289	257	325	31.8	235	46	5/8-11	46
12	83	286	208	438	348	297	384	38.1	235	46	5/8-11	72
14	92	329	208	416	362	311	416	38.1	235	46	5/8-11	88
16	102	376	356	473	409	359	473	44.5	273	51	3/4-10	102
18	114	427	356	536	397	346	536	44.5	273	51	3/4-10	136
20	127	470	356	589	464	406	589	50.8	273	51	3/4-10	204
24	154	564	356	699	522	465	699	63.5	337	76	7/8-9	277
	Inches											Pounds
2	1.78	2.31	7.38	5.56	5.44	4.00	4.06	0.5	4.62	---	1/2-13	9.5
3	1.88	3.06	7.38	6.62	6.12	4.69	5.00	0.625	4.62	---	1/2-13	13
4	2.19	4.00	8.44	7.75	7.81	6.38	6.25	0.75	6.00	1.25	1/2-13	20
6	2.25	5.56	8.44	9.88	9.38	7.94	8.53	1	6.00	1.25	1/2-13	41
8	2.5	7.50	8.19	12.50	11.38	9.62	10.69	1.25	9.25	1.81	5/8-11	69
10	2.81	9.50	8.19	14.88	11.38	10.12	12.81	1.25	9.25	1.81	5/8-11	102
12	3.25	11.25	8.19	17.25	13.69	11.69	15.12	1.5	9.25	1.81	5/8-11	158
14	3.62	12.94	8.19	16.38	14.25	12.25	16.38	1.5	9.25	1.81	5/8-11	194
16	4.00	14.81	14.00	18.62	16.12	14.12	18.62	1.75	10.75	2.00	3/4-10	225
18	4.50	16.81	14.00	21.12	15.62	13.62	21.12	1.75	10.75	2.00	3/4-10	300
20	5.00	18.50	14.00	23.19	18.25	16.00	23.19	2	10.75	2.00	3/4-10	450
24	6.06	22.19	14.00	27.50	20.56	18.31	27.50	2.5	13.25	3.00	7/8-9	610

1. Valve assembly only.

Table 13. Dimensions for Type 8510 and 8510B

DIN VALVE BODY SIZE	A FACE-TO-FACE		RAISED FACE			
	mm	mm	mm			
			PN 10	PN 16	PN 25	PN 40-100
DN 50	43	102	102	102	102	102
DN 80	49	138	138	138	138	138
DN 100	56	158	158	158	162	162
DN 150	70	212	212	212	218	218
DN 200	71	268	268	268	278	285
DN 250	76	320	320	320	335	345
DN 300	83	370	378	378	395	410

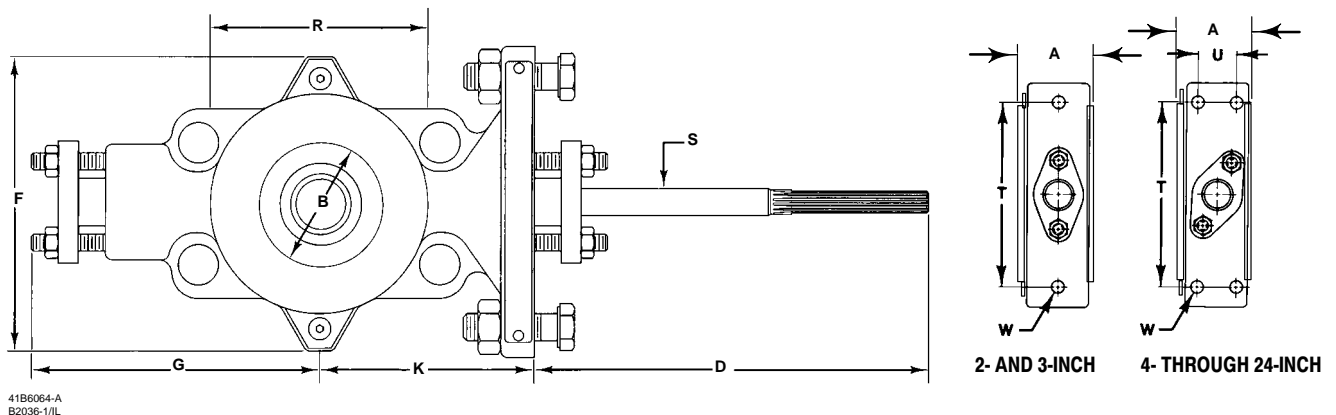

Figure 9. Dimensions for Type 8510 and 8510B (also see tables 12 and 13)

8510/8510B Valve

Table 14. Dimensions for Type 8510B with Alternate Double D Shaft

VALVE SIZE, INCHES	A	B	D	F	G	K	R	S (SHAFT DIA)	T	U	W	APPROXIMATE WEIGHT ⁽¹⁾
	mm											kg
2	45	59	—	141	138	102	103	—	117	—	1/2-13	4.3
3	48	78	83	168	155	119	127	12.7	117	—	1/2-13	5.9
4	54	102	83	197	198	162	159	15.7	152	32	1/2-13	9.1
6	57	141	83	251	238	202	217	19.0	152	32	1/2-13	19
8	64	191	83	317	289	244	272	25.4	235	46	5/8-11	31
10	71	241	89	378	289	257	325	31.8	235	46	5/8-11	46
12	83	286	89	438	348	297	384	38.1	235	46	5/8-11	72
	Inches											Pounds
2	1.78	2.31	—	5.56	5.44	4.00	4.06	—	4.62	—	1/2-13	9.5
3	1.88	3.06	3.25	6.62	6.12	4.69	5.00	0.5	4.62	—	1/2-13	13
4	2.12	4.00	3.25	7.75	7.81	6.38	6.25	0.625	6.00	1.25	1/2-13	20
6	2.25	5.56	3.25	9.88	9.38	7.94	8.53	0.75	6.00	1.25	1/2-13	41
8	2.50	7.50	3.25	12.50	11.38	9.62	10.69	1	9.25	1.81	5/8-11	69
10	2.81	9.50	3.50	14.88	11.38	10.12	12.81	1.25	9.25	1.81	5/8-11	102
12	3.19	11.25	3.50	17.25	13.69	11.69	15.12	1.5	9.25	1.81	5/8-11	158

1. Valve assembly only.

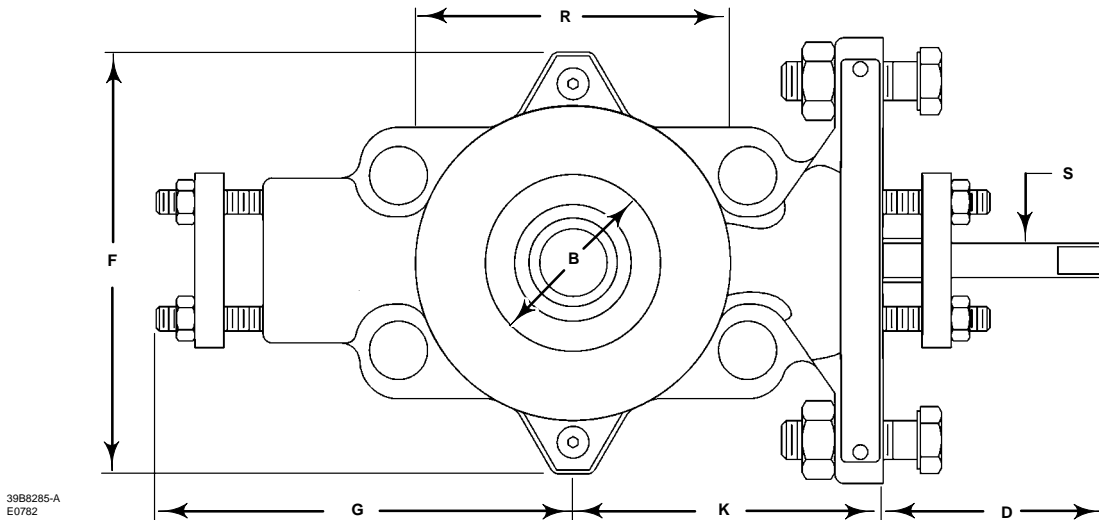

Figure 10. Dimensions for Type 8510B with Alternate Double D Shaft (also see table 14)

ēdisc, ENVIRO-SEAL and Fisher are marks owned by Fisher Controls International LLC, a member of the Emerson Process Management business division of Emerson Electric Co. The Emerson logo is a trademark and service mark of Emerson Electric Co. All other marks are the property of their respective owners. This product may be covered under one or more of the following patents: 5,129,635; 5,230,498 and 5,299,812 or under pending patents.

The contents of this publication are presented for informational purposes only, and while every effort has been made to ensure their accuracy, they are not to be construed as warranties or guarantees, express or implied, regarding the products or services described herein or their use or applicability. We reserve the right to modify or improve the designs or specifications of such products at any time without notice.

Fisher does not assume responsibility for the selection, use or maintenance of any product. Responsibility for proper selection, use and maintenance of any Fisher product remains solely with the purchaser and end-user.

Emerson Process Management

Fisher

Marshalltown, Iowa 50158 USA
Cernay 68700 France
Sao Paulo 05424 Brazil
Singapore 128461

www.Fisher.com

