

Fisher™ Dirty Service Anti-Cavitation Trim (DST)

Fisher Dirty Service Trim (DST) is a multi-stage, anti-cavitation control valve trim for use in services where the fluid may have entrained particulate that could plug the passages, or cause erosion damage to conventional anti-cavitation trims. DST is frequently used in high pressure drop applications up to 4200 psid in the chemical, refining, oil and gas production, and power industries.

Features

- **Cavitation Control**—2-, 3-, 4-, 5-, or 6-stage DST used in a valve properly selected for flow conditions can eliminate cavitation and associated damage and noise.
- **Versatility**—Available in globe and angle valves, flow down (figure 2) or flow up (figure 3), from NPS 1 to 16 having weld-end or flanged-end connections. Can be used in easy-e™, EH, EHA, EW, HP, and HPA valves.
- **Long Trim Life**—This trim concept uses a combined axial and radial flow that features large, open flow paths and decreased clearance flow erosion.
- **Flexibility**—In many cases DST can be retrofitted to replace Cav III trims that are currently in service. DST can pass 1/4 to 3/4-inch particles without plugging.
- **Easy Maintenance**—In-line trim removal allows inspection of parts without taking the valve body out of the pipeline.
- **Sour Service Capability**—Materials are available for applications handling sour fluids. Please contact your [Emerson sales office](#) for additional information.
- **Trim Materials**—Typical trim materials include S17400 cages, S44004 valve plug and seat, S31600/ENC/CoCr-A cages with S31600/CoCr-A valve plug and seat, or S32550/ENC/CoCr-A cages with S32550/CoCr-A valve plug and seat, or R31233 cages with R31233 valve plug and seat. Other materials are available to satisfy application requirements.
- **Shutoff**—DST also features a protected seat design where the shutoff function of the valve is separate from the throttling areas of the trim.
- **High-Temperature Class V Shutoff**—Use of the metal C-seal permits Class V shutoff above 316°C (600°F).



W6787-1

FISHER DIRTY SERVICE TRIM

Specifications

Available Valves

easy-e, EH, EHA, EU, EW, HP, and HPA.
See table 3

End Connection Styles

Refer to appropriate valve bulletin

Valve Body Dimensions and Weights

Valve type, pressure class, and number of stages will result in changes to these values. Please consult your [Emerson sales office](#) for more information on finished dimensions and weights

Shutoff Classifications

Class V per ANSI/FCS 70-2 and IEC 60534-4

Maximum Inlet Pressures and Temperatures⁽¹⁾

Consistent with applicable CL150, CL300, CL600, CL900, CL1500, and CL2500 pressure/temperature ratings according to ASME B16.34 ratings unless limited by individual temperature and pressure limits shown in tables 1 and 2

Maximum Pressure Drop⁽¹⁾

See table 1

Construction Materials

Trim Parts: ■ S17400 cages, S44004 valve plug and seat or S31600/ENC/CoCr-A cages with S31600/CoCr-A valve plug and seat

■ S32550/ENC/CoCr-A cages, S32550/CoCr-A valve plug and seat ■ R31233 cages, R31233 valve plug and seat. Trim can be made from several other bar stock alloys. Consult your Emerson sales office for your specific application

Temperature Capabilities

Valve Body/Trim Combinations: See table 2
All Other Parts: Consult your Emerson sales office

Flow Coefficients

See table 3

Flow Characteristic

Linear

Flow Direction

Flow down (typical) or Flow up (available)

Valve Cavitation Coefficient

$K_c = 1.0$ for all valves when trim is used within applicable pressure drop limits.

Maximum Valve Plug Travel

Typical plug travels are 0.75 inch through 2 inch. Contact your Emerson sales office for your specific application

Minimum Seating Force

Use Class V seat load requirements

1. The pressure/temperature limits in this bulletin and any applicable standard or code limitation for valve should not be exceeded.

Contents

Features 1
 Specifications 2
 Principle of Operation 3
 Availability 3
 Trim Selection Guidelines 4
 Characteristics 4
 Valve Sizing Guidelines 4

Ordering Information 5
 Tables
 Available Pressure Drop Limits 3
 Trim Combinations for DST 4
 DST Availability 5
 Typical Applications 8

Table 1. Allowable Pressure Drop Limits

PRESSURE DROP LIMITS				
Number of Stages	Flowing Pressure Drop Limit (bar)	Flowing Pressure Drop Limit (psi)	FI	Kc
2	52	750	0.95	1.0
3	103	1500	0.97	1.0
4	207	3000	0.99	1.0
5	241	3500	0.99	1.0
6	289	4200	0.99	1.0

Figure 1. Staged Pressure Drop Patterns

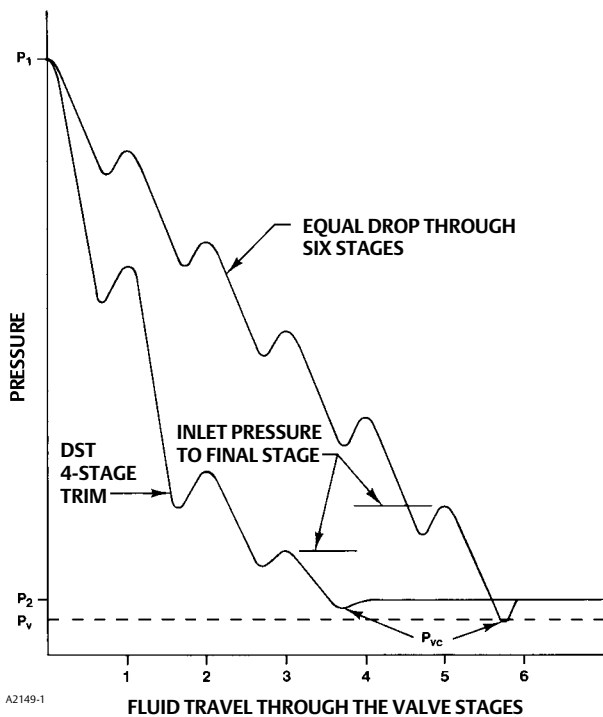

are not worn away by throttling control action, (valve must always be throttled above the min C_v) resulting in extended shutoff capabilities.

In conventional staged-trim designs, cavitation usually does not exist until the final stage. Figure 1 illustrates why this happens. As shown, the greater the pressure drop through the final stage, the lower the vena contracta pressure (P_{vc}). If P_{vc} is less than or equal to P_v , and P_2 is greater than P_v , then cavitation will result.

The DST valve avoids this by means of its unique expanding flow area design. Each of the stages has a successively larger flow area. The result is a very efficient operation because more than 90 percent of the overall pressure drop is taken in the stages prior to the final stage where there is little danger of bubble formation. Consequently, a relatively low inlet pressure to the final stage is achieved. Figure 1 also compares the pressure drop pattern through the four stages in the expanding area DST design with a pattern representing a six-stage trim design with each stage taking an equal portion of the total pressure drop. As can be seen, the inlet pressure to the last stage of DST trim is always less than the inlet pressure to the sixth stage of an equal-drop cage. Therefore the P_{vc} of the DST cage remains higher than the P_{vc} of an equal-drop cage. If the pressure drops were all equivalent to that of the last stage in DST trim, 11 stages would be required in the equal-drop trim.

Principle of Operation

DST provides cavitation control for applications with entrained particulate that could potentially plug the inlet passages or cause severe erosion damage to conventional anti-cavitation trim. The DST design uses a combined axial and radial flow path that features large openings allowing particulate up to 3/4 inches in diameter to pass through the valve.

Due to the need for tight shutoff, the multi-stage design incorporates a protected seating surface that separates the shutoff and the throttling locations. All significant pressure drops are taken downstream of the seating surface. As a result, the seating surfaces

Availability

DST trim is available in numerous body designs and pressure classes. Table 1 shows the pressure drop limits for each design relative to the number of stages used.

Table 3 shows the different valve constructions that DST can be used in. It also shows typical min and max C_v values each valve can achieve. Any deviation from the sizes listed in table 3, or temperatures in table 2, will result in different C_v limitations. Please contact your [Emerson sales office](#) for any requests that do not fall within these ranges.

Table 2. Trim Combinations for Fisher DST⁽¹⁾

TRIM DESIGNATION	VALVE BODY MATERIAL	VALVE PLUG	CAGE	SEAT RING	MAXIMUM TEMPERATURE LIMIT	
					°C	°F
A	WCC	S44004	S17400	S17400 or S44004	316	600
B	WCC	S31600/CoCr-A	S31600/CoCr-A/ENC	S31600/CoCr-A/ENC	204	400
	SST				316	600
C	WCC	S32550/CoCr-A	S32550/CoCr-A/ENC	S32550/CoCr-A/ENC	316	600
	SST				204	400
581 ⁽²⁾	WCC	R31233	R31233	R31233	316	600
	LCC					
	CF8M					

1. Contact your [Emerson sales office](#) for higher temperature capabilities.
2. Reference Fisher ET, EAT, and ETR Sliding-Stem Control Valves Bulletin ([D100022X012](#)) for other material temperature limiting parts.

Trim Selection Guidelines

The standard trim materials are listed below, and in table 2. Other materials such as superaustenitic SST, S34700, Solid CoCr-A, N08800, and tungsten carbide trim are available upon request. Contact your Emerson sales office for more information.

- **Trim A:** Trim A is the typical trim used with carbon steel and alloy steel valve bodies. It can generally be used in severe service applications up to 316°C (600°F). Higher temperature can be achieved with alternate trim parts. Contact your Emerson sales office for higher temperature requirements. Typical applications for Trim A include boiler feedwater, water, non-sour hydrocarbons, and other non-sour liquids.
- **Trim B:** Trim B is the typical trim used with stainless steel valve bodies. It can generally be used in severe service applications up to 316°C (600°F). Higher temperatures can be achieved with alternate trim parts. Contact your Emerson sales office for higher temperature requirements. Typical applications for Trim B include produced water, water, sour hydrocarbons, and other sour liquids. Not for use with boiler feedwater.
- **Trim C:** Trim C can commonly be seen in carbon steel and Duplex SST valve bodies. This trim is most commonly used in sea water applications, produced water, and other offshore crude oil applications.

- **Trim 581:** Trim 581 can be used with carbon steel or stainless steel valve bodies. It can generally be used in severe service applications up to 316°C (600°F). Typical applications for Trim 581 include boiler feedwater, water, sour and non-sour hydrocarbons and other liquids.

Please contact your Emerson sales office for more information on DST trim.

Characteristics

The DST trim is designed to have a linear flow characteristic. It is also designed to have no significant flow for the first 10-15% travel. Special characterizations may be possible, including special low minimum C_v designs. Contact your Emerson sales office for assistance.

Valve Sizing Guidelines

Sizing procedures from Catalog 12 or Fisher Specification Manager can be used to size DST control valves. Noise calculations are best performed by using Fisher Specification Manager. The multi-stage configuration of the DST design reduces valve trim noise significantly. Select CAV III 2-Stage as the valve type in Fisher Specification Manager to perform the noise prediction calculation.

Ordering Information

When ordering, specify:

Application Information

1. Process Liquid: State particle size and type of entrained impurities, if any.
2. Specific gravity of liquid
3. Temperature and vapor pressure of liquid
4. Critical pressure

5. Range of flowing inlet pressures
6. Pressure drops
 - a. Range of flowing pressure drops
 - b. Maximum at shutoff
7. Flow rates
 - a. Minimum controlled flow
 - b. Normal flow
 - c. Maximum flow
8. Required C_v
9. Line size and schedule

Table 3. Fisher DST Flow Down Availability⁽⁴⁾

VALVE DESIGN	PRESSURE RATING	VALVE SIZE	PORT SIZE	TRAVEL	UNBALANCED AREA	MINIMUM AND MAXIMUM FLOW COEFFICIENTS, C_v ⁽³⁾							
						2-Stage		3-Stage		4-Stage		6-Stage	
						NPS	inch	inch	inch ²	Min	Max	Min	Max
easy-e Globe	CL600	1 ⁽⁵⁾	0.875	0.63	0.610	(1)		0.15	4.4	NA ⁽²⁾		NA ⁽²⁾	
		1.5 ⁽⁵⁾	1.125	0.75	0.800	(1)		0.22	8.9	NA ⁽²⁾		NA ⁽²⁾	
		2	1.75	0.75	0.029	0.3	23.1	0.22	18.5	NA ⁽²⁾		NA ⁽²⁾	
		2.5	2.188	0.75	0.061	0.5	30.5	0.4	23.4	NA ⁽²⁾		NA ⁽²⁾	
		3	2.50	0.75	0.041	0.8	46	0.8	36	NA ⁽²⁾		NA ⁽²⁾	
		4	3.438	1.25	0.118	1.7	81	1.5	64	NA ⁽²⁾		NA ⁽²⁾	
		6	4.375	1.50	0.154	2.8	174	2.8	128	NA ⁽²⁾		NA ⁽²⁾	
easy-e Angle	CL600	2 ⁽⁵⁾	1.125	0.75	0.800	(1)		0.22	8.9	NA ⁽²⁾		NA ⁽²⁾	
		3	2.188	0.75	0.061	0.5	30.5	0.4	23.4	NA ⁽²⁾		NA ⁽²⁾	
		4	2.50	0.75	0.041	0.8	46	0.8	36	NA ⁽²⁾		NA ⁽²⁾	
		6	3.438	1.25	0.118	1.7	81	1.5	64	NA ⁽²⁾		NA ⁽²⁾	
EH	CL1500	2	1.50	0.75	0.051	NA ⁽²⁾		(1)		0.3	7.5	(1)	
		3	1.875	1.00	0.031	NA ⁽²⁾		(1)		0.58	23	(1)	
		4	2.875	1.50	0.047	NA ⁽²⁾		1.4	54	1	44	(1)	
		6	3.625	1.75	0.118	NA ⁽²⁾		1.2	106	1	88.5	(1)	
		8	5.375	1.50	0.142	NA ⁽²⁾		4	147	3	115	(1)	
		10	5.375	1.50	0.142	NA ⁽²⁾		4	147	3	115	(1)	
		12	8.00	2.00	0.350	NA ⁽²⁾		(1)		10	298	(1)	
	14	8.00	2.00	0.350	NA ⁽²⁾		(1)		10	298	(1)		
	CL2500	3 ⁽⁵⁾	1.50	0.75	0.780	NA ⁽²⁾		NA ⁽²⁾		(1)		0.4	9.4
		4 ⁽⁵⁾	1.875	0.75	1.534	NA ⁽²⁾		NA ⁽²⁾		0.5	16	0.5	13.7
EHA	CL1500	4	1.875	1.00	0.031	NA ⁽²⁾		(1)		0.45	19.2	(1)	
		6	2.875	1.50	0.047	NA ⁽²⁾		1.4	54	1	44	(1)	
		8	3.625	1.75	0.118	NA ⁽²⁾		1.2	105	1	88.5	(1)	
	CL2500	4 ⁽⁶⁾	3.625	1.75	0.118	NA ⁽²⁾		NA ⁽²⁾		1	86	(1)	
		6 ⁽⁶⁾	2.875	1.50	0.047	NA ⁽²⁾		NA ⁽²⁾		1	46	1	28
EU	CL600	12	8.00	1.50	0.350	10	382	10	292	NA ⁽²⁾		NA ⁽²⁾	
		16	11.00	4.00	0.490	(1)		10	617	NA ⁽²⁾		NA ⁽²⁾	
EW	CL600	4X2	1.75	0.75	0.029	(1)		0.22	18.5	NA ⁽²⁾		NA ⁽²⁾	
		6X4	3.438	1.25	0.118	1.7	81	1.5	64	NA ⁽²⁾		NA ⁽²⁾	
		8X6	4.375	1.75	0.154	2.8	187	2.8	150	NA ⁽²⁾		NA ⁽²⁾	
		12X8	5.375	2.00	0.142	5.5	253	5	185	NA ⁽²⁾		NA ⁽²⁾	
HP	CL1500	3	1.875	1.00	0.031	NA ⁽²⁾		0.65	24.8	0.45	19.4	(1)	
		4	2.875	1.00	0.047	NA ⁽²⁾		1	39.5	1	34.6	(1)	
		6	3.625	1.50	0.118	NA ⁽²⁾		1.2	89.3	1	71	(1)	

-continued-

Table 3. Fisher DST Flow Down Availability⁽⁴⁾ (Cont.)

HP & HPA	CL1500	1 ⁽⁵⁾	0.875	0.63	0.589	NA ⁽²⁾	⁽¹⁾		0.09	3.2	⁽¹⁾	
		2 ⁽⁵⁾	1.25	0.75	0.785	NA ⁽²⁾	0.2	8.3	0.28	7.1	⁽¹⁾	
	CL2500	1 ⁽⁵⁾	0.875	0.63	0.589	NA ⁽²⁾	NA ⁽²⁾		⁽¹⁾		⁽¹⁾	
		2 ⁽⁵⁾	1.00	0.75	0.785	NA ⁽²⁾	NA ⁽²⁾		⁽¹⁾		0.3	4.3

1. Consult your Emerson sales office.
2. Construction not available.
3. 5-stage DST is available upon request.
4. For flow up constructions consult your [Emerson sales office](#).
5. Unbalanced constructions.
6. These valves are from block forged angle valve bodies. Cast valve bodies are available and may change these values.

Figure 2. 4-Stage Fisher DST Flow Down Trim

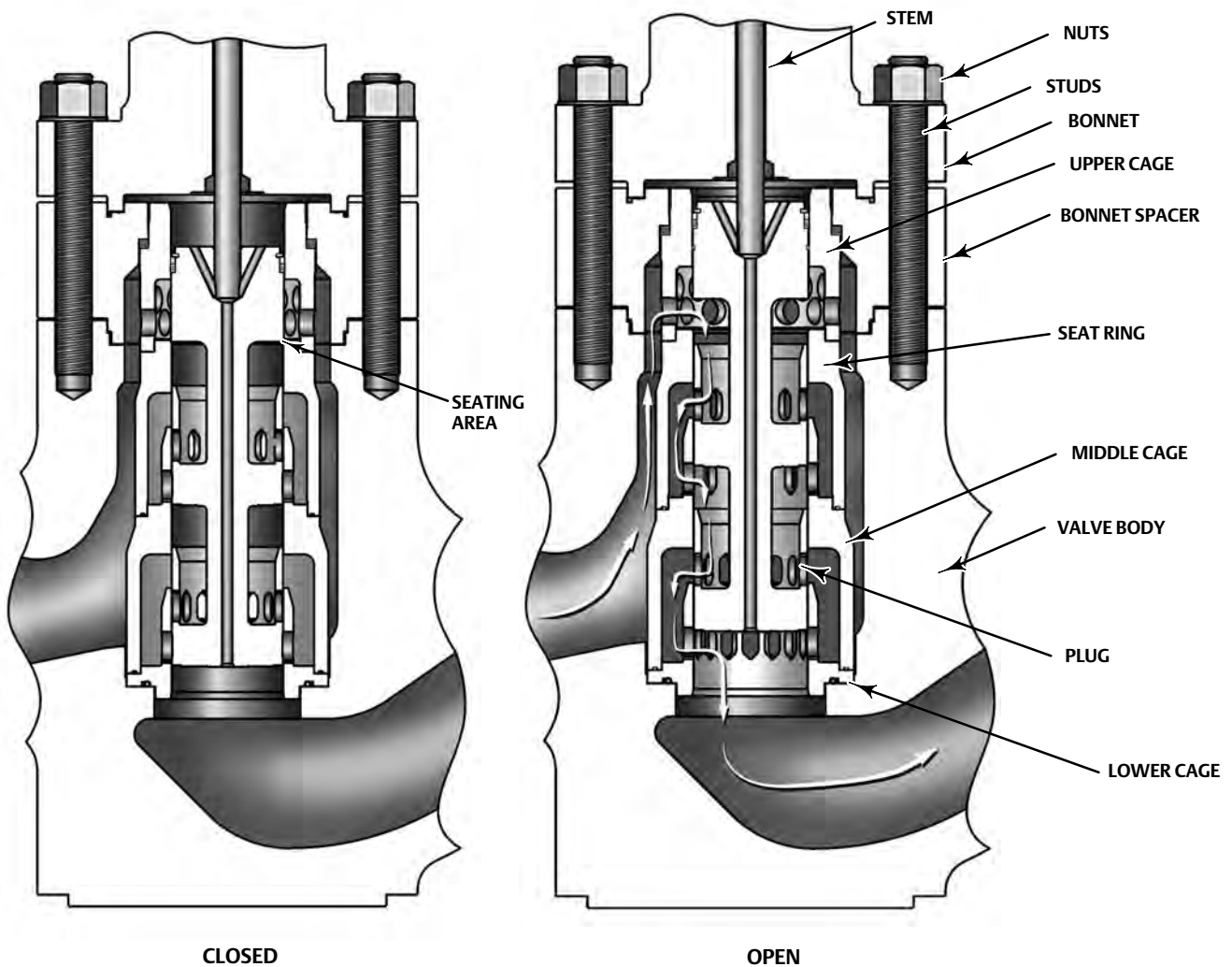

Figure 3. 3-Stage Fisher DST Flow Up Trim

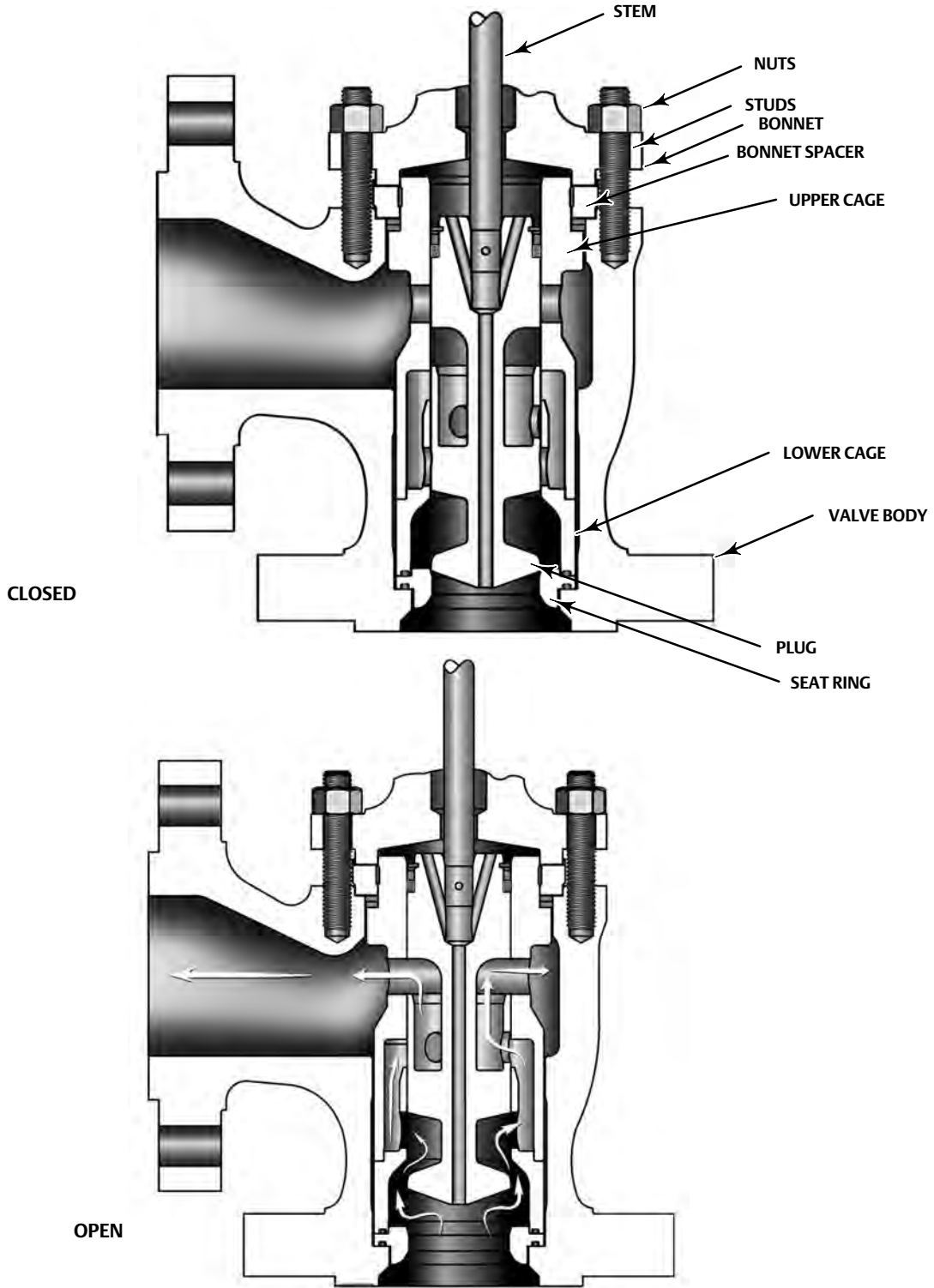

Table 4. Typical Applications

POWER/COGENERATION	Boiler feed pump recirculation
	Desuperheater spray water control
	Feedwater start-up regulators
	Condensate pump recirculation
	Superheater bypass
OIL AND GAS PRODUCTION	Water injection pump recirculation
	Produced/waste water injection well control
	Separator letdown
	Chemical injection pump bypass
	Main oil line or export flow control valve
NATURAL GAS PROCESSING	Main oil line or export pump recirculation
	Contactora (rich amine) letdown
REFINING	Rich and lean amine pump spillback
	Contactora letdown
	Rich and lean amine pump spillback
	Pump spillback/recirculation
	Various high pressure and low pressure separator letdown

Neither Emerson, Emerson Automation Solutions, nor any of their affiliated entities assumes responsibility for the selection, use or maintenance of any product. Responsibility for proper selection, use, and maintenance of any product remains solely with the purchaser and end user.

Fisher and easy-e are marks owned by one of the companies in the Emerson Automation Solutions business unit of Emerson Electric Co. Emerson Automation Solutions, Emerson, and the Emerson logo are trademarks and service marks of Emerson Electric Co. All other marks are the property of their respective owners.

The contents of this publication are presented for informational purposes only, and while every effort has been made to ensure their accuracy, they are not to be construed as warranties or guarantees, express or implied, regarding the products or services described herein or their use or applicability. All sales are governed by our terms and conditions, which are available upon request. We reserve the right to modify or improve the designs or specifications of such products at any time without notice.

Emerson Automation Solutions
Marshalltown, Iowa 50158 USA
Sorocaba, 18087 Brazil
Cernay, 68700 France
Dubai, United Arab Emirates
Singapore 128461 Singapore

www.Fisher.com

