

Fisher[®] FIELDVUE[™] DVC6000 SIS Digital Valve Controllers for Safety Instrumented System (SIS) Solutions

The operation of many industrial processes, especially in the chemical and oil & gas industries, involves inherent risk. Safety Instrumented Systems are specifically designed to reduce the likelihood or the severity of the impact of an identified event, thus helping to protect personnel, equipment, and the environment. These systems involve final control elements, which are mostly held in one position and requested to move only when an emergency situation arises. Typical applications with Safety Instrumented Systems involve Emergency Shutdown Valves, Emergency Blow Down Valves, Emergency Venting Valves, Emergency Isolation Valves, Critical On-Off Valves, etc. Because the final control element remains in one position without mechanical movement, the dependability of the valve is reduced because there is a chance it may not operate successfully upon demand. This could cause a potentially dangerous condition leading to an explosion or fire and the leaking of lethal chemicals and gases to the environment.

Emerson Process Management offers a solution for Safety Instrumented System (SIS) valves that use FIELDVUE DVC6000 SIS digital valve controllers (see figure 1). Using the DVC6000 SIS permits partial stroking of the valve to reduce the Probability of Failure on Demand (PFD) and, consequently, the possibility of catastrophic situations. Partial stroking tests the final control element with a small amount of valve travel. This movement is small enough not to disrupt production, but large enough to confirm that the valve is working. DVC6000 SIS digital valve controllers also provide state-of-the-art testing methods, which reduce testing and maintenance time and initial investment cost, improve system performance, and provide diagnostic capabilities.



W8308-3 SIS

Figure 1. FIELDVUE DVC6030 SIS Digital Valve Controller Mounted on a Quarter-Turn Actuator

Features

- **Increased System Availability**—The simple and secure method of partial stroke testing allows end-users to perform more frequent valve mechanical movement tests. This reduces the PFD factor. Because the test procedures are flexible, they can be conducted at any time, providing more assurance the system will be available upon demand. In addition, continuous valve monitoring through Fisher ValveLink[™] software provides awareness of the valve's status.
- **Reduced Cost of Ownership**—Lower base equipment cost with considerable reduction in testing time and a reduced manpower requirement makes this solution economically feasible. DVC6000 SIS digital valve controllers offer an economic



alternative to expensive pneumatic test panels and skilled personnel presently required for testing Safety Instrumented System valves.

- Valuable Time Savings**—Remote testing capability requires fewer maintenance inspection trips to the field thus saving considerable time. Using ValveLink software’s Batch Runner to establish an automatic test routine can also provide increased time savings. Batch Runner increases efficiency by allowing you to set up a batch once, and repeatedly run that set of actions on different groups of valve assemblies.

- Predictive Maintenance**—DVC6000 SIS instruments permit using ValveLink software to provide Valve Degradation Analysis, which is important for critical valves in shut down systems. This may also reduce the amount of scheduled maintenance.

- Valve Stuck Alert**—While performing the partial stroke test, if for any reason the valve is stuck, the digital valve controller will not completely exhaust the actuator pressure. This reduces the likelihood that the valve will slam shut should it become unstuck. The digital valve controller will abort the test and set an alert indicating that the valve is stuck. The alert is accessible via HART® communication.

Note

HART communication is available through the use of ValveLink software, a portable handheld device such as a 475 or 375 Field Communicator, or a HART capable host. HART capable hosts include, but are not limited to, DeltaV SIS™ and the non-integrated Moore HART Loop Interface and Monitor (HIM).

- System Audit Documentation**—Using ValveLink software provides a time and date stamp on all tests and reports, which is important for documenting compliance with the requirements of statutory authorities.

- Verification**—ValveLink software provides the capability for comparing and interpreting diagnostic data.

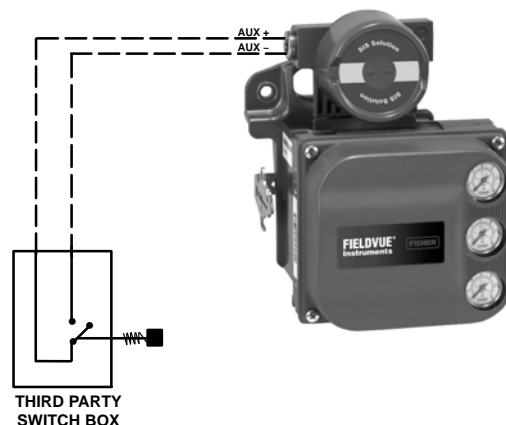

E1029

Figure 2. Initiate the Partial Stroke Test from a Push Button

- Partial Stroke Testing**—DVC6000 SIS digital valve controllers allow a partial stroke test which ramps valve travel a small amount while the valve is in-service and operating. Should a demand arise during the test, the test is overridden immediately and the valve moves to the safe state. The partial stroke test can reduce costly, labor intensive testing techniques. The simplicity of this automated test allows for more frequent online testing. More frequent testing enhances loop availability and increases the reliability of the system.

Once initiated, the automated test moves the valve to a predetermined value then returns the valve to its original position. The default value for valve movement is 10% from its original position, but can be custom set to any value up to 30% to meet plant safety guidelines.

The partial stroke test can be automatically scheduled and initiated by the device itself or it can be performed manually.

User Initiated Partial Stroke Testing—The partial stroke test can be scheduled and initiated by an authorized technician with ValveLink software. The technician may also initiate the test by shorting the AUX Terminal with an external push button (figure 2), or by using an LCP100 local control panel (shown in figure 18) or a Field Communicator. Initiating the test does not require removing any instrument covers or being near the valve during the test.

A partial stroke test can be initiated when the valve is operating at either 4 or 20 mA (point-to-point mode). In applications where a spurious trip is to be minimized, 4 mA is the normal operating position.

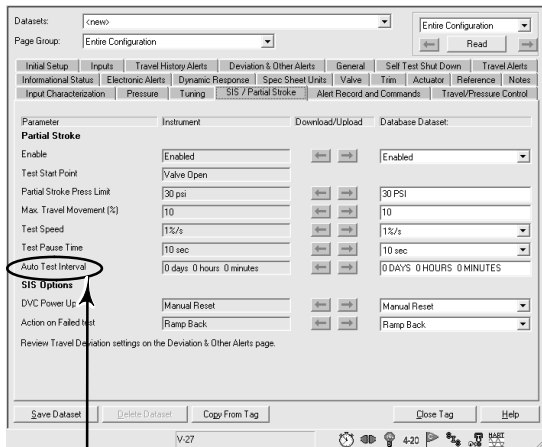

AUTO TEST INTERVAL
DETAILED SETUP > SIS / PARTIAL STROKE

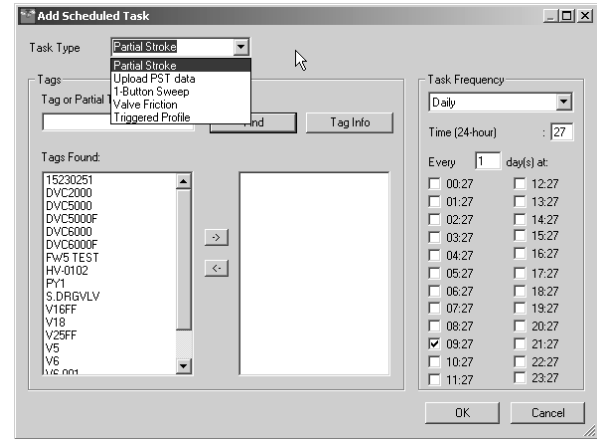

SCHEDULER

Figure 3. Configuring Partial Stroke Test using ValveLink Software

Device Initiated Partial Stroke Test—The partial stroke test can be scheduled by ValveLink software to be run by the device on a periodic basis.

The SIS / Partial Stroke **Auto Test Interval** (figure 3) is used to configure the device to automatically run the partial stroke test on a days, hours, minutes basis without user intervention.

Scheduler allows you to schedule the partial stroke test to run on a recurring daily, weekly, monthly, or yearly schedule that you specify, as shown in figure 3.

Configuring the time interval between tests for a device initiated partial stroke test automates the process. Data resulting from device initiated partial stroke tests is available for later viewing and analysis using ValveLink software.

- **Redundant Control of Final Control Element**—When used in conjunction with a solenoid valve, as shown in figures 10 and 13, DVC6000 SIS digital valve controllers provide an inherent redundant pneumatic path. Should an emergency situation arise, the actuator pressure exhausts through either the solenoid valve or through the digital valve controller, allowing the valve to move to the safe position.

- **Reduced Wiring Cost**—DVC6000 SIS instruments eliminate the need for position transmitters and separate wiring from the transmitter. Through HART communications protocol, the valve position is communicated over

the same 4–20 mA analog loop that provides the valve control signal. A HART-to-analog signal converter in the control room can provide a 4–20 mA signal that is proportional to valve position. The HART-to-analog signal converter can also provide discrete contact outputs to the logic solver, which may replace hard-wired limit switches.

- **Device Integrity Continuously Checked**—When “End Point Pressure Control Mode” is enabled, the digital valve controller remains constantly in control while the valve is at its normal position (either fully open or fully closed); it is not allowed to reach a saturated state. The digital valve controller constantly tests its internal components, and if any component fault is detected, it sets an alert which may be accessed via HART communication.

- **Manual Reset**—The DVC6000 SIS can be configured to hold the tripped state until a local reset button is pressed. Manual reset can be initiated by pressing the built-in button on the optional Fisher LCP100 local control panel. Alternatively, if the LCP100 is not used, a user-supplied push button can be used to short the AUX terminals.

- **Trigger Functionality**—Data can be collected and stored in the memory of the DVC6000 SIS digital valve controller. Trip event data can be accessed for an audit and presented to a regulatory or insurance authority when the DVC6000 SIS operates with 4–20 mA. The trigger will initiate on-board data collection based on a change in actuator pressure, valve travel, input current,

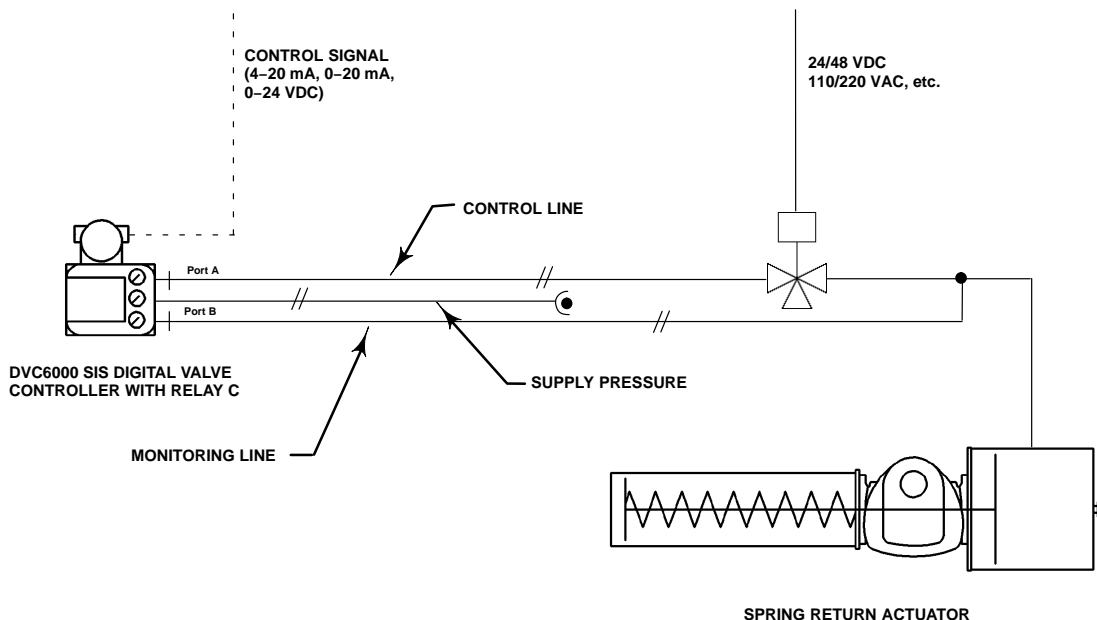

E1048

Figure 4. Pneumatic Hookup for Solenoid Testing

pressure differential, travel deviation, travel cutoff, or auxiliary input/external trigger. The data is stored on board the device for later retrieval, and is retained in the event of a power loss.

- Solenoid Testing**—When a solenoid valve is installed between the DVC6000 SIS pressure output and the actuator, the control valve assembly can be configured to verify the operation of the solenoid valve. In single acting actuator applications, the “unused” output port of the DVC6000 SIS can be piped such that the pressure downstream of the

solenoid valve is measured (see figure 4). When the solenoid valve is pulsed, the DVC6000 SIS can sense the momentary pressure drop across the solenoid valve, as shown in figure 5. If the pulse is short enough, the emergency shutdown valve will not move or disrupt the process. This not only increases the availability of the solenoid valve during a safety demand, but also enhances the reliability of the SIF (Safety Instrumented Function) loop.

- Spurious Trip Protection**—The DVC6000 SIS digital valve controller can be supplied with a reverse acting relay to provide maximum output pressure at minimum input signal. This solution provides trip protection because loss of control signal will not cause the valve to trip (i.e. the relay stays at maximum output pressure).

In point-to-point mode (where the DVC6000 SIS is powered with 4 mA), the valve can be taken to its fail safe position by applying 20 mA.

In multi-drop mode (where the DVC6000 SIS is powered with 24 VDC), a solenoid valve will be required to take the final control element to its fail safe position.

- Valve Signature**—A valve signature obtained with ValveLink software can be used to easily determine valve packing problems (through friction data), leakage in the pneumatic pressurized path to the actuator (through the Pressure vs. Travel graph), valve sticking, actuator spring rate, and bench set.

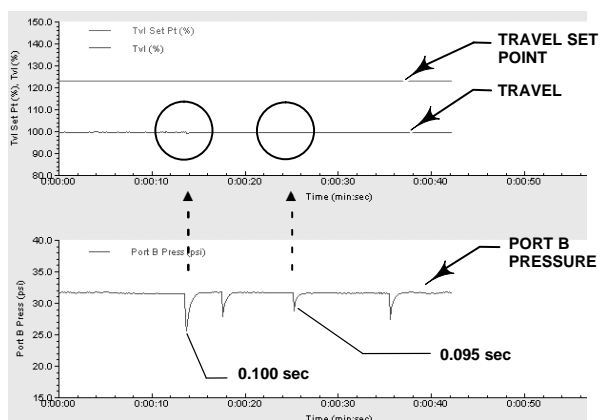

E1028

Figure 5. ValveLink Software Screen Image Showing Pressure Drop Across the Solenoid Valve

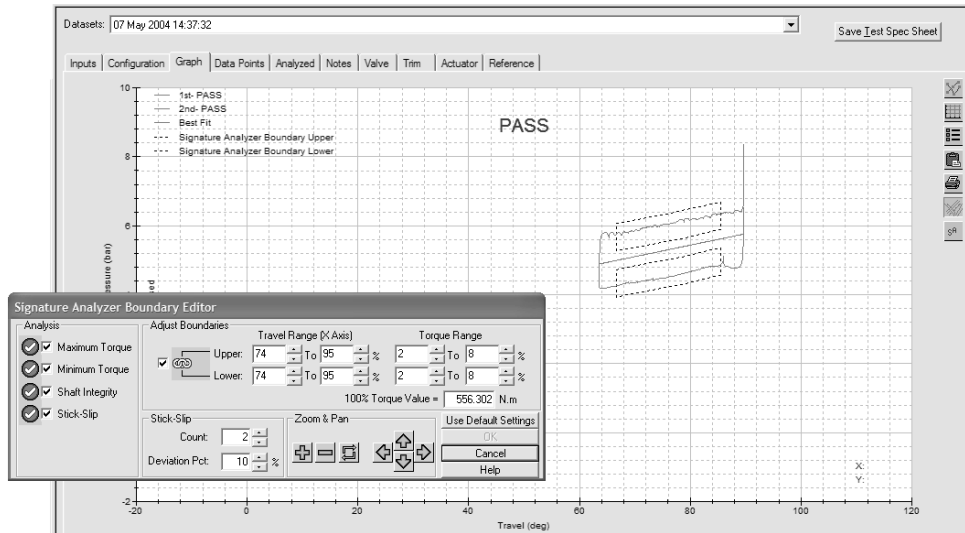

Figure 6. Valve Signature and Analysis Obtained from Partial Stroke Test on an SIS Valve

Any time a partial stroke test is run on the valve, a partial stroke valve signature and analysis, shown in figure 6, is available. Comparing valve signature results can be used to determine if valve response has degraded over time.

In addition, when the valve is not online, several full stroke valve diagnostic tests can be run, including valve signature, dynamic error band, and step response. ValveLink software enables simultaneous multiple overlay of up to ten tests (partial stroke test or dynamic scan or a combination of both tests) and allows end-user capability to trend valve history. Pressure and travel vs. time plot provides the exact status of the valve movement, helping to critically analyze events like a “Safety Demand”. These tests can also be used to evaluate valve performance, such as stroking time and shutoff capability. Running these tests when the valve is first installed in the safety system allows establishing a bench mark for valve performance. The results of these tests can be compared to results from later tests to determine if valve performance has degraded.

- **Travel Record**—The cycle counter and travel accumulator provide a record of the number of cycles and percentage of travel accumulated over time.

- **Alerts**—All device alerts are available via HART communication. Alerts are immediately available and logged if ValveLink software is set up for alert scanning. Alerts are also stored in an alert record in the instrument. Alerts in the alert record

can be retrieved using a Field Communicator or ValveLink software. Each alert is recorded with a time and date stamp to allow the operator to determine the nature of the alert and when it occurred.

- **Alert Notification**—Event Messenger, part of the Network Alert Scan feature in ValveLink Solo, allows notifying key people of critical alerts via e-mail. ValveLink Solo can be set up to automatically send an e-mail when a specified alert occurs on a final control element in a Safety Instrumented System (figure 7). This e-mail could also be set up to send a text message. The capability can be set up to notify a designated technician if a specific alert, or sets of alerts, occurred on a predefined set of safety shutdown valves. This means key plant operation personnel can be continuously informed of alert status, no matter where they are, enabling them to provide more timely and precise corrective action.

- **Adjustable Travel Cutoff**—Travel Cutoffs are adjustable when the DVC6000 SIS is operating with a 4–20 mA current. The Setup Wizard automatically sets travel cutoffs at 50%, making the DVC6000 SIS work like an on-off device. At current levels from 4–12 mA (nominal), the DVC6000 SIS will provide minimum output pressure, and at 12–20 mA, the DVC6000 SIS will provide full output pressure.

You can customize valve response to the control signal by changing the travel cutoffs. For example, it

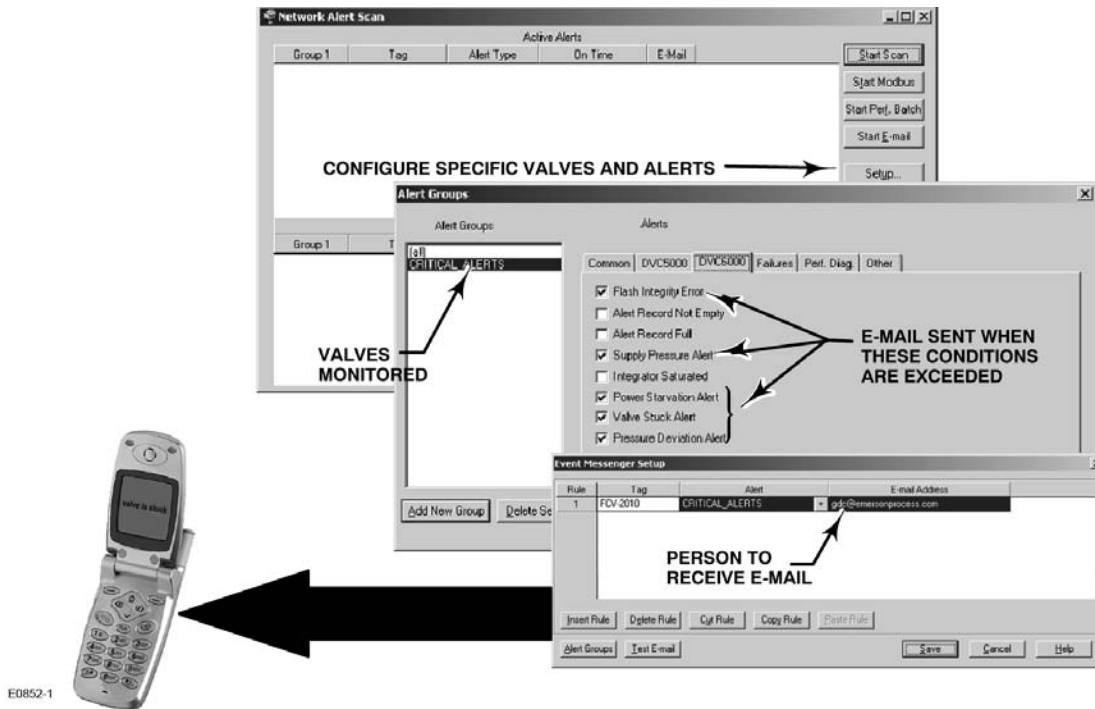

Figure 7. Notify Key People via E-Mail whenever a Specified Alert Occurs on a Safety Shutdown Valve

is possible to have the valve throttle between 10 and 90% open, but work as an on-off valve between 0% to 10% and 90% to 100% opening. Therefore you could have a throttling control valve when the control signal is between 10% and 90% open, but an SIS on/off valve when the control signal is outside of this range. In this example, when the control signal is greater than 90%, the SIS functions of partial stroke testing and pressure control mode can be enabled.

- **Travel Characterization**—The DVC6000 SIS provides flexibility to configure quick open, linear, equal percentage, or custom characterization.

- **Signature Analyzer**—An additional diagnostic is available through ValveLink software for the possible indication of a broken shaft or stem, as shown in figure 8. Stick-Slip, a new diagnostic also available through ValveLink software (see figure 9), is used to indicate inherent dead motion and degraded performance.

- **Enhanced Tuning Capabilities**—Large size valves and actuators are often equipped with air accessories to improve stroking speed requirements. DVC6000 SIS firmware has simple parameter choices to allow the operator to more easily tune valves with accessories.

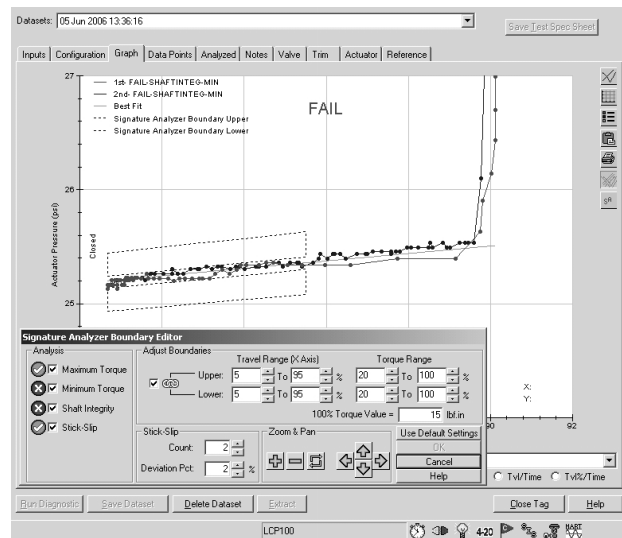

E1037

Figure 8. Broken Shaft or Stem Diagnostic, available through ValveLink Software

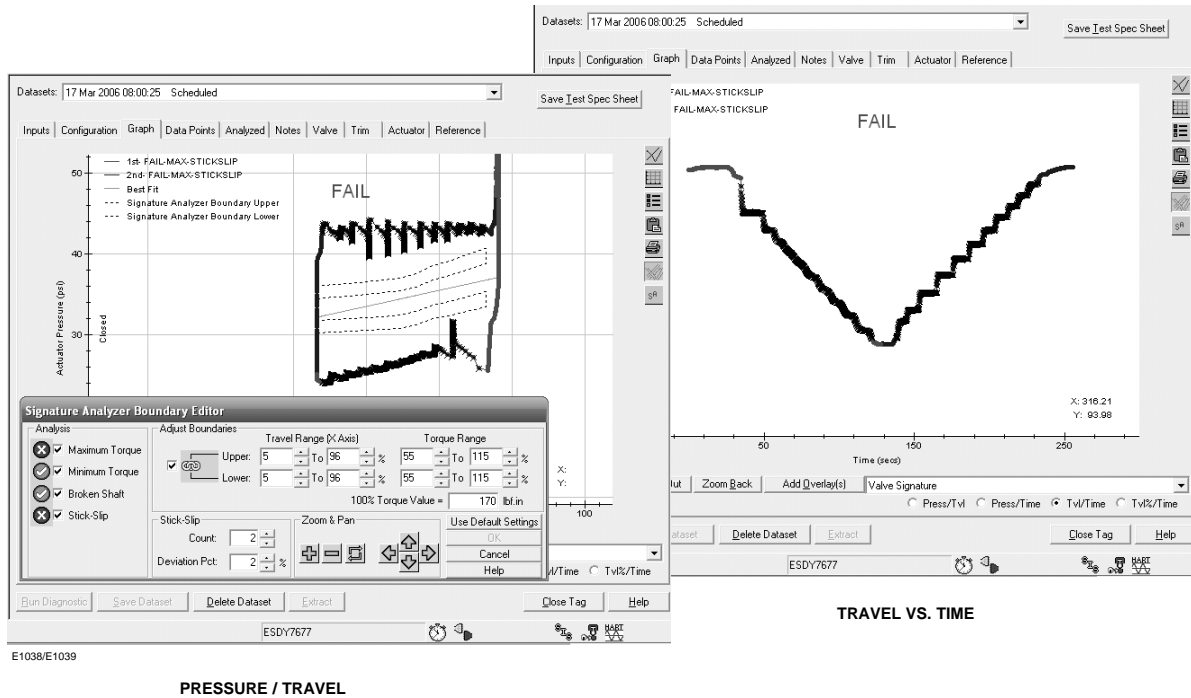

Figure 9. Stick-Slip Diagnostic, available through ValveLink Software

Installing DVC6000 SIS Instruments in SIS Systems

DVC6000 SIS instruments can be extended to any valve style configuration including sliding-stem, rotary, quarter-turn, etc. with spring and diaphragm actuators or spring-return piston actuators so long as the actuator system was designed so that it will move the valve to the safe state. A spring return actuator is normally used. An extensive number of mounting kits have been designed to work with actuators produced by various manufacturers.

Two types of installation are possible:

- **2-wire system**
- **4-wire system**

Installations with the digital valve controller in 2-wire systems (multi-drop mode) are shown in figures 10, 11, and 12. In installations that include a solenoid

valve with the digital valve controller, the logic solver provides a single 24 volt DC source to provide power for both the solenoid valve and the digital valve controller. Installations with the digital valve controller in a 4-wire system (point-to-point mode) are shown in figure 13. These installations require two separate sources: a 24 volt DC source (from the Logic Solver) for the solenoid valve and a 4–20 mA DC current source (either from the Logic Solver or the DCS control system) for the digital valve controller.

In installations that include a solenoid valve, a redundant pneumatic path exists, i.e., the actuator pressure will always be able to exhaust to allow the valve to move to the safe position. If the solenoid valve fails, the actuator pressure will exhaust through the digital valve controller. If the digital valve controller fails, the actuator pressure will exhaust through the solenoid valve. If necessary, the solenoid valve can have larger ports to allow the safety shutdown valve to meet any response time criteria.

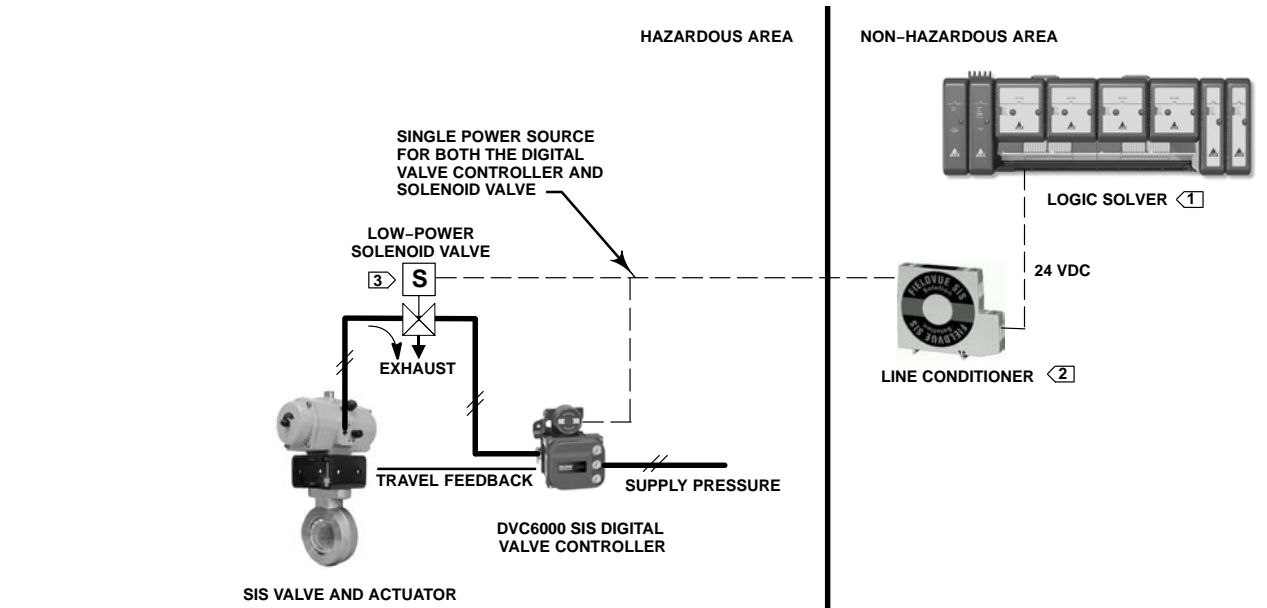

NOTE:
 1 A LOGIC SOLVER, IF REQUIRED, CAN BE PROVIDED BY EMERSON PROCESS MANAGEMENT. CONTACT YOUR LOCAL SALES OFFICE.
 2 LINE CONDITIONER OR 250 OHM IMPEDANCE TO PERMIT HART COMMUNICATION.
 3 IF SHARING 24 VOLT DC SIGNAL IS NOT PERMISSIBLE, THE SOLENOID VALVE MAY BE ELIMINATED, AS SHOWN IN FIGURE 11.
 E0514-
 *

Figure 10. Safety Instrumented System Schematic with FIELDVUE DVC6000 SIS Digital Valve Controller in 2-Wire System

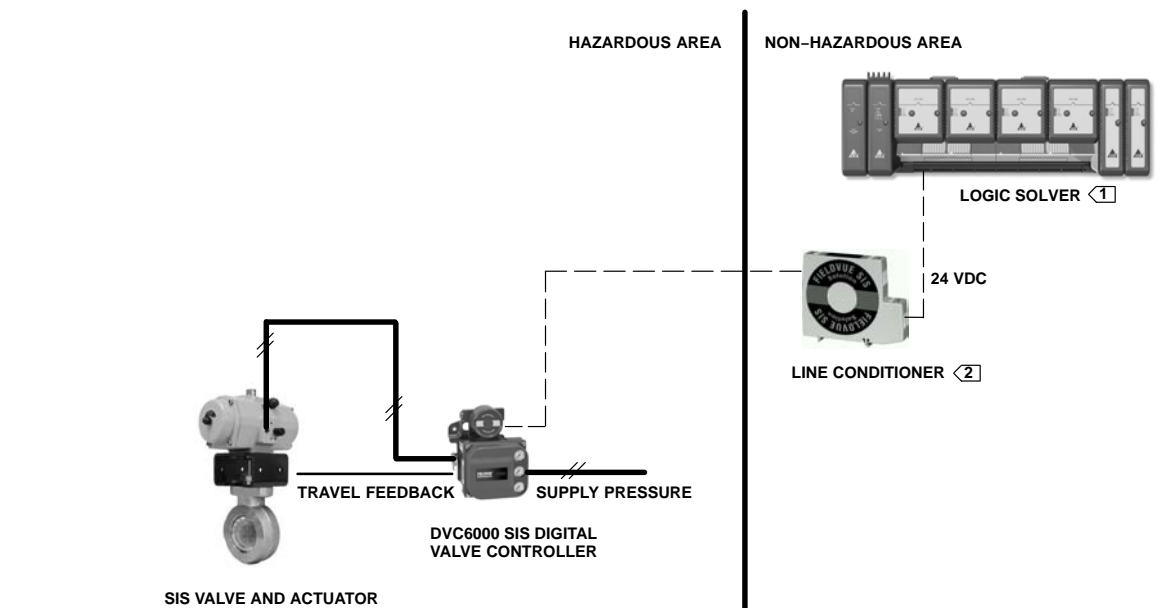

NOTE:
 1 A LOGIC SOLVER, IF REQUIRED, CAN BE PROVIDED BY EMERSON PROCESS MANAGEMENT. CONTACT YOUR LOCAL SALES OFFICE.
 2 LINE CONDITIONER OR 250 OHM IMPEDANCE TO PERMIT HART COMMUNICATION
 E0845-2

Figure 11. Safety Instrumented System Schematic with FIELDVUE DVC6000 SIS Digital Valve Controller in 2-Wire System; 24 VDC (See figure 10 for alternate installation with solenoid valve)

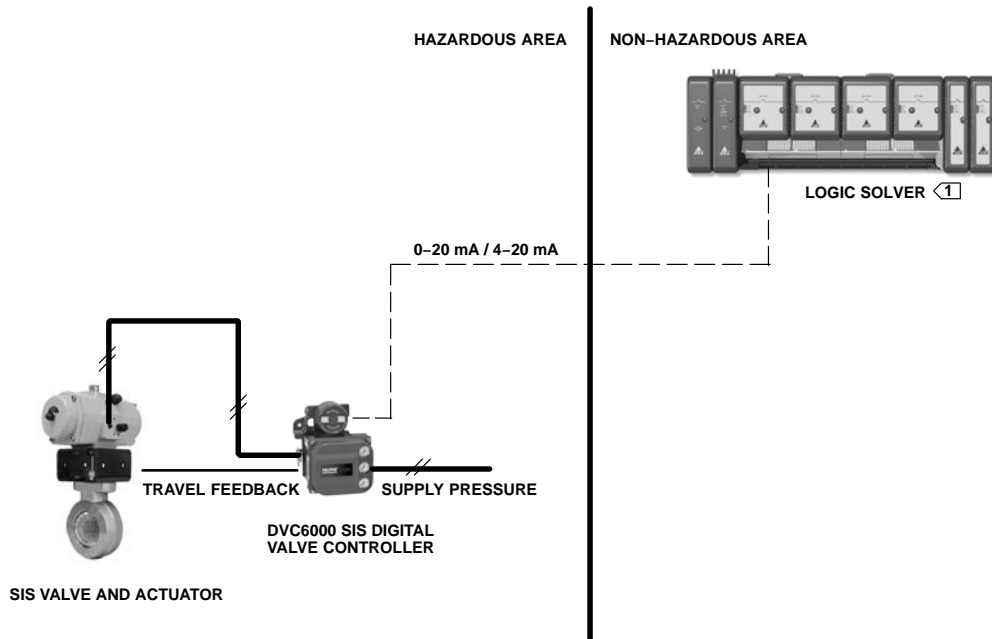

NOTE:
 [1] A LOGIC SOLVER, IF REQUIRED, CAN BE PROVIDED BY EMERSON PROCESS MANAGEMENT. CONTACT YOUR LOCAL SALES OFFICE.
 E1120

Figure 12. Safety Instrumented System Schematic with FIELDVUE DVC6000 SIS Digital Valve Controller in 2-Wire System, 0-20 mA/4-20 mA

2-wire system installations:

- Reduce wiring cost for new installations or no additional wiring cost for existing installations
- Save an I/O card in the control room
- Require an LC340 line conditioner to allow HART communication to a Field Communicator or ValveLink software. The LC340 adds an approximate 2 volt DC line drop in installations that include a solenoid valve.
- Require a low-power solenoid valve if the installation includes a solenoid valve
- Require the DVC6000 SIS to be configured in multi-drop mode

4-wire system installations:

- Permit the digital valve controller to continue to communicate even during emergency conditions (on demand). This allows the digital valve controller to provide valuable trending information through ValveLink Software. Being able to record the valve action can provide important evidence that the valve did stroke upon demand.
- Require an additional pair of wires
- Permit the use of existing solenoid valves which may be powered with 48 volts DC, 120 volts AC, etc.
- Allow the DVC6000 SIS to be configured in either point-to-point or multi-drop mode

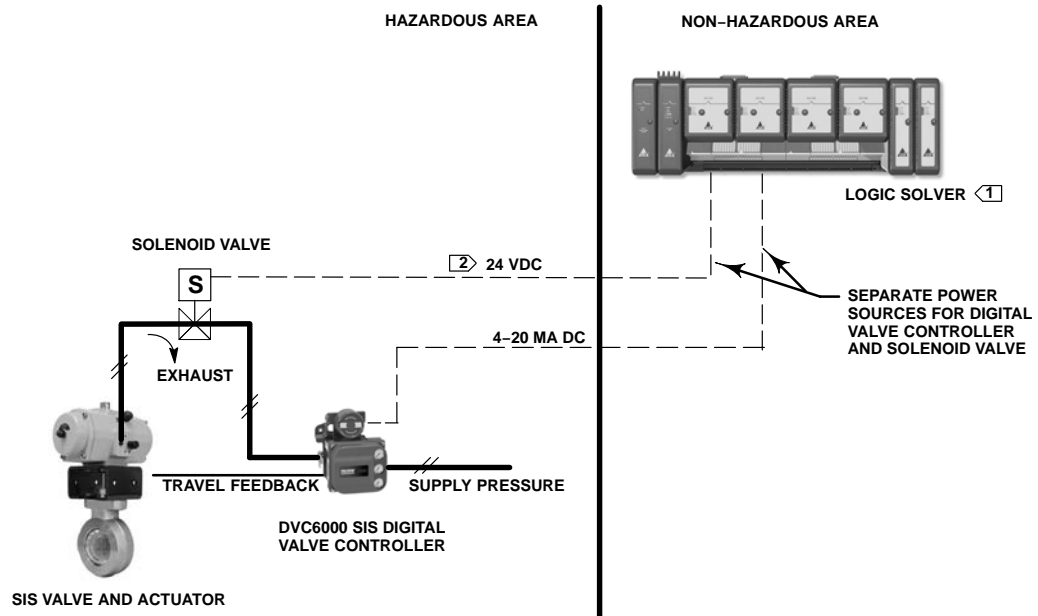

NOTE:
 1 A LOGIC SOLVER, IF REQUIRED, CAN BE PROVIDED BY EMERSON PROCESS MANAGEMENT. CONTACT YOUR LOCAL SALES OFFICE.
 2 EXISTING SOLENOID VALVE MAY BE USED. DEPENDING UPON SOLENOID VALVE, LOGIC SOLVER WOULD NEED TO SUPPLY OPERATING POWER FOR SOLENOID VALVE (120 VAC, 48 VDC, ETC.).
 E0513-3

Figure 13. Safety Instrumented System Schematic with FIELDVUE DVC6000 SIS Digital Valve Controller in 4-Wire System

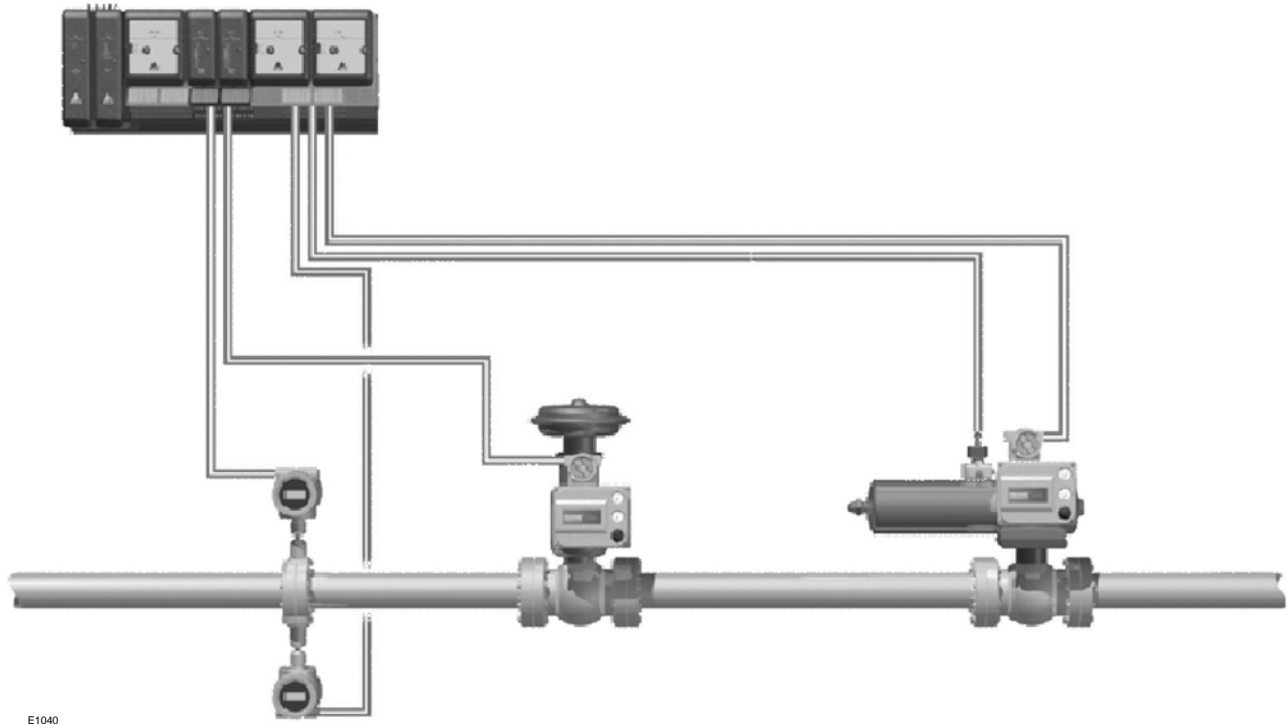

Figure 14. DeltaV™ SIS Solution

Valve and Actuator Selection

To be compliant in a Safety Instrumented System, the valve assembly should be of fire-safe design and should meet the design criteria of API 607 and API 6D. Butterfly valves, such as the Fisher A11, A31D, or 8560, are designed to meet the above standards. If the requirement is for a full-bore ball valve with fire-safe design criterion, select an appropriate vendor. These are only guidelines for selecting valves and actuators for an SIS application. For more specific details, contact your Emerson Process Management sales office.

SIL-PAC™ Final Control Solution for Safety Systems

The Emerson Process Management SIL-PAC is a complete integrated, Final Control Solution for Safety Systems. SIL-PAC includes Emerson Valve Automation's range of actuators, including the Bettis™ Scotch Yoke Series (G & CBA) and the rack

and pinion family (Hytork™, EI-O-Matic™, FieldQ™, and Bettis). SIL-PAC integrates these actuators with the applicable controls and mounts them to the customer specified valve body for a complete Final Control Solution. Incorporating the reliability of the industry leading actuators with the diagnostics and functionality of a Fisher digital valve controller, the DVC6000 SIS makes the package a smart SIL-PAC and an integral part of the Emerson Smart SIS. The smart SIL-PAC provides diagnostics for the entire package, partial stroke testing, and all of the familiar features available through the DVC6000 SIS digital valve controller. SIL-PAC includes documentation, testing, technical support, and a certification per industry standards authenticated by a third party, providing functional safety assessment and application criteria (see figure 15). The SIL-PAC Solution, complete with desired functionalities and added value required for use in safety instrumented function (SIF) loops of Safety Instrumented Systems (SIS), allows flexibility, reduced cost, improved reliability, and a familiar single point of contact.

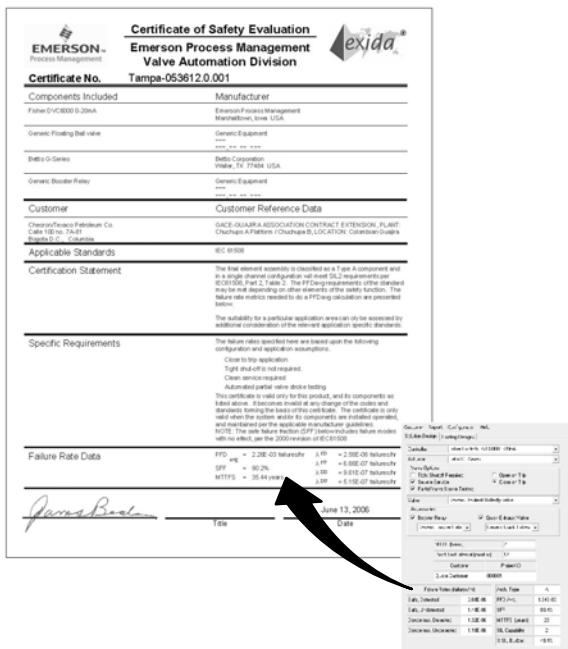

E1041

Figure 15. SIL-PAC Certificate of Safety Evaluation

Integrated Solution—Smart SIS from Emerson Process Management

With the introduction of DeltaV SIS (Logic Solver) and transmitters (sensor) from Emerson Process Management (see figure 14), a complete integrated solution can be provided for SIS applications, enabling the SIF (Safety Instrumented Function) loop to increase safety while decreasing spurious trips, thereby increasing the reliability from the sensor to the final control element. This integrated approach helps to provide easy regulatory compliance, reduced project capital and maintenance cost, increased system availability by better management of SIF components and easy documentation audit. For more details, contact your Emerson Process Management sales office.

exida® Certification

exida has certified that the DVC6000 SIS digital valve controller, when operating in a Safety Instrumented System with a 4–20 mA, 0–24 VDC, or



Figure 16. exida Certificate

0–20 mA input signal from a logic solver, meets the requirements of IEC61508, and can be incorporated into Safety Instrumented Function (SIF) loops that are rated to Safety Integrity Level 3 (SIL3). This certification includes relays A and C, and stainless steel, remote mount, extreme temperature, and natural gas certified options. The LCP100 local control panel is covered under this certification as a non-interfering device to the safety function. The certificate is shown in figure 16.

TÜV Certification

TÜV has certified that DVC6000 SIS digital valve controller hardware, when operating in a Safety Instrumented System with a 0–24 volt DC or 0–20 mA DC control signal, meets the requirements of IEC 61508, and can be incorporated into Safety Instrumented Function (SIF) loops that are rated to Safety Integrity Level 3 (SIL3). The certificate is shown in figure 17.



Figure 17. TÜV Certificate



W9370

Figure 18. Fisher LCP100 Local Control Panel; Electrically Connects to the FIELDVUE DVC6000 SIS Digital Valve Controller

DVC6000 SIS Installation

The DVC6010 SIS digital valve controller is designed for yoke mounting to sliding-stem actuators. DVC6020 SIS digital valve controllers are designed for mounting to rotary actuators or long-stroke sliding-stem actuators (over 4 inches travel). DVC6030 SIS digital valve controllers are designed for mounting on virtually any quarter-turn actuator. Refer to Bulletin 62.1:DVC6000(S1) FIELDVUE DVC6000 Digital Valve Controller Dimensions (D103308X012) for dimensional information.

The DVC6005 SIS digital valve controller base unit may be remote-mounted on 2 inch pipestand or wall. The remote-mount DVC6005 SIS base unit connects to the DVC6015, DVC6025, or DVC6035 feedback unit mounted on the actuator. Feedback wiring and pneumatic tubing to the control valve assembly must be connected in the field.

The digital valve controllers are loop-powered and do not require additional power. Electrical connections are made in the terminal box.

All pressure connections on the digital valve controllers are 1/4 NPT internal connections. The digital valve controller outputs are typically connected to the actuator inputs using 3/8-inch diameter tubing. Remote venting is available.

LCP100 Local Control Panel

The LCP100 local control panel, shown in figure 18, is electrically connected with the DVC6000 SIS digital valve controller. The LCP100 can be powered by the loop current used to power the DVC6000 SIS (requires 8 mA minimum total loop current in this case) or it can have an independent 24 VDC power supply. By use of push buttons on the local control panel, commands can be sent to the DVC6000 by which Safety Shut Down valves can be opened, closed, or tested. The local control panel also has three lights, indicating normal operating position (green), tripped or fail-safe state (red), and ready-to-reset (amber) status.

The integration of the LCP100 with the DVC6000 SIS can provide considerable savings in the number of I/O's from the control room (possibly up to five) to achieve the desired functionalities. This can provide a reduction in capital and operational costs, as well as fewer maintenance issues.

The LCP100 has two power supply options:

a. *Loop-Powered (8–20 mA)*—An 8–20 mA input signal from the DCS or Logic Solver to the DVC6000 SIS provides power to the LCP100. To provide power to the local control panel the minimum input signal from the DCS or Logic Solver must be 8 mA. No external power source is required.

b. *External Power*—A 24 VDC power supply is required to power the LCP100.

Ordering Information

Refer to the Specifications section. Carefully review each specification and indicate your choice whenever a selection is to be made.

When ordering, specify:

1. Digital valve controller type number
2. DVC6000 power [24 VDC (multi-drop) or 4–20 mA current loop (point-to-point)]
3. Valve style (sliding-stem or rotary)
4. Actuator (spring and diaphragm or piston with spring return)
5. Actuator manufacturer (Fisher or other)
6. Actuator type and size
7. Positioner Action (pneumatic relay) – Direct / Reverse
8. Valve failure action (fail close or fail open)
9. Mechanical position indicator, if required
10. LCP100 local control panel, if required

Related Documents

These documents are available from your Emerson Process Management sales office. Also visit our website at www.FIELDVUE.com.

- TÜV Certificate Nr./No. 968/EZ 127.00/02
- TÜV Report for DVC6000 SIS—No. 968/EZ 127.00/02
- FMEDA Report for DVC6000 SIS– Form 5742
- FMEDA Report for LC340 Line Conditioner – Form 5749
- Bulletin 62.1:DVC6000(S1) – FIELDVUE DVC6000 Digital Valve Controller Dimensions (D103308X012)
- FIELDVUE DVC6000 SIS Digital Valve Controllers for Safety Instrumented System (SIS) Solutions Instruction Manual (D103230X012)
- FIELDVUE DVC6000 SIS Digital Valve Controllers for Safety Instrumented System (SIS) Solutions Quick Start Guide (D103307X012)

DVC6000 SIS Specifications

Available Configurations

Valve-Mounted Instrument:

DVC6010 SIS: Sliding-stem applications
DVC6020 SIS: Rotary applications and long-stroke sliding-stem applications
DVC6030 SIS: Quarter-turn rotary applications

All units can be used in either 4-wire or 2-wire system installations.

DVC6000 SIS digital valve controllers must have the Safety Instrumented System Application (SIS) option

Remote-Mounted Instrument⁽¹⁾:

DVC6005 SIS: Base unit for 2 inch pipestand or wall mounting
DVC6015: Feedback unit for sliding-stem applications
DVC6025: Feedback unit for rotary or long-stroke sliding-stem applications
DVC6035: Feedback unit for quarter-turn rotary applications

DVC6000 digital valve controllers can be mounted on Fisher and other manufacturers rotary and sliding-stem actuators.

Input Signal

Point-to-Point

Analog Input Signal: 4–20 mA DC, nominal
Minimum Voltage Available at Instrument
Terminals must be 10.5 volts DC for analog control, 11 volts DC for HART communication (see instrument instruction manual for details)
Minimum Control Current: 4.0 mA
Minimum Current w/o Microprocessor Restart: 3.5 mA
Maximum Voltage: 30 volts DC
Overcurrent Protection: Input circuitry limits current to prevent internal damage
Reverse Polarity Protection: No damage occurs from reversal of loop current

Multi-drop

Instrument Power: 11–30 volts DC at approximately 8 mA
Reverse Polarity Protection: No damage occurs from reversal of loop current

Output Signal

Pneumatic signal as required by the actuator, up to 95% of supply pressure

Minimum Span: 0.4 bar (6 psig)
Maximum Span: 9.5 bar (140 psig)
Action: ■ Double, ■ Single Direct, and ■ Single Reverse

Supply Pressure⁽²⁾

Minimum Recommended: 0.3 bar (5 psig) higher than maximum actuator requirements
Maximum: 10.0 bar (145 psig) or maximum pressure rating of the actuator, whichever is lower

Supply Medium

Air: Supply pressure must be clean, dry air that meets the requirements of ISA Standard 7.0.01. A maximum 40 micrometer particle size in the air system is acceptable. Further filtration down to 5 micrometer particle size is recommended. Lubricant content is not to exceed 1 ppm weight (w/w) or volume (v/v) basis. Condensation in the air supply should be minimized

Natural Gas: Natural gas must be clean, dry, oil-free, and noncorrosive. H₂S content should not exceed 20 ppm.

Steady-State Air Consumption⁽³⁾⁽⁴⁾

Low Bleed Relay:

At 1.4 bar (20 psig) supply pressure: Average value 0.056 normal m³/hr (2.1 scfh)
At 5.5 bar (80 psig) supply pressure: Average value 0.184 normal m³/hr (6.9 scfh)

The low bleed relay is the standard relay for the DVC6000 SIS, used for On/Off applications. Performance may be affected in throttling applications.

Standard Relay:

At 1.4 bar (20 psig) supply pressure: Less than 0.38 normal m³/hr (14 scfh)
At 5.5 bar (80 psig) supply pressure: Less than 1.3 normal m³/hr (49 scfh)

Maximum Output Capacity⁽³⁾⁽⁴⁾

At 1.4 bar (20 psig) supply pressure: 10.0 normal m³/hr (375 scfh)
At 5.5 bar (80 psig) supply pressure: 29.5 normal m³/hr (1100 scfh)

–continued–

DVC6000 SIS Specifications (continued)

Independent Linearity⁽⁵⁾

±0.50% of output span

Electromagnetic Interference (EMI)

Meets EN 61326-1 (First Edition)

Immunity—Industrial locations per Table 2 of the EN 61326-1 standard. Performance is shown in table 1 below.

Emissions—Class A

ISM equipment rating: Group 1, Class A

Lightning and Surge Protection—The degree of immunity to lightning is specified as Surge immunity in table 1. For additional surge protection commercially available transient protection devices can be used.

IEC 61010 Compliance Requirements (Valve-Mounted Instruments Only)

Power Source: The loop current must be derived from a separated extra-low voltage (SELV) power source

Environmental Conditions: Installation Category I

Electrical Classification

Hazardous Area

CSA—Intrinsically Safe, Explosion-proof, Division 2, Dust Ignition-proof

FM—Intrinsically Safe, Explosion-proof, Non-incendive, Dust Ignition-proof

ATEX—Intrinsically Safe, Flameproof, Type n

IECEx—Intrinsically Safe, Flameproof, Type n

NEPSI—Intrinsically Safe, Flameproof

INMETRO—Intrinsically Safe, Flameproof, Type n

Electrical Housing

CSA—Type 4, IP66

FM—NEMA 4X

ATEX—IP66

IECEx—IP66

NEPSI—IP66

The Gas Certified DVC6000 SIS is FM, ATEX, IECEx, INMETRO, and CSA Single Seal

approved for use with natural gas as the supply medium (exida or non-certified only)

Refer to tables 2, 3, 4, 5, 6, and 7 for specific approval information

Auxiliary Terminal Contact: Nominal Electrical Rating 5 V, <1 mA; It is recommended that the switch be sealed or have gold plated contacts to avoid corrosion.

Other Classifications/Certifications

TIIS—Japan

KISCO—Korea Industrial Safety Corp.

GOST-R—Russian GOST-R

FSETAN—Russian – Federal Service of Technological, Ecological and Nuclear Inspectorate

Contact your Emerson Process Management sales office for classification/certification specific information

Connections

Supply Pressure: 1/4 NPT internal and integral pad for mounting 67CFR regulator

Output Pressure: 1/4 NPT internal

Tubing: 3/8-inch, recommended

Vent (pipe-away): 3/8 NPT internal

Electrical: 1/2 NPT internal conduit connection

Vibration Testing Method

Tested per ANSI/ISA-S75.13.01 Section 5.3.5. A resonant frequency search is performed on all three axes. The instrument is subjected to the ISA specified 1/2 hour endurance test at each major resonance, plus an additional two million cycles.

Humidity Limits

0 to 100% condensing relative humidity with minimal zero or span shifts

Input Impedance

The input impedance of the DVC6000 active electronic circuit is not purely resistive. For comparison to resistive load specifications, an equivalent impedance of 550 ohms may be used. This value corresponds to 11V @ 20 mA.

–continued–

DVC6000 SIS Specifications (continued)

Operating Ambient Temperature Limits⁽²⁾⁽⁶⁾

- 40 to 85°C (-40 to 185°F) for most approved valve-mounted instruments
- 60 to 125°C (-76 to 257°F) for remote-mounted feedback unit
- 52 to 85°C (-62 to 185°F) for valve-mounted instruments utilizing the Extreme Temperature option (fluorosilicone elastomers)

Construction Materials

- Housing, module base and terminal box:** ASTM B85 A03600 low copper aluminum alloy (standard)
- CF8M (cast 316 stainless steel) (optional for valve-mounted instruments only)
- Cover:** Thermoplastic polyester
- Elastomers**
Standard: Nitrile
Optional: Fluorosilicone

Stem/Shaft Travel

- Linear Actuators with rated travel between 6.35 mm (0.25 inch) and 102 mm (4.00 inch)
- Rotary Actuators with rated travel between 50 degrees and 180 degrees.

Mounting

Designed for direct actuator mounting or remote pipestand or wall mounting. Mounting the

instrument vertically, with the vent at the bottom of the assembly, or horizontally, with the vent pointing down, is recommended to allow drainage of moisture that may be introduced via the instrument air supply.

Weight

Valve-Mounted Instruments

- Aluminum:* 3.5 kg (7.7 lbs)
- Stainless steel:* 7.7 kg (17 lbs)

Remote-Mounted Instruments

- DVC6005 SIS Base Unit:* 4.1 kg (9 lbs)
- DVC6015 Feedback Unit:* 1.3 kg (2.9 lbs)
- DVC6025 Feedback Unit:* 1.4 kg (3.1 lbs)
- DVC6035 Feedback Unit:* 0.9 kg (2.0 lbs)

Options

- Supply and output pressure gauges or ■ Tire valves, ■ Integral mounted filter regulator, ■ Stainless steel housing, module base and terminal box (valve-mounted instruments only)⁽⁷⁾, ■ Standard Relay, ■ Extreme Temperature⁽⁷⁾, ■ Remote Mount⁽⁷⁾, ■ Beacon Indicator, ■ LCP100 local control panel, ■ Natural Gas Certified⁽⁷⁾, ■ Feedback Assembly PTFE Sleeve Protective Kit for aluminum units in saltwater or particulate environments

NOTE: Specialized instrument terms are defined in ANSI/ISA Standard 51.1 – Process Instrument Terminology.
 1. 3-conductor shielded cable, 22 AWG minimum wire size, is recommended for connection between base unit and feedback unit. Pneumatic tubing between base unit output connection and actuator has been tested to 15 meters (50 feet) maximum without performance degradation.
 2. The pressure/temperature limits in this document and any other applicable code or standard should not be exceeded.
 3. Normal m³/hour – Normal cubic meters per hour at 0°C and 1.01325 bar, absolute. Scfh – Standard cubic feet per hour at 60°F and 14.7 psia.
 4. Values at 1.4 bar (20 psig) based on a single-acting direct relay; values at 5.5 bar (80 psig) based on double-acting relay.
 5. Typical value. Not applicable for DVC6020 SIS digital valve controllers in long-stroke applications or remote-mounted DVC6005 SIS with long pneumatic tubing lengths.
 6. Temperature limits vary based on hazardous area approval.
 7. Natural Gas Certified, Stainless Steel, Remote Mount, and Extreme Temperature options are exida approved. TUV approval is in progress. Contact your Emerson Process Management sales office for specific approval information.

Table 1. EMC Summary Results for DVC6000 SIS—Immunity

Port	Phenomenon	Basic Standard	Test Level	Performance Criteria ⁽¹⁾	
				Point-to-Point Mode	Multi-drop Mode
Enclosure	Electrostatic discharge (ESD)	IEC 61000-4-2	4 kV contact 8 kV air	A ⁽²⁾	A
	Radiated EM field	IEC 61000-4-3	80 to 1000 MHz @ 10V/m with 1 kHz AM at 80% 1400 to 2000 MHz @ 3V/m with 1 kHz AM at 80% 2000 to 2700 MHz @ 1V/m with 1 kHz AM at 80%	A	A
	Rated power frequency magnetic field	IEC 61000-4-8	60 A/m at 50 Hz	A	A
I/O signal/control	Burst	IEC 61000-4-4	1 kV	A ⁽²⁾	A
	Surge	IEC 61000-4-5	1 kV (line to ground only, each)	A ⁽²⁾	A
	Conducted RF	IEC 61000-4-6	150 kHz to 80 MHz at 3 Vrms	A	A

1. A = No degradation during testing. B = Temporary degradation during testing, but is self-recovering.
 2. Excluding auxiliary switch function, which meets Performance Criteria B.

Table 2. Hazardous Area Classifications—CSA (Canada)

Certification Body	Type	Certification Obtained	Entity Rating		Temperature Code	Enclosure Rating
CSA	DVC60x0 DVC60x0S (x = 1,2,3)	Ex ia Intrinsically Safe Class I,II,III Division 1 GP A,B,C,D,E, F,G per drawing GE42818 T5 Natural Gas Approved	Vmax = 30 VDC Imax = 226 mA Ci = 5 nF Li = 0.55 mH		T5(Tamb ≤ 80°C)	Type 4X, IP66 Single Seal Device
		Explosion Proof Class I Division 1 GP B,C,D T6 Natural Gas Approved	---		T6(Tamb ≤ 80°C)	Type 4X, IP66 Single Seal Device
		Class I Division 2 GP A,B,C,D T6 Class II Division 1 GP E,F,G T6 Class II Division 2 GP F,G T6 Class III Natural Gas Approved	---		T6(Tamb ≤ 80°C)	Type 4X, IP66 Single Seal Device
	DVC6005	Ex ia Intrinsically Safe Class I,II,III Division 1 GP A,B,C,D, E,F,G per drawing GE42818 T5 Natural Gas Approved	Vmax = 30 VDC Imax = 226 mA Ci = 5 nF Li = 0.55 mH	Voc = 9.6 VDC Isc = 3.5 mA Ca = 3.6 uF La = 100 mH	T5(Tamb ≤ 80°C)	Type 4X, IP66 Single Seal Device
		Explosion Proof Class I Division 1 GP B,C,D T6 Natural Gas Approved	---		T6(Tamb ≤ 80°C)	Type 4X, IP66 Single Seal Device
		Class I Division 2 GP A,B,C,D T6 Class II Division 1 GP E,F,G T6 Class II Division 2 GP FG T6 Class III Natural Gas Approved	---		T6(Tamb ≤ 80°C)	Type 4X, IP66 Single Seal Device
	DVC60x5 (x = 1,2,3)	Ex ia Intrinsically Safe Class I,II,III Division 1 GP A,B,C,D, E,F,G per drawing GE42818	Vmax = 30 VDC Imax = 17.5 mA Ci = 0 uF Li = 0 mH		T4(Tamb ≤ 125°C) T5(Tamb ≤ 95°C) T6(Tamb ≤ 80°C)	Type 4X, IP66
		Explosion Proof Class I Division 1 GP B,C,D T6	---		T4(Tamb ≤ 125°C) T5(Tamb ≤ 95°C) T6(Tamb ≤ 80°C)	Type 4X, IP66
		Class I Division 2 GP A,B,C,D T6 Class II Division 1,2 GP E,F,G T6 Class III	---		T4(Tamb ≤ 125°C) T5(Tamb ≤ 95°C) T6(Tamb ≤ 80°C)	Type 4X, IP66

Product Bulletin

62.1:DVC6000 SIS
December 2010

DVC6000 SIS

Table 3. Hazardous Area Classifications—FM (United States)

Certification Body	Type	Certification Obtained	Entity Rating		Temperature Code	Enclosure Rating
FM	DVC60x0 DVC60x0S (x = 1,2,3)	Intrinsically Safe Class I,II,III Division 1 GP A,B,C,D, E,F,G per drawing GE42819 T5 Natural Gas Approved	Vmax = 30 VDC Imax = 226 mA Ci = 5 nF Li = 0.55 mH Pi = 1.4 W		T5(Tamb ≤ 80°C)	NEMA 4X
		Explosion Proof Class I Division 1 GP B,C,D T6 Natural Gas Approved	---		T6(Tamb ≤ 80°C)	NEMA 4X
		Class I Division 2 GP A,B,C,D T6 Class II Division 1 GP E,F,G T6 Class II Division 2 GP F,G T6 Class III Natural Gas Approved	---		T6(Tamb ≤ 80°C)	NEMA 4X
	DVC6005	Intrinsically Safe Class I,II,III Division 1 GP A,B,C,D,E, F,G per drawing GE42819 T5 Natural Gas Approved	Vmax = 30 VDC Imax = 226 mA Ci = 5 nF Li = 0.55 mH Pi = 1.4 W	Voc = 9.6 VDC Isc = 3.5 mA Ca = 3.6 uF La = 100 mH Po = 8.4 mW	T4(Tamb ≤ 125°C) T5(Tamb ≤ 95°C) T6(Tamb ≤ 80°C)	NEMA 4X
		Explosion Proof Class I Division 1 GP B,C,D T6 Natural Gas Approved	---		T6(Tamb ≤ 60°C)	NEMA 4X
		Class I Division 2 GP A,B,C,D T6 Class II Division 1 GP E,F,G T6 Class II Division 2 GP F,G T6 Class III Natural Gas Approved	---		T6(Tamb ≤ 60°C)	NEMA 4X
	DVC60x5 (x = 1,2,3)	Intrinsically Safe Class I,II,III Division 1 GP A,B,C,D, E,F,G per drawing GE42819	Vmax = 30 VDC Imax = 17.5 mA Ci = 0 nF Li = 0 mH Pi = 105 mW		T4(Tamb ≤ 125°C) T5(Tamb ≤ 95°C) T6(Tamb ≤ 80°C)	NEMA 4X
		Explosion Proof Class I Division 1 GP A,B,C,D	---		T4(Tamb ≤ 125°C) T5(Tamb ≤ 95°C) T6(Tamb ≤ 80°C)	NEMA 4X
		Class I Division 2 GP A,B,C,D Class II Division 1 GP E,F,G Class II Division 2 GP F,G	---		T4(Tamb ≤ 125°C) T5(Tamb ≤ 95°C) T6(Tamb ≤ 80°C)	NEMA 4X

Table 4. Hazardous Area Classifications—ATEX

Certificate	Type	Certification Obtained	Entity Rating		Temperature Code	Enclosure Rating
ATEX	DVC60x0 DVC60x0S (x = 1,2,3)	Ⓜ II 1 G & D Intrinsically Safe Gas Ex ia IIC T5/T6 Dust Ex iaD 20 T100°C (Tamb ≤ 80°C) Ex iaD 20 T85°C (Tamb ≤ 75°C) Natural Gas Approved	U _i = 30 VDC I _i = 226 mA C _i = 5 nF L _i = 0.55 mH P _i = 1.4 W		T5(Tamb ≤ 80°C) T6(Tamb ≤ 75°C)	IP66
		Ⓜ II 2 G & D Flameproof Gas Ex d IIC T5/T6 Dust Ex tD A21 IP66 T90°C (Tamb ≤ 85°C) Ex tD A21 IP66 T80°C (Tamb ≤ 75°C) Natural Gas Approved	---		T5(Tamb ≤ 85°C) T6(Tamb ≤ 75°C)	IP66
		Ⓜ II 3 G & D Type n Gas Ex nCnL IIC T5/T6 Dust Ex tD A22 IP66 T85°C (Tamb ≤ 80°C) Ex tD A22 IP66 T80°C (Tamb ≤ 75°C) Natural Gas Approved	---		T5(Tamb ≤ 80°C) T6(Tamb ≤ 75°C)	IP66
	DVC6005	Ⓜ II 1 G & D Intrinsically Safe Gas Ex ia IIC T5/T6 Dust Ex iaD 20 T100°C (Tamb ≤ 80°C) Ex iaD 20 T85°C (Tamb ≤ 75°C) Natural Gas Approved	U _i = 30 VDC I _i = 226 mA C _i = 5 nF L _i = 0.55 mH P _i = 1.4 mW	U _o = 9.6 VDC I _o = 3.5 mA C _o = 3.6 uF L _o = 100 mH P _o = 8.4 mW	T5(Tamb ≤ 80°C) T6(Tamb ≤ 75°C)	IP66
		Ⓜ II 2 G & D Flameproof Gas Ex d IIC T5/T6 Dust Ex tD A21 IP66 T90°C (Tamb ≤ 85°C) Ex tD A21 IP66 T80°C (Tamb ≤ 75°C) Natural Gas Approved	---		T5(Tamb ≤ 85°C) T6(Tamb ≤ 75°C)	IP66
		Ⓜ II 3 G & D Type n Gas Ex nCnL IIC T5/T6 Dust Ex tD A22 IP66 T85°C (Tamb ≤ 80°C) Ex tD A22 IP66 T80°C (Tamb ≤ 75°C) Natural Gas Approved	---		T5(Tamb ≤ 80°C) T6(Tamb ≤ 75°C)	IP66

-continued-

Table 4. Hazardous Area Classifications—ATEX (continued)

Certificate	Type	Certification Obtained	Entity Rating	Temperature Code	Enclosure Rating
ATEX	DVC60x5 (x = 1,2,3)	Ⓜ II 1 G & D Intrinsically Safe Gas Ex ia IIC T4/T5/T6 Dust Ex iaD 20 T135°C (Tamb ≤ 125°C) Ex iaD 20 T100°C (Tamb ≤ 95°C) Ex iaD 20 T85°C (Tamb ≤ 80°C)	Ui = 30 VDC Ii = 17.5 mA Ci = 0 uF Li = 0 mH Pi = 105 mW	T4(Tamb ≤ 125°C) T5(Tamb ≤ 95°C) T6(Tamb ≤ 80°C)	IP66
		Ⓜ II 2 G & D Flameproof Gas Ex d IIC T4/T5/T6 Dust Ex tD A21 IP66 T130°C (Tamb ≤ 125°C) Ex tD A21 IP66 T100°C (Tamb ≤ 95°C) Ex tD A22 IP66 T85°C (Tamb ≤ 80°C)	---	T4(Tamb ≤ 125°C) T5(Tamb ≤ 95°C) T6(Tamb ≤ 80°C)	IP66
		Ⓜ II 3 G & D Type n Gas Ex nA IIC T4/T5/T6 Dust Ex tD A22 IP66 T130°C (Tamb ≤ 125°C) Ex tD A22 IP66 T100°C (Tamb ≤ 95°C) Ex tD A22 IP66 T85°C (Tamb ≤ 80°C)	---	T4(Tamb ≤ 125°C) T5(Tamb ≤ 95°C) T6(Tamb ≤ 80°C)	IP66

Table 5. Hazardous Area Classifications—IECEX

Certificate	Type	Certification Obtained	Entity Rating		Temperature Code	Enclosure Rating
IECEX	DVC60x0 DVC60x0S (x = 1,2,3)	Intrinsically Safe Gas Ex ia IIC T5/T6 per drawing GE42990 Natural Gas Approved	Ui = 30 VDC Ii = 226 mA Ci = 5 nF Li = 0.55 mH Pi = 1.4 W		T5(Tamb ≤ 80°C) T6(Tamb ≤ 75°C)	IP66
		Flameproof Gas Ex d IIC T5/T6 Natural Gas Approved	---		T5(Tamb ≤ 80°C) T6(Tamb ≤ 75°C)	IP66
		Type n Gas Ex nC IIC T5/T6 Natural Gas Approved	---		T5(Tamb ≤ 80°C) T6(Tamb ≤ 75°C)	IP66
	DVC6005	Intrinsically Safe Gas Ex ia IIC T5/T6 per drawing GE42990 Natural Gas Approved	Ui = 30 VDC Ii = 226 mA Ci = 5 nF Li = 0.55 mH Pi = 1.4 W	Uo = 9.6 VDC Io = 3.5 mA Co = 3.6 uF Lo = 100 mH Po = 8.4 mW	T5(Tamb ≤ 80°C) T6(Tamb ≤ 75°C)	IP66
		Flameproof Gas Ex d IIC T5/T6 Natural Gas Approved	---		T5(Tamb ≤ 80°C) T6(Tamb ≤ 75°C)	IP66
		Type n Gas Ex nC IIC T5/T6 Natural Gas Approved	---		T5(Tamb ≤ 80°C) T6(Tamb ≤ 75°C)	IP66
	DVC60x5 (x = 1,2,3)	Intrinsically Safe Gas Ex ia IIC T4/T5/T6	Ui = 30 VDC Ii = 17.5 mA Ci = 0 uF Li = 0 mH Pi = 105 mW		T4(Tamb ≤ 125°C) T5(Tamb ≤ 95°C) T6(Tamb ≤ 80°C)	IP66
		Flameproof Gas Ex d IIC T4/T5/T6	---		T4(Tamb ≤ 125°C) T5(Tamb ≤ 95°C) T6(Tamb ≤ 80°C)	IP66
		Type n Gas Ex nA IIC T4/T5/T6	---		T4(Tamb ≤ 125°C) T5(Tamb ≤ 95°C) T6(Tamb ≤ 80°C)	IP66

Table 6. Hazardous Area Classifications—NEPSI

Certificate	Type	Certification Obtained	Entity Rating		Temperature Code	Enclosure Rating
NEPSI	DVC60x0 DVC60x0S (x = 1,2,3)	Intrinsically Safe Gas Ex ia IIC T5/T6 Dust DIP A21 T5	U _i = 30 V I _i = 226 mA C _i = 5 nF L _i = 0.55 mH P _i = 1.4 W		T5(Tamb ≤ 80°C) T6(Tamb ≤ 75°C)	IP66
		Flameproof Gas Ex d IIC T5/T6 Dust DIP A21 T5	---		T5(Tamb ≤ 80°C) T6(Tamb ≤ 75°C)	IP66
	DVC6005	Intrinsically Safe Gas Ex ia IIC T5/T6 Dust DIP A21 T5	U _i = 30 VDC I _i = 226 mA C _i = 5 nF L _i = 0.55 mH P _i = 1.4 W	U _o = 9.6 VDC I _o = 3.5 mA C _o = 3.6 uF L _o = 100 mH P _o = 8.4 mW	T5(Tamb ≤ 80°C) T6(Tamb ≤ 75°C)	IP66
		Flameproof Gas Ex d IIC T5/T6 Dust DIP A21 T5	---		T5(Tamb ≤ 80°C) T6(Tamb ≤ 75°C)	IP66
	DVC60x5 (x = 1,2,3)	Intrinsically Safe Gas Ex ia IIC T4/T5/T6	---		T4(Tamb ≤ 125°C) T5(Tamb ≤ 95°C) T6(Tamb ≤ 80°C)	IP66
		Flameproof Gas Ex d IIC T4/T5/T6	---		T4(Tamb ≤ 125°C) T5(Tamb ≤ 95°C) T6(Tamb ≤ 80°C)	IP66

Table 7. Hazardous Area Classifications—INMETRO

Certificate	Type	Certification Obtained	Entity Rating		Temperature Code	Enclosure Rating
INMETRO	DVC60x0 DVC60x0S (x = 1,2,3)	Intrinsically Safe Gas BR-Ex ia IIC T5/T6 per drawing GE42990 Natural Gas Approved	Ui = 30 VDC Ii = 226 mA Ci = 5 nF Li = 0.55 mH Pi = 1.4 W		T5(Tamb ≤ 80°C) T6(Tamb ≤ 75°C)	IP66
		Flameproof Gas BR-Ex d IIC T5/T6 Natural Gas Approved	---		T5(Tamb ≤ 80°C) T6(Tamb ≤ 75°C)	IP66
		Type n Gas BR-Ex nC IIC T5/T6 Natural Gas Approved	---		T5(Tamb ≤ 80°C) T6(Tamb ≤ 75°C)	IP66
	DVC6005	Intrinsically Safe Gas BR-Ex ia IIC T5/T6 per drawing GE42990 Natural Gas Approved	Ui = 30 VDC Ii = 226 mA Ci = 5 nF Li = 0.55 mH Pi = 1.4 W	Uo = 9.6 VDC Io = 3.5 mA Co = 3.6 uF Lo = 100 mH Po = 8.4 mW	T5(Tamb ≤ 80°C) T6(Tamb ≤ 75°C)	IP66
		Flameproof Gas BR-Ex d IIC T5/T6 Natural Gas Approved	---		T5(Tamb ≤ 80°C) T6(Tamb ≤ 75°C)	IP66
		Type n Gas BR-Ex nC IIC T5/T6 Natural Gas Approved	---		T5(Tamb ≤ 80°C) T6(Tamb ≤ 75°C)	IP66
	DVC60x5 (x = 1,2,3)	Intrinsically Safe Gas BR-Ex ia IIC T4/T5/T6	Ui = 30 VDC Ii = 17.5 mA Ci = 0 uF Li = 0 mH Pi = 105 mW		T4(Tamb ≤ 125°C) T5(Tamb ≤ 95°C) T6(Tamb ≤ 80°C)	IP66
		Flameproof Gas BR-Ex d IIC T4/T5/T6	---		T4(Tamb ≤ 125°C) T5(Tamb ≤ 95°C) T6(Tamb ≤ 80°C)	IP66
		Type n Gas BR-Ex nA IIC T4/T5/T6	---		T4(Tamb ≤ 125°C) T5(Tamb ≤ 95°C) T6(Tamb ≤ 80°C)	IP66

Additional System Components: Specifications, Requirements, and Functionality

**LC340 SIS Line Conditioner, figure 20
(Required for 2-wire system installations with solenoid valve)**

Input Current⁽¹⁾: equal to load requirements, not to exceed 100 mA

Input Voltage⁽¹⁾: load voltage + (30 ohms x load current); nominally 24 volts DC. See figure 19.

Ambient Operating Temperature⁽²⁾: -40 to 85°C (-40 to 185°F)

Ambient Relative Humidity: 5-95%

Electrical Classification: Per IEC 61326-1
Complies with test requirements for I/O
Signal/Control ports on equipment intended for use in industrial environments

Mounting: standard 35 mm DIN rail

Installation Environment: Marshalling cabinet, I/O cabinet, or junction box

Dimensions: 75 mm (3 inches) long by 12.5 mm (0.5 inches) wide by 60 mm (2.4 inches) deep

Solenoid Valve

•ASCO™ EF8316G303 (3/8 NPT), EF8316G304 (1/2 NPT), or equivalent low-power solenoid valve⁽³⁾ for a 2-wire system

•ASCO EFX8553G305 103594 (1/2 NPT), EFX8551G305 103594 (1/4 NPT), or equivalent low power solenoid valve⁽⁴⁾ for a 2-wire system

•ASCO EF8316G3 (3/8 NPT), EF8316G4 (1/2 NPT), or equivalent solenoid valve⁽³⁾ for a 4-wire system

•ASCO EFX8553G305 103594 (1/2 NPT), EFX8551G305 103594 (1/4 NPT), or equivalent solenoid valve⁽⁴⁾ for a 4-wire system

Orifice Size: 5/8-inch

Operating Voltage: 24 VDC

Body Material: brass

Body and orifice selection may vary with actuator type and size, type of media, etc. Solenoid model number will change if size and body material or electrical ratings change.

LCP100 Local Control Panel

Power Options (switch selectable)

■ External: 24 VDC +/- 10% @ 50 mA maximum continuous current (100 mA maximum inrush)

■ Loop: 8-20 mA (LCP100 and DVC6000 SIS combined)

Temperature Limits⁽²⁾: -40 to 65°C (-40 to 149°F)

Maximum distance between LCP100 and DVC6000 digital valve controller: Cable length is limited by maximum cable capacitance of 18000 pF. Typical 56 meters (185 feet) with 18 AWG shielded Audio, Control and Instrumentation Cable

Electrical Classification

CSA— Ex em IIC T4
Suitable for Zone 1 and Zone 2 locations

FM— Ex em IIC T4
Suitable for Zone 1 and Zone 2 locations (pending agency approval)⁽⁵⁾

ATEX— Ex e mb [ib] IIC T4 Gb
Suitable for Zone 1 and Zone 2 locations

IECEX— Ex e mb [ib] IIC T4
Suitable for Zone 1 and Zone 2 locations

Refer to table 9 for specific approval information.

Electrical Housing: IP66

Electromagnetic Interference (EMI) Tested per IEC 61326 (2002). Complies with European EMC Directive. Meets emission limits for class A equipment (industrial locations). Meets immunity requirements for industrial locations (Table A.1 in the IEC specification document). Immunity performance is shown in table 8.

Connections Conduit: ■ 3/4 NPT or ■ M20

Wiring: 14 to 26 AWG

Electrical Installation: Wires are polarity sensitive

Compatibility: Requires DVC6000 SIS with Firmware revision 7 or later

Installation Orientation: Wiring entrance must be pointed down for self-draining

(continued)

Additional System Components: Specifications, Requirements, and Functionality

LCP100 Local Control Panel (continued)

Push buttons: Protected with lockable covers

Dimensions: 253.1 mm (10 inches) long by 109.5 mm (4.3 inches) wide by 127.8 mm (5 inches) deep. See figure 21.

Approximate Weight: 2.2 kg (4.9 lbs)

Lights

Green: Solid when the valve is at its normal operating position, and loop current is normal. Flashing when the valve is not at its normal operating position, and loop current is normal.

Red: Solid when the valve is at its Fail Safe State and loop current is tripped. Flashing when valve is not at its Fail Safe State and loop current is tripped.

Amber (Ready-to-Reset): Solid when the valve is latched in the trip position, and loop current is normal.

Buttons

Green:

- After an emergency demand— commands the valve to its normal position only after control current is restored (manual reset).
- During a test— abort test

Red: Always commands the valve to its Fail Safe State regardless of the control current.

Black: Press and hold for 3 to 10 seconds. Commands the configured partial stroke test. Can be overridden by the Close button, Open button, or Emergency Demand.

- During a test— abort test

1. The line conditioner requires no power to operate; its input requirements are driven entirely by its output load requirements.
2. The pressure/temperature limits in this document and any other applicable code or standard should not be exceeded.
3. The use of external piloting requires the pilot pressure to be at least 15 psig higher than the main line pressure.
4. ASCO EFX8553G305 103594 or EFX8551G305 103594 low-powered 24VDC solenoid valves with aluminum bodies can be used where the application requires zero differential pressure and when the solenoid valve exhaust port is connected to another solenoid valve used as a selector or diverter.
5. Contact your Emerson Process Management sales office for the status of pending agency approvals.

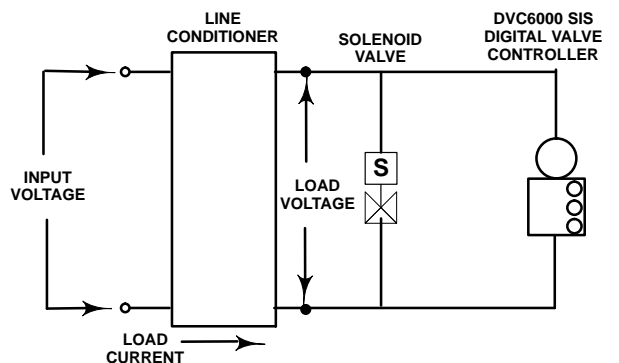

$$\text{INPUT VOLTAGE} = \text{LOAD VOLTAGE} + \text{LINE CONDITIONER VOLTAGE DROP}$$

$$\text{LINE CONDITIONER VOLTAGE DROP} = 30 \text{ OHMS} \times \text{LOAD CURRENT}$$

CALCULATION EXAMPLE:

CALCULATING LOAD CURRENT

FOR THE SOLENOID VALVE,
ASSUME REQUIRES MINIMUM 42 mA AT 22 VOLTS DC TO PULL-IN
(FROM SOLENOID VALVE SPECIFICATIONS)

FOR THE DIGITAL VALVE CONTROLLER,
WHEN OPERATING IN MULTI-DROP, REQUIRES 8 mA
(FROM DIGITAL VALVE CONTROLLER SPECIFICATIONS)

$$\text{LOAD CURRENT} = 42 + 8 = 50 \text{ mA}$$

$$\text{LINE CONDITIONER VOLTAGE DROP} = 30 \text{ OHMS} \times .050 \text{ AMPS} = 1.5 \text{ VOLTS}$$

$$\text{INPUT VOLTAGE} = 22 \text{ VOLTS} + 1.5 \text{ VOLTS} = 23.5 \text{ VOLTS DC}$$

E0853

Figure 19. Determining Line Conditioner Input Voltage



Figure 20. Fisher LC340 Line Conditioner

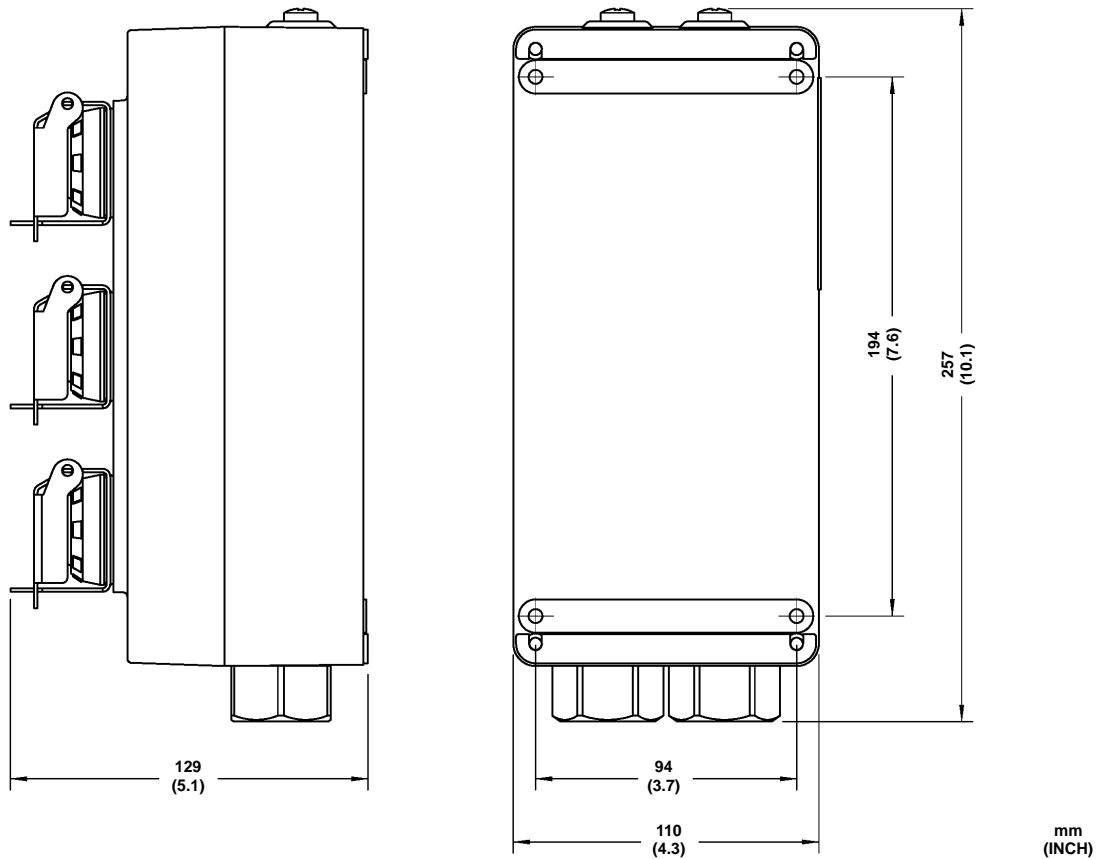

Figure 21. Fisher LCP100 Dimensions

Table 8. Electromagnetic Immunity Performance for Fisher LCP100

Port	Phenomenon	Basic Standard	Test Level	Performance Criteria ⁽¹⁾
Enclosure	Electrostatic discharge (ESD)	IEC 61000-4-2	± 4 kV contact ± 8 kV air	A
	Radiated EM field	IEC 61000-4-3	80 to 1000 MHz @ 10V/m with 1 kHz AM at 80% 1400 to 2000 MHz @ 3V/m with 1 kHz AM at 80% 2000 to 2700 MHz @ 1V/m with 1 kHz AM at 80%	A
I/O signal/control	Burst (fast transients)	IEC 61000-4-4	± 1 kV, I/O lines ± 2 kV, DC power lines	A
	Surge	IEC 61000-4-5	± 1 kV, I/O lines ± 2 kV, DC power lines)	A
	Conducted RF	IEC 61000-4-6	150 kHz to 80 MHz at 3 Vrms with 1 kHz AM at 80%	A

Specification limit = ±1% of span
1. A = No degradation during testing. B = Temporary degradation during testing, but is self-recovering.

Table 9. Hazardous Area Classifications for Fisher LCP100—CSA (Canada)

Certification Body	Certification Obtained	Entity Rating	Temperature Code	Enclosure Rating
CSA	Zone Ex em IIC T4	---	T4 (Tamb ≤ 65°C)	IP66

Table 10. Hazardous Area Classifications for Fisher LCP100—ATEX / IECEx

Certification	Certification Obtained	Entity Rating	Temperature Code	Enclosure Rating
ATEX / IECEx	Zone Ex e mb [ib] IIC T4 Gb	---	T4 (Tamb ≤ 65°C)	IP66

Note

Neither Emerson, Emerson Process Management, nor any of their affiliated entities assume responsibility for the selection, use, or maintenance of any product. Responsibility for the selection, use, and maintenance of any product remains with the purchaser and end user.

Fisher, FIELDVUE, ValveLink, DeltaV SIS, DeltaV, SIL-PAC, Bettis, El-O-Matic, Hytork, and FieldQ are marks owned by one of the companies in the Emerson Process Management business division of Emerson Electric Co. Emerson Process Management, Emerson, and the Emerson logo are trademarks and service marks of Emerson Electric Co. ASCO is a mark owned one of the companies in the Emerson Industrial Automation business division of Emerson Electric Co. HART is a mark owned by the HART Communication Foundation. All other marks are the property of their respective owners.

The contents of this publication are presented for informational purposes only, and while every effort has been made to ensure their accuracy, they are not to be construed as warranties or guarantees, express or implied, regarding the products or services described herein or their use or applicability. All sales are governed by our terms and conditions, which are available upon request. We reserve the right to modify or improve the designs or specifications of such products at any time without notice. Neither Emerson, Emerson Process Management, nor any of their affiliated entities assumes responsibility for the selection, use or maintenance of any product. Responsibility for proper selection, use, and maintenance of any product remains solely with the purchaser and end user.

Emerson Process Management

Marshalltown, Iowa 50158 USA

Sorocaba, 18087 Brazil

Chatham, Kent ME4 4QZ UK

Dubai, United Arab Emirates

Singapore 128461 Singapore

www.Fisher.com

