

Fisher® 2052 Diaphragm Rotary Actuator

Fisher 2052 spring-and-diaphragm rotary actuators (see figures 1 and 2) are used on rotary-shaft valve bodies for throttling or on-off applications. The 2052 may be used for throttling service with a positioner, or it may be used for on-off service without a positioner. The 2052 has an ISO 5211 mating interface that allows installation to non-Fisher valves. Refer to separate bulletins for valve and positioner information.

Contents

2052 Actuator Specifications and Materials of Construction	2
Features	2
Options	3
Tables	
Actuator and Shaft Size	
Availability	5
Torque versus Actuator Size	5
Pressure Connections	5
Dimensions	6
Mounting Style	10



W9425

Figure 1. Fisher Control-Disk™ Valve with 2052 Actuator and DVC6000 Digital Valve Controller



2052 Actuator Specifications and Materials of Construction

See tables 1 and 2.

Table 1. Fisher 2052 Actuator Specifications

Specifications	
Actuator Mounting Connections	Splined shaft connection, ISO 5211 actuator-to-bracket connection Size 1: F07, Size 2: F10, Size 3: F14
Actuator Sizes	See table 3
Pressure Connection	See table 4
Operating Pressure ⁽¹⁾	See table 5
Torque Output	See table 5 Torque varies no more than 10 percent between PDTO (push-down-to-open) and PDTC (push-down-to-close)
Actuator Temperature Capabilities ⁽¹⁾	-45 to 80°C (-50 to 176°F)
Operation	Field reversible between PDTC and PDTO; right- and left-hand mounting, any angle of orientation
Weight	Size 1: 22.2 kg (49 lb) Size 2: 45.4 kg (100 lb) Size 3: 87.5 kg (193 lb)
Controller/Positioners Available	DVC2000, DVC6000, 3620, 4190, 4150, 4160, C1
Accessories Available	846, 646, 2625, and 67C Series, switches, i2P-100, VBL, DXP, GO®
Handwheel	Top-mounted handwheel: Optional on Size 1 and 2 actuators only Declutchable handwheel: Optional on Size 1, 2, and 3 actuators
Operational Lockout	Available for customer-supplied padlock to lock the actuator in the spring-fail position

1. The pressure/temperature limits in this bulletin and any applicable standard or code limitation for valve should not be exceeded.

Table 2. Materials (Other Actuator Components)

Component	Material
Upper Casing	Steel
Housing	Cast Iron
Diaphragm	Nitrile and nylon standard
Lever	Ductile iron
Diaphragm Plate	Cast iron

Features

- **Compact design, smaller actuators—**

Ensures reduced valve/actuator envelope dimensions leading to greater mounting versatility for both skids and smaller process plants, where space is at a premium.

- **Compatible with DVC2000 and DVC6000 controllers and 3620 positioner—**

The new actuator allows linkage-less feedback, via a contact-less magnetic array, from the lever to the end-mounted DVC2000. The DVC6000 and 3620

are side-mounted, with feedback through the cam and feedback arm.

- **Clamped lever to reduce lost motion—** The clamping of the lever onto a splined valve shaft, coupled with the single pivot linkage, reduces lost motion between the actuator and the valve. The typical cumulative deadband for a Fisher rotary control valve assembly results in 0.5% or less variability.

- **No bench set required—** The new nested spring design requires no bench set. This also simplifies the actuator selection process, see table 3.

Features (continued)

- **ISO 5211 mounting with optional insert**— The actuator can now be mounted directly onto non-spline shafts, such as Square and Double D. This allows the actuator, with its enhanced control, to mount on a wider range of valves conforming to ISO 5211.
- **Adjustable travel stops standard with optional lockout feature**— Provides the ability to adjust or change the travel range without removing the actuator or the addition of extra parts. The optional lockout feature locks the lever in the spring-fail position.
- **Fail-safe mechanism contains no aluminum**— All parts (steel, cast iron, and ductile iron) in the fail-safe mechanism ensure the actuator will maintain safety integrity in the event of a fire.
- **Powder paint as standard**— The Emerson Process Management™ powder paint finish offers an excellent corrosion-resistant finish to all external steel and cast iron parts.
- **NAMUR VDE/VDI 3845 for accessory mounting**— Meeting the global standard ensures compatibility for most accessories, enabling quick and easy mounting.
- **Field reversible, right- or left-hand mounting**— The actuator/valve assembly action can be converted from push-down-to-open to push-down-to-close, or vice-versa, without additional parts.
- **Declutchable and top-mounted handwheels**— Available (except top-mounted not available for size 3 actuator).

Options

Top-Mounted Handwheel: For infrequent use as a manual actuator or for use as an adjustable up travel stop (see figure 3). For repeated or daily manual operation, the unit should be equipped with a declutchable handwheel actuator.

Declutchable Handwheel Actuator: A side-mounted manual actuator can be used to provide on-site control and to provide override capabilities. See bulletin 61.8:1078 for handwheel actuator specifications.

Limit Switches: ■ Micro-Switch or NAMCO switches for one or two single-pole, double-throw contacts, or ■ GO proximity switches for one or two single-pole, double-throw contacts are available. See separate bulletins for limit switch information.

Position Indicating Switch: TopWorx® DXP M21GNEB switch for one through six single pole, double throw switch contacts are available. See separate bulletin for position indicating switch information.

Positioner: For precise positioning of the valve disk or ball, the actuator should be equipped with a positioner. For additional information, contact your Emerson Process Management sales office with complete service conditions.

Actuator Locking Mechanism: An actuator locking mechanism is available, which can be used to keep the actuator in a locked position (the same as the spring-fail position) during maintenance. The padlock is customer supplied.

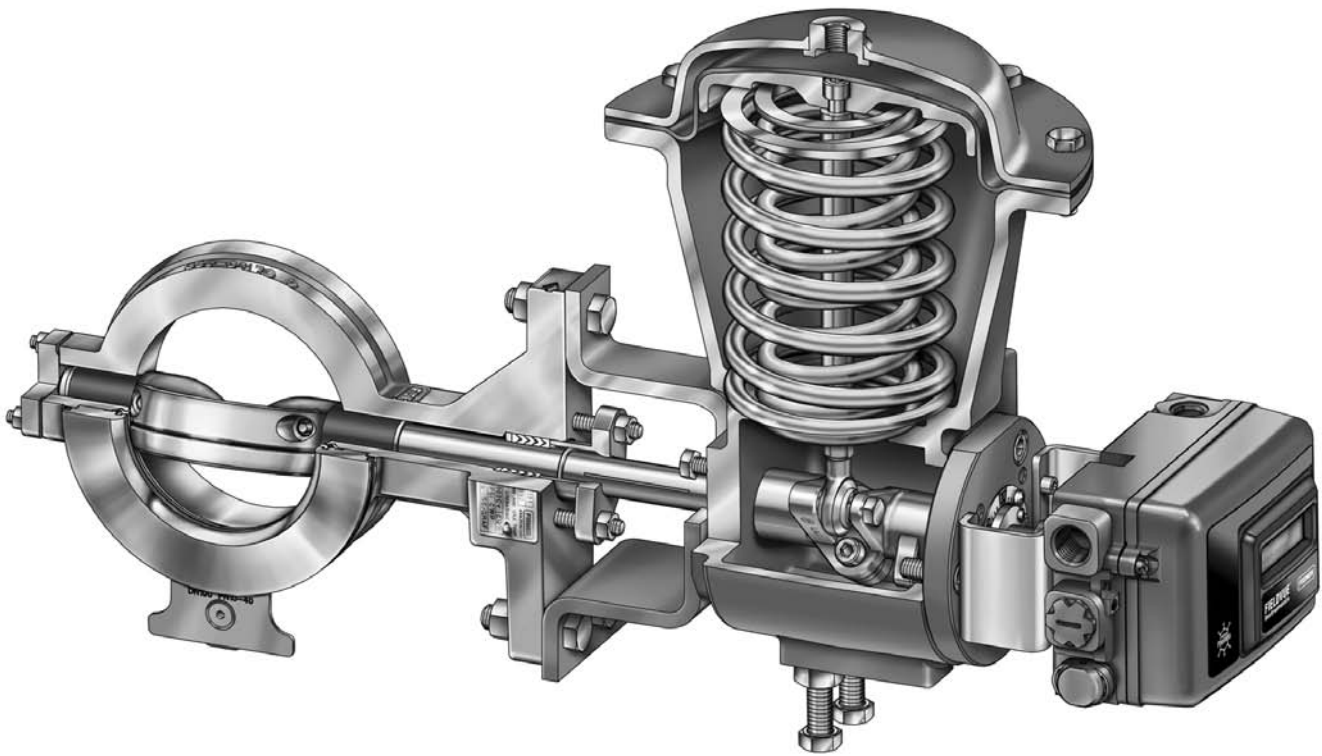

W9421-1

Figure 2. Fisher 2052 Assembly



W9484

Figure 3. Top-Mounted Handwheel

Table 3. Actuator and Shaft Size Availability

SHAFT SIZE		ACTUATOR SIZE		
mm	Inches	1	2	3
12.7	1/2	X		
15.9	5/8	X	X	
19.1	3/4	X	X	X
25.4	1		X	X
31.8	1-1/4		X	X
38.1	1-1/2			X
44.5	1-3/4			X
50.8	2			X

Table 4. Pressure Connections

ACTUATOR SIZE	PRESSURE CONNECTION			
	1/4 NPT	1/2 NPT	3/4 NPT	G 1/4
1	standard	optional		optional
2	standard	optional		optional
3		standard	optional	

Table 5. Torque versus Actuator Size

ACTUATOR SIZE	OPERATING PRESSURE			
	A 2-3 bar (29-43.5 psi)		B 4-5 bar (58-72.5 psi)	
	N•m	lbf•in	N•m	lbf•in
1	25.8	228	51.5	456
2	106	935	211	1870
3	311	2752	622	5504

Table 6. Dimensions

ACTUATOR SIZE	C		E		F		H		P		Y	
	mm	Inches	mm	Inches	mm	Inches	mm	Inches	mm	Inches	mm	Inches
1	245	9.65	267	10.51	29	1.14	103	4.06	107	4.21	71	2.80
2	350	13.78	424	16.69	49	1.93	187	7.36	170	6.69	84.5	3.33
3	496	19.53	592	23.31	64	2.52	244	9.61	185	7.28	92	3.62

Table 7. Actuator / Valve Body Mounting Dimensions

VALVE SHAFT DIAMETER		FIGURE 7 REFERENCE	T		U		W	
mm	Inches		mm	Inches	mm	Inches	mm	Inches
Style F Mounting: Control-Disk, Vee-Ball, 8532, 8510B, 8560, and 8580 Eccentric Disk Valves								
12.7 - 15.9	1/2 - 5/8	A	117	4.62	---	---	14.2	0.56
19.1 - 25.4	3/4 - 1	B	152	6.00	32	1.25	14.2	0.56
31.8 - 38.1	1-1/4 - 1-1/2	B	235	9.25	46	1.81	17.5	0.69
44.5 - 50.8	1-3/4 - 2	B	273	10.75	51	2.00	20.6	0.81
Style G Mounting: 9500 Series Valves								
12.7	1/2	A	117	4.62	---	---	11.0	0.44
15.9 - 25.4	5/8 - 1	B	146	5.75	32	1.25	11.0	0.44
31.8 - 38.1	1-1/4 - 1-1/2	B	210	8.25	51	2.00	17.5	0.69

Table 8. Actuator / Valve Body Mounting Dimensions

VALVE SHAFT DIAMETER		V					
mm	Inches	Size 1		Size 2		Size 3	
		mm	Inches	mm	Inches	mm	Inches
12.7	1/2	135	5.3				
15.9	5/8	135	5.3	148.5	5.8		
19.1	3/4	158	6.2	171.5	6.8	179	7.0
25.4	1			171.5	6.8	179	7.0
31.8	1-1/4			169.5	6.7	177	7.0
38.1	1-1/2					177	7.0
44.5	1-3/4					316	12.4
50.8	2					316	12.4

Table 9. Actuator / Valve Body Mounting Dimensions

ACTUATOR SIZE	Hc		Jc	
	mm	Inches	mm	Inches
1	207	8.1	171	6.7
2	289	11.4	305	12.0

Table 11. ISO 5211 Mounting Information

ACTUATOR SIZE	F SIZE	A	B
		mm	mm
1	F07	70	M8
2	F10	102	M10
3	F14	140	M16

Table 10. NAMUR Instrument Mounting Dimensions

ACTUATOR SIZE	J	K	L	M
	mm	mm	mm	mm
1	80	30	30.4	35
2	130	30	48.34	55
3	130	30	65	75

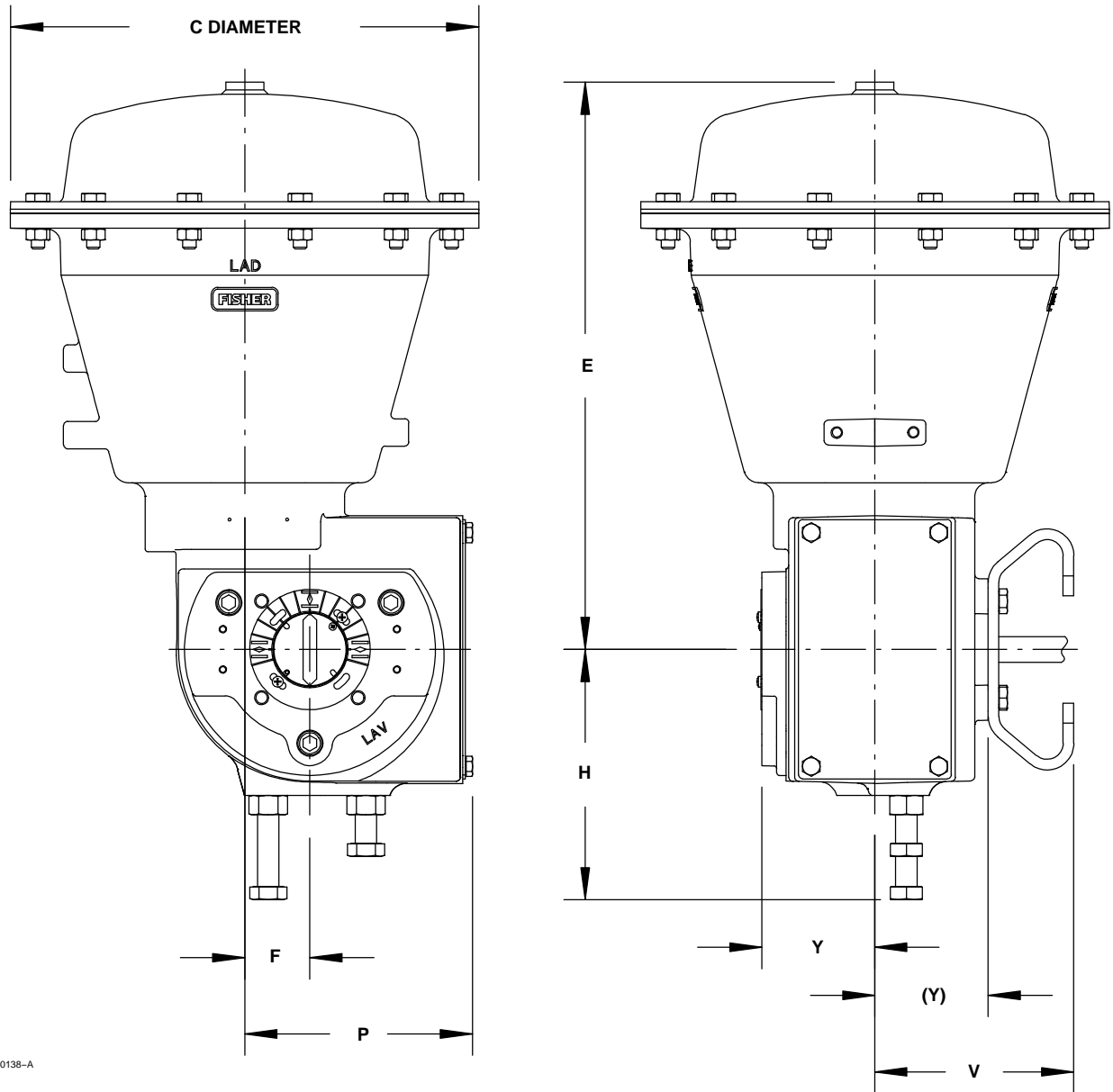

GG00138-A

Figure 4. Dimensions (also see tables 6, 7, and 8)

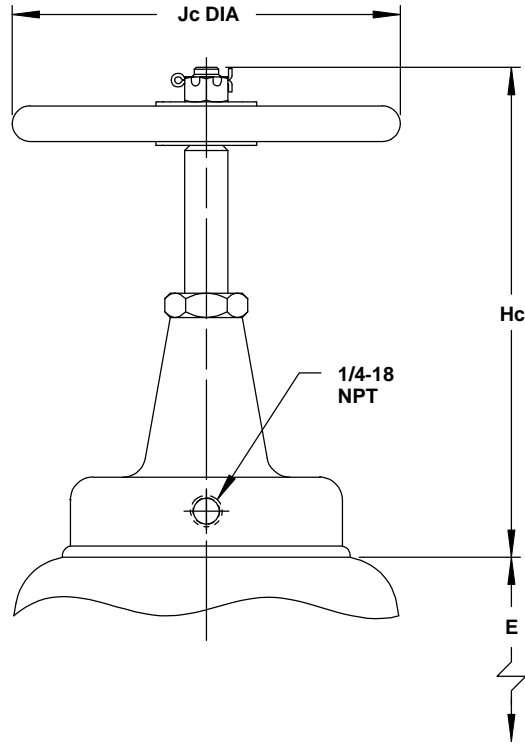

GE38370_1

Figure 5. Handwheel Dimensions (also see tables 6 and 9)

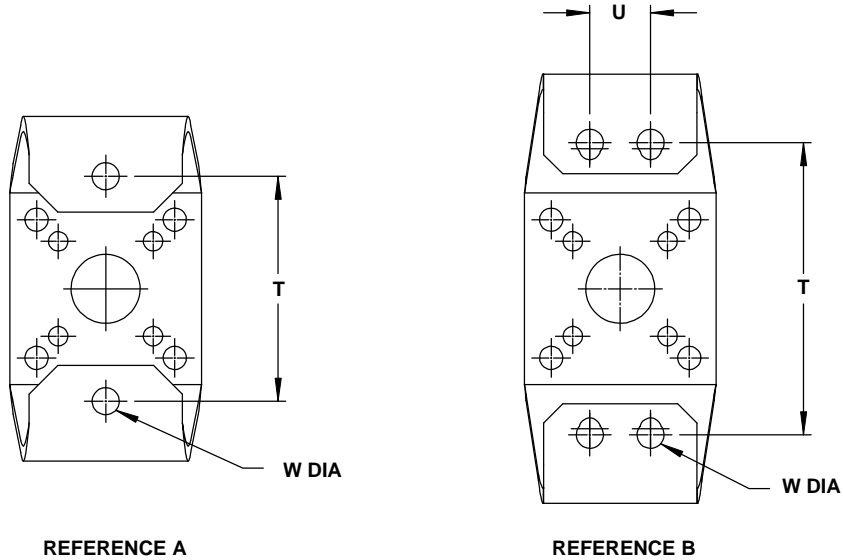

GE38375_1

Figure 6. Mounting Yokes Dimensions (also see table 7)

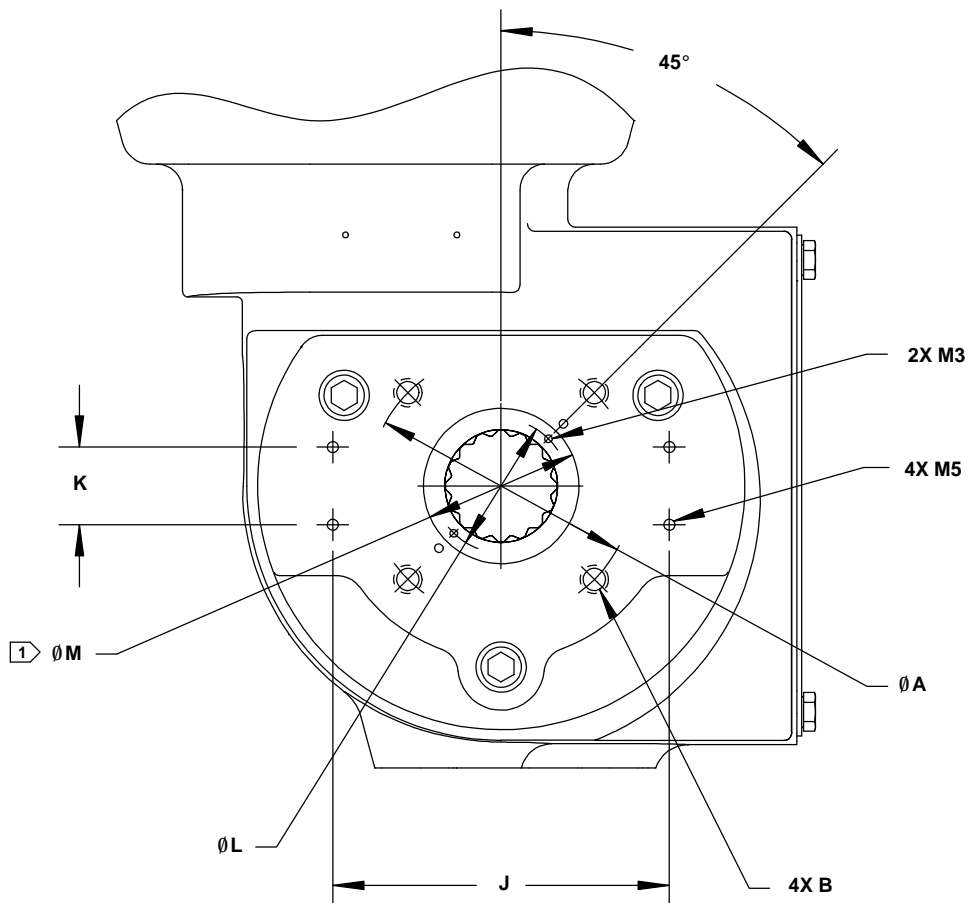

GG06029_B

1 M IS THE OUTSIDE DIAMETER OF THE LEVER HUB

Figure 7. NAMUR Instrument Mounting Dimensions (also see tables 10 and 11)

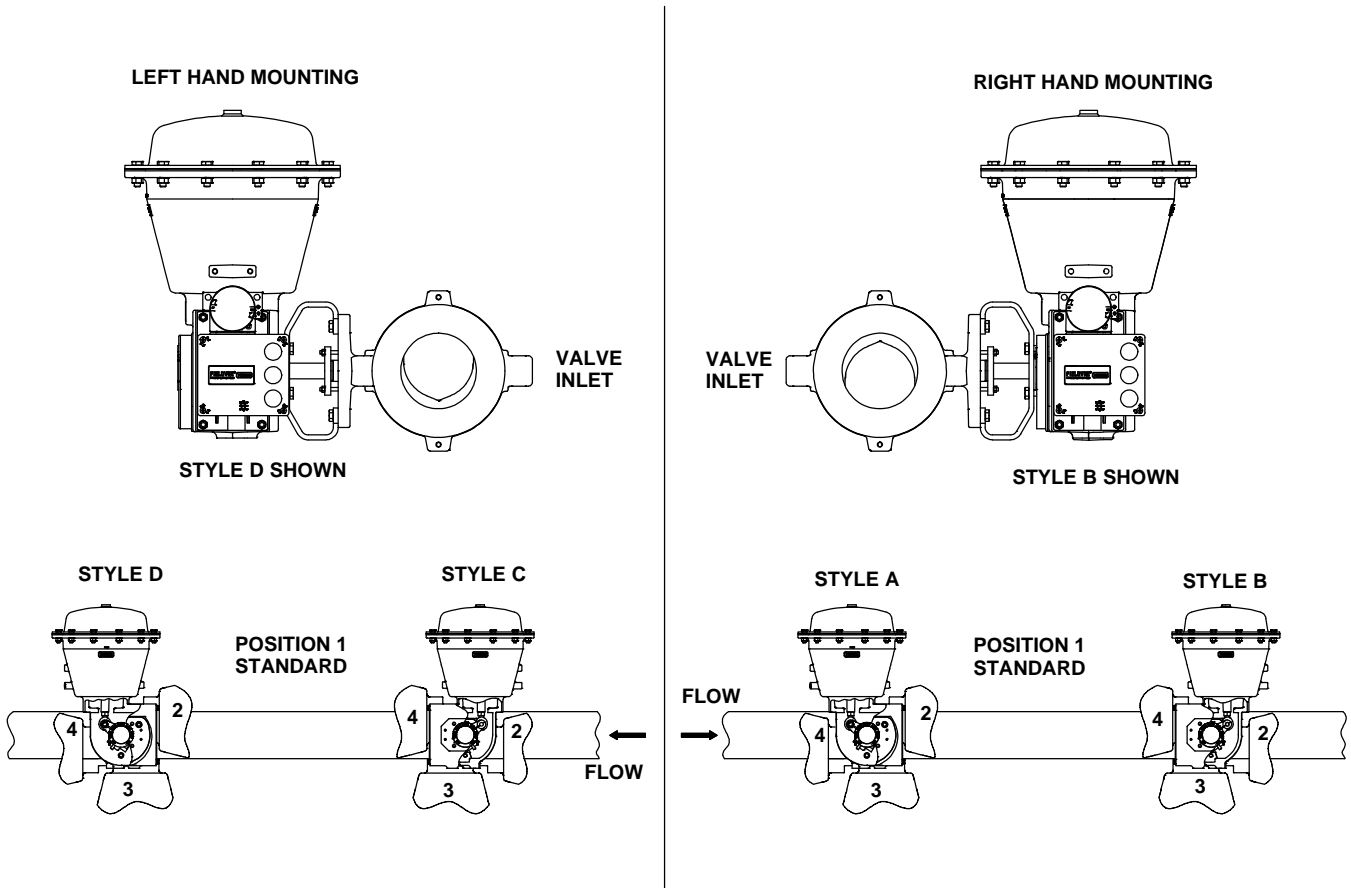

GE37285-B

Figure 8. Fisher 2052 Actuator Mounting Styles (also see table 12)

Table 12. Fisher 2052 Actuator Mounting Styles

MOUNTING (SEE FIGURE 8)	ACTION ⁽¹⁾	VALVE		
		V150, V200, V300 SERIES B ⁽²⁾	8510, 8510B, 8532, 8560, 8580, 9500, Control-Disk	V500, CV500
RIGHT-HAND	PDTC	A	B	A
	PDTO	B	A	B
LEFT-HAND		Ball on Bottom (standard)	Ball on Top (optional)	Ball on Bottom
	PDTC	D	C	D
	PDTO	C	D	C

1. PDTC = Push Down To Close. PDTO = Push Down To Open.
2. Includes NPS 14 and 16.

Note

Neither Emerson, Emerson Process Management, nor any of their affiliated entities assumes responsibility for the selection, use, or maintenance of any product. Responsibility for the selection, use, and maintenance of any product remains with the purchaser and end user.

Fisher, Control-Disk, GO, and TopWorx are marks owned by one of the companies in the Emerson Process Management business division of Emerson Electric Co. Emerson Process Management, Emerson, and the Emerson logo are trademarks and service marks of Emerson Electric Co. All other marks are the property of their respective owners.

The contents of this publication are presented for informational purposes only, and while every effort has been made to ensure their accuracy, they are not to be construed as warranties or guarantees, express or implied, regarding the products or services described herein or their use or applicability. All sales are governed by our terms and conditions, which are available upon request. We reserve the right to modify or improve the designs or specifications of such products at any time without notice. Neither Emerson, Emerson Process Management, nor any of their affiliated entities assumes responsibility for the selection, use or maintenance of any product. Responsibility for proper selection, use, and maintenance of any product remains solely with the purchaser and end user.

Emerson Process Management

Marshalltown, Iowa 50158 USA

Sorocaba, 18087 Brazil

Chatham, Kent ME4 4QZ UK

Dubai, United Arab Emirates

Singapore 128461 Singapore

www.Fisher.com

