

Fisher® POSI-SEAL™ A81 Rotary Valve

The Fisher POSI-SEAL A81 rotary valve with FieldQ™ rack-and-pinion actuator offers automated on-off, quarter-turn performance. It is available in spring-return and double-acting piston designs.

The valve body meets PN 10 through PN 40, CL150, and CL300 ratings. Face-to-face dimensions meet EN 558, API 609, and MSS-SP68 standards. Line centering clips provide for versatility to mount and align the same wafer style valve body in different piping configurations (ASME and EN ratings).

The A81 rotary valve features an eccentrically-mounted disk with either soft or metal seal, providing capability for enhanced shutoff. The interchangeable sealing technology allows for the same valve body to accept both soft and metal seals.

The actuator sizing and selection process is improved by simply reading a table for information.



W9479

A81 Features

- **Quarter-turn performance**— The valve has a square shaft-to-actuator connection and offers automated on-off, quarter-turn performance.
- **Global Standards**— The valve meets API, ASME, and EN standards, making it suitable for use in all world areas. An optional mounting bracket provides ISO 5211 actuator mounting capability.
- **PEEK/PTFE bearing as standard**— The PTFE-lined PEEK bearing is a low friction, low wear bearing. It allows the valve to operate under high pressure drops for a high cycle life while maintaining low torque. The drop-in bearing design enables fast, easy maintenance.
- **Improved shaft-disk pinning**— The improved expansion pin system ensures there is a positive, durable connection between disk and shaft. This reduces backlash and wear in the drive system, optimizing long-term performance. It also makes disassembly for maintenance quick and simple with no need for special tools.
- **New Spring-Loaded Shaft**— The spring in the outboard shaft provides support to the drive train and disk, enabling the shaft to be installed in both horizontal and vertical orientations with no detriment to performance or cycle life. This complements the ability to mount the actuator on the left- or right-hand side, enabling access for any installation.
- **Excellent Emissions Capabilities**— The optional ENVIRO-SEAL™ packing systems, are designed with very smooth shaft surfaces and live-loading to



provide improved sealing, guiding, and loading force transmission. The seal of the ENVIRO-SEAL system can control emissions to below 100 ppm (parts per million).

- **Sour Service Capability**— Depending on material selection, some trim and bolting materials are available for applications involving sour liquids and gases. These constructions comply with NACE MR0175-2002, MR0103, and MR0175 / ISO 15156. Contact your Emerson Process Management sales office for more information.
- **Easy Installation**— Line-centering clips engage the line flange bolts to simplify installation and provide for centering of wafer-style valves in the pipeline. End connections are compatible with EN and ASME standards.
- **Excellent Shutoff Regardless of Pressure Drop**— Both the S31600 (316 stainless steel) seal ring and the bidirectional PTFE seal ring with pressure-assisting sealing action ensure shutoff regardless of flow direction.
- **Long Seal Life**— The opening and closing path of the eccentric disk minimizes disk contact with the seal ring, thereby reducing seal wear, undue friction, and seating torque requirements. See figure 2.

- **Reliable Flange Gasketing Surface**— The seal retainer screws and retention clips are outside the gasket surface of the seal retainer. Spiral-wound or flat-sheet gaskets can be installed between the uninterrupted seal retainer face and the pipeline flange.
- **Integral Shaft-to-Valve Body Bonding**— Standard valve construction includes conductive packing to provide electrical bonding for hazardous area applications.
- **Powder paint as standard**— The Emerson Process Management™ powder paint finish offers an excellent corrosion-resistant finish to all steel parts.
- **High Temperature Capability**— The valve will operate at elevated temperatures, with the appropriate trim components.
- **Shaft Retention**— Redundant shaft retention provides added protection. The packing follower, anti-blowout ring, and shaft groove interact to hold the shaft securely in the valve body (see figure 1).
- **Travel Indication**— Additional travel indication can be achieved by using the indication line on the shaft, along with the disk position markings on the packing follower (see figure 4).

Table of Contents

A81 Features	1	Coefficients	15
A81 Valve Specifications and Materials of Construction	3	FieldQ Actuator Features	17

A81 Valve Specifications and Materials of Construction

Table 1. Fisher A81 Valve Specifications

Specifications		EN	ASME
Valve Body Size		DN 50, 80, 100, 150, 200, 250, and 300	NPS 2, 3, 4, 6, 8, 10, and 12
Pressure Rating		PN 10 to 40 per EN 12516-1	CL150 / 300 per ASME B16.34
Valve Body Materials		EN 1.0619 steel	WCC steel
		EN 1.4409 stainless steel	CF3M (316L) stainless steel
		LCC	LCC
		CW2M ⁽¹⁾	CW2M ⁽¹⁾
		M35-2 ⁽²⁾	M35-2
Disk Materials	PTFE or RPTFE ⁽⁴⁾ Seal	EN 1.4409 stainless steel	CF3M stainless steel
		CW2M	CW2M
	Metal or UHMWPE ⁽³⁾ Seal	Chrome-plated EN 1.4409 Stainless Steel	Chrome-plated CF3M Stainless Steel
End Connections		Mates with raised-face flanges per EN 1092-1	Mates with raised-face flanges per ASME B16.5
Valve Body Style		Wafer (flangeless) and single flange with tapped or through holes ⁽⁵⁾	
Face-to-Face Dimensions		Meets MSS SP68, API 609, and EN 558 standards	
Shutoff		PTFE, RPTFE, or UHMWPE seal ring - No visible leakage per MSS SP-61	
		S31600 (316 SST) seal ring - 0.1 scfh per unit of NPS (NPS 6 valve = 0.6 scfh) per MSS SP-61	
Flow Direction		Standard (forward flow) is with the seal retainer facing upstream; reverse flow is permissible within specified pressure drop limitations	
Flow Characteristic		Approximately linear	
Disk Rotation		Counterclockwise to open (when viewed from actuator side of valve body) through 90 degrees of disk rotation	
Shaft Diameters and Approximate Weights		See table 8	
<p>1. This material is not listed in EN 12516-1 or ASME B16.34. See figure 6 for pressure/temperature ratings. 2. This material is not listed in EN 12516-1. See figure 6 for pressure/temperature ratings. 3. UHMWPE stands for ultra high molecular weight polyethylene. 4. RPTFE is a reinforced PTFE seal. 5. LCC construction is standard in wafer style only. Consult your Emerson Process Management sales office for single flange valve body style information.</p>			

Table 2. Materials (Other Valve Components)

Component	Material
Shafts and Pins	S17400 (17-4PH) stainless steel, S20910 (XM-19) stainless steel, N10276, N05500
Anti-blowout Ring	N07718
Seal	PTFE, RPTFE, or UHMWPE with S31600 (316 stainless steel) or R30003 spring. Metal seal is 316 stainless steel with graphite gaskets
Bearings	PEEK/PTFE, R30006 (Alloy 6), S31600 Nitride
Packing	PTFE/carbon-filled PTFE (standard), graphite die-molded ribbon, ENVIRO-SEAL PTFE packing, ENVIRO-SEAL graphite packing
Follower Spring	N07718 with carbon-filled PEEK or S31600 spring seats
Bolting	B8M Class 2, B7M, N05500, N07718
Nuts	8M, 2HM, N04400, N10276

Table 3. Trim Combinations with Standard Construction Materials

Valve Body Material	Shaft Material	Disk Material	Bearings	Seal Material
1.0619 & WCC	S17400 H1075	1.4409 & CF3M	PEEK/PTFE	PTFE or RPTFE
		1.4409 & CF3M Chrome-Plated	PEEK/PTFE Alloy 6 or S31600 Nitride	UHMWPE or Metal Metal
LCC	S17400 H1075	1.4409 & CF3M	PEEK/PTFE	PTFE
1.4409 & CF3M	S20910	1.4409 & CF3M	PEEK/PTFE	PTFE or RPTFE
		1.4409 & CF3M Chrome-Plated	PEEK/PTFE Alloy 6 or S31600 Nitride	UHMWPE or Metal Metal
CW2M	N10276	CW2M	PEEK/PTFE	PTFE or RPTFE
M35-2	N05500	M35-2	PEEK/PTFE	PTFE or RPTFE

Figure 1. Typical Fisher A81 Valve Construction Detail

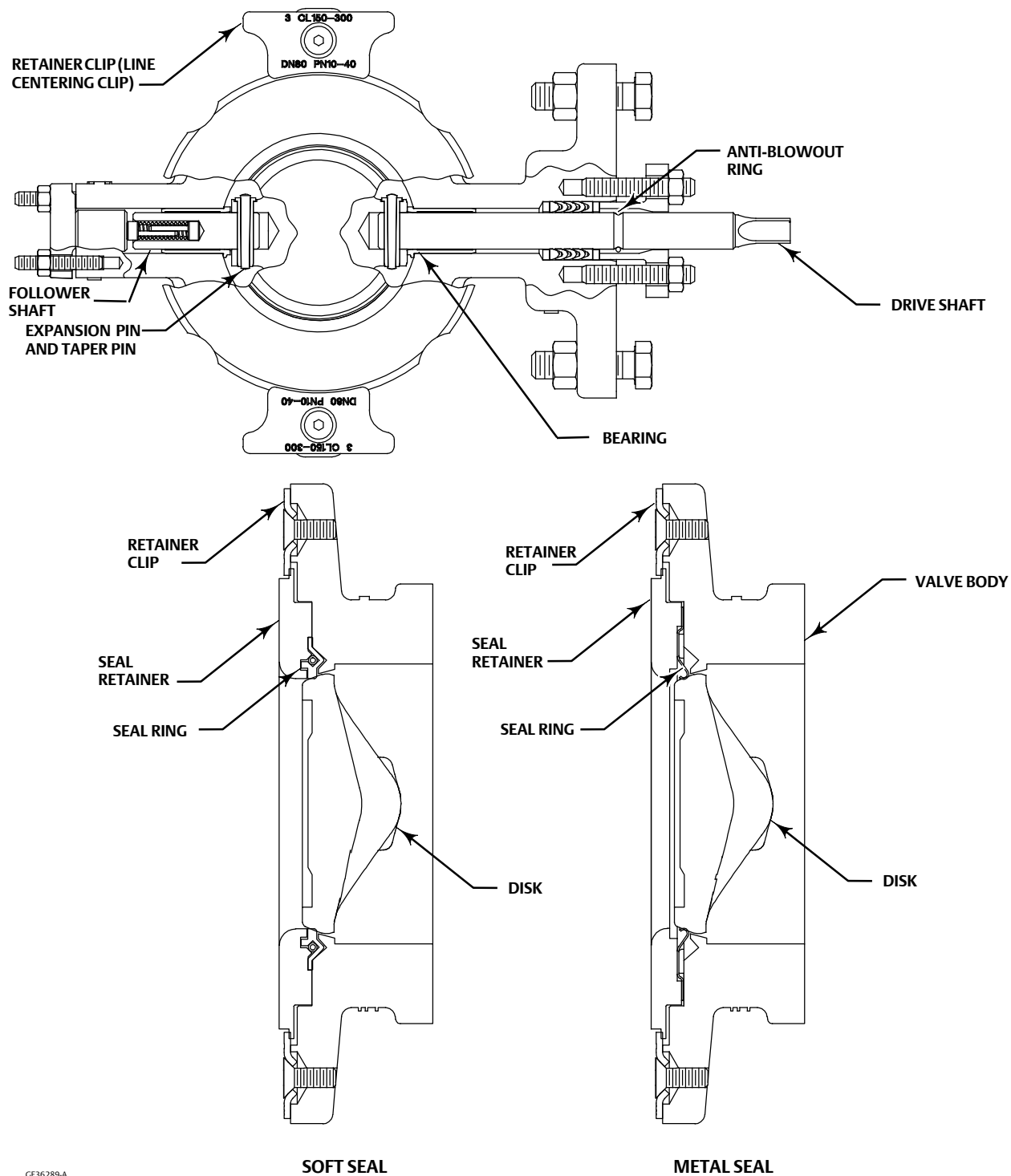

GE36289-A

Figure 2. Comparison of Disk Action

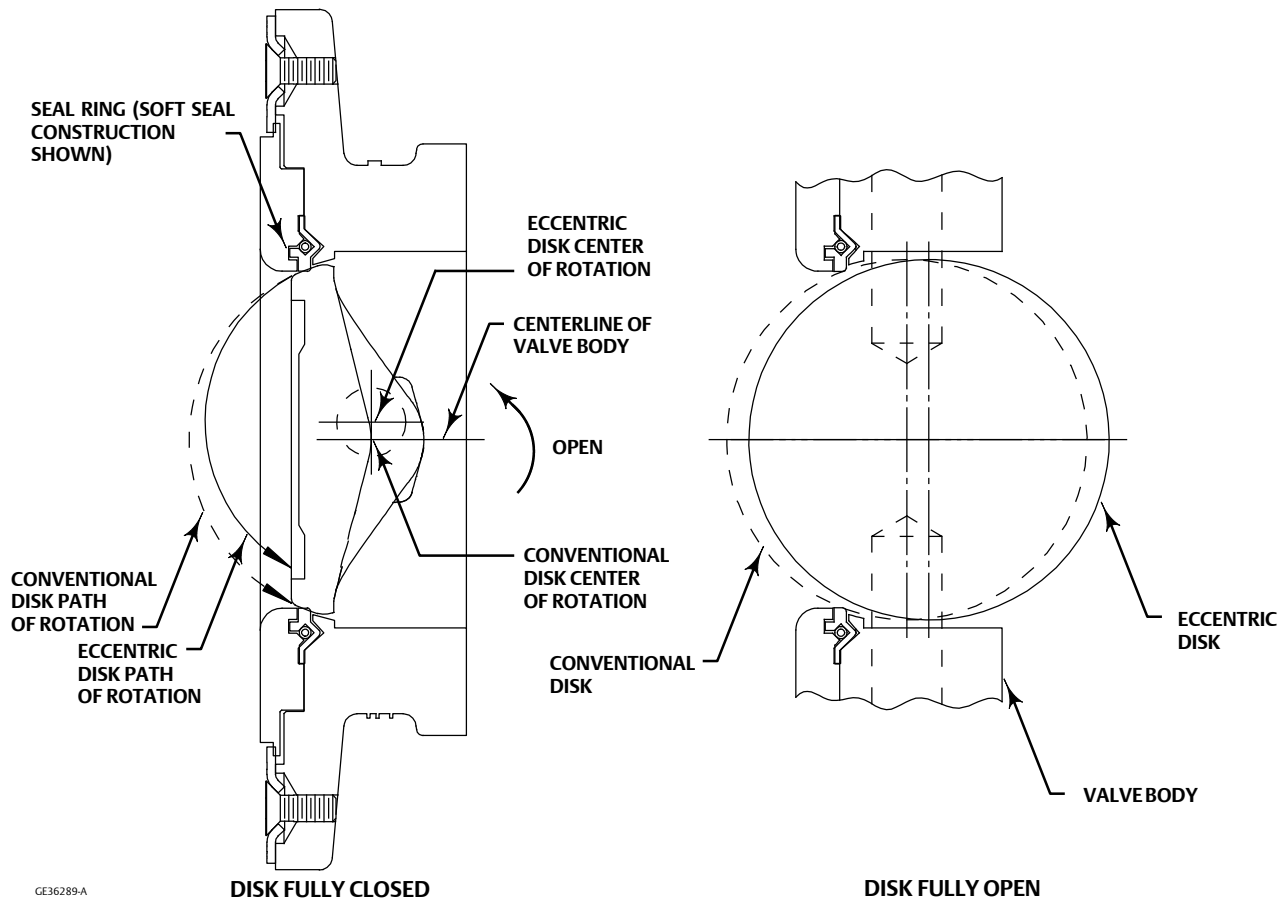

Figure 3. Available Seal Configuration

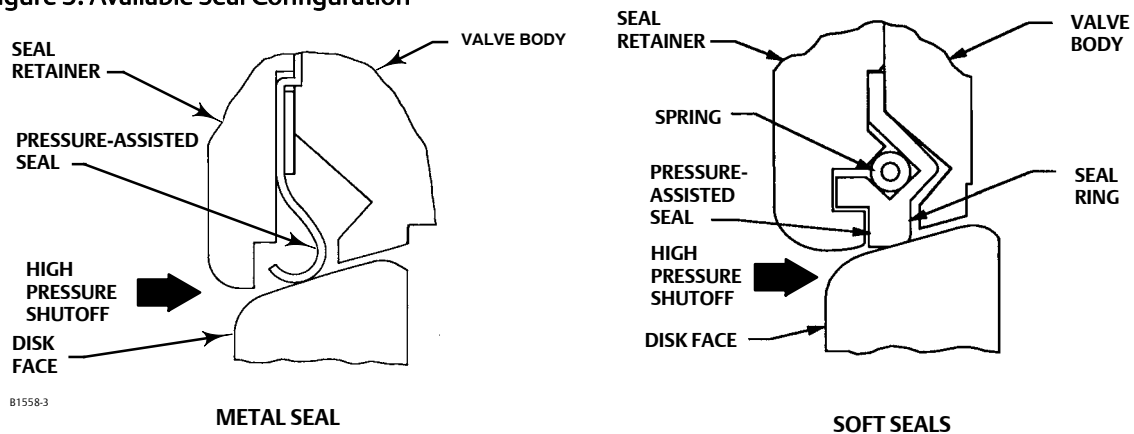
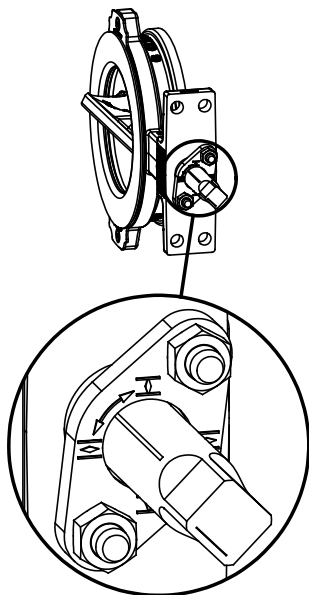

Figure 4. Travel Indication



GE36289

Table 4. Material Temperature Capabilities

MATERIAL					TEMPERATURE LIMITS	
PN FLANGES					°C	°F
Valve Body	Shaft	Bearing Lining and Jacket	Seal	Packing		
1.0619 Steel	S17400 or S20910	PEEK / PTFE	PTFE or RPTFE	PTFE or Graphite	-10 to 232	14 to 450
			UHMWPE	PTFE or Graphite	-10 to 93	14 to 200
			Metal	PTFE	-10 to 232	14 to 450
				Graphite	-10 to 260	14 to 500
		R30006 (Alloy 6) or S31600 Nitride	Metal	Graphite	-10 to 400 ⁽¹⁾	14 to 752 ⁽¹⁾
LCC	S17400 or S20910	PEEK / PTFE	PTFE	PTFE	-46 to 232	-50 to 450
1.4409 Stainless Steel	S20910	PEEK / PTFE	PTFE or RPTFE	PTFE or Graphite	-46 to 232	-50 to 450
			UHMWPE	PTFE or Graphite	-18 to 93	0 to 200
			Metal	PTFE	-46 to 232	-50 to 450
				Graphite	-46 to 260	-50 to 500
		R30006 (Alloy 6) or S31600 Nitride	Metal	Graphite	-46 to 500 ⁽¹⁾	-50 to 932 ⁽¹⁾
CW2M	N10276	PEEK / PTFE	PTFE or RPTFE	PTFE	-10 to 232	14 to 450
M35-2	N05500	PEEK / PTFE	PTFE or RPTFE	PTFE	-10 to 232	14 to 450
ASME FLANGES						
Valve Body	Shaft	Bearing Lining and Jacket	Seal	Packing	°C	°F
WCC steel	S17400 or S20910	PEEK / PTFE	PTFE or RPTFE	PTFE or Graphite	-29 to 232	-20 to 450
			UHMWPE	PTFE or Graphite	-18 to 93	0 to 200
			Metal	PTFE	-29 to 232	-20 to 450
				Graphite	-29 to 260	-20 to 500
		R30006 (Alloy 6) or S31600 Nitride	Metal	Graphite	-29 to 427 ⁽¹⁾	-20 to 800 ⁽¹⁾
LCC	S17400 or S20910	PEEK / PTFE	PTFE	PTFE	-46 to 232	-50 to 450
CF3M Stainless Steel	S20910	PEEK / PTFE	PTFE or RPTFE	PTFE or Graphite	-46 to 232	-50 to 450
			UHMWPE	PTFE or Graphite	-18 to 93	0 to 200
			Metal	PTFE	-46 to 232	-50 to 450
				Graphite	-46 to 260	-50 to 500
		R30006 (Alloy 6) or S31600 Nitride	Metal	Graphite	-46 to 454 ⁽¹⁾	-50 to 850 ⁽¹⁾
CW2M	N10276	PEEK / PTFE	PTFE or RPTFE	PTFE	-46 to 232	-50 to 450
M35-2	N05500	PEEK / PTFE	PTFE or RPTFE	PTFE	-46 to 232	-50 to 450

1. For applications exceeding 316°C (600°F), consult your Emerson Process Management sales office for appropriate disk material selection.

Figure 5. Material Pressure/Temperature Curves

Pressure-Temperature Chart for WCC/1.0619

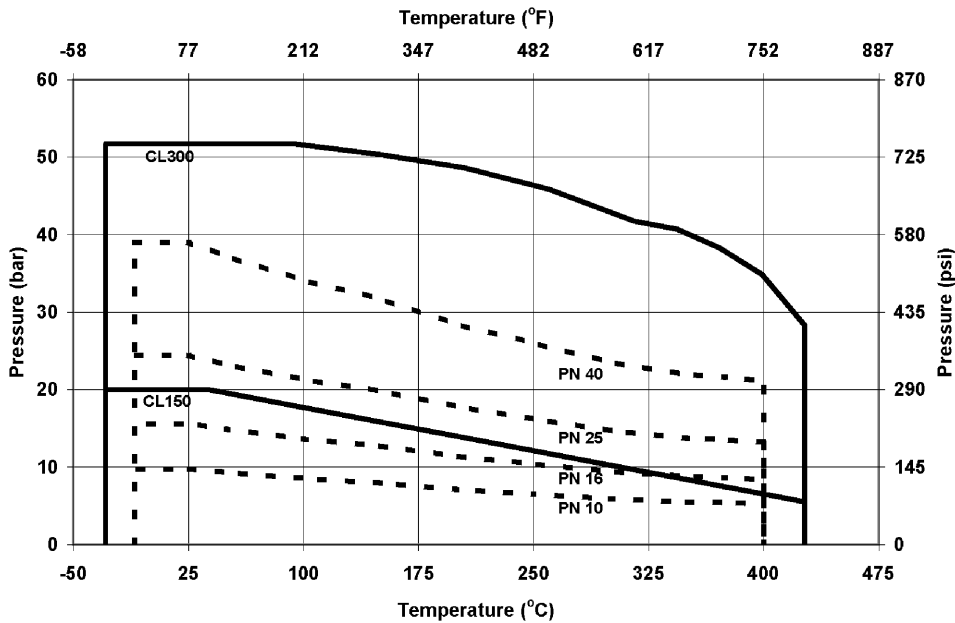

Pressure-Temperature Chart for CF3M/1.4409

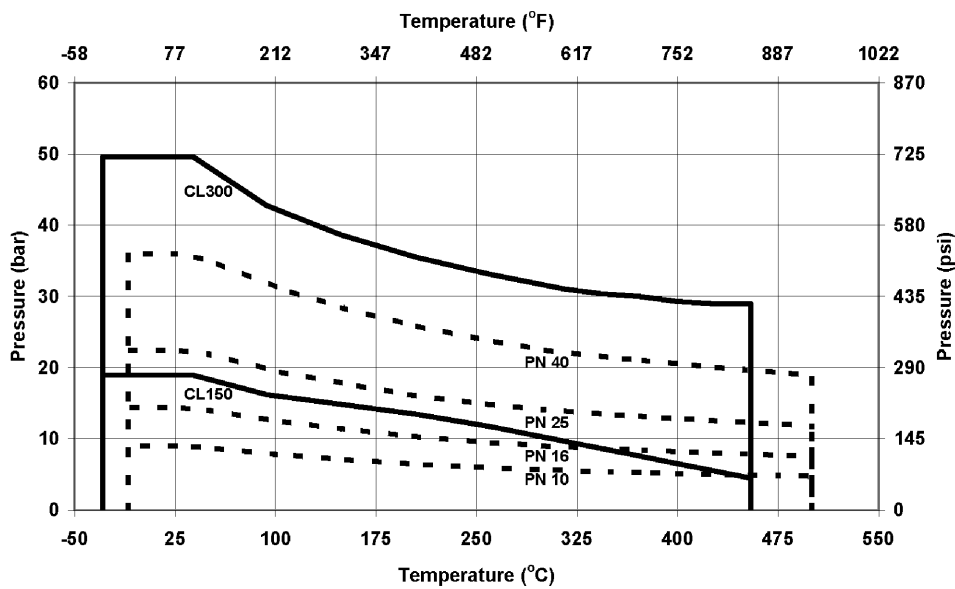
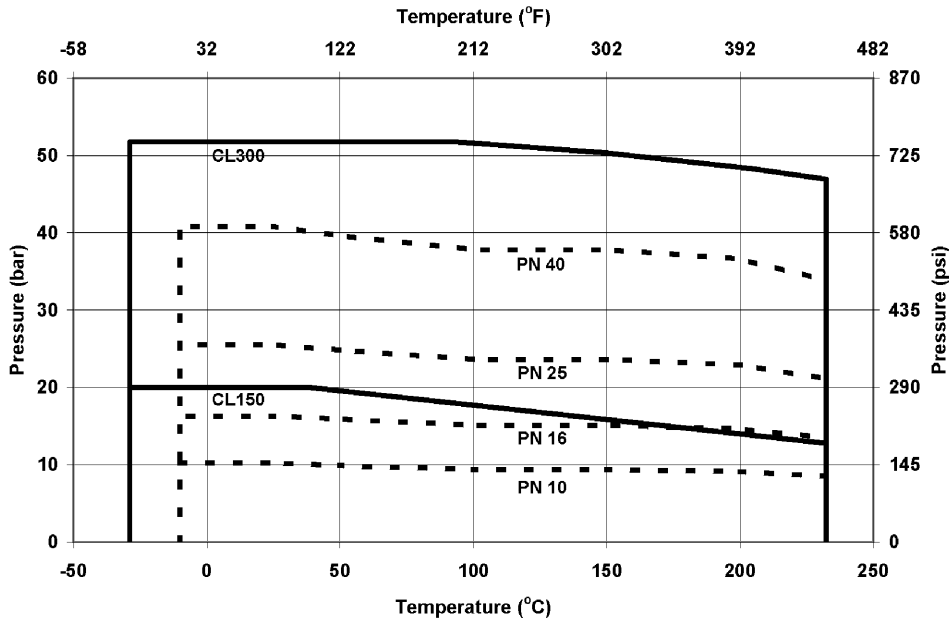
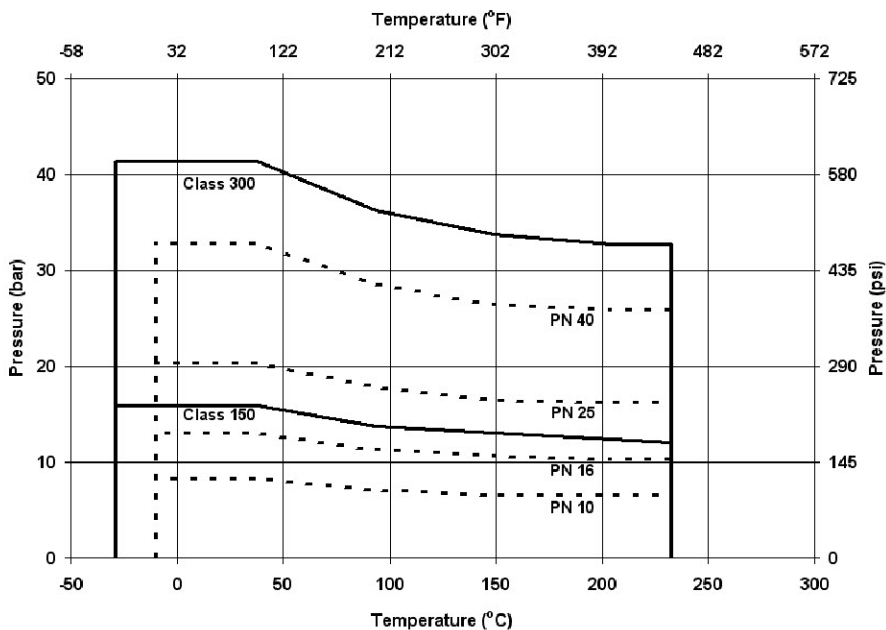

Figure 6. Material Pressure/Temperature Curves

Pressure-Temperature Chart for CW2M ◀ 1



Pressure-Temperature Chart for M35-2 ◀ 2



1. CW2M is not listed in EN 12516-1 or ASME B16.34. The PN and CL designations are used only to indicate relative pressure-retaining capabilities.
2. M35-2 is not listed in EN 12516-1. The PN designations are used only to indicate relative pressure-retaining capabilities.

Figure 7. Material Pressure/Temperature Curves

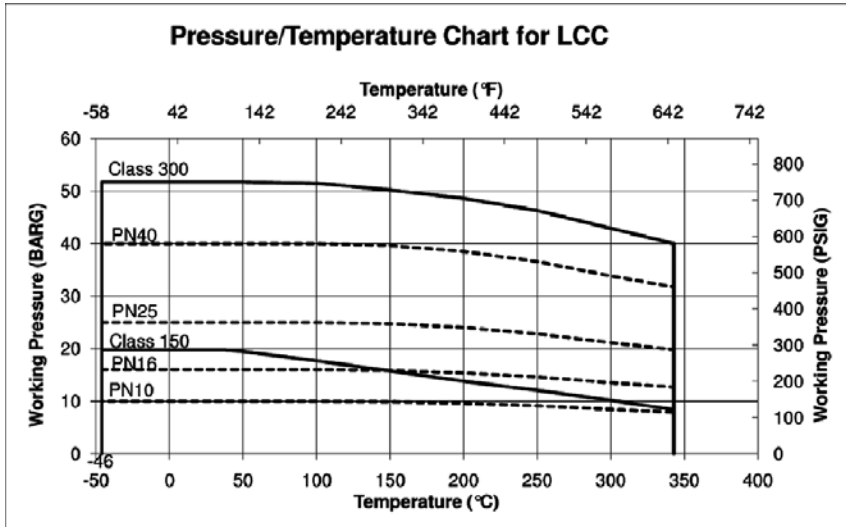

E1140

Table 5. Maximum Allowable Shutoff Pressure Drops based on Trim (Seal, Shaft, and Bearings), Bar

Note: Do not exceed the EN or ASME pressure/temperature rating of the valve or mating flanges.

TRIM	TEMPERATURE, °C	DN						
		50	80	100	150	200	250	300
		Bar						
PTFE or RPTFE Seal PEEK/PTFE Bearings	-45 to 65	51.7	51.7	51.7	51.7	51.7	35.2	41.4
	93	48.5	48.5	48.5	48.5	48.5	35.0	38.8
	121	38.6	38.6	38.6	38.6	38.6	33.8	35.7
	149	28.7	28.7	28.7	28.7	28.7	28.7	28.7
	191	13.8	13.8	13.8	13.8	13.8	13.8	13.8
	204	10.3	10.3	10.3	10.3	10.3	10.3	10.3
	232	3.4	3.4	3.4	3.4	3.4	3.4	3.4
UHMWPE Seal PEEK/PTFE Bearings	-17 to 37	51.7	51.7	51.7	51.7	51.7	35.2	41.4
	66	38.6	38.6	38.6	38.6	38.6	35.1	38.6
	93	25.9	25.9	25.9	25.9	25.9	25.9	25.9
Metal Seal ⁽¹⁾ Alloy 6 Bearings	-45 to 37	18.5	16.5	13.9	12.8	11.0	6.8	7.0
	93	17.0	15.1	12.8	11.7	10.1	6.3	6.5
	149	16.0	14.2	12.0	11.0	9.4	5.9	6.1
	204	15.1	13.4	11.4	10.4	9.0	5.6	5.7
	260	14.3	12.8	10.8	9.9	8.5	5.3	5.4
	316	13.8	12.3	10.3	9.5	8.2	5.1	5.2
	371	13.2	11.9	10.0	9.2	7.9	5.0	5.0
	427	12.5	11.6	9.8	9.0	7.7	4.8	5.0
454	12.1	11.5	9.7	8.9	7.7	4.8	4.9	
Metal Seal ⁽¹⁾ S31600/Nitride Bearings	-45 to 37	19.5	22.4	26.1	20.8	27.6	12.8	8.0
	93	19.3	22.4	26.0	20.6	27.6	12.8	7.9
	149	17.0	22.4	23.7	18.7	27.6	12.8	7.1
	204	15.9	22.4	22.7	17.8	26.3	12.8	6.8
	260	14.5	22.4	21.4	16.8	24.6	12.5	6.3
	316	13.8	22.1	20.8	16.2	23.2	12.1	6.1
	371	13.2	21.5	20.2	15.7	22.4	11.8	5.9
	427	12.5	20.7	19.5	15.2	21.8	11.4	5.6
454	12.1	20.3	19.2	14.9	21.6	11.2	5.4	
Metal Seal ⁽¹⁾ PEEK/PTFE Bearings	-45 to 37	51.7	51.7	51.7	51.7	31.0	17.2	17.2
	93	51.7	51.7	51.7	51.7	31.0	17.2	17.2
	149	50.3	50.3	50.3	50.3	31.0	17.2	17.2
	204	48.6	48.6	48.6	48.2	31.0	17.2	17.2
	232	47.2	47.2	46.3	42.6	31.0	17.2	17.2
	260	24.7	21.9	18.5	17.0	14.6	9.1	9.4

1. Pressure drops shown for metal seals are for forward flow only. For reverse flow with metal seal, limit pressure drop to 7 bar (100 psi).

Table 6. Maximum Allowable Shutoff Pressure Drops based on Trim (Seal, Shaft, and Bearings), Psi

Note: Do not exceed the EN or ASME pressure/temperature rating of the valve or mating flanges.

TRIM	TEMPERATURE, °F	NPS						
		2	3	4	6	8	10	12
		Psi						
PTFE or RPTFE Seal PEEK/PTFE Bearings	-50 to 150	750	750	750	750	750	511	600
	200	704	704	704	704	704	508	563
	250	560	560	560	560	560	490	518
	300	416	416	416	416	416	416	416
	375	200	200	200	200	200	200	200
	400	150	150	150	150	150	150	150
	450	50	50	50	50	50	50	50
UHMWPE Seal PEEK/PTFE Bearings	0 to 100	750	750	750	750	750	511	600
	150	560	560	560	560	560	509	560
	200	375	375	375	375	375	375	375
Metal Seal ⁽¹⁾ Alloy 6 Bearings	-50 to 100	268	239	202	185	159	99	102
	200	246	219	185	170	146	91	94
	300	232	206	174	160	137	86	88
	400	219	195	165	151	130	81	83
	500	208	186	157	144	124	77	79
	600	200	178	150	138	119	74	76
	700	192	172	145	134	115	72	73
	800	181	168	142	130	112	70	72
	850	176	167	141	129	111	69	71
Metal Seal ⁽¹⁾ S31600/Nitride Bearings	-50 to 100	283	325	379	301	400	185	116
	200	280	325	377	299	400	185	115
	300	246	325	344	271	400	185	103
	400	230	325	329	258	382	185	98
	500	211	325	311	243	357	182	91
	600	200	321	301	235	337	176	88
	700	192	312	293	228	325	171	85
	800	181	300	283	220	316	165	81
850	176	295	278	216	313	162	79	
Metal Seal ⁽¹⁾ PEEK/PTFE Bearings	-50 to 100	750	750	750	750	450	250	250
	200	750	750	750	750	450	250	250
	300	730	730	730	730	450	250	250
	400	705	705	705	699	450	250	250
	450	685	685	672	618	450	250	250
	500	358	318	269	247	212	132	136

1. Pressure drops shown for metal seals are for forward flow only. For reverse flow with metal seal, limit pressure drop to 7 bar (100 psi).

Table 7. ISO 5211 F Sizes Available with Optional Mounting Bracket

VALVE SIZE		ISO 5211 F SIZES
DN	NPS	
50	2	F07, F10
80	3	F07, F10
100	4	F07, F10, F12, F14, F16
150	6	F07, F10, F12, F14, F16
200	8	F10, F12, F14, F16
250	10	F10, F12, F14, F16
300	12	F10, F12, F14, F16

Table 8. Dimensions and Weights

VALVE SIZE / PRESSURE RATING		A	C	D	E	F		G		K	R	S ⁽¹⁾	T	U	W	APPROXIMATE WEIGHT ⁽²⁾	
						(4)	(5)	(4)	(5)							(4)	(5)
						mm											
DN50/ NPS 2	PN10-40/ CL150- 300	43	9	15	74	150	---	109	---	125	102	12.7	117	---	14	4.7	6.7
DN80/ NPS 3	PN10-40/ CL150- 300	47/ 48 (3)	11	15	76	196	196	133	133	130	134	15.9	117	---	14	7.5	11.2
DN100/ NPS 4	PN10-40/ CL150- 300	53	14	19	103	222	226	122	147	172	162	19.1	152	32	14	12.5	17.6
DN150/ NPS 6	PN10-40/ CL150- 300	57	19	25	108	270	300	147	182	205	218	25.4	152	32	14	15.7	26.5
DN200/ NPS 8	PN10-16/ CL150	61	22	30	107	327	342	225	225	258	271	31.8	235	46	18	30.2	40.2
	PN25-40/ CL300	73	22	30	107	358	364	225	225	258	285	31.8	235	46	18	33.9	46.0
DN250/ NPS 10	PN10-16/ CL150	69	22	30	109	390	395	218	250	270	324	31.8	235	46	18	38.9	50.5
	PN25-40/ CL300	83	22	30	109	400	450	265	265	270	345	31.8	235	46	18	51.8	79.2
DN300/ NPS 12	PN10-16/ CL150	78	27	35	114	381	467	309	309	304	381	38.1	235	46	18	68.7	98.3
	PN25-40/ CL300	92	27	35	114	410	512	309	309	304	410	38.1	235	46	18	76.6	105
		Inches														lbs	
DN50/ NPS 2	PN10-40/ CL150- 300	1.69	0.35	0.59	2.91	5.91	---	4.29	---	4.92	4.02	0.50	4.62	---	0.55	10	15
DN80/ NPS 3	PN10-40/ CL150- 300	1.85/ 1.89 (3)	0.43	0.59	2.99	7.72	7.72	5.24	5.24	5.12	5.28	0.63	4.62	---	0.55	17	25
DN100/ NPS 4	PN10-40/ CL150- 300	2.09	0.55	0.75	4.06	8.74	8.90	4.80	5.79	6.77	6.38	0.75	6.00	1.25	0.55	28	39
DN150/ NPS 6	PN10-40/ CL150- 300	2.24	0.75	0.94	4.25	10.63	11.81	5.79	7.17	8.07	8.58	1.00	6.00	1.25	0.55	35	58
DN200/ NPS 8	PN10-16/ CL150	2.40	0.87	1.18	4.21	12.87	13.46	8.86	8.86	10.16	10.67	1.25	9.25	1.81	0.71	67	89
	PN25-40/ CL300	2.87	0.87	1.18	4.21	14.09	14.33	8.86	8.86	10.16	11.22	1.25	9.25	1.81	0.71	75	102
DN250/ NPS 10	PN10-16/ CL150	2.72	0.87	1.18	4.29	15.35	15.55	8.58	9.84	10.63	12.76	1.25	9.25	1.81	0.71	86	111
	PN25-40/ CL300	3.27	0.87	1.18	4.29	15.75	17.72	10.43	10.43	10.63	13.58	1.25	9.25	1.81	0.71	114	175
DN300/ NPS 12	PN10-16/ CL150	3.07	1.06	1.38	4.49	15.00	18.39	12.17	12.17	11.97	15.00	1.50	9.25	1.81	0.71	151	217
	PN25-40/ CL300	3.62	1.06	1.38	4.49	16.14	20.16	12.17	12.17	11.97	16.14	1.50	9.25	1.81	0.71	169	231

1. This nominal valve shaft diameter is the shaft diameter through the packing box. Use this diameter when selecting Fisher actuators.
2. Valve assembly only.
3. 48 mm for CL150 and CL300 single flange only.
4. Wafer
5. Single Flange

Table 9. Line Bolting Dimensions

VALVE SIZE	Y					
	Pressure Rating					
	CL150	CL300	PN10	PN16	PN25	PN40
DN80 / NPS 3	4X 5/8-11	8X 3/4-10	8X M20X2.5			
DN100 / NPS 4	8X 5/8-11	8X 3/4-10	8X M16X2		8X M20X2.5	
DN150 / NPS 6	8X 3/4-10	12X 3/4-10	8X M20X2.5		8X M24X3 ⁽¹⁾	
DN200 / NPS 8	8X 3/4-10	12X 7/8-9	8X M20X2.5	12X M20X2.5	12X M24X3	12X M27X3 ⁽¹⁾
DN250 / NPS 10	12X 7/8-9	16X 1-8	12X M20X2.5	12X M24X3	12X M27X3	12X M30X3.5 ⁽¹⁾
DN300 / NPS 12	12X 7/8-9	16X 1-1/8-8	12X M20X2.5	12X M24X3	16X M27X3	16X M30X3.5

1. Not available in single flange with threaded holes.

Figure 8. Dimensions for Fisher A81, Single Flange Valve

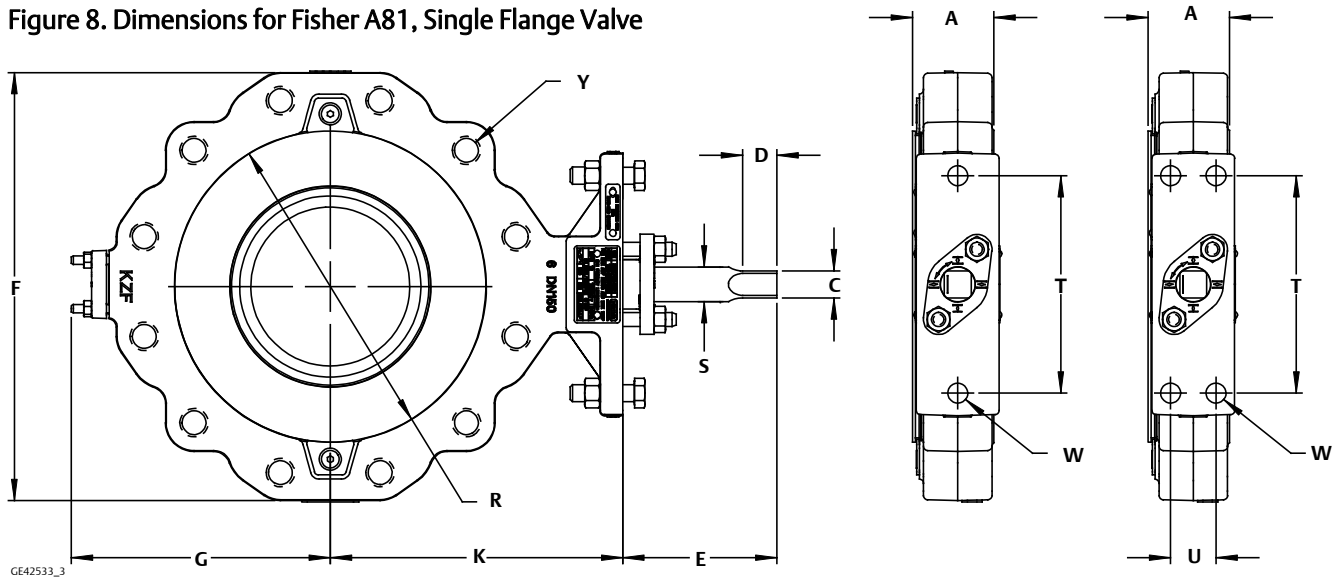

Figure 9. Dimensions for Fisher A81, Wafer Style Valve

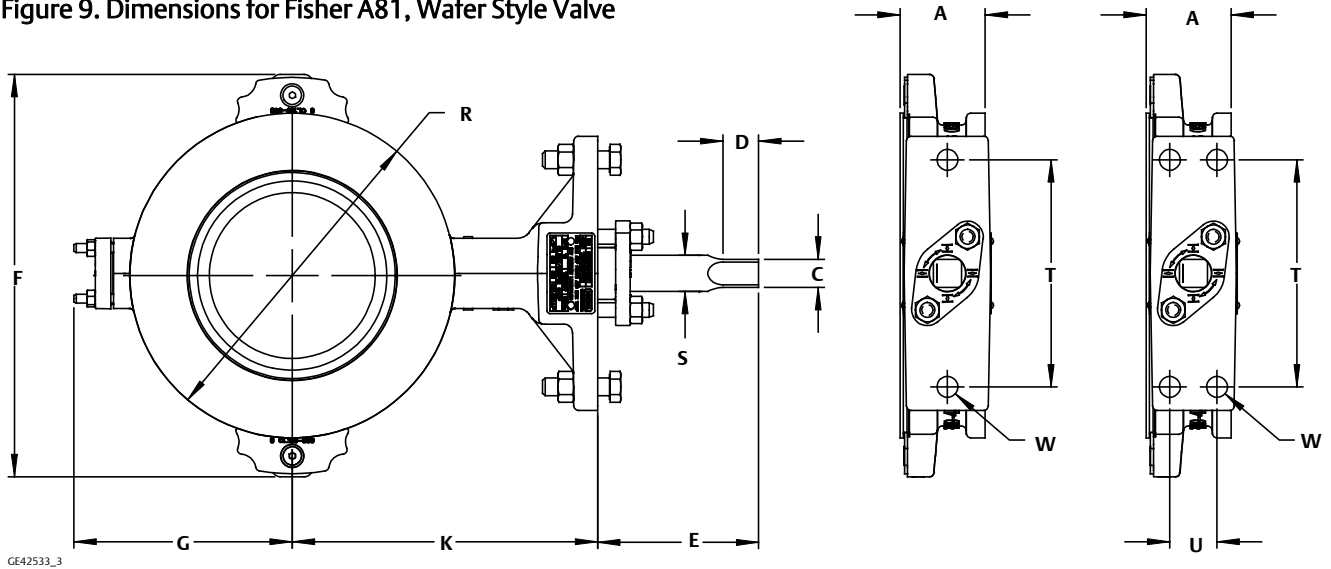
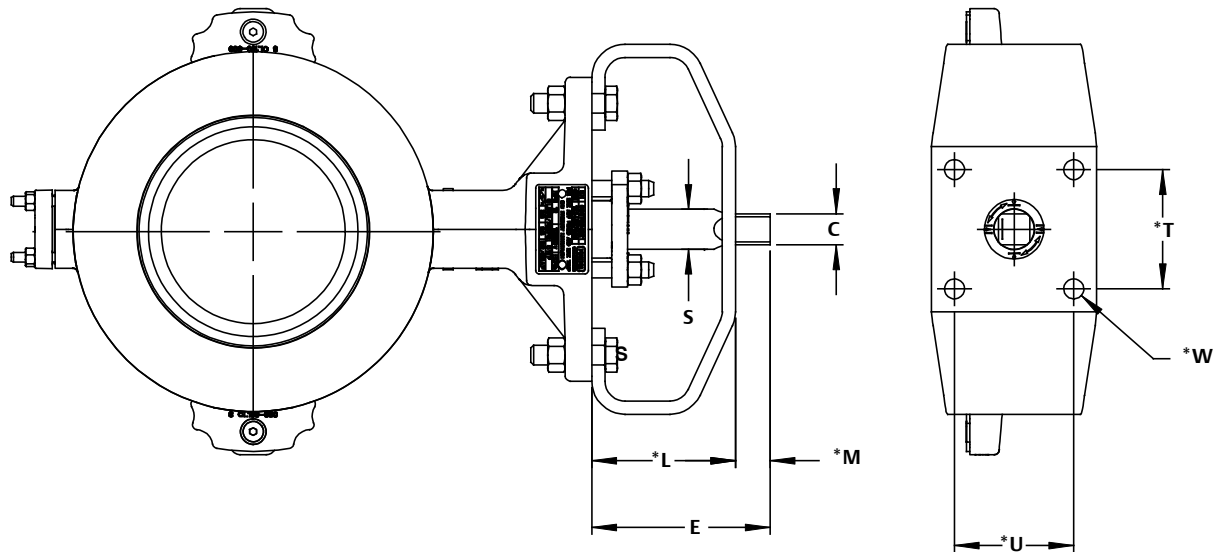

Table 10. Dimensions and Weights, Optional Mounting Bracket

VALVE SIZE / PRESSURE RATING		S ⁽¹⁾		C		E		L		M		T		U		W		ISO 5211
		mm	inch	mm	inch	mm	inch	mm	inch	mm	inch	mm	inch	mm	inch	mm	inch	
DN50/ NPS 2	PN10-40/ CL150-300	12.7	0.50	9	0.35	74	2.91	64	2.52	10	0.39	49.50	1.95	49.50	1.95	10	0.39	F07
		72.12	2.84	72.12	2.84	12	0.47	49.50	1.95	49.50	1.95	10	0.39	F10				
DN80/ NPS 3	PN10-40/ CL150-300	15.9	0.63	11	0.43	76	2.99	64	2.52	12	0.47	49.50	1.95	49.50	1.95	10	0.39	F07
		72.12	2.84	72.12	2.84	12	0.47	49.50	1.95	49.50	1.95	10	0.39	F10				
DN100/ NPS 4	PN10-40/ CL150-300	19.1	0.75	14	0.55	103	4.06	87	3.43	16	0.63	49.50	1.95	49.50	1.95	10	0.39	F07
		72.12	2.84	72.12	2.84	12	0.47	49.50	1.95	49.50	1.95	10	0.39	F10				
		88.39	3.48	88.39	3.48	14	0.55	88.39	3.48	14	0.55	F12						
DN150/ NPS 6	PN10-40/ CL150-300	25.4	1.00	19	0.75	108	4.25	87	3.43	21	0.82	49.50	1.95	49.50	1.95	10	0.39	F07
		72.12	2.84	72.12	2.84	12	0.47	49.50	1.95	49.50	1.95	10	0.39	F10				
		88.39	3.48	88.39	3.48	14	0.55	88.39	3.48	14	0.55	F12						
		99.00	3.90	99.00	3.90	18	0.71	99.00	3.90	18	0.71	F14						
DN200/ NPS 8	PN10-16/ CL150	31.8	1.25	22	0.87	107	4.21	85	3.35	22	0.87	72.12	2.84	72.12	2.84	12	0.47	F10
		88.39	3.48	88.39	3.48	14	0.55	88.39	3.48	14	0.55	F12						
	PN25-40/ CL300	31.8	1.25	22	0.87	107	4.21	85	3.35	22	0.87	99.00	3.90	99.00	3.90	18	0.71	F14
DN250/ NPS 10	PN10-16/ CL150	31.8	1.25	22	0.87	109	4.29	85	3.35	24	0.94	72.12	2.84	72.12	2.84	12	0.47	F10
		88.39	3.48	88.39	3.48	14	0.55	88.39	3.48	14	0.55	F12						
	PN25-40/ CL300	31.8	1.25	22	0.87	109	4.29	85	3.35	24	0.94	99.00	3.90	99.00	3.90	18	0.71	F14
DN300/ NPS 12	PN10-16/ CL150	38.1	1.50	27	1.06	114	4.49	85	3.35	29	1.14	72.12	2.84	72.12	2.84	12	0.47	F10
		88.39	3.48	88.39	3.48	14	0.55	88.39	3.48	14	0.55	F12						
	PN25-40/ CL300	38.1	1.50	27	1.06	114	4.49	85	3.35	29	1.14	99.00	3.90	99.00	3.90	18	0.71	F14
		116.67	4.59	116.67	4.59	22	0.87	116.67	4.59	22	0.87	F16						

1. This nominal valve shaft diameter is the shaft diameter through the packing box. Use this diameter when selecting Fisher actuators.

Figure 10. Dimensions for Fisher A81, Wafer Style Valve with Optional Mounting Bracket



GE42533_3

Coefficients

Table 11. Fisher A81 Valve

Valve Size		Coefficients	Valve Rotation, Degrees								
DN	NPS		10	20	30	40	50	60	70	80	90
50	2	C _v	2.28	7.7	21.5	35.5	51	58.9	62.4	78.3	83.7
		K _v	1.97	6.7	18.6	30.7	44.1	50.9	53.9	67.7	72.3
		F _d	0.16	0.21	0.21	0.25	0.29	0.32	0.36	0.37	0.39
		F _L	---	0.91	0.84	0.76	0.73	0.78	0.80	0.68	0.66
		X _T	---	0.76	0.53	0.39	0.39	0.52	0.54	0.39	0.35
80	3	C _v	3.50	22.1	46.3	73.1	120	147	181	239	275
		K _v	3.02	19.1	40.0	63.2	103.7	127	156	206	238
		F _d	0.10	0.17	0.23	0.27	0.32	0.33	0.41	0.47	0.51
		F _L	0.77	0.81	0.79	0.79	0.69	0.70	0.67	0.62	0.58
		X _T	0.46	0.60	0.54	0.55	0.40	0.37	0.35	0.29	0.23
100	4	C _v	9.40	48.8	90.6	137	171	224	297	397	484
		K _v	8.12	42.2	78.3	118	148	194	257	343	418
		F _d	0.10	0.18	0.23	0.28	0.33	0.38	0.43	0.50	0.53
		F _L	0.9	0.83	0.80	0.77	0.77	0.74	0.68	0.62	0.58
		X _T	0.48	0.47	0.48	0.48	0.46	0.39	0.32	0.26	0.22
150	6	C _v	26.2	99.1	181	283	401	543	717	951	1000
		K _v	22.6	85.6	156	245	346	469	619	822	864
		F _d	0.10	0.18	0.26	0.31	0.36	0.40	0.43	0.47	0.49
		F _L	0.82	0.79	0.77	0.74	0.72	0.68	0.66	0.61	0.58
		X _T	0.44	0.48	0.52	0.48	0.42	0.36	0.32	0.26	0.22
200	8	C _v	44.6	138	285	457	698	994	1390	2190	2550
		K _v	38.5	119	246	395	603	859	1201	1892	2203
		F _d	0.13	0.20	0.25	0.31	0.37	0.43	0.47	0.51	0.55
		F _L	0.86	0.94	0.82	0.71	0.68	0.67	0.61	0.54	0.47
		X _T	0.49	0.43	0.54	0.52	0.45	0.36	0.31	0.18	0.14
250	10	C _v	72.0	225	423	729	1150	1720	2440	3370	3720
		K _v	62.2	194	365	630	994	1486	2108	2912	3214
		F _d	0.12	0.18	0.23	0.26	0.36	0.41	0.45	0.57	0.54
		F _L	0.89	0.78	0.82	0.75	0.70	0.66	0.60	0.55	0.50
		X _T	0.53	0.42	0.57	0.49	0.41	0.32	0.23	0.18	0.16
300	12	C _v	128	401	733	1220	1800	2490	3380	4470	5080
		K _v	111	346	633	1054	1555	2151	2920	3862	4389
		F _d	0.13	0.19	0.25	0.31	0.38	0.44	0.47	0.50	0.53
		F _L	0.83	0.73	0.74	0.70	0.69	0.66	0.61	0.51	0.50
		X _T	0.41	0.34	0.46	0.42	0.36	0.30	0.24	0.18	0.16

Table 12. Fisher A81 Valve Breakout Torque Requirements

TRIM CONFIGURATION: SOFT SEAL WITH PEEK/PTEF BEARINGS										
VALVE SIZE	SHAFT DIA	TORQUE, N•m								
		Shutoff ΔP_{max}								
DN	mm	3 bar	7 bar	10 bar	15 bar	20 bar	25 bar	35 bar	45 bar	50 bar
50	12.7	12.8	14.7	16.2	18.7	21.1	23.6	28.5	33.4	35.9
80	15.9	19.7	23.4	26.1	30.7	35.3	39.9	49.1	58.2	62.8
100	19.1	31.1	37.6	42.4	50.5	58.7	66.8	83.0	99.2	107
150	25.4	60.8	75.9	87.2	106	125	144	181	219	238
200	31.8	103	135	158	198	237	276	355	434	473
250	31.8	159	212	252	318	385	451	584	---	---
300	38.1	228	310	371	473	576	678	883	---	---
VALVE SIZE	SHAFT DIA	TORQUE, Lbf•in								
		Shutoff ΔP_{max}								
NPS	Inch	50 psid	100 psid	150 psid	200 psid	300 psid	400 psid	500 psid	600 psid	750 psid
2	1/2	115	130	145	160	190	220	250	280	325
3	5/8	178	206	234	262	318	374	430	486	570
4	3/4	282	331	381	430	529	628	727	826	975
6	1	553	668	783	898	1130	1360	1590	1820	2160
8	1-1/4	945	1190	1430	1670	2150	2630	3110	3590	4310
10	1-1/4	1460	1870	2270	2680	3490	4300	5110	---	---
12	1-1/2	2100	2720	3350	3970	5220	6470	7720	8970	---
TRIM CONFIGURATION: METAL SEAL WITH METAL BEARINGS										
VALVE SIZE	SHAFT DIA	TORQUE, N•m								
		Shutoff ΔP_{max}								
DN	mm	3 bar	7 bar	10 bar	15 bar	20 bar	25 bar	35 bar	45 bar	50 bar
50	12.7	37.3	42.4	46.2	52.5	---	---	---	---	---
80	15.9	67.7	78.9	87.3	101	115	---	---	---	---
100	19.1	112	134	151	178	208	233	---	---	---
150	25.4	241	292	331	395	458	---	---	---	---
200	31.8	310	422	506	646	786	927	---	---	---
250	31.8	598	761	884	---	---	---	---	---	---
300	38.1	926	1270	---	---	---	---	---	---	---
VALVE SIZE	SHAFT DIA	TORQUE, Lbf•in								
		Shutoff ΔP_{max}								
NPS	Inch	50 psid	100 psid	150 psid	200 psid	300 psid	400 psid	500 psid	600 psid	750 psid
2	1/2	336	374	413	451	---	---	---	---	---
3	5/8	611	696	782	867	1040	---	---	---	---
4	3/4	1020	1180	1350	1520	1850	---	---	---	---
6	1	2190	2580	2970	3360	4140	---	---	---	---
8	1-1/4	2860	3710	4570	5420	7130	---	---	---	---
10	1-1/4	5450	6700	7950	---	---	---	---	---	---
12	1-1/2	8540	11200	---	---	---	---	---	---	---

FieldQ Actuator Features

- **Simple, modular construction**—Makes operation and maintenance easier. The basic actuator module includes the pistons, rack and pinion gear, springs (for spring-return actuators), housing, and position indicator. Pneumatic operation is accomplished with an ASCO 8551 solenoid valve. The solenoid is activated by a 120 VAC 60 Hz or 110 VAC 50 Hz signal. It is pad mounted and does not require a bracket. The basic actuator features built-in visual position indication, travel stops for both directions, and a balanced pinion design.
- **Three Point Suspension System**—Three carbon-filled PTFE guide bands provide a low friction bearing surface for piston alignment and rack support. Elimination of metal-to-metal contact between pistons and cylinder wall reduces friction for outstanding cycle life, smooth piston travel, and maximum power.
- **Balanced Piston Design**—As part of the design, three equally spaced bearing surfaces are cast into each

piston. The rack and pinion construction results in even distribution of bearing loads, optimum gear engagement, and reduced piston tilt. Equal spring force applied to each piston enhances actuator life.

- **Multiple Constructions**—Conversion from double acting to spring return, or vice versa, is simple and safe, thus reducing spare part requirements. Valve/actuator action is also field reversible.
- **Dual Stop Adjustment**— This adjustment is standard on all E Series actuators. The P Series actuators are supplied with a limit plate adjustment feature.
- **Dual Piston Design**—Air pressure applies a balanced force across the common pinion gear. Symmetrically balanced center mount construction eliminates undue stress on the valve stem, bearings, and disk.

For further information, refer to:
<http://www.emersonprocess.com/valveautomation/fieldq/index.html>

Neither Emerson, Emerson Process Management, nor any of their affiliated entities assumes responsibility for the selection, use or maintenance of any product. Responsibility for proper selection, use, and maintenance of any product remains solely with the purchaser and end user.

Fisher, POSI-SEAL, FieldQ, and ENVIRO-SEAL are marks owned by one of the companies in the Emerson Process Management business division of Emerson Electric Co. Emerson Process Management, Emerson, and the Emerson logo are trademarks and service marks of Emerson Electric Co. All other marks are the property of their respective owners.

The contents of this publication are presented for informational purposes only, and while every effort has been made to ensure their accuracy, they are not to be construed as warranties or guarantees, express or implied, regarding the products or services described herein or their use or applicability. All sales are governed by our terms and conditions, which are available upon request. We reserve the right to modify or improve the designs or specifications of such products at any time without notice.

Emerson Process Management

Marshalltown, Iowa 50158 USA
Sorocaba, 18087 Brazil
Chatham, Kent ME4 4QZ UK
Dubai, United Arab Emirates
Singapore 128461 Singapore

www.Fisher.com