

Fisher™ CL600 Control-Disk™ Valve

The Fisher CL600 Control-Disk valve provides outstanding performance in a wide range of pressure and temperature conditions.

The CL600 Control-Disk valve is available in a lugged or double flanged body design. A splined drive shaft can combine with a variety of spring-and-diaphragm or pneumatic piston actuators to make the Control-Disk valve a reliable control valve for a variety of throttling applications in the process industries.

The CL600 Control-Disk valve can be supplied with one of several dynamic seals (figure 1) that can be used in a variety of demanding applications. With the appropriate seal selection and materials of construction, the pressure-assisted seal helps provide excellent shutoff against the full ASME class pressure range for the CL600 Control-Disk valve.

Features

- **Equal percentage flow characteristic--** An equal percentage flow characteristic provides an improved throttling range comparable to that of a segmented ball valve. This improved capability allows you to control closer to the target set point, regardless of process disturbances, which results in a reduction in process variability.
- **Fire Safe Construction--** The CL600 Control-Disk valve has been fire tested per API 607, 6th edition with the Phoenix III seal. Standard construction requires 316 stainless steel chrome plated disk, graphite packing, metal bearings and S17400 H1025 SST or S20910 SST shaft. For information on fire tested valves, consult Fire-Tested Rotary Valves Bulletin 59.3:025 ([D103907X012](#)).
- **Excellent Shutoff Integrity--** The pressure-assisted seal design provides tight shutoff and permits the use of smaller, less expensive actuators in applications requiring full ASME B16.34 shutoff capabilities.



X0955-2

Lugged Style Fisher Control-Disk Valve



X1610

Double Flanged Style Fisher Control-Disk Valve

- **Excellent Emissions Capabilities--** The optional ENVIRO-SEAL™ packing systems are designed with very smooth shaft surfaces and live-loading to provide improved sealing, guiding, and loading force transmission. The seal of the ENVIRO-SEAL system can control emissions to below 100 ppm (parts per million).

Features (continued on 2)

- **Sour Service Capability**-- Trim and bolting materials are available for applications involving sour liquids and gases. These constructions comply with NACE MR0175-2002, MR0175-2003, MR0103, and MR0175 / ISO 15156.
- **Reliable Flange Gasketing Surface**-- Seal retainer screws are located so there is no interference with the sealing function of either flat sheet or spiral wound line flange gaskets.
- **True Bidirectional Shutoff Performance**-- A feature of the valve design is that the torque necessary to open and close the valve is the same regardless of the direction in which the differential pressure is applied.
- **Easy Installation**-- The valve body self-centers on the line flange bolts as a fast, accurate means of centering the valve in the pipeline.
- **Powder Paint as Standard**-- The Emerson Automation Solutions powder paint finish offers an excellent corrosion-resistant finish to all steel parts.
- **Shaft Retention**-- Redundant shaft retention provides added protection. The packing follower, anti-blowout ring, and shaft groove interact to hold the shaft securely in the valve body in NPS 3 through 10 (see figure 4). The NPS 12 through 24 utilize a stepped packing follower and stepped shaft to hold the shaft securely in the valve body.

Table of Contents

Features	1	Installation	4
Specifications	3	Pressure Drops	8
Standard Seal Configurations	4		

CL600 Control-Disk Valve Specifications and Materials

Table 1. Fisher CL600 Control-Disk Valve Specifications

Specifications	ASME
Valve Body Size	NPS 3, 4, 6, 8, 10, 12, 14, 16, 18, 20, 24
Pressure Rating	CL600 per ASME B16.34
Valve Body Materials	WCC or CF8M (std)
	LCC, CD3MN, M35-2, and CW2M
Disk Materials	CF8M (std), CD3MN, M35-2, and CW2M
Disk Edge Coating	Chrome Plate (std) Chrome Coat Chromium Carbide Coating
End Connections	Mates with RF Flanges per ASME B16.5 Optional construction mates with RTJ Flanges per ASME B16.5
Valve Body Style	Lugged (Single Flange), Lugged with drilled through flange holes, or Double Flange
Shaft Connection Style	NPS 3-24: Splined (std) NPS 3-12: Square NPS 14-24: Keyed
Face-to-Face Dimensions	Meets MSS SP68, API 609, ASME B16.10, and EN 558 standards; Double-Flange available upon request
Shutoff	Soft Seal: Class VI
	Metal Seal: Class IV, reverse direction only
	Phoenix III Seal: Class VI; reverse direction preferred, forward direction optional
	High Pressure Seal: Class VI, reverse direction only
Flow Direction	Standard (reverse flow) is with the flow into the shaft side of the disk
Flow Characteristic	Equal Percentage
Disk Rotation	Clockwise (CW) to close

Table 2. Materials (Other Valve Components)

Component	Material
Shafts and Pins	S17400 H1025
	S20910
	N07718
Anti-Blowout Ring (NPS 3-8 only)	N07718
Seal Ring	Soft: ETFE
	Metal: S21800
	Phoenix III: S20910/ETFE
	HPS: S21800 Nitrided
Bearings	PEEK, S31600 Nitrided, R30006 (Alloy 6)
Packing	PTFE/carbon-filled PTFE (standard), graphite die-molded ribbon, ENVIRO-SEAL PTFE packing, ENVIRO-SEAL graphite packing

Figure 1. Available Seal Configurations

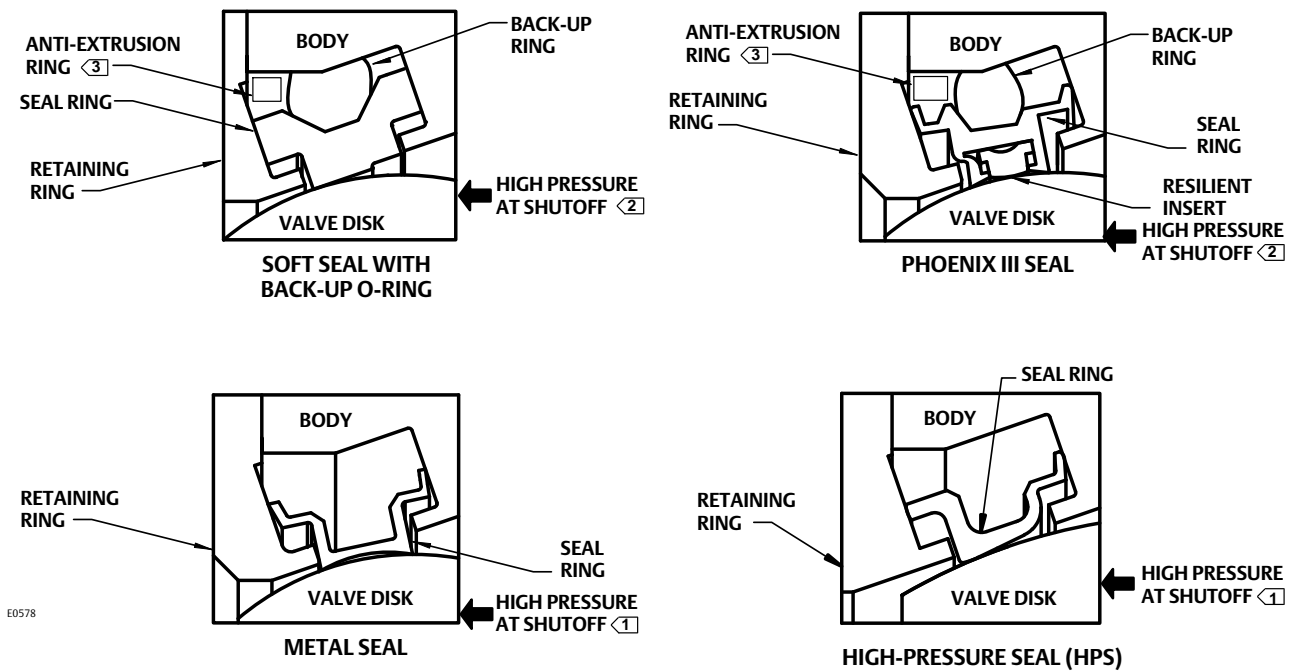

Notes:

- ① This unidirectional seal must be installed so that the retaining ring is downstream from the high pressure side of the valve at shutoff, as shown.
- ② For this bidirectional seal, the “preferred” valve orientation places the retaining ring downstream from the high pressure side of the valve at shutoff.
- ③ NPS 3 only.

Standard Seal Configurations

- **Standard Soft Seal**-- A resilient dynamic seal with an elastomeric back-up ring for low to moderate temperature applications.
- **Metal Seal**-- This stainless steel seal is available for severe service and high-temperature applications to 538°C (1000°F).
- **Phoenix III Seal**-- This three-component, metal-and-polymeric seal is available for severe service with low to moderate temperature applications.
- **High-Pressure Seal**-- This robust, stainless steel seal is available for severe service, cryogenic, and high-temperature applications to 538°C (1000°F).

Installation

Preferred valve orientation for the CL600 Control-Disk valve is reverse flow direction. Reverse flow direction is into the side of the valve body opposite the retaining ring or into the shaft side of the disk.

For erosive and many severe service applications, valves with bidirectional seals can and should be installed with the shaft horizontal and in the forward flow direction to prevent direct impingement of the process media on the seal, and to minimize the exposure of the shaft bearings to the process media.

The standard soft seal and the Phoenix III seal both offer bidirectional shutoff. Valves using either metal or HPS are unidirectional and must be installed in the reverse flow orientation.

For assistance in selecting the appropriate combination of actuator action and open valve position, consult your [Emerson sales office](#). Dimensions and weights are shown in figure 5 and table 6.

Figure 2. CL600 Control-Disk Valve, NPS 3 to 6, Valve Body Assembly

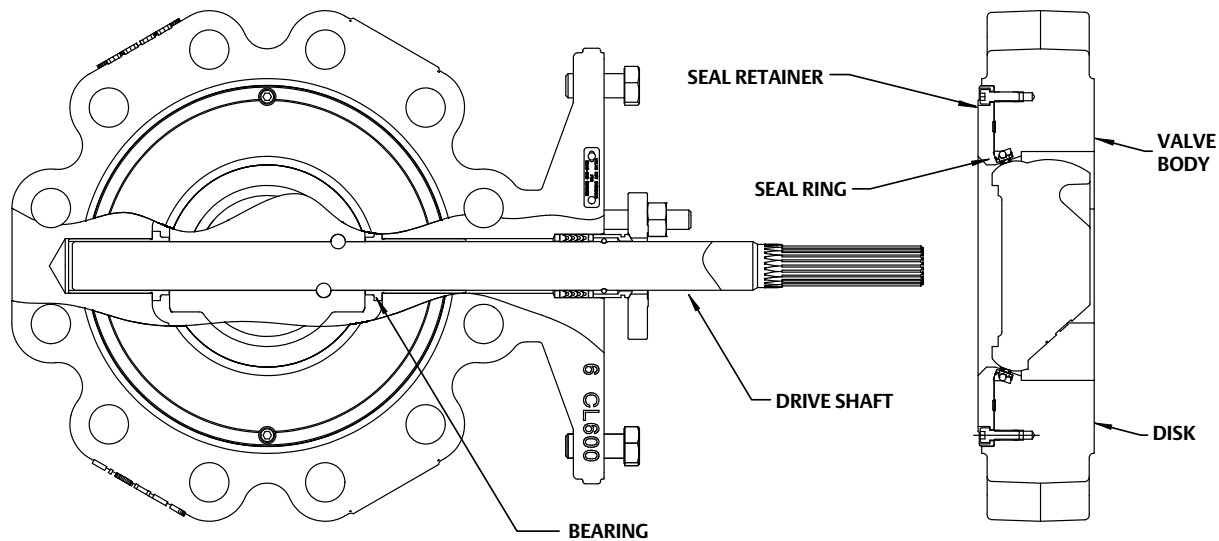

GE72464-D4

Figure 3. CL600 Control-Disk Valve, NPS 8 to 24, Valve Body Assembly 

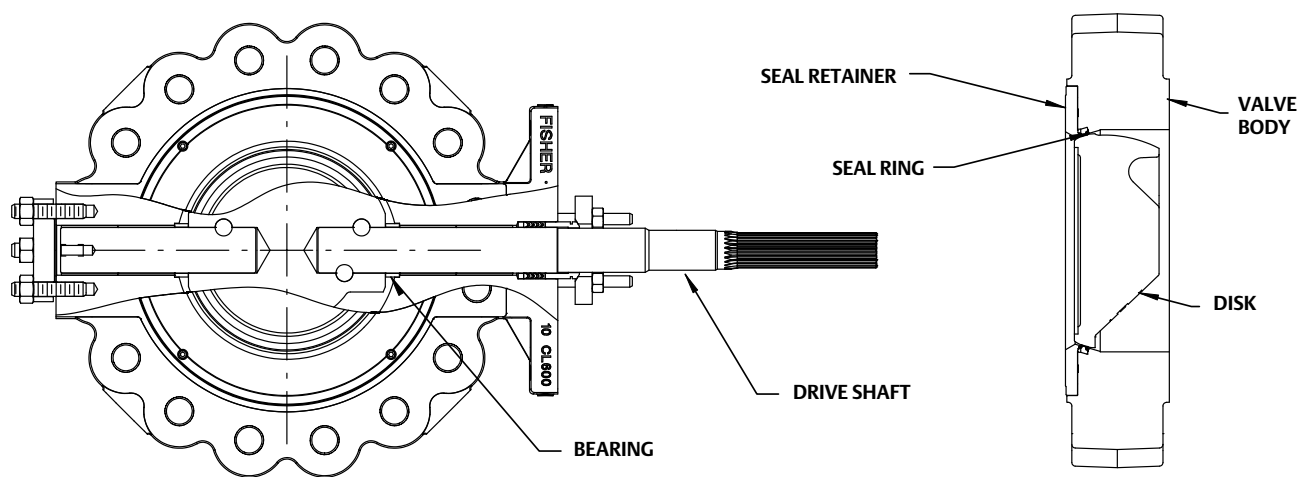

GE73029

Note:

 NPS 8 valve utilizes a one piece shaft

Table 3. Material Temperature Ranges

PART NAME	MATERIAL	TEMP °C	TEMP °F
Valve Body	WCC Steel	-29 to 427	-20 to 800
	CF8M ⁽¹⁾	-254 to 538	-425 to 1000
	LCC	-45 to 343	-50 to 650
	CD3MN	-51 to 316	-60 to 600
	M35-2	-198 to 482	-325 to 900
	CW2M ⁽¹⁾	-198 to 538	-325 to 1000
Disk	CF8M with Chrome Plated Disk Edge	-254 to 427	-425 to 800
	CF8M with Chrome Coated Disk Edge ⁽¹⁾	-254 to 538	-425 to 1000
	CF8M with Chromium Carbide Disk Edge ⁽¹⁾	-254 to 538	-425 to 1000
	CD3MN (no plating) ⁽²⁾	-51 to 316	-60 to 600
	M35-2 (no plating) ⁽²⁾	-198 to 482	-325 to 900
	CW2M (no plating) ⁽¹⁾⁽²⁾	-198 to 538	-325 to 1000
Shaft	S17400 (H1025)	-46 to 427	-50 to 800
	S20910 ⁽¹⁾	-198 to 538	-325 to 1000
	S31803	-51 to 316	-60 to 600
	N05500	-198 to 482	-325 to 900
	N10276	-198 to 538	-325 to 1000
	N07718 ⁽¹⁾	-254 to 538	-425 to 1000
Bearings	PEEK ⁽¹⁾	-73 to 149	-100 to 300
	S31600 Nitrided ⁽¹⁾	-254 to 538	-425 to 1000
	R30006 (Alloy 6) ⁽¹⁾	-198 to 538	-325 to 1000
Seal	ETFE Soft Seal Ring		
	ETFE Soft Seal Ring with FKM Backup Ring	-29 to 149	-20 to 300
	ETFE Soft Seal Ring with EPR Backup Ring	-54 to 149	-65 to 300
	S20910/ETFE Phoenix III Seal Ring		
	S20910/ETFE Phoenix III Seal Ring with FKM Backup Ring	-40 to 149	-40 to 300
	S20910/ETFE Phoenix III Seal Ring with EPR Backup Ring	-62 to 149	-80 to 300
	Metal Seal		
	S21800 ⁽¹⁾	-198 to 538	-325 to 1000
	S20910 ⁽¹⁾	-198 to 538	-325 to 1000
	High Pressure Seal		
	S21800 Nitrided ⁽¹⁾	-198 to 538	-325 to 1000
	S20910 Nitrided ⁽¹⁾	-198 to 538	-325 to 1000
Packing	PTFE /Carbon-filled PTFE (standard)	-45 to 232	-50 to 450
	ENVIRO-SEAL PTFE	-45 to 232	-50 to 450
	Graphite Die-molded Ribbon	-198 to 538	-325 to 1000
	ENVIRO-SEAL Graphite	-198 to 371	-325 to 700

1. The maximum temperature for a standard CL600 Control-Disk valve is 538°C (1000°F). Contact your [Emerson sales office](#) for use in higher temperature applications.
2. For use with soft seal only.

Figure 4. Anti-Blowout Protection

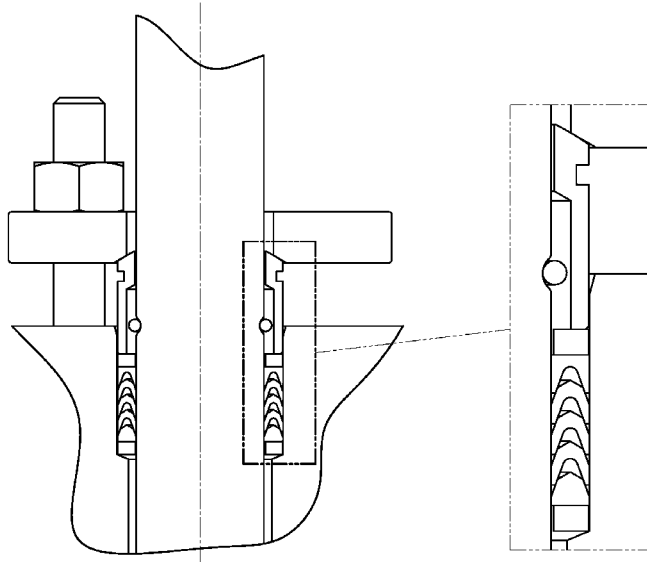

GE74781

NPS 3 THROUGH 8 WITH ANTI-BLOWOUT RING

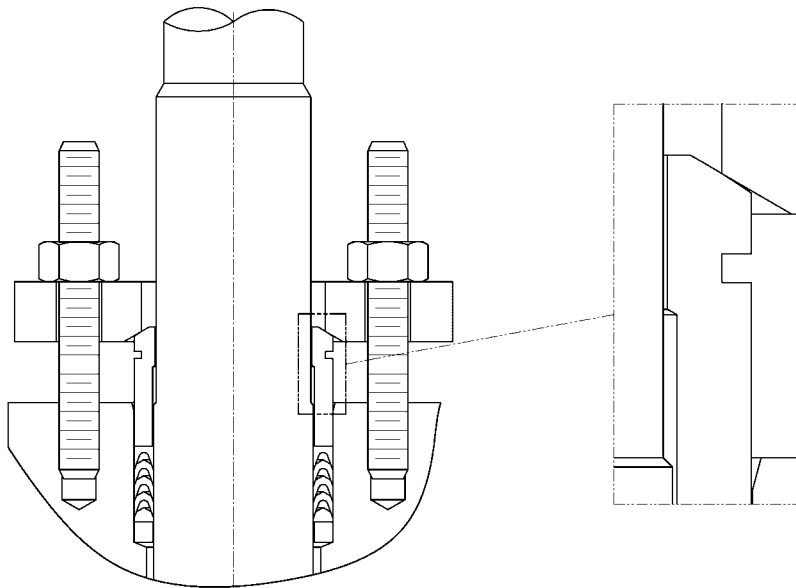

GE72841

NPS 10 THROUGH 24 WITH STEPPED SHAFT

Pressure Drops

Pressure drop limits of any given valve are based on valve body, and trim material limits. To find the appropriate pressure drop limitation, choose the desired valve size and temperature range. Then search

table 4 for body limitations and table 5 for trim limitations. Information on limits for CW2M, M35-2, and other alloy constructions can be obtained by contacting your [Emerson sales office](#). The lowest number from the tables is the appropriate limit. The tables for both trim and body limits must be consulted.

Table 4. Maximum Allowable Shutoff Pressure Drops (Valve Ratings) Based on Carbon Steel and Stainless Steel Valve Types⁽¹⁾ (The tables for both trim and body limits must be consulted)

TEMPERATURE RANGE	PRESSURE RANGE			
	CL600			
	WCC ⁽²⁾	CF8M ⁽²⁾	LCC ⁽²⁾	CD3MN
°C	Bar			
-254 to -29	---	99.3	---	103.4
-29 to 38	103.4	99.3	103.4	103.4
93	103.4	85.5	103.4	102.7
149	100.3	77.2	100.3	92
204	96.9	70.7	96.9	84.8
260	91.7	65.8	91.7	80
316	83.4	62.1	83.4	76.9
343	81.0	61.0	81.0	---
371	76.5	60.0	---	---
399	70.0	59.0	---	---
427	56.9	58.3	---	---
454	---	57.6	---	---
482	---	57.2	---	---
510	---	53.4	---	---
538	---	50.0	---	---
°F	Psi			
-425 to -20	---	1440	---	1500
-20 to 100	1500	1440	1500	1500
200	1500	1240	1500	1490
300	1455	1120	1455	1335
400	1405	1025	1405	1230
500	1330	955	1330	1160
600	1210	900	1210	1115
650	1175	885	1175	---
700	1110	870	---	---
750	1015	855	---	---
800	825	845	---	---
850	---	835	---	---
900	---	830	---	---
950	---	775	---	---
1000	---	725	---	---

1. For pressure/temperature rating of other materials, contact your Emerson sales office.
2. WCC, LCC, and CF8M valve bodies use 531600 seal retainers and blind flanges.

Table 5. Maximum Allowable Shutoff Pressure Drops based on Trim⁽¹⁾

Note: Do not exceed the ASME pressure/temperature ratings of the valve or mating flanges.

Trim	Temperature, °C	NPS											
		3	4	6	8	10	12	14	16	18	20	24	
		Bar											
ETFE Seal, PEEK Bearings	-46 to 37	103	94	103	103	103	102	103	103	103	103	103	100
	93	76	76	76	76	76	76	76	76	76	76	76	76
	121	41	41	41	41	41	41	41	41	41	41	41	41
	149	7	7	7	7	7	7	7	7	7	7	7	7
Phoenix III Seal, PEEK Bearings	-46 to 37	103	92	103	103	103	81	103	102	103	103	103	80
	93	103	86	103	101	103	73	103	92	103	103	103	72
	121	61	61	61	61	61	61	61	61	61	61	61	61
	149	21	21	21	21	21	21	21	21	21	21	21	21
Phoenix III Seal, Metal Bearings	-46 to 37	103	90	103	103	103	63	103	78	103	103	103	61
	93	98	84	103	99	96	56	103	71	103	101	103	56
	121	61	61	61	61	61	54	61	61	61	61	61	54
	149	21	21	21	21	21	21	21	21	21	21	21	21
Metal Seal, PEEK Bearings	-46 to 37	103	92	103	103	103	86	103	103	103	103	103	91
	149	100	83	100	97	100	73	100	95	100	100	100	79
Metal Seal, Metal Bearings	-46 to 37	103	90	103	103	103	66	103	84	103	103	103	69
	316	83	75	83	78	81	49	83	65	83	83	83	54
	427 ⁽²⁾	70	70	70	70	70	47	70	62	70	70	70	51
HPS Seal, Metal Bearings	-46 to 37	33	44	89	80	89	57	103	77	103	103	103	67
	316	18	28	67	59	68	43	83	60	83	83	83	52
	427 ⁽²⁾	16	26	63	56	64	41	70	57	70	70	70	50
Trim	Temperature, °F	PSI											
ETFE Seal, PEEK Bearings	-50 to 100	1500	1370	1500	1500	1500	1483	1500	1500	1500	1500	1500	1456
	200	1100	1100	1100	1100	1100	1100	1100	1100	1100	1100	1100	1100
	250	600	600	600	600	600	600	600	600	600	600	600	600
	300	100	100	100	100	100	100	100	100	100	100	100	100
Phoenix III Seal, PEEK Bearings	-50 to 100	1500	1332	1500	1500	1500	1175	1500	1476	1500	1500	1500	1155
	200	1500	1251	1500	1464	1500	1058	1500	1340	1500	1500	1500	1051
	250	890	890	890	890	890	890	890	890	890	890	890	890
	300	300	300	300	300	300	300	300	300	300	300	300	300
Phoenix III Seal, Metal Bearings	-50 to 100	1500	1303	1500	1500	1500	907	1500	1134	1500	1500	1500	887
	200	1428	1222	1500	1435	1394	817	1496	1030	1500	1463	1500	807
	250	890	890	890	890	890	788	890	890	890	890	890	781
	300	300	300	300	300	300	300	300	300	300	300	300	300
Metal Seal, PEEK Bearings	-50 to 100	1500	1336	1500	1500	1500	1245	1500	1500	1500	1500	1500	1327
	300	1455	1207	1455	1407	1455	1053	1455	1381	1455	1455	1455	1147
Metal Seal, Metal Bearings	-50 to 100	1500	1309	1500	1500	1500	954	1500	1221	1500	1500	1500	998
	600	1210	1093	1210	1127	1176	714	1210	939	1210	1210	1210	777
	800 ⁽²⁾	1015	1015	1015	1015	1015	675	1015	894	1015	1015	1015	741
HPS Seal, Metal Bearings	-50 to 100	484	640	1284	1154	1289	831	1500	1124	1500	1500	1500	978
	600	264	408	968	862	981	624	1210	865	1210	1210	1210	760
	800 ⁽²⁾	228	370	916	815	932	590	1015	823	1015	1015	1015	725

1. Trim ratings based on S17400 H1025 shaft. For other shaft materials, please contact factory.
2. The temperature limit of S17400 H1025 shaft material is 427°C (800°F). For higher temperatures another shaft material option must be selected.

Table 6. Single Flange Dimensions and Weights

Valve Size, NPS	A	E	F	G	K	R	S ⁽¹⁾	T	U	γ ⁽²⁾	W ⁽²⁾	Approximate Weight
	mm											kg
3	52	187	198	98	123	127	15.9	117	--	3/4-10	1/2-13	10.8
4	62	214	259	128	150	157	19.1	152	32	7/8-9	1/2-13	21.6
6	76	208	333	166	220	216	31.8	235	46	1-8	5/8-11	45.9
8	102	208	407	241	234	270	38.1	235	46	1-1/8-8	5/8-11	81.5
10	116	356	506	312	302	324	44.5	273	51	1-1/4-8	3/4-10	160
12	140	356	553	339	332	381	50.8	273	51	1-3/8-8	3/4-10	217
14	157	356	597	370	348	413	63.5	337	76	1-1/2-8	7/8-9	287
16	178	356	678	408	386	470	63.5	337	76	1-5/8-8	7/8-9	405
18	198	508	735	451	427	533	76.2	533	127	1-5/8-8	1-1/4-8	577
20	216	508	807	478	446	584	76.2	533	127	1-5/8-8	1-1/4-8	739
24	230	508	933	544	513	692	76.2	533	127	1-7/8-8	1-1/4-8	1036
	Inches											lbs
3	2.04	7.38	7.80	3.85	4.84	5.00	0.63	4.62	--	3/4-10	1/2-13	24
4	2.44	8.44	10.20	5.04	5.89	6.19	0.75	6.00	1.25	7/8-9	1/2-13	48
6	2.98	8.19	13.11	6.54	8.65	8.50	1.25	9.25	1.81	1-8	5/8-11	102
8	4.00	8.19	16.02	9.49	9.20	10.62	1.50	9.25	1.81	1-1/8-8	5/8-11	181
10	4.56	14.00	19.92	12.28	11.90	12.75	1.75	10.75	2.00	1-1/4-8	3/4-10	355
12	5.51	14.00	21.77	13.35	13.07	15.00	2.00	10.75	2.00	1-3/8-8	3/4-10	482
14	6.18	14.00	23.50	14.57	13.70	16.25	2.50	13.25	3.00	1-1/2-8	7/8-9	637
16	7.00	14.00	26.69	16.06	15.20	18.50	2.50	13.25	3.00	1-5/8-8	7/8-9	900
18	7.81	20.00	28.94	17.76	16.81	21.00	3.00	21.00	5.00	1-5/8-8	1-1/4-8	1280
20	8.50	20.00	31.77	18.82	17.57	23.00	3.00	21.00	5.00	1-5/8-8	1-1/4-8	1640
24	9.06	20.00	36.73	21.42	20.20	27.25	3.00	21.00	5.00	1-7/8-8	1-1/4-8	2300

1. This is the nominal valve shaft diameter to be used when selecting Fisher actuators.
 2. Threaded hole per ASME B1.1.

Figure 5. Single Flange Dimensions (also see table 6)

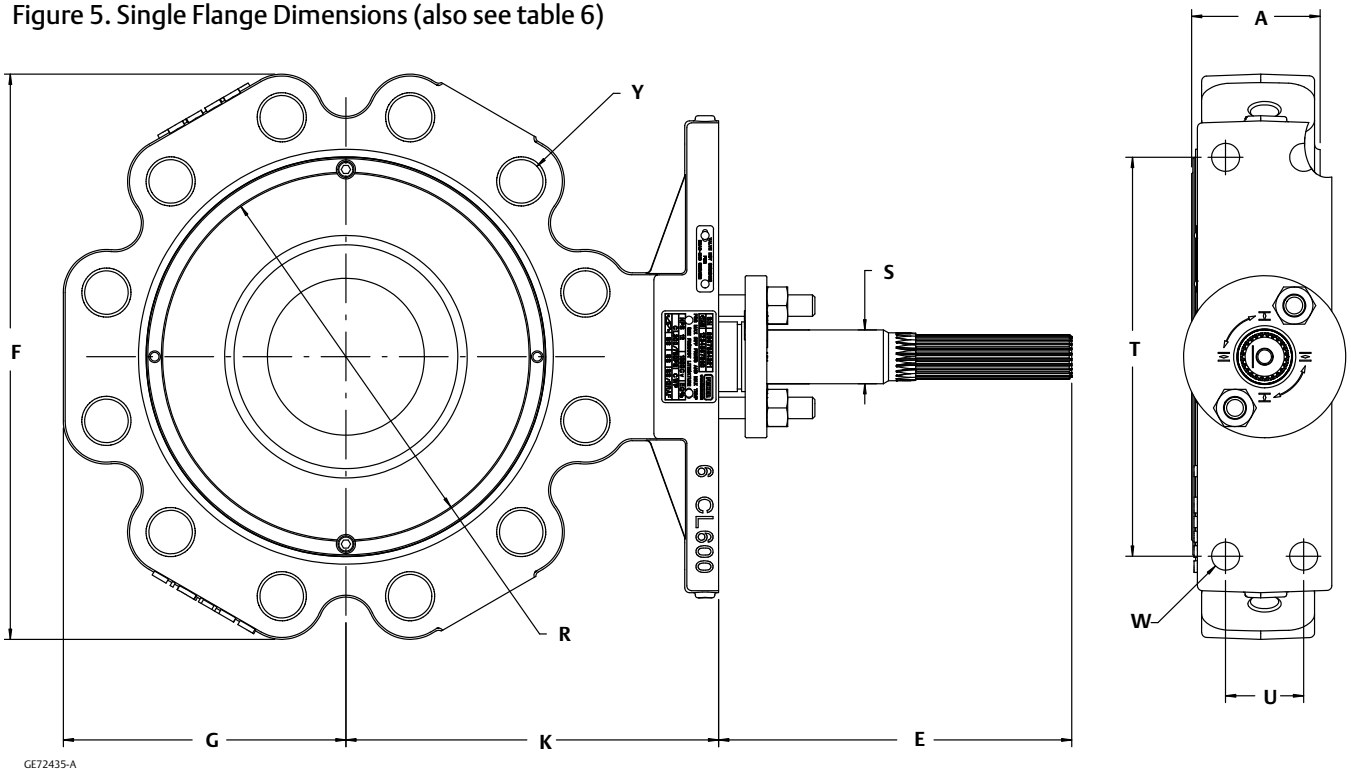

Table 7. Double Flange Dimensions and Weights

Valve Size, NPS	A	E	F	G	H	K	R	S ⁽¹⁾	T	U	Y ⁽²⁾	W ⁽²⁾	Approximate Weight
	mm												kg
3	180	187	211	106	21.5	123	127	15.9	117	---	3/4-10	1/2-13	25.9
4	190	214	277	138	25.6	150	157	19.1	152	32	7/8-9	1/2-13	48.1
6	210	208	357	178	28.4	220	216	31.8	235	46	1-8	5/8-11	97.1
8	230	208	423	243	31.9	234	270	38.1	235	46	1-1/8-8	5/8-11	145.6
10	250	356	515	316	35.1	302	324	44.5	273	51	1-1/4-8	3/4-10	247.7
12	270	356	563	343	35.1	332	381	50.8	273	51	1-1/4-8	3/4-10	316.6
14	290	356	610	374	38.3	348	413	63.5	337	76	1-3/8-8	7/8-9	410
16	310	356	691	412	41.5	386	470	63.5	337	76	1-1/2-8	7/8-9	571.5
18	330	508	751	455	43.7	428	533	76.2	533	127	1-5/8-8	1-1/4-8	817.4
20	350	508	831	483	44.6	446	584	76.2	533	76	1-5/8-8	1-1/4-8	989.3
24	390	508	946	549	50.8	543	692	76.2	533	127	1-7/8-8	1-1/4-8	1422
	Inches												lbs
3	7.09	7.38	.32	4.16	0.85	4.84	5.00	0.63	4.62	---	3/4-10	1/2-13	57
4	7.48	8.44	.89	5.45	1.01	5.89	6.19	0.75	6.00	1.25	7/8-9	1/2-13	106
6	8.27	8.19	.04	7.02	1.12	8.65	8.50	1.25	9.25	1.81	1-8	5/8-11	214
8	9.06	8.19	.65	9.56	1.26	9.20	10.62	1.50	9.25	1.81	1-1/8-8	5/8-11	321
10	9.84	14.00	.28	12.42	1.38	11.90	12.75	1.75	10.75	2.00	1-1/4-8	3/4-10	546
12	10.63	14.00	.15	13.50	1.38	13.07	15.00	2.00	10.75	2.00	1-1/4-8	3/4-10	698
14	11.42	14.00	.00	14.71	1.51	13.70	16.25	2.50	13.25	3.00	1-3/8-8	7/8-9	904
16	12.2	14.00	.19	16.21	1.63	15.20	18.50	2.50	13.25	3.00	1-1/2-8	7/8-9	1260
18	12.99	20.00	.55	17.93	1.72	16.81	21.00	3.00	21.00	5.00	1-5/8-8	1-1/4-8	1802
20	13.78	20.00	.70	19.00	1.76	17.57	23.00	3.00	21.00	3.00	1-5/8-8	1-1/4-8	2181
24	15.35	20.00	.24	21.62	2.00	20.20	27.25	3.00	21.00	5.00	1-7/8-8	1-1/4-8	3135

Figure 6. Double Flange Dimensions (also see table 7)

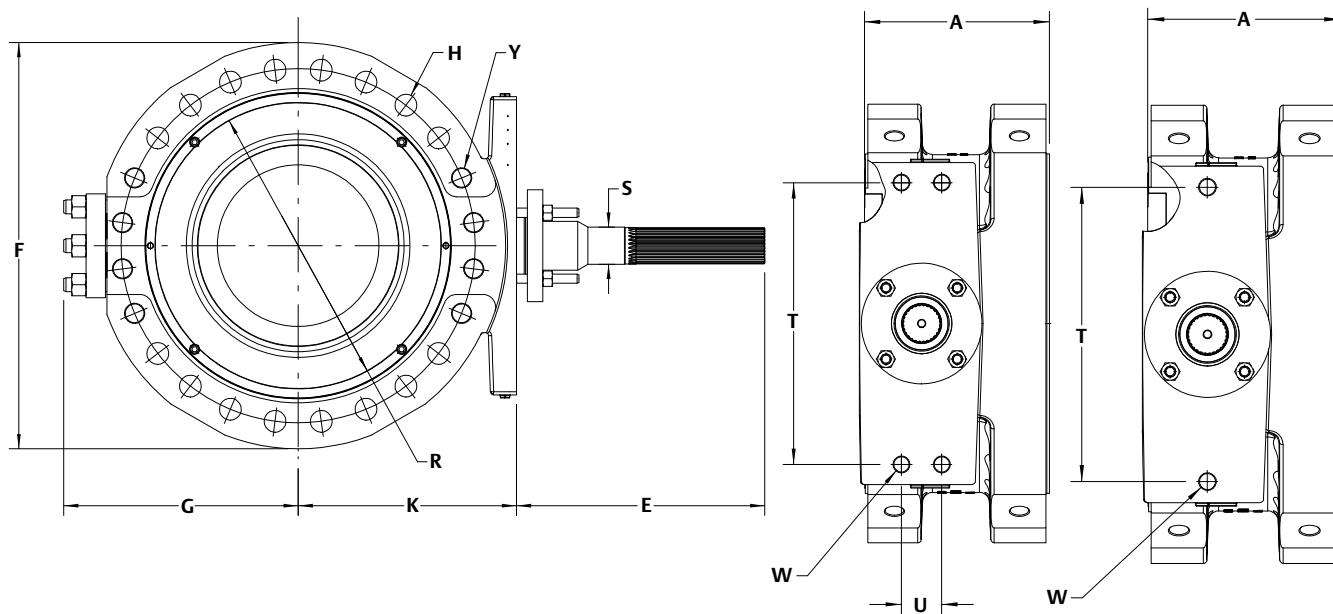
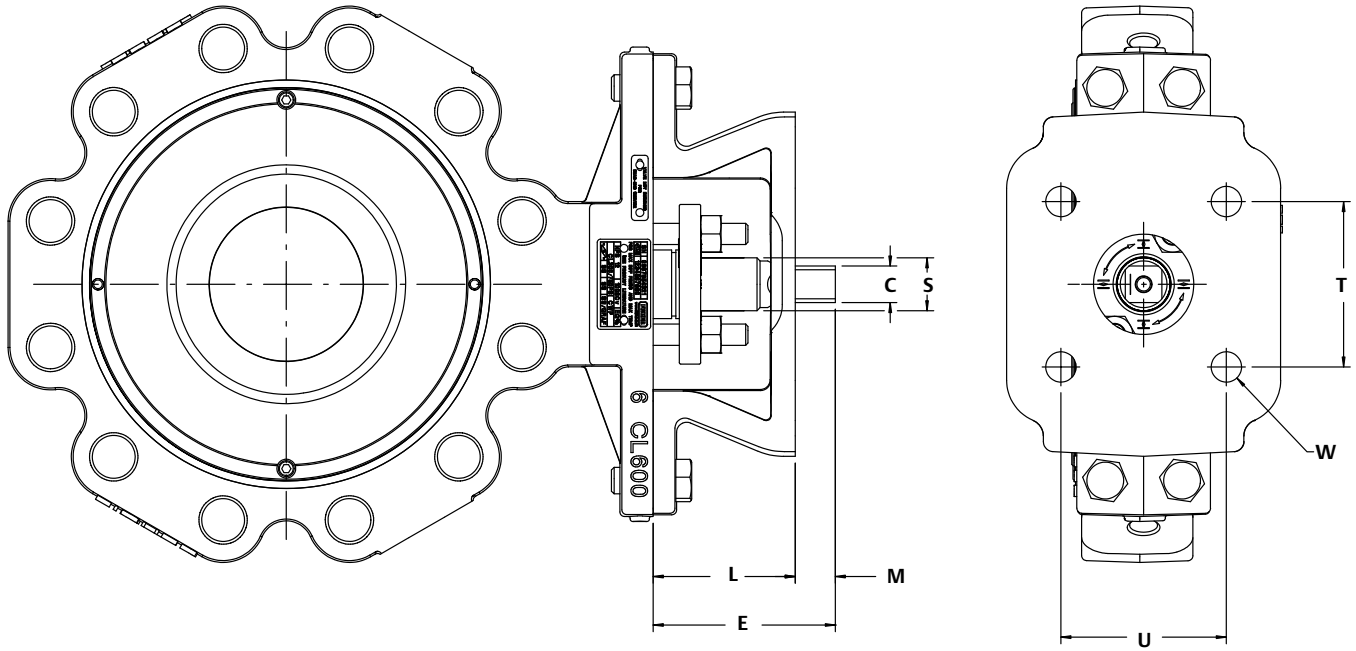

Table 8. Dimensions, Optional Square Shaft and Mounting Bracket (ISO 5211)

Valve Size, NPS	C	E	L	M	S	T	U	W	ISO 5211
	mm								
3	11	76	64	12	15.9	49.5	49.5	10	F07
						72.1	72.1	12	F10
4	14	103	87	16	19.1	49.5	49.5	10	F07
						72.1	72.1	12	F10
						88.4	88.4	14	F12
6	22	108	85	23	31.8	72.1	72.1	12	F10
						88.4	88.4	14	F12
						99	99	18	F14
						116.7	116.7	22	F16
8	27	114	85	29	38.1	72.1	72.1	12	F10
						88.4	88.4	14	F12
						99	99	18	F14
						116.7	116.7	22	F16
10	36	190	152	38	44.5	99	99	18	F14
						116.7	116.7	22	F16
12	36	190	152	38	50.8	99	99	18	F14
						116.7	116.7	22	F16
Inches									
3	0.43	3.00	2.52	0.48	0.63	1.95	1.95	0.39	F07
						2.84	2.84	0.47	F10
4	0.55	4.06	3.43	0.63	0.75	1.95	1.95	0.39	F07
						2.84	2.84	0.47	F10
						3.48	3.48	0.55	F12
6	0.87	4.25	3.35	0.90	1.25	2.84	2.84	0.47	F10
						3.48	3.48	0.55	F12
						3.90	3.90	0.71	F14
						4.59	4.59	0.87	F16
8	1.06	4.49	3.35	1.14	1.50	2.84	2.84	0.47	F10
						3.48	3.48	0.55	F12
						3.90	3.90	0.71	F14
						4.59	4.59	0.87	F16
10	1.42	7.48	6	1.50	1.75	3.90	3.90	0.71	F14
						4.59	4.59	0.87	F16
12	1.42	7.48	6	1.50	2.00	3.90	3.90	0.71	F14
						4.59	4.59	0.87	F16

Figure 7. CL600 Control-Disk Valve Assembly with Square Shaft and Mounting Bracket (also see table 8)



GE72199-A

Table 9. Dimensions, Optional Keyed Shaft

Valve Size, NPS	C	D1	D2	E	R
	mm				
14	12.7	297	309	95.3	57.2
16	16.0	316	330	114.3	69.9
18	16.0	394	408	114.3	69.9
20	16.0	394	408	114.3	69.9
24	16.0	394	408	114.3	69.9
Inches					
14	0.50	11.68	12.2	3.75	2.25
16	0.63	12.44	13.0	4.5	2.75
18	0.63	15.51	16.1	4.5	2.75
20	0.63	15.51	16.1	4.5	2.75
24	0.63	15.51	16.1	4.5	2.75

Figure 8. Dimensions for Fisher CL600 Control-Disk NPS 14 to 24 Valve with Keyed Shaft

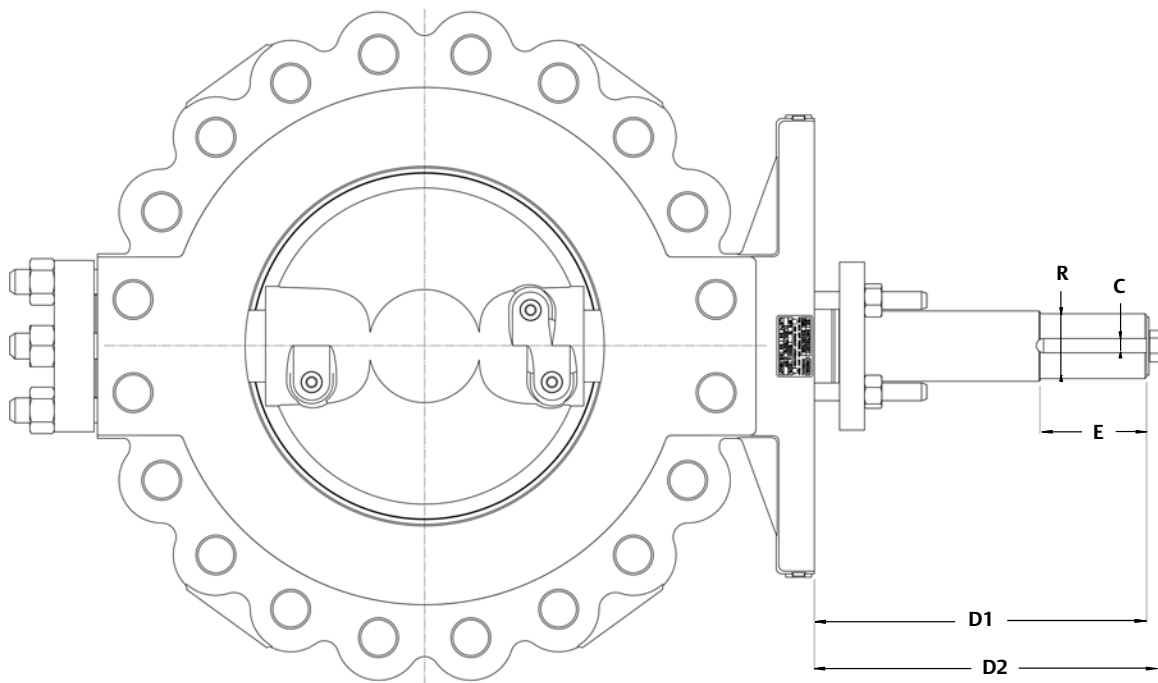

GE72443-A

Neither Emerson, Emerson Automation Solutions, nor any of their affiliated entities assumes responsibility for the selection, use or maintenance of any product. Responsibility for proper selection, use, and maintenance of any product remains solely with the purchaser and end user.

Fisher, Control-Disk, and ENVIRO-SEAL are marks owned by one of the companies in the Emerson Automation Solutions business unit of Emerson Electric Co. Emerson Automation Solutions, Emerson, and the Emerson logo are trademarks and service marks of Emerson Electric Co. All other marks are the property of their respective owners.

The contents of this publication are presented for informational purposes only, and while every effort has been made to ensure their accuracy, they are not to be construed as warranties or guarantees, express or implied, regarding the products or services described herein or their use or applicability. All sales are governed by our terms and conditions, which are available upon request. We reserve the right to modify or improve the designs or specifications of such products at any time without notice.

Emerson Automation Solutions
Marshalltown, Iowa 50158 USA
Sorocaba, 18087 Brazil
Cernay, 68700 France
Dubai, United Arab Emirates
Singapore 128461 Singapore

www.Fisher.com

