

Fisher™ 4194H Differential Pressure Indicating Controllers

Fisher 4194H differential pressure indicating controllers show process differential pressure and set point on an easy-to-read process scale. These high static pressure controllers sense two different pressures and compare the difference between these pressures with an operator-adjusted set point. A pneumatic signal is then delivered to a control element to change the process differential pressure toward the set point. 4194H controllers use a differential pressure unit such as the Barton™ 199 for differential pressure up to 5.2 bar (75 psi). The product line includes proportional-only, proportional-plus-reset, and differential gap controllers.

The controllers are also available with anti-reset windup, internal auto/manual station, and remote set point adjustability (see table 1). 4194H controllers are used throughout industries where process monitoring and accurate measurement of differential pressure are required.

Features

- **Easy Maintenance**—Simple design of the controller allows fast, easy maintenance and minimal spare parts inventory.
- **Easy Adjustment**—Adjustments of set point and zero and span of the process pointer, and switching between direct and reverse action are accomplished quickly and without special tools. Also, the set point and proportional band can be adjusted with no interaction between the two adjustments.
- **Highly Visible Display**—Two red pointers on a 114 mm (4.50 inch) long white-on-black scale show differential pressure and deviation from set point at a glance. Two other gauges monitor supply and output pressures.
- **Low Air/Gas Consumption**—The relay and nozzle design reduces the steady-state consumption rate to as low as 0.07 m³/hr (2.5 scfh); less than the 6 scfh requirement set for the oil and gas industry by the US Environmental Protection Agency (New Source Performance Standards Subpart OOOO, EPA-HQ-QAR-2010-0505).
- **Corrosion Resistant**—Thermoplastic housing withstands a broad range of corrosive environments. Internal constructions are available to resist a corrosive supply pressure media.



CONTROLLER WITH DIFFERENTIAL PRESSURE UNIT

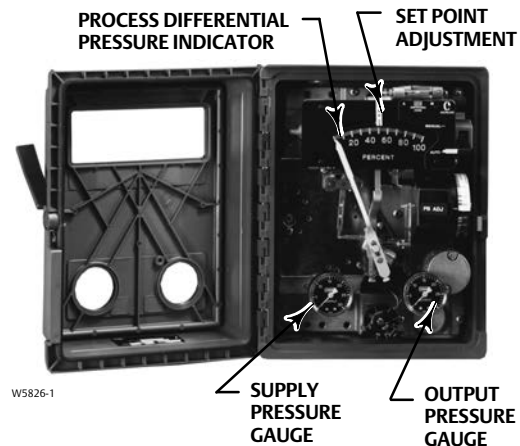

INTERIOR OF CONTROLLER

Specifications

Available Configurations

See table 1

Sensing Element Range (Input Signal)

See table 2

Process Scale

■ Linear, ■ square root, or ■ others on request⁽¹⁾

Process Connections

Standard: 1/4 NPT internal stainless steel
(all input ranges)

Optional: 1/2 NPT external stainless steel

Output Signal

Proportional or Proportional-Plus-Reset Range:

- 0.2 to 1.0 bar (3 to 15 psig) or
- 0.4 to 2.0 bar (6 to 30 psig)

Differential Gap Output:

- 0 and 1.4 bar (0 and 20 psig) or
- 0 and 2.4 bar (0 and 35 psig)

Action: Field-reversible between ■ direct (increasing sensed pressure increases output pressure) or ■ reverse (increasing sensed pressure decreases output pressure)

Supply and Output Connections

1/4 NPT internal

Supply Pressure Requirements⁽²⁾

See table 4

Supply Pressure Medium

Air or non-corrosive Natural Gas

Remote Set Point Pressures

- 0.2 to 1.0 bar (3 to 15 psig) or
- 0.4 to 2.0 bar (6 to 30 psig)

Construction Materials

See table 3

Controller Adjustments

Proportional Band: 5 to 500% of process scale range

Reset: Adjustable from 0.01 to more than 74 min per repeat (from 100 to less than 0.0135 repeats per min)

Differential Gap Controllers: Adjustable from 1 to 100% of process scale range

Set Point: Continuously adjustable from 0 to 100% of the scale range

Controller Performance⁽³⁾

Repeatability: 0.4% of process scale range

Dead Band: Less than 0.2% of process scale range

Steady-State Air Consumption⁽⁴⁾⁽⁵⁾

0.2 to 1.0 bar (3 to 15 psig) Output:
0.08 m³/hr (2.8 scfh)

0.4 to 2.0 bar (6 to 30 psig) Output:
0.07 m³/hr (2.5 scfh)

Operative Ambient Temperature Limits⁽²⁾⁽⁶⁾

-40 to 70°C (-40 to 160°F)

(continued)

Table of Contents

Features 1

Construction Features 7

Principle of Operation 5

 4194H Controllers 5

 Auto/Manual Option 6





Installation 9

Ordering Information 10

 Applications 10

 Construction 10

Specifications (continued)

<p>Hazardous Area Classification</p> <p>Complies with the requirements of ATEX Group II Category 2 Gas and Dust</p> <p>  II 2 G D Ex h IIC Tx Gb Ex h IIIC Tx Db</p> <p>Maximum surface temperature (Tx) depends on operating conditions</p> <p>Gas: T6 Dust: T70</p> <p>Meets Customs Union technical regulation TP TC 012/2011 for Groups II/III Category 2 equipment</p> <p> II Gb c T*X III Db c T*X </p>	<p>Housing</p> <p>Designed to NEMA 3 (Weatherproof) and IEC 529 IP54 Specifications</p> <p>Mounting</p> <p>Controller is mounted on a pipestand</p> <p>Approximate Weight</p> <p>Controller: 4.5 kg (10 lb) without the differential pressure unit</p> <p>Differential Pressure Unit: 21.5 kg (47 lb)</p> <p>Total Weight (controller and differential pressure unit): 26 kg (57 lb) (with a Barton 199 Differential Pressure Unit)</p>
--	--

NOTE: Specialized instrument terms are defined in ANSI/ISA Standard 51.1 - Process Instrument Terminology.
 1. Consult your [Emerson sales office](#) for additional information.
 2. The pressure/temperature limits in this document and any applicable standard or code limitation for valve should not be exceeded.
 3. With Barton 199 differential pressure unit.
 4. Normal m³/hr--normal cubic meters per hour (m³/hr, 0°C and 1.01325 bar, absolute). Scfh--standard cubic feet per hour (ft³/hr, at 60°F and 14.7 psig).
 5. Without auto/manual switch. With auto/manual switch, add 0.01 m³/hr (0.5 scfh)
 6. Also for transportation and storage limits.

Table 1. Available Configurations

TYPE NUMBER(1)	CONFIGURATIONS						
	Proportional-Only	Proportional-Plus Reset	Proportional-Plus Reset-Plus-Rate(2)	Differential Gap	Anti-Reset Windup	Remote Set Point	Internal Auto/Manual Station
4194HA	X	---	---	---	---	---	---
4194HAE	X	---	---	---	---	---	X
4194HAM	X	---	---	---	---	X	---
4194HAME	X	---	---	---	---	X	X
4194HB	---	X	---	---	---	---	---
4194HBE	---	X	---	---	---	---	X
4194HBF	---	X	---	---	X	---	---
4194HBFE	---	X	---	---	X	---	X
4194HBM	---	X	---	---	---	X	---
4194HBME	---	X	---	---	---	X	X
4194HBFM	---	X	---	---	X	X	---
4194HBFME	---	X	---	---	X	X	X
4194HC	---	---	X	---	---	---	---
4194HCE	---	---	X	---	---	---	X
4194HCF	---	---	X	---	X	---	---
4194HCFE	---	---	X	---	X	---	X
4194HCM	---	---	X	---	---	X	---
4194HCME	---	---	X	---	---	X	X
4194HCFM	---	---	X	---	X	X	---
4194HCFME	---	---	X	---	X	X	X
4194HS	---	---	---	X	---	---	---
4194HSE	---	---	---	X	---	---	X
4914HSM	---	---	---	X	---	X	---
4194HSME	---	---	---	X	---	X	X

1. Reverse-acting constructions are designated by an R added to the type number.
 2. Consult your Emerson sales office for information on rate.

Table 2. Process Sensor (Barton 199) Ranges and Pressure Ratings

AVAILABLE DIFFERENTIAL PRESSURE UNIT OPERATING RANGES		STATIC PRESSURE OPERATING RANGE	
mbar	Inch wc	Bar	Psig
0 to 50	0 to 20	---(1)	---(1)
0 to 63	0 to 25		
0 to 125	0 to 50		
0 to 188	0 to 75		
0 to 250	0 to 100		
Bar	Psi		
0 to 1.0	0 to 15		
0 to 3.4	0 to 50		
0 to 5.2	0 to 75		

1. Available in ranges of 0 to 70 bar (0 to 1000 psig), 0 to 172 bar (0 to 2500 psig), and 0 to 413 bar (0 to 6000 psig). Actual static pressure depends on differential pressure unit rating and materials.

Table 3. Construction Materials

Product	Part	Standard Material	Optional Material
4194H Controllers	Case and cover	Polyester plastic	---
	Exterior tubing	Copper	Aluminum, stainless steel, steel, polyethylene
	Exterior fittings	C36000 (brass)	Aluminum, stainless steel, steel, polyethylene
	Interior tubing	Copper	S30400 (304 stainless steel)
	Nozzle	S30300 (303 stainless steel)	---
	Flapper	S31600 (316 stainless steel)	---
	Relay springs	S30200 (302 stainless steel), steel	---
	Relay O-rings	Nitrile	---
	Relay diaphragms	Nitrile	---
	Other relay metal parts	Aluminum, stainless steel	---
	Feedback bellows assembly	C51000 (bronze)	S32100 (321 stainless steel)
	Supply and output gauges	Brass (wetted parts only)	Stainless steel (wetted parts only)
	Remote set point bellows	N09902 (nickel alloy)	---
Barton 199 Differential Pressure Unit	Mounting plates	Zinc-plated steel	---
	Bellows	Stainless steel	---
	Housing	Steel	Stainless steel

Table 4. Supply Pressure Data

Output Signal Range		Normal Operating Supply Pressure ⁽¹⁾	Maximum Pressure to Prevent Internal Damage ⁽²⁾
Bar	0.2 to 1.0 or 0 and 1.4 (differential gap)	1.4	3.4
	0.4 to 2.0 or 0 and 2.4 (differential gap)	2.4	3.4
Psig	3 to 15 or 0 and 20 (differential gap)	20	50
	6 to 30 or 0 and 35 (differential gap)	35	50

1. If this pressure is exceeded, control stability may be impaired.
2. If this pressure is exceeded, damage to the controller may result.

Figure 1. Operational Schematic of Fisher 4194H Differential Pressure Controllers

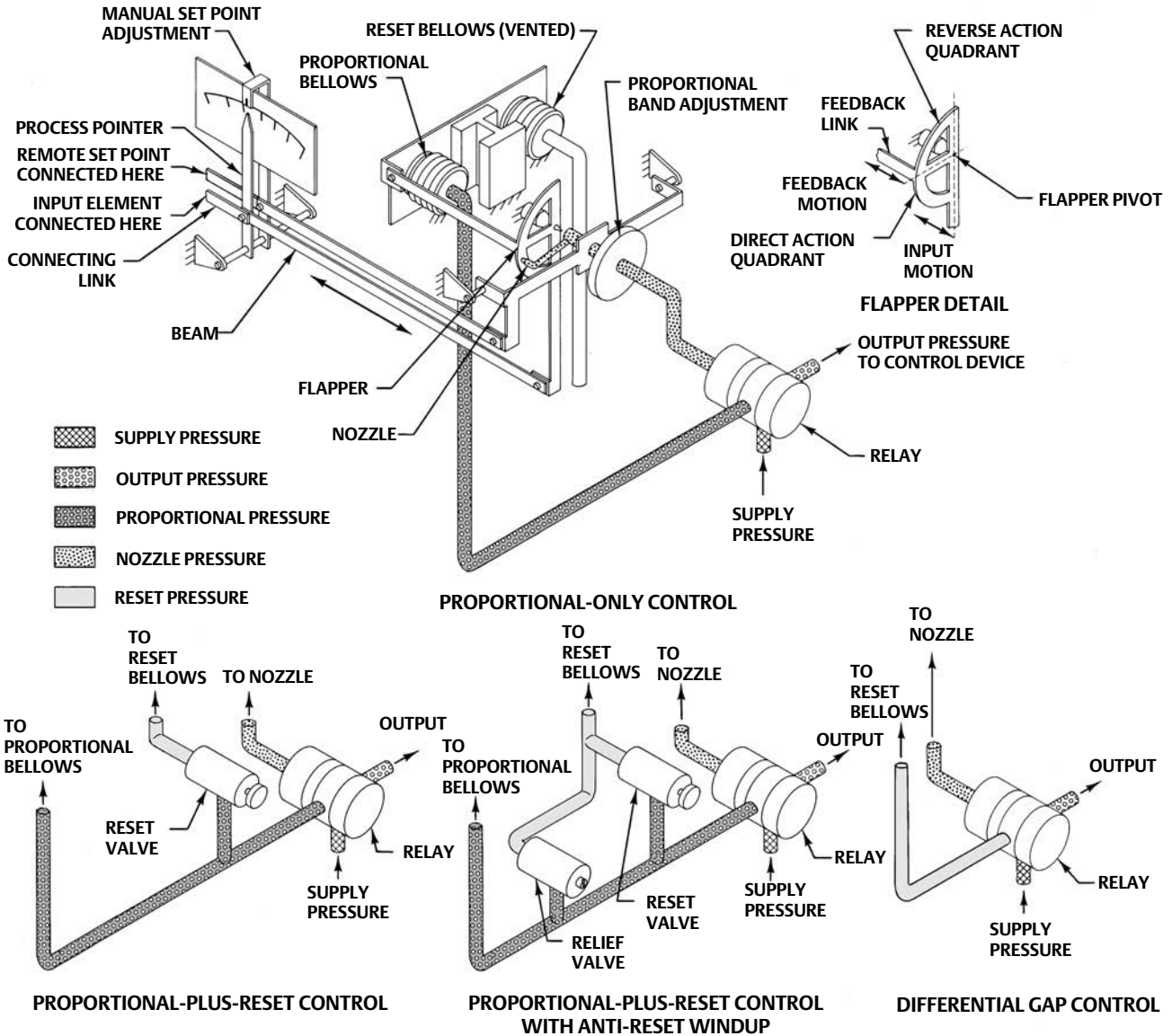

C0742

Principle of Operation

4194H Controllers

Refer to the proportional-only control diagram in figure 1. The input element is connected to the process pointer and flapper by a connecting linkage.

As the process differential pressure increases in a direct-acting controller, the flapper moves toward the

nozzle, restricting flow through the nozzle and increasing nozzle pressure. When this occurs, relay action increases the output pressure (delivery) of the controller. Output pressure is fed back to the proportional bellows. The action of the proportional bellows counters the flapper movement that resulted from the process differential pressure change, and backs the flapper away from the nozzle. Set point adjustment also changes the proximity of the nozzle and flapper; however, when the set point is changed, the nozzle moves with respect to the flapper. When

Figure 2. Schematic of Auto/Manual Option

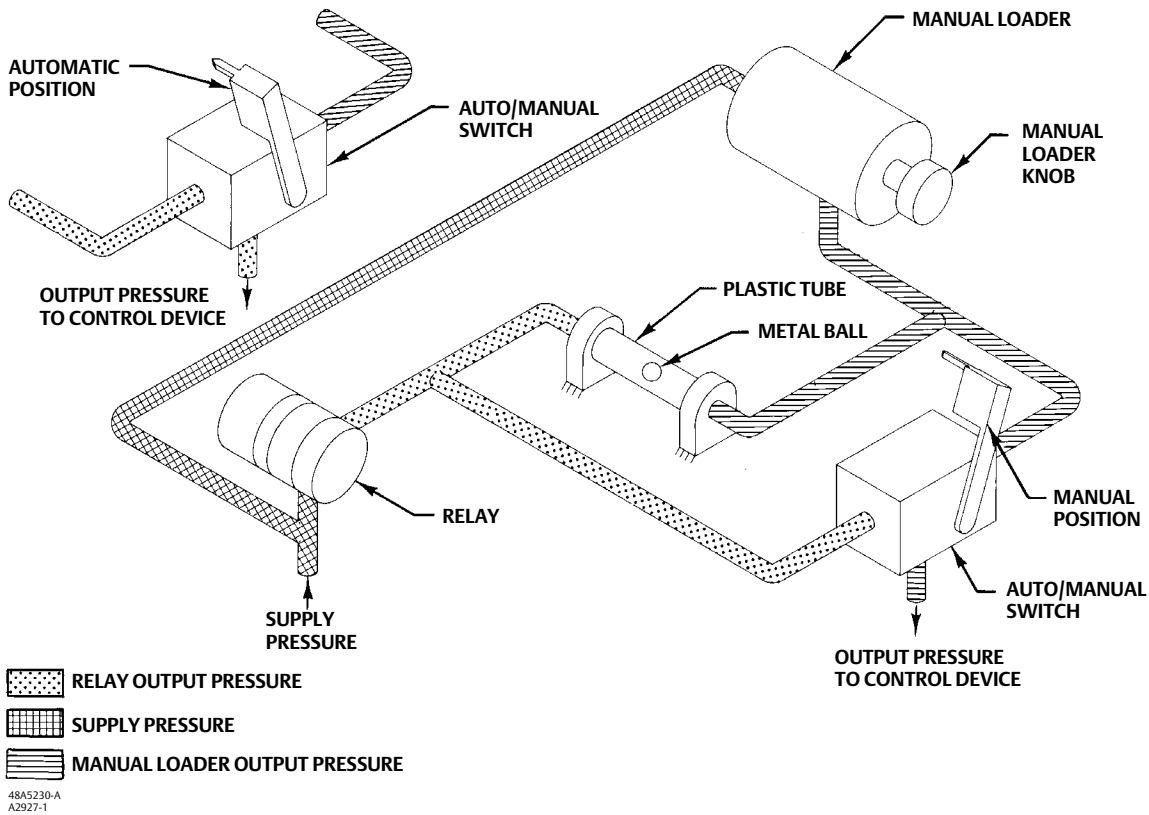

the controller is in the reverse-acting mode (see flapper detail in figure 1), an increase in process differential pressure causes a decrease in output pressure.

In addition to the 4194HA (proportional-only) version, the 4194HB controller is available for proportional-plus-reset control. In this controller, output pressure is fed back to the reset bellows as well as to the proportional bellows. Remote set point is available on all controllers. Anti-reset windup is available on all controllers with reset.

The 4194HS controller provides differential gap control. In this version, feedback pressure is piped directly to the reset bellows, reinforcing the change in flapper position rather than the counteracting it.

This construction causes the controller output to switch from full supply pressure to zero pressure or vice versa.

The schematic diagram (figure 1) emphasizes detail of construction variations between control modes. Refer to table 1 for a complete description of type number suffixes.

Auto/Manual Option

Controllers with the auto/manual option have piping on the output side of the relay as shown in figure 2. Supply pressure to the relay is also applied to the manual loader. The manual loader, functioning as a regulator, applies pressure to one side of the plastic tube and to the auto/manual switch. Output pressure from the relay registers on the other side of the plastic tube as well as in the auto/manual switch.

When the auto/manual switch is in the MAN position, the output of the manual loader, which is adjustable by the manual loader knob, is channelled through the auto/manual switch and becomes the output of the controller. When the auto/manual switch is in the AUTO position, the output of the relay is channelled through the switch to become the output of the controller.

Before the auto/manual switch is operated, the output of the relay must equal the output of the manual loader to avoid bumping the process. Adjusting the set point varies the pressure on the left-hand side of the plastic tube. Adjusting the manual loader knob varies the pressure on the right-hand side. When the pressures are equal, the metal ball is centered in the tube. Pressure imbalance will force the ball to one end of the tube where it forms a seal, blocking air flow through the tube.

Construction Features

Simple Relay Maintenance

A clean-out wire provides a fast, easy means of cleaning the relay primary orifice during service.

Pressure Protection for the Case

A rubber plug in the plastic case pops out to prevent excessive pressure buildup inside the case, thus preventing structural damage.

Easy Direct/Reverse Switching

Controller action can be switched from direct to reverse or vice versa by simply loosening the screws on the proportional band cover and moving the cover out to rotate the proportional band knob to the desired action (see figure 4).

Easy Mode Conversion

Conversion from proportional to proportional-plus-reset control requires the addition of a reset valve and two pieces of tubing. Conversion from proportional to differential gap control requires the addition of one piece of tubing.

Anti-Reset Windup

Anti-reset windup is available with proportional-plus-reset controllers. Relief valve may be installed to limit reset windup in either direction.

Remote Set Point

The capability of adjusting the set point from a remote location is available as an option on the 4194H controllers.

Auto/Manual Capability

An internal auto/manual station is available for smooth bumpless transfer from automatic to manual and manual to automatic control of the controller output. The two-position switch, showing either automatic or manual mode, is clearly visible with the controller cover closed.

External Feedback

In controller override applications, this option minimizes reset windup in the secondary controller (see figure 3). This option is available only with the two-mode (4194HB) controllers.

Figure 3. Schematic of External Feedback Option

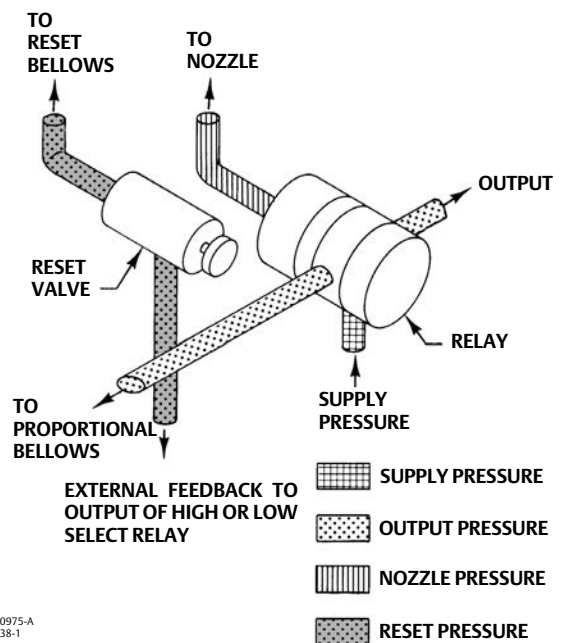

47A0975-A
A3238-1

Figure 4. Controller Construction Details

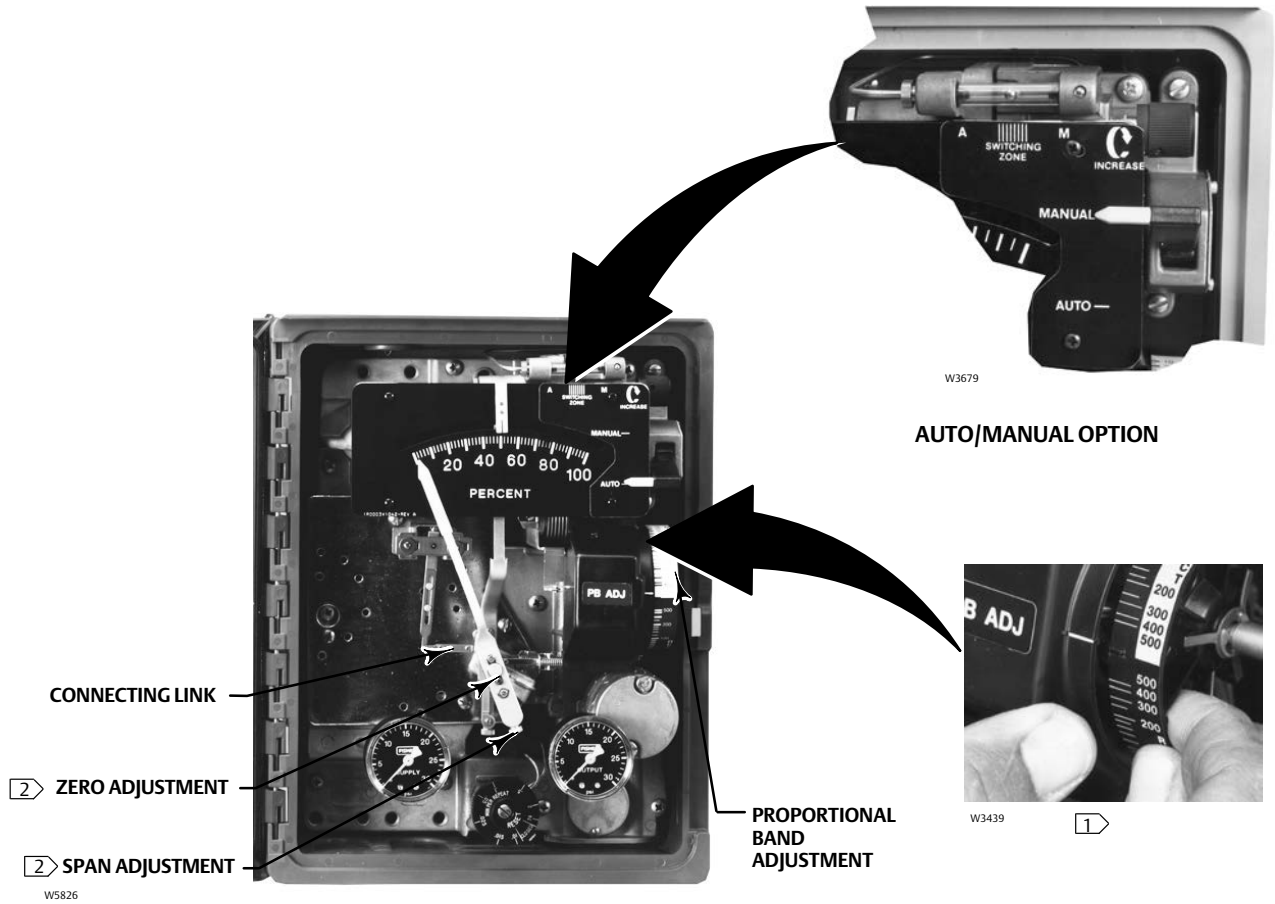

Notes:

- 1 White portion of adjustment enables direct controller action; black portion enables reverse controller action.
- 2 For the process pointer.

Figure 5. Dimensions

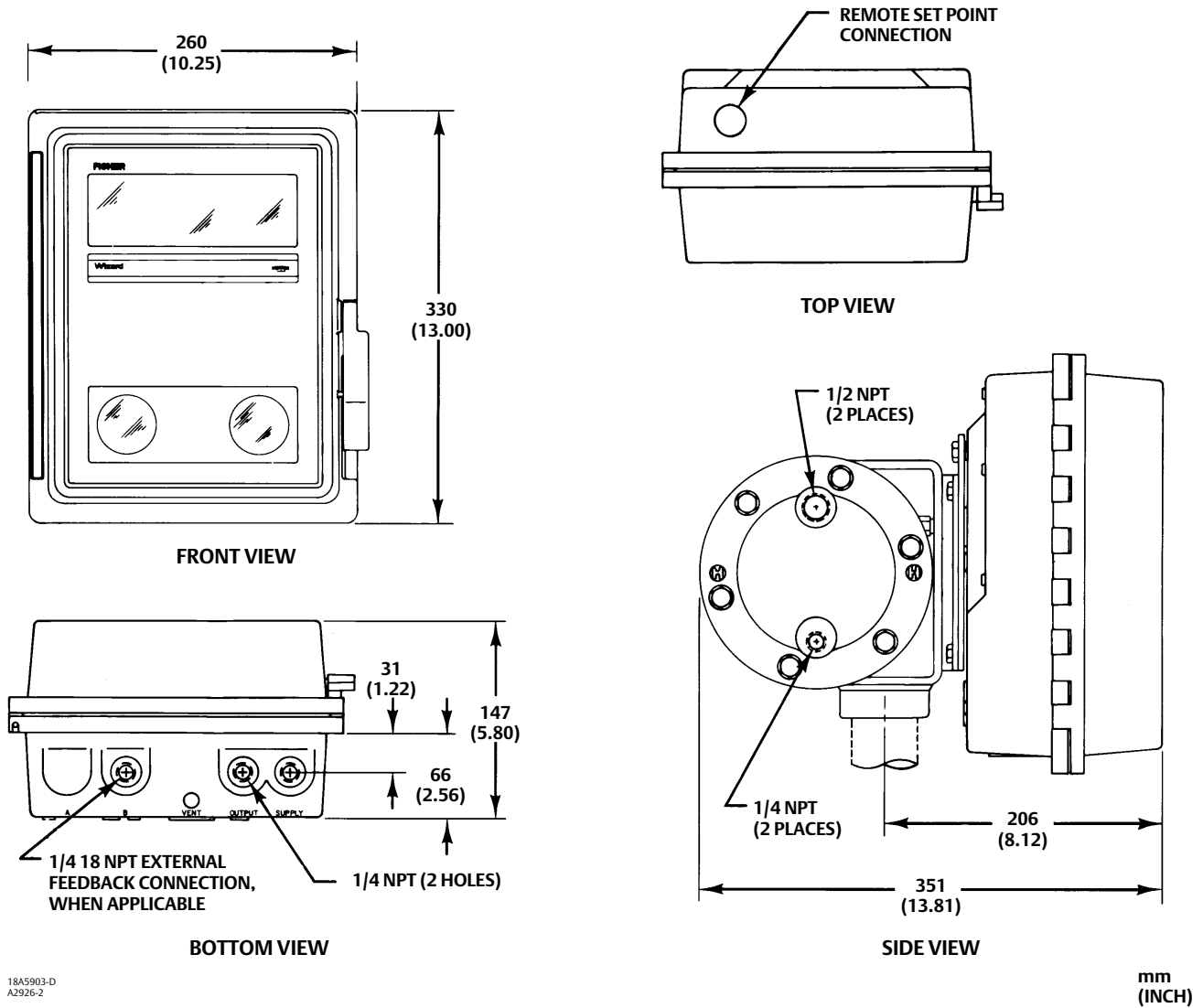

18A5903-D
A2926-2

Installation

A 4194H controller mounts on a pipestand and must be installed with the vent opening facing down. The coupling is secured to the pipestand by set screws. Figure 5 shows controller dimensions including those necessary for installation.

Ordering Information

When ordering, specify:

Application

1. Description of the service, such as throttling or on-off
2. Pressure range, composition, and temperature of process fluid
3. Ambient temperature

Construction

Refer to the specifications and the Construction Features section. Carefully review each specification and feature, indicating your choice whenever a selection is to be made. Refer to table 1 for type numbers; add R to any type number if reverse action is desired.

Neither Emerson, Emerson Automation Solutions, nor any of their affiliated entities assumes responsibility for the selection, use or maintenance of any product. Responsibility for proper selection, use, and maintenance of any product remains solely with the purchaser and end user.

Fisher is a mark owned by one of the companies in the Emerson Automation Solutions business unit of Emerson Electric Co. Emerson Automation Solutions, Emerson, and the Emerson logo are trademarks and service marks of Emerson Electric Co. All other marks are the property of their respective owners.

The contents of this publication are presented for informational purposes only, and while every effort has been made to ensure their accuracy, they are not to be construed as warranties or guarantees, express or implied, regarding the products or services described herein or their use or applicability. All sales are governed by our terms and conditions, which are available upon request. We reserve the right to modify or improve the designs or specifications of such products at any time without notice.

Emerson Automation Solutions
Marshalltown, Iowa 50158 USA
Sorocaba, 18087 Brazil
Cernay 68700 France
Dubai, United Arab Emirates
Singapore 128461 Singapore

www.Fisher.com

