

Product Bulletin

34.5:4660
D200051X012
July 2008

4660 Pressure Pilot

4660 High-Low Pressure Pilot

The 4660 pneumatic high-low pressure pilot (figure 1) activates safety shutdown systems for flowlines, production vessels, and compressors. This pilot is available with either single or dual set point capability, using patented switch points, to maintain full output pressure when the process pressure is within the set point range. If the process pressure is outside this range, the pilot switches from full output pressure to zero output pressure.

The primary switching mechanism in this pilot is a block-and-bleed relay assembly. This construction can be used in both block-and-bleed and bleed-only systems.

Unless otherwise noted, all NACE references are to NACE MR0175-2002.

Features

- **Superior Performance**—Repeatability meets the U.S. Minerals Management Service test tolerances referenced in Outer Continental Shelf (OCS) Order No. 5 and defined in the American Petroleum Institute (API) RP14C standard.
- **Easy Maintenance**—Simple modular construction plus a line of prepackaged parts kits makes pilot maintenance fast and easy.
- **Reliable Operation**—The pilot uses a field-proven Bourdon tube process pressure sensing element that reduces maintenance by eliminating the need for wetted dynamic O-rings.



FRONT VIEW



LEFT SIDE WITH CASE COVER OFF

Figure 1. 4660 High-Low Pressure Pilot with Block and Bleed Relay

- **Environmental Packaging**—Construction materials have been selected to protect the pilot from corrosive environments such as the salt spray atmosphere of offshore platforms.



Table 1. Additional Specifications, Bar

| BOURDON TUBE RATING ⁽¹⁾ | SET RANGE ⁽¹⁾ | SET POINT ΔP_{MIN} (MINIMUM ALLOWABLE DIFFERENCE BETWEEN HIGH AND LOW SETTINGS) | | TRIP-TO-RESET ZONE |
|------------------------------------|--------------------------|---|-----------------------------|--------------------|
| | | Single High-Low Unit | High-Only/ Low-Only Pair | |
| 7 | 0.3 to 6.6 | 0.7 | 0.2 | ≤0.1 |
| 17 | 0.6 to 16.6 | 1.7 | 0.5 | 0.3 |
| 35 | 1.1 to 33.4 | 3.5 | 1.0 | 0.5 |
| 70 | 2.1 to 67.9 | 6.9 | 2.1 | 1.0 |
| 100 | 3.2 to 100.2 | 10.3 | 3.1 | 1.6 |
| 170 | 5.2 to 167.2 | 17.2 | 5.2 | 2.6 |
| 350 | 10.4 to 334.4 | 51.7 | 10.3 | 5.2 |
| 500 | 15.6 to 501.5 | 70.7 | 15.5 | 7.8 |
| 700 ⁽²⁾ | 20.7 to 668.8 | 103.4 | 20.7 | 10.3 |

1. Rating indicated on Bourdon tube and set range on front panel are in kPa (1 bar = 100 kPa).
2. Available in N05500 nickel alloy only, for NACE.

Table 2. Additional Specifications, Psig

| BOURDON TUBE RATING | SET RANGE | SET POINT ΔP_{MIN} (MINIMUM ALLOWABLE DIFFERENCE BETWEEN HIGH AND LOW SETTINGS) | | TRIP-TO-RESET ZONE |
|-----------------------|-------------|---|-----------------------------|--------------------|
| | | Single High-Low Unit | High-Only/ Low-Only Pair | |
| 100 | 3 to 97 | 10 | 3.0 | ≤1.5 |
| 250 | 8 to 242 | 25 | 7.5 | 3.8 |
| 500 | 5 to 485 | 50 | 15 | 7.5 |
| 1000 | 30 to 970 | 100 | 30 | 15 |
| 1500 | 45 to 1455 | 150 | 45 | 23 |
| 2500 | 75 to 2425 | 250 | 75 | 38 |
| 5000 | 150 to 4850 | 750 | 150 | 75 |
| 7500 | 225 to 7275 | 1025 | 225 | 113 |
| 10,000 ⁽¹⁾ | 300 to 9700 | 1500 | 300 | 150 |

1. Available in N05500 nickel alloy only, for NACE

- **Vibration Resistance**—The rugged Bourdon tube sensing element and shock-absorbing switch points dampen the effects of vibration while maintaining performance.

- **Set Point Accuracy**—Standard high-resolution set point adjustments are easy to set, non-interactive, and can be locked in place to maintain the desired set point. The optional set point indication assemblies on the front panel are easy to read and let you simply dial in the desired set point.

- **Cost-Effective Design**—One pilot provides either a high-low function or a single switch point, whichever the application requires.

- **Installation Versatility**—Panel, rack, pipestand, or actuator mounting is available to meet field requirements.

- **Operational Indications**—A supply pressure test function is provided. The optional output indicator lets you check at a glance whether the pilot output pressure is at full output or zero output pressure.

- **NACE Conformance**—An N05500 nickel alloy Bourdon tube is available for those applications where the pilot must meet the requirements of NACE Standard MR0175-2002.

Specifications

Available Configurations

- High-low, ■ low-only, or ■ high-only set point capability

Input Signal

Type: Process pressure sensed with a Bourdon tube

Bourdon Tube Ratings: See table 1 or 2

Overpressure Protection: Maximum allowable emergency process pressures and maximum allowable process pressures to ensure set point readjustability are shown in table 3

Output Signal

- Zero pressure or ■ full supply pressure (automatically resets)

Supply Pressure⁽¹⁾

Normal Operating Pressure: 1.4 to 4.4 bar (20 to 65 psig)

Medium: Air or natural gas⁽²⁾

Quality: Should be dry with solid particles removed

Steady-State Air Consumption⁽³⁾

Output Signal at 0 psig: ≤ 0.134 normal m^3/hr (≤ 5 Scfh)

Output Signal at Full Supply Pressure: ≤ 0.00134 normal m^3/hr (≤ 0.05 Scfh)

Set Point Adjustments

Continuously adjustable between 3 and 97% of Bourdon tube rating; see table 1 or 2 for ranges

Performance in Percentage of Bourdon Tube Rating

Repeatability: $\leq 0.25\%$

Set Point ΔP_{min}
(See table 1 or 2)

Single High-Low Unit: 10% for up to 170 bar (2500 psig) Bourdon tubes; 15% for 350, 500, and 700 (NACE) bar (5000, 7500, and 10,000 (NACE) psig) Bourdon tubes

Low-Only and High-Only Pair: 3%

Trip-to-Reset Zone: $\leq 1.5\%$ (see table 1 or 2)

Exhaust Capacity

$C_g \geq 15$

Construction Materials

Case and Cover: Polyester

Front Cover: Tinted polycarbonate with scratch-resistant coating

Base: Hard-anodized nickel-sealed aluminum alloy

Bourdon Tube: ■ 316 stainless steel, or ■ N05500 nickel alloy

Relay Body, Relay Flange, Nozzle/Flapper Assembly Orifice Block, and Switch Point.

Housings: Glass-filled polyphenylene sulfide

Relay Diaphragm: ■ Nitrile/Polyester or

■ Fluorosilicone/Polyester (low temperature version), or ■ Fluorocarbon/Polyester

Relay Disks: ■ Nitrile, ■ Fluorosilicone (low temperature version), or

■ Fluorocarbon/Polyester

Process Pressure Block, Tubing, Front Plate, Flapper, Linkages, and Other Major Metal

Parts: Stainless steel

Gaskets: Chloroprene and nitrile

O-Rings

Relay: ■ Nitrile or ■ Fluorocarbon

Switchpoint Assembly: Nitrile impregnated with molybdenum disulphide

Base/Case: Nitrile

Operating Conditions⁽¹⁾

| Condition | Normal Operating Limits | Nominal Reference |
|---------------------|--|-------------------|
| Ambient Temperature | Nitrile Elastomers: -40 to 60°C (-40 to 140°F) | 21°C (70°F) |
| | Fluorocarbon Elastomers: -7 to 71°C (-20 to 160°F) | |
| | Fluorosilicone Elastomers: (Low Temperature Version) -75°F (-59°C) | |
| Process Temperature | -29 to 93°C (-20 to 200°F) | 21°C (70°F) |

(continued)

Specifications (continued)

Operating Influences on Switch Point Sensitivity

Supply Pressure: ≤0.05% of Bourdon tube rating for a 10% change in supply pressure

Ambient Temperature: ■ ≤1.5% (standard construction) or ■ ≤2.5% (low temperature version) of Bourdon tube rating throughout normal operating limits with nominal reference

Time: ≤1% of Bourdon tube rating over 30 days at ambient temperature nominal reference

Process Pressure: Range shift or set point drift can occur if process pressure exceeds the Bourdon tube rating

Pressure Connections

1/4 NPT internal

Mounting

■ Panel, ■ rack, ■ pipestand, or ■ actuator

Hazardous Area Classification

Complies with the requirements of ATEX Group II Category 2 Gas and Dust

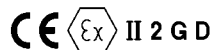

Approximate Weight

2.3 kg (5 pounds)

Options

■ Visual output indication, ■ fluorocarbon elastomers in relay, ■ low-temperature version to -59°C (-75°F) ■ 316 stainless steel panel mounting flange, ■ set point indication, and ■ tamper-resistant front cover

NOTE: Specialized instrument terms are defined in ANSI/ISA Standard 51.1 – Process Instrument Terminology.

1. The pressure/temperature limits in this document and any applicable standard or code limitation for valve should not be exceeded.

2. Natural gas to contain no more than 20 ppm of H₂S.

3. Normal m³/h--Normal cubic meters per hour at 0°C and 1.01325 bar, absolute. Scfh--Standard cubic feet per hour at 60°F and 14.7 psia.

Table 3. Maximum Allowable Process Pressure⁽¹⁾

| BOURDON TUBE RATING | | MAXIMUM ALLOWABLE EMERGENCY PROCESS PRESSURE | | | |
|---|--------|--|------|--|--------|
| Bar ⁽²⁾ | Psig | Stainless Steel Bourdon Tubes | | N05500 Nickel Alloy Bourdon Tubes (NACE) | |
| | | Bar ⁽²⁾ | Psig | Bar ⁽²⁾ | Psig |
| 6.9 | 100 | 13.8 | 200 | 13.8 | 200 |
| 17.2 | 250 | 34.2 | 500 | 34.2 | 500 |
| 34.5 | 500 | 69.0 | 1000 | 69.0 | 1000 |
| 69.0 | 1000 | 138.0 | 2000 | 138.0 | 2000 |
| 103.4 | 1500 | 206.8 | 3000 | 206.8 | 3000 |
| 172.4 | 2500 | 344.8 | 5000 | 258.6 | 3750 |
| 344.8 | 5000 | 517.2 | 7500 | 430.9 | 6250 |
| 517.2 | 7500 | 646.3 | 9375 | 568.8 | 8250 |
| 689.5 | 10,000 | N/A | N/A | 758.5 | 11,000 |
| Maximum Allowable Process Pressure to Ensure Set Point Readjustability ⁽³⁾ | | | | | |
| 6.9 | 100 | 13.8 | 200 | 13.8 | 200 |
| 17.2 | 250 | 34.8 | 500 | 22.3 | 325 |
| 34.5 | 500 | 51.7 | 750 | 53.4 | 775 |
| 69.0 | 1000 | 103.5 | 1500 | 89.7 | 1300 |
| 103.4 | 1500 | 155.1 | 2250 | 124.0 | 1800 |
| 172.4 | 2500 | 172.4 | 2500 | 227.5 | 3300 |
| 344.8 | 5000 | 517.2 | 7500 | 344.8 | 5000 |
| 517.2 | 7500 | 646.3 | 9375 | 517.2 | 7500 |
| 689.5 | 10,000 | N/A | N/A | 689.5 | 10,000 |

1. Normal operating process pressures should not exceed the Bourdon tube rating.
 2. Ratings indicated on Bourdon tube are in psig and kPa (1 bar = 100 kPa).
 3. Values listed for the N05500 nickel alloy Bourdon tubes are for a 2% deviation from set point due to overpressure.

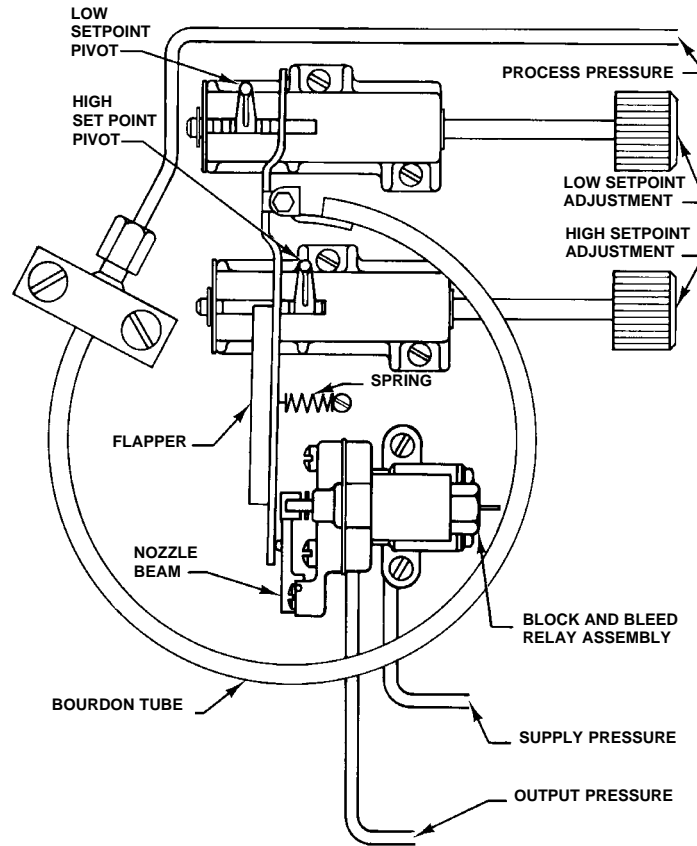

38A3903-A
A2898-2 / IL

Figure 2. Principle of Operation Schematic

Principle of Operation

Refer to figure 2.

Process pressure is connected to the Bourdon tube sensing element. While the process pressure remains in the adjusted set ranges (between the low set point and the high set point), the flapper does not contact either set point pivot. This keeps the nozzle capped and maintains full output pressure.

As the process pressure decreases below the low set point value, the radius of arc of the Bourdon tube contracts. This causes the flapper to contact the low set point pivot and uncap the nozzle, which blocks supply pressure and vents (bleeds) output pressure. As the process pressure increases above the high set point value, the radius of arc of the Bourdon tube extends. This causes the flapper to contact the high set point pivot, also uncapping the nozzle and providing block-and-bleed action. When the process pressure returns to the set range, the nozzle is again

capped, switching the relay back to maintain full output pressure.

Performance

The performance characteristics shown in figure 3 and table 4 illustrate several important functional parameters.

S_L represents the low set point and S_H represents the high set point. The set range capability is 3 to 97 percent of the Bourdon tube rating. However, with a single high-low unit or a high-only/low-only pair, there is a limit on how close to each other the set points can be adjusted. This limit is defined as set point ΔP_{MIN} and is shown as S_L' and S_H' .

Trip-to-reset is the combined effect of pilot deadband and hysteresis. After the pilot has tripped, it automatically resets when the process pressure returns to the set range. However, full output pressure is not instantaneous. The difference between the set point and reset to full output pressure is the trip-to-reset zone. This parameter is

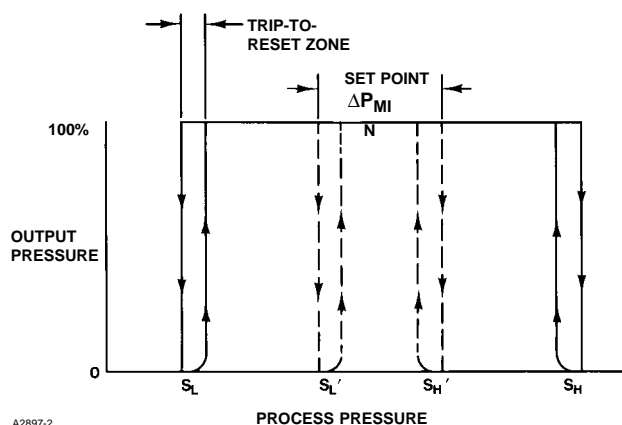

A2897-2

Figure 3. Performance Characteristics (also see table 4)

also a function of the Bourdon tube rating as shown in figure 3 and table 4.

Repeatability is the switch point deviation around the set point as a percentage of the Bourdon tube rating.

Applications

Figure 4 shows some of the many ways in which the 4660 high-low pressure pilot may be connected to accommodate requirements for single and dual outputs as well as single and dual process pressure lines. Examples A and D in figure 4 show how a pair of high-only and low-only pilots are connected to obtain closer set points as specified by the set point ΔP_{MIN} values in tables 1 and 2. Example B or C shows connections for a two-segment flow line configuration that adheres to API Specification RP14C. Example E shows a typical connection to an electrical pressure switch.

Installation

Normal installation is with the pilot mounted vertically and the connections for process pressure, supply pressure, and output pressure facing down. The supply medium should be regulated dry air or natural gas with solid particles removed.

Figures 5 and 6 illustrate the mounting dimensions and the location of the pressure connections.

Table 4. Performance Characteristics

| CONSTRUCTION | PERCENT OF BOURDON TUBE RATING | | |
|--------------------------|--------------------------------|--------------------|---------------|
| | SET POINT ΔP_{MIN} | TRIP-TO-RESET ZONE | REPEATABILITY |
| Single High-Low Unit | 10 ⁽¹⁾ | 1.5 | 0.25 |
| High-Only/ Low-Only Pair | 3 | | |

1. 5000 and 7500 Psig Bourdon tubes are 15 percent of Bourdon tube rating.

Ordering Information

When ordering, specify:

Application

- Bourdon tube rating and material
- Composition, pressure, and temperature of the process fluid
- Ambient temperature range
- Description of application

Construction

Refer to the Specifications table. Review the information under each specification and in the referenced tables; specify the desired selection whenever there is a choice to be made.

Note

Neither Emerson, Emerson Process Management, nor any of their affiliated entities assumes responsibility for the selection, use, or maintenance of any product. Responsibility for the selection, use, and maintenance of any product remains with the purchaser and end-user.

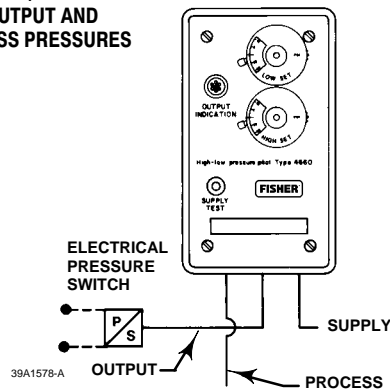
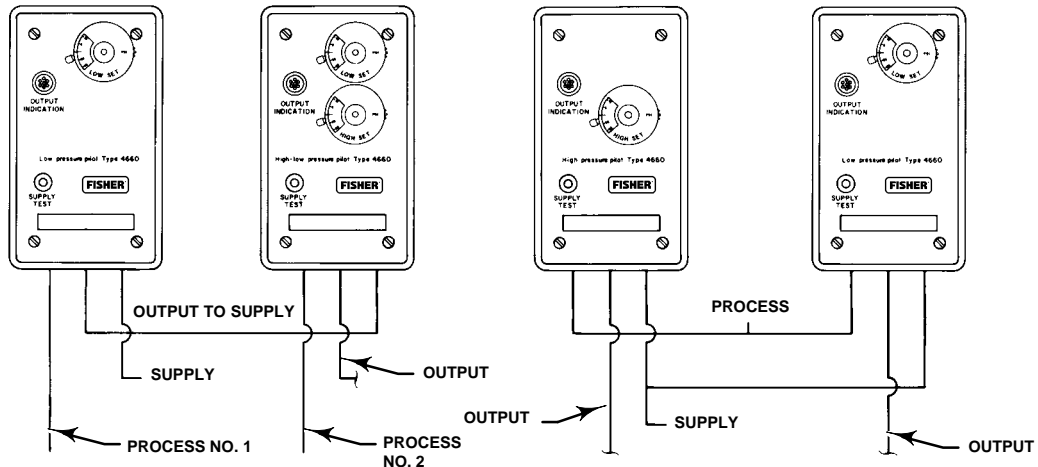
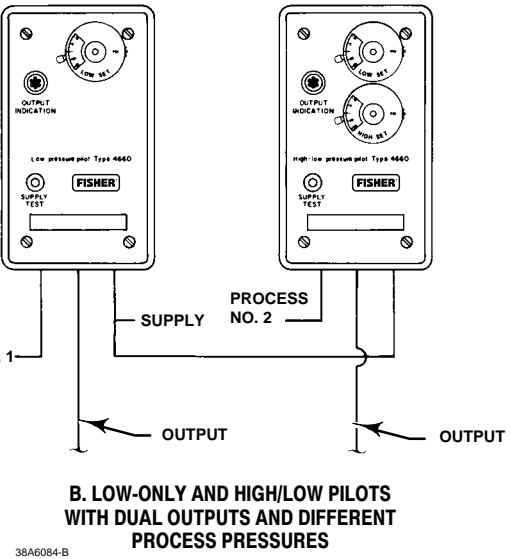
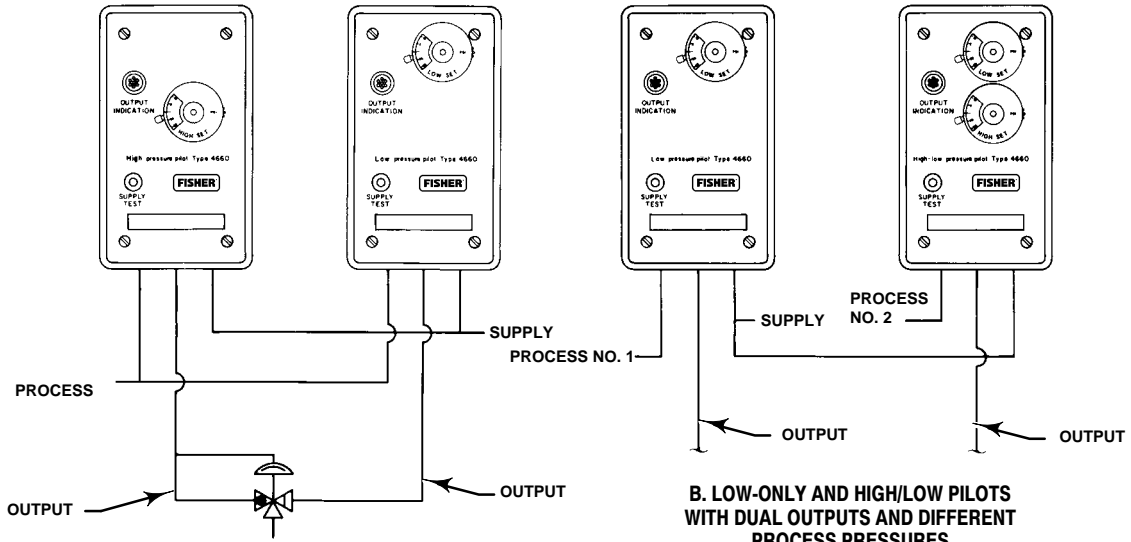
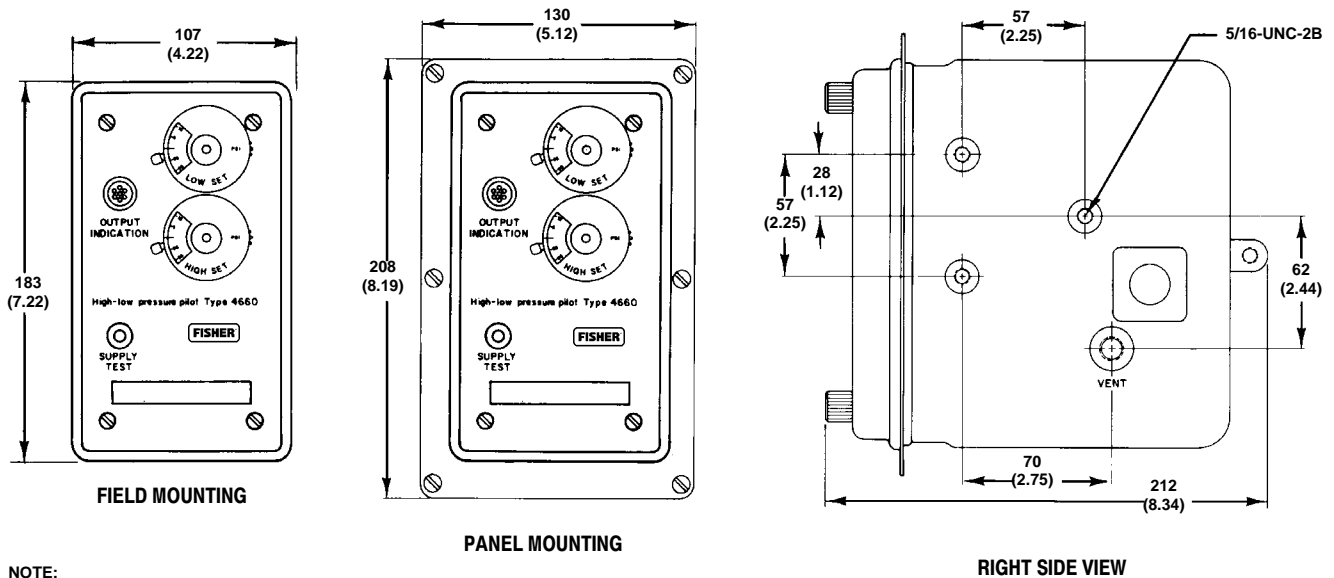

Figure 4. Typical Connection Schematics

4660 Pressure Pilot



NOTE:
 ALL CONNECTIONS ARE 1/4 NPT.

39A1578-A
 18A3804-G
 B1589-3 / IL

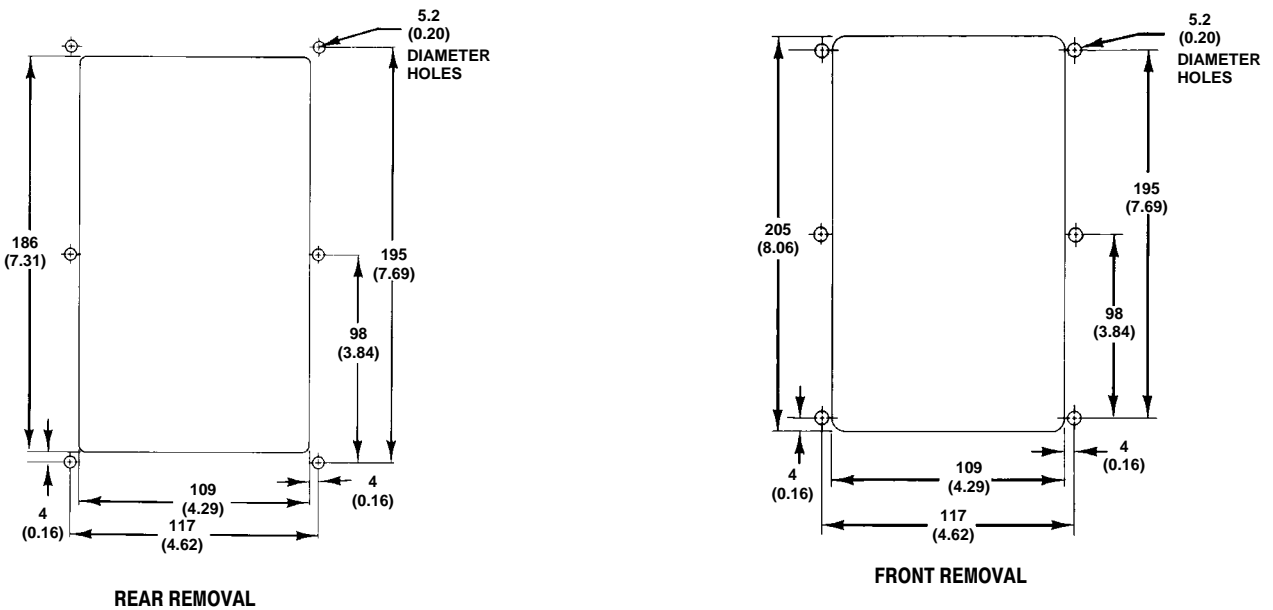

18A3804-F
 A3299-1 / IL

mm
 (INCH)

Figure 5. Panel Mounting Dimensions

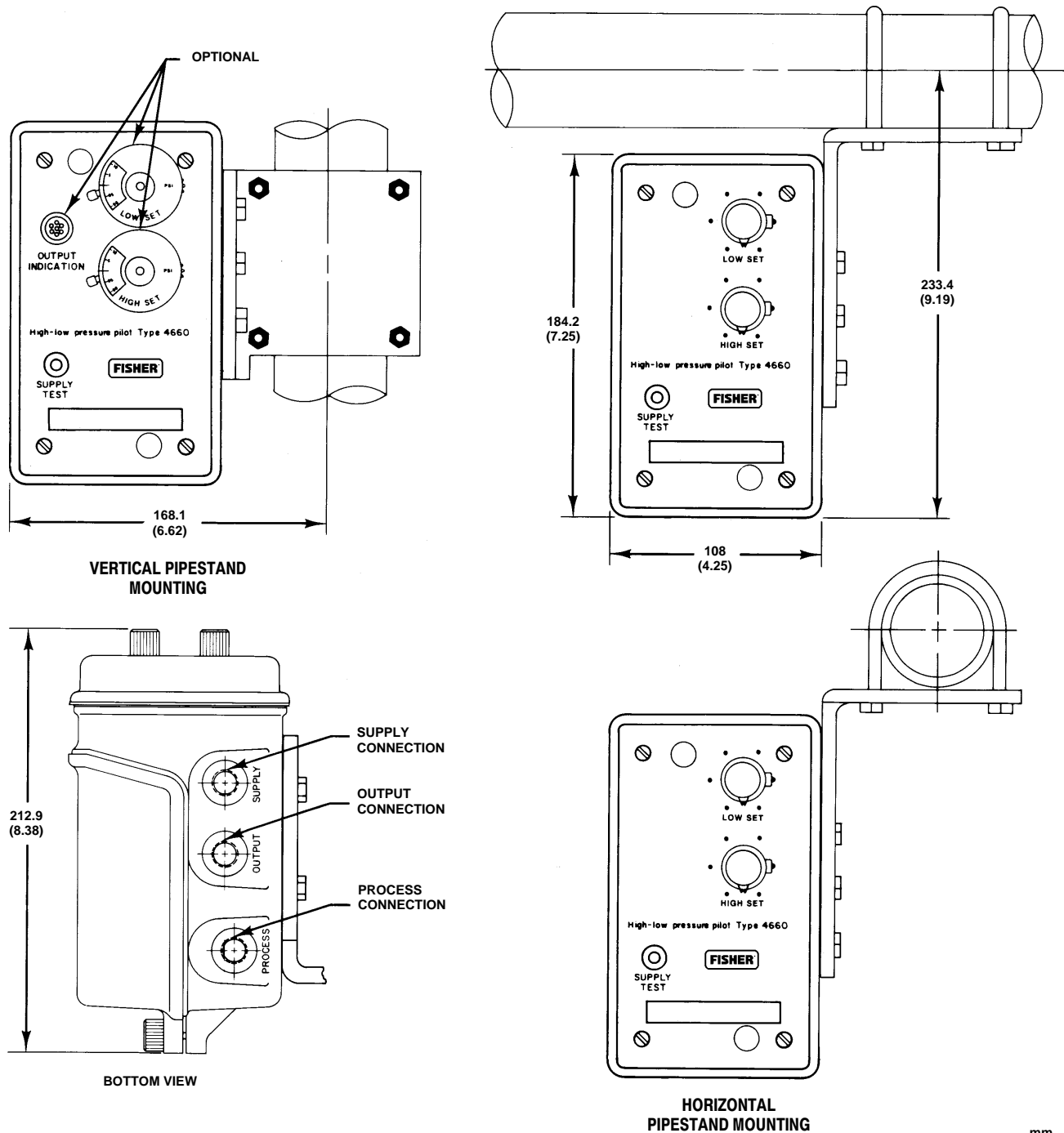

mm
(INCH)

10B2287-B
B1965 / IL

Figure 6. Pipestand Mounting Dimensions

Fisher is a mark owned by Fisher Controls International LLC, a member of the Emerson Process Management business division of Emerson Electric Co. Emerson Process Management, Emerson, and the Emerson logo are trademarks and service marks of Emerson Electric Co. All other marks are the property of their respective owners.

The contents of this publication are presented for informational purposes only, and while every effort has been made to ensure their accuracy, they are not to be construed as warranties or guarantees, express or implied, regarding the products or services described herein or their use or applicability. We reserve the right to modify or improve the designs or specifications of such products at any time without notice.

Neither Emerson, Emerson Process Management, nor any of their affiliated entities assumes responsibility for the selection, use and maintenance of any product. Responsibility for the selection, use and maintenance of any product remains with the purchaser and end-user.

Emerson Process Management

Marshalltown, Iowa 50158 USA

Sorocaba, 18087 Brazil

Chatham, Kent ME4 4QZ UK

Dubai, United Arab Emirates

Singapore 128461 Singapore

www.Fisher.com

