

# 4156K and 4166K Temperature Controllers

The 4156K and 4166K Series Wizard® II temperature controllers (figure 1) provide rugged and economical solutions to temperature control in many applications, particularly in the chemical and oil production industries. These pneumatic instruments are available for proportional-only, proportional-plus-reset, and differential gap control. They measure process temperature with a gas-filled temperature bulb immersed in the process fluid and compare this temperature to an operator-adjusted set point. The controller then delivers a pneumatic signal to a control element that maintains the process temperature at or near the set point.

## Features

- **Sensitive Response**—A nozzle-flapper arrangement and a three-to-one relay allow small process temperature changes to induce large output pressure changes.
- **Mounting Versatility**—Install the controller on a panel, wall, or pipestand, as well as on an actuator (as shown in figure 1). The temperature element is

adjustable for desired penetration into the process vessel.

- **Easy Adjustments**—Temperature set point, proportional band, and reset are adjustable with large, easy-to-read dial-knob controls.
- **Continuous Indication of Process Temperature**—A temperature gauge, calibrated for the specific measurement range, monitors the process temperature continuously.
- **Easy Maintenance**—Simple design of the controller allows fast, easy maintenance and minimum spare parts inventory.

## Note

**Neither Emerson, Emerson Process Management, nor any of their affiliated entities assumes responsibility for the selection, use, and maintenance of any product. Responsibility for the selection, use, and maintenance of any product remains with the purchaser and end-user.**

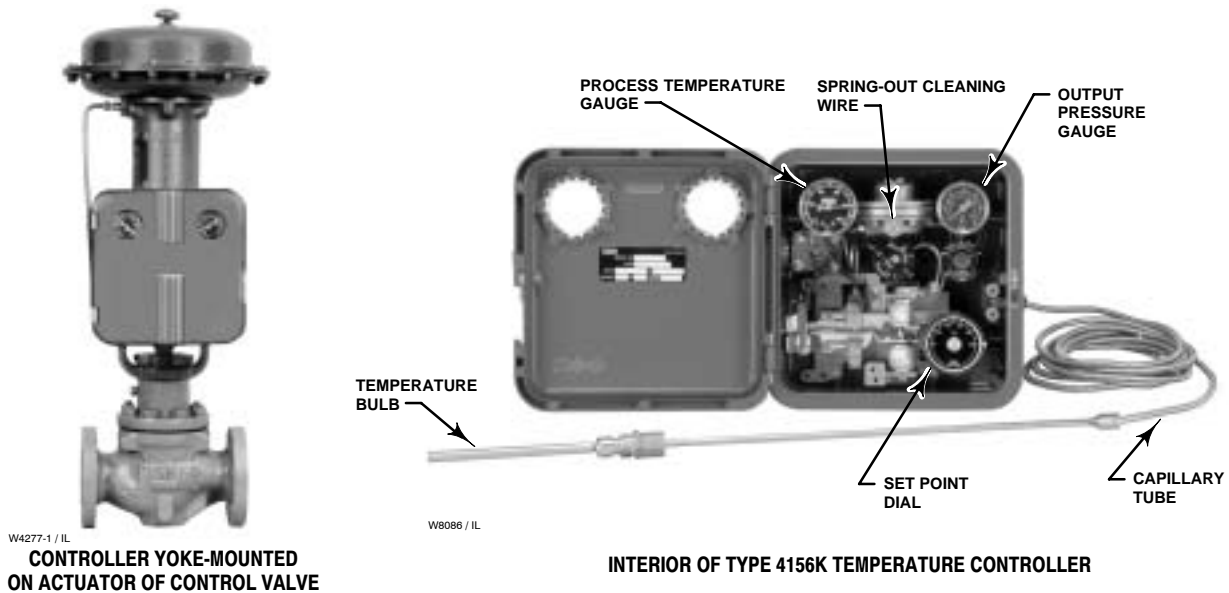

Figure 1. Type 4156K Controller



## Specifications

### Available Configurations

See table 1

### Input Signal<sup>(1)</sup>

**Type:** Temperature between 0°C and 500°C or 0°F and 1000°F; see table 2 for available ranges

**Minimum Span<sup>(1)</sup>:** 100°C or 100°F

**Maximum Span<sup>(1)</sup>:** 500°C or 1000°F

### Output Signal<sup>(1)</sup>

**Proportional-Only or Proportional-Plus-Reset Controllers:**

■ 0.2 to 1.0 bar (3 to 15 psig) or

■ 0.4 to 2.0 bar (6 to 30 psig) pneumatic pressure signal

**Differential Gap Controllers:**

■ 0 and 1.4 bar (0 and 20 psig) or

■ 0 and 2.4 bar (0 and 35 psig) pneumatic pressure signal

**Action:** Control action is field reversible between ■ direct (increasing sensed temperature produces increasing output signal) and ■ reverse (increasing sensed temperature produces decreasing output signal). The suffix R is added to the type number of a construction specified for reverse action.

### Supply Pressure<sup>(3)</sup>

See table 3

### Steady-State Air Consumption<sup>(1)</sup>

See figure 2

### Supply and Output Connections

1/4-inch NPT female

### Maximum Allowable Pressure in Closed Vessel (For Temperature Bulb)

**3/8-inch (10 mm) Temperature Bulb:** 69 bar (1000 psig) at 38°C (100°F)

**9/16-inch (14 mm) Temperature Bulb:** 34.5 bar (500 psig) at 38°C (100°F)

### Proportional Band<sup>(1)</sup> Adjustment

**For Proportional-Only or Proportional-Plus-Reset Controllers**

Full output pressure change adjustable over percent of sensing element temperature range as follows:

**Proportional-Only Controllers:**

■ 3% to 100% [0.2 to 1.0 bar (3 to 15 psig)] or

■ 6% to 100% [0.4 to 2.0 bar (6 to 30 psig)]

**Proportional-Plus-Reset Controllers:**

■ 6% to 200% [0.2 to 1.0 bar (3 to 15 psig)] or

■ 12% to 200% [0.4 to 2.0 bar (6 to 30 psig)]

### Differential Gap Adjustment

**For Differential Gap Controllers:** Full output pressure change adjustable from 15% to 100% of sensing element temperature range

### Reset<sup>(1)</sup> Adjustment

**For Proportional-Plus-Reset Controllers:**

Adjustable from 0.01 minutes to more than 74 minutes per repeat (from 100 repeats per minute to less than 0.0135 repeats per minute)

### Performance

**Repeatability<sup>(1)</sup>:** 0.5% of sensing element temperature range

**Dead Band<sup>(1)</sup> (Except Differential Gap Controllers<sup>(2)</sup>):** 0.1% of output span

**Time Constant of Temperature Bulb:** 9 to 18 seconds (bare bulb in agitated liquid)

### Ambient Operating Temperature Limits<sup>(3)</sup>

-40 to 71°C (-40 to 160°F)

### Typical Ambient Temperature Operating Influence

**Proportional Control Only:** Output pressure changes ±3.0% of sensing element range for each 28°C (50°F) change in ambient temperature for a controller set at 100% proportional band

**Reset Control Only:** Output pressure changes ±2.0% of sensing element range for each 28°C (50°F) change in ambient temperature for a controller set at 100% proportional band

### Process Temperature Indication

Standard on all controllers and calibrated for the temperature range ordered

### Hazardous Area Classification

Complies with the requirements of ATEX Group II Category 2 Gas and Dust

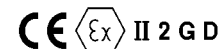
 II 2 G D

### Capillary Lengths

**Standard:** 4.6 m (15 foot)

**Optional:** Consult your Emerson Process Management™ sales office for other lengths

### Approximate Weight

8.2 kg (18 pounds)

-continued-

**Product Bulletin**

34.6:4156K  
February 2007

**4156K and 4166K Controllers**

**Specifications (continued)**

<p><b>Construction Materials</b> See table 4</p> <p><b>Output Pressure Gauge Indications</b> See table 5</p>	<p><b>Options</b> ■ Stainless steel bellows and ■ stainless steel relay</p>
--	---

1. These terms are defined in ISA Standard S51.1.  
 2. An adjustable differential gap (differential gap controllers) is equivalent to an adjustable deadband.  
 3. The pressure/temperature limits in this document and any applicable standard or code limitation should not be exceeded.

*Table 1. Available Configurations*

Type Number <sup>(1)</sup>	Proportional-Only	Proportional-Plus-Reset	Differential Gap	Anti-Reset Windup
4156K	X			
4156KS			X	
4166K		X		
4166KF		X		X

1. The suffix R is added to the type number of a construction specified for reverse action.

*Table 2. Temperature Ranges of Temperature Element Assemblies<sup>(1)</sup>*

TEMPERATURE SPAN, °C	TEMPERATURE RANGE, °C	OVERRANGE LIMITS, °C <sup>(2)</sup>
100	0 to 100	200
150	0 to 150	200
200	0 to 200	330
250	0 to 250	500
300	0 to 300	500
400	0 to 400	500
500	0 to 500	600
TEMPERATURE SPAN, °F	TEMPERATURE RANGE, °F	OVERRANGE LIMITS, °F <sup>(2)</sup>
100	0 to 100	200
	50 to 150	225
	100 to 200	250
150	50 to 200	370
200	0 to 200	470
	50 to 250	435
300	0 to 300	400
400	0 to 400	780
600	0 to 600	870
800	0 to 800	1000
1000	0 to 1000	1200

1. Class IIIB per SAMA Standard RC6-10.  
 2. With 4.6 m (15 foot) capillary tube. If these limits are exceeded, a permanent zero shift may result.

*Table 3. Supply Pressure Requirements*

OUTPUT SIGNAL RANGE		NORMAL OPERATING SUPPLY PRESSURE <sup>(1)</sup>		MAXIMUM ALLOWABLE SUPPLY PRESSURE TO PREVENT INTERNAL PART DAMAGE <sup>(2)</sup>	
Bar	Psig	Bar	Psig	Bar	Psig
0.2 to 1.0 (0 and 1.4 differential gap)	3 to 15 (0 and 20 differential gap)	1.4	20	2.8	40
0.4 to 2.0 (0 and 2.4 differential gap)	6 to 30 (0 and 35 differential gap)	2.4	35	2.8	40

1. If this pressure is exceeded, control may be impaired.  
 2. If this pressure is exceeded, damage to the controller may result.

# 4156K and 4166K Controllers

Table 4. Construction Materials

Part	Material
Thermal element assembly <sup>(1)</sup>	Stainless steel
Interior Tubing	Stainless steel
Exterior Tubing	Copper (with or without PVC plastic lining), stainless steel, or synthetic rubber
Exterior fittings	Brass or stainless steel
Nozzle and reversing block	Stainless steel/zinc
Relay springs and spring plate	Stainless steel
Relay diaphragms	Nitrile
Other metal relay parts, proportional bellows, and/or exhaust/reset bellows	Aluminum/brass or aluminum/stainless steel
Reset valve assembly and differential relief valve (Types 4166K and 4166KF controllers only)	Aluminum/brass/zinc/plated steel
O-rings	Nitrile
Gaskets	Chloroprene
Cover	Marine-grade aluminum (Alloy 13) with glass gauge windows
Case and set point dial	Aluminum
Proportional valve assembly	Brass/plated steel or stainless steel
Flapper	K93602 nickel alloy
Control link	N04400 nickel alloy and/or stainless steel
Flexure and temperature setting adjustment assemblies	Aluminum/steel/stainless steel/plastic
Calibration adjuster	Zinc
Bushing <sup>(2)</sup>	Brass <sup>(3)</sup> or stainless steel
Thermowell <sup>(2)</sup>	Brass <sup>(3)</sup> carbon steel, N04400 nickel alloy, or stainless steel

1. Contacts the process fluid unless used in a thermowell.  
2. Contacts the process fluid.  
3. For use with 10 mm (3/8 inch) diameter temperature bulb only.

Table 5. Output Pressure Gauges

GAUGE SCALE	GAUGE RANGE	
	For .2 to 1.0 Bar (3 to 15 psig) or 0 and 1.4 Bar (0 and 20 psig) Output	For 0.4 to 2.0 Bar (6 to 30 Psig) or 0 and 2.4 Bar (0 and 35 psig) Output
Triple	0 to 30 psig/0 to 0.2 MPa/0 to 2 Bar	0 to 60 psig/0 to 0.4 MPa/0 to 4 Bar
Dual	0 to 30 psig/0 to 2 kg/cm <sup>2</sup>	0 to 60 psig/0 to 4 kg/cm <sup>2</sup>

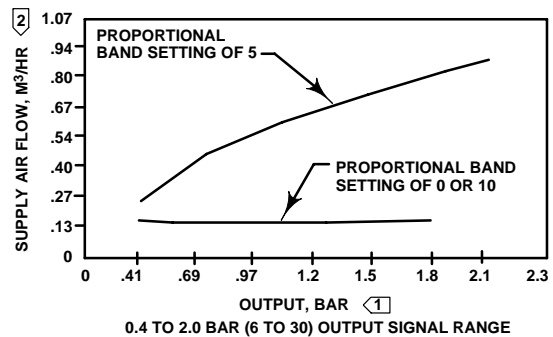
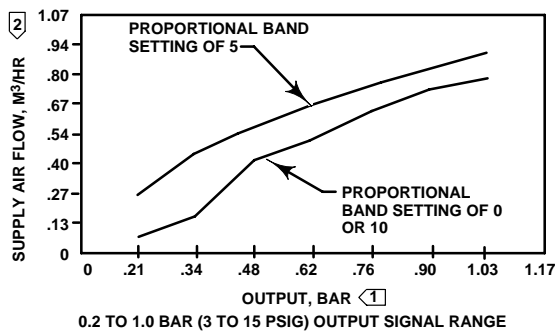

NOTES

- [1] TO CONVERT BAR TO PSIG DIVIDE BY 0.06895.  
[2] M<sup>3</sup>/HR-NORMAL CUBIC METERS PER HOUR (0°C AND 1.01325 BAR, ABSOLUTE) TO CONVERT TO SCFH-STANDARD CUBIC FEET PER HOUR (60°F AND 14.7 PSIG) DIVIDE BY 0.0268

E0473 / IL

Figure 2. Steady-State Air Consumption

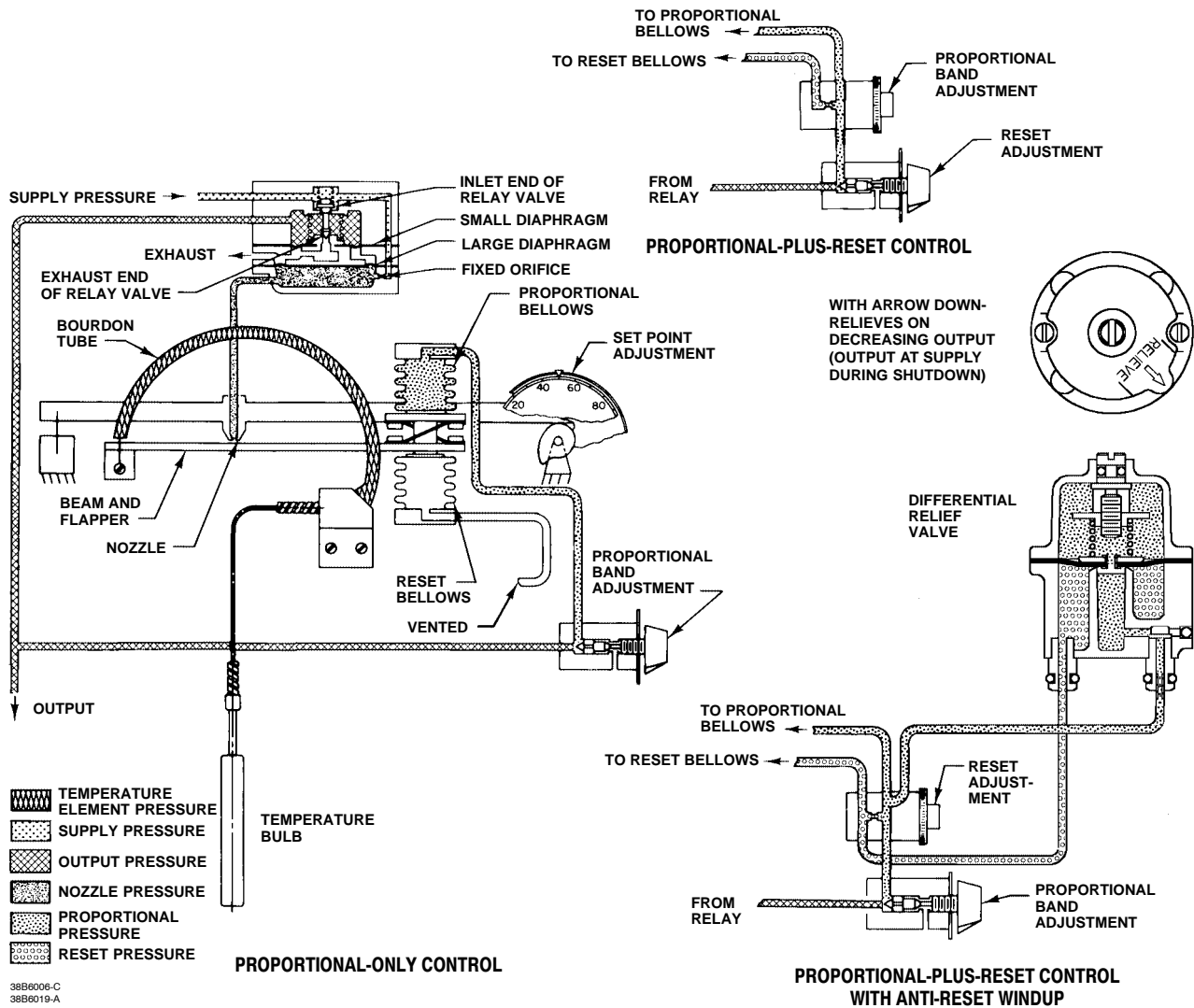

Figure 3. Schematic of 4156K and 4166K Series Temperature Controllers

## Principle of Operation

Figures 3, 4, and 5 show construction variations between the controllers. Table 1 relates construction variations to type numbers.

### Proportional-Only Controllers

Refer to figures 3 and 4.

As the process temperature increases, pressure increases within the Bourdon tube extending its radius of arc. This moves the flapper toward the nozzle (in a direct-acting controller) restricting flow

through the nozzle and increasing nozzle pressure. When this occurs, relay action increases the output pressure of the controller.

With a Type 4156K proportional-only controller, a portion of the output pressure is fed back to the proportional bellows. The action of the proportional bellows counters the flapper movement that resulted from the process temperature change and backs the flapper away from the nozzle until equilibrium is attained. The proportional band adjustment determines the amount of output pressure that is fed back to the proportional bellows. Adjusting the proportional band changes the gain of the controller.

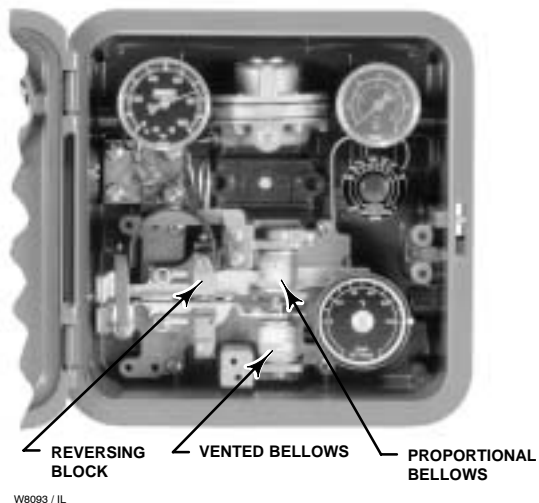

Figure 4. Direct-Acting Type 4156K Controller

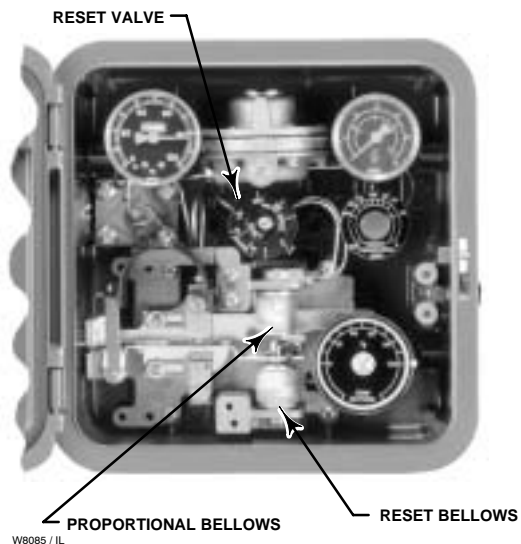

Figure 5. Direct-Acting Type 4166K Controller

The set point adjustment changes the proximity of the nozzle and flapper as does a change in process temperature. When the set point is changed, however, the nozzle moves with respect to the flapper.

As shown in figure 6, moving the reversing block and bellows connection changes the controller action from direct to reverse, and vice versa. With reverse-acting controllers, an increase in process temperature causes a decrease in output pressure.

## Proportional-Plus-Reset Controllers

Refer to figures 3 and 5.

Operation of the Type 4166K Proportional-plus-reset controller is similar to that of the proportional-only controller except that output pressure is fed back to the reset bellows, through a reset restriction valve, as well as to the proportional bellows. The action of the reset bellows opposes that of the proportional bellows. However, because of the reset restriction valve, the action of the reset pressure is delayed. The reset valve can be adjusted to vary the delay time. In operation, proportional-plus-reset controllers minimize the offset between the process temperature and set point.

## Anti-Reset Windup

The Type 4166KF controller has an adjustable and reversible differential relief valve to provide anti-reset windup. As shown in figure 3, the proportional pressure registers rapidly on the spring side of the relief valve diaphragm as well as in the proportional bellows. Reset pressure registers slowly on the opposite side of the relief valve diaphragm. As long as the controller output pressure changes are slow enough for normal proportional and reset action, the relief valve spring keeps the relief valve diaphragm from opening. However, a large or rapid decrease in controller output pressure decreases the pressure in the proportional system, and on the spring side of the relief diaphragm. If the decrease on the spring side of the diaphragm is greater than the relief valve spring setting, the diaphragm will move off the relief valve orifice and permit the reset pressure on the opposite side of the relief valve diaphragm to bleed rapidly into the proportional system. The differential relief valve can also be reversed to relieve with an increasing output pressure.

## Differential Gap Controllers

In the Type 4156KS controllers, feedback pressure does not counteract the change in flapper position. Instead, the output pressure is piped to the bellows located on the side of the beam and flapper opposite the nozzle. Feedback pressure now reinforces the flapper movement by the sensed temperature change. This construction causes the controller output to switch from full supply pressure to zero pressure or vice versa. The difference between the process temperature when the controller output switches to zero and the process temperature when the controller switches to maximum is the differential gap. Adjusting the proportional band adjustment adjusts the width of the gap; adjusting the set point positions the gap within the temperature element range.

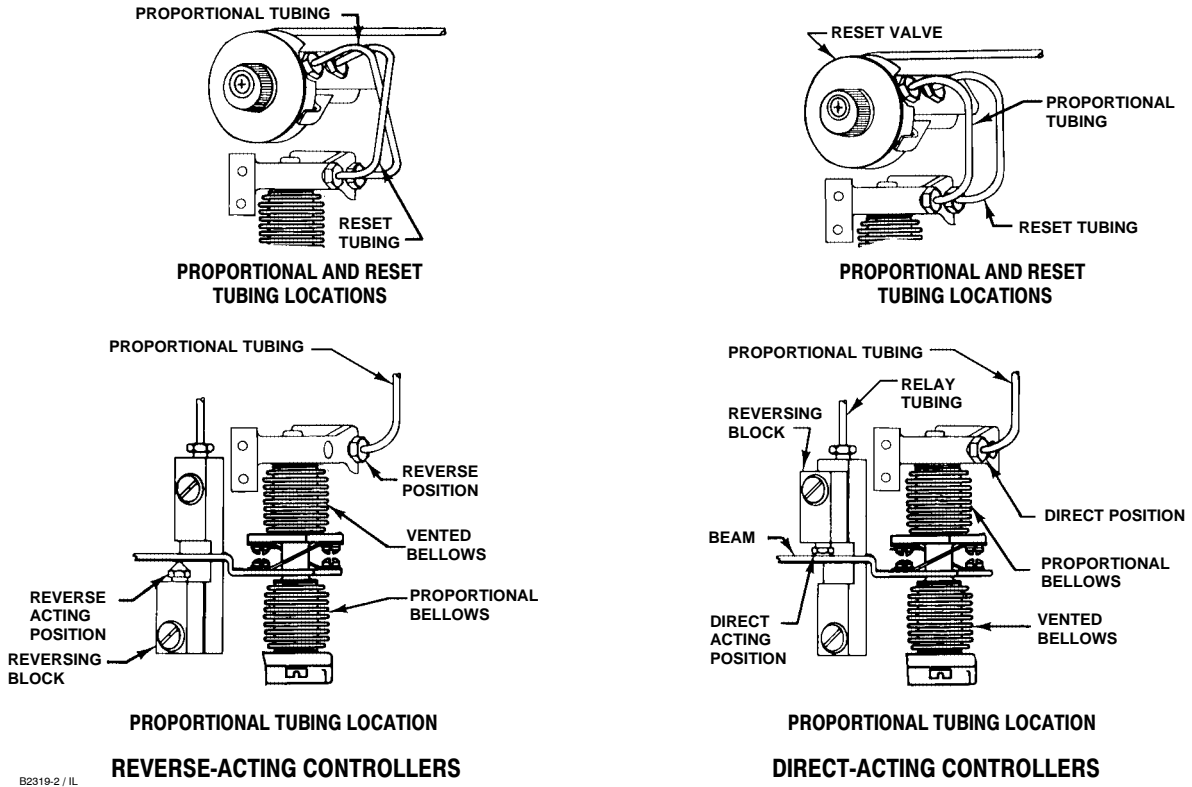

Figure 6. Converting from Direct to Reverse Action

**Construction Features**

**Easy Relay Maintenance**

A clean-out wire provides a fast, easy means of cleaning the primary orifice of the relay during service.

**Rugged Service Capability**

The case and cover are made of weather resistant die-cast aluminum. Internal constructions are available to resist corrosive supply pressure media such as sour gas.

**Easy Conversion from Proportional to Differential Gap**

When the application requires differential gap control, the Type 4156KS controller is available. Or, a proportional-only controller can be easily converted to differential gap operation by reversing the tubing connection at the bellows frame on top of the beam and flapper.

**Easy Direct/Reverse Conversion**

Switching the action from direct to reverse or vice versa is done by simply moving the reversing block and feedback bellows connection as shown in figure 6.

Table 6. Temperature Bulb Dimensions

SAMA STYLE	TEMPERATURE SPANS			B(1)		
	°C	°F				
Adjustable Union (Standard Construction)	0-100	0-100		1/2 NPSM-2B		
	0-150	200-400		1/2 NPSM-2B		
	0-200	0-400		1 UNEF-2B		
	0-500	0-1000		1 UNEF-2B		
	DIMENSION					
	J		X		Y	
mm	Inch	mm	Inch	mm	Inch	
445	17.50	145	5.70	10	0.38	
584	23.00	178	7.00	14	0.56	

1. NPSM--National Straight Pipe Threads for Mechanical Joints; UNEF--Unified Thread--Extra Fine

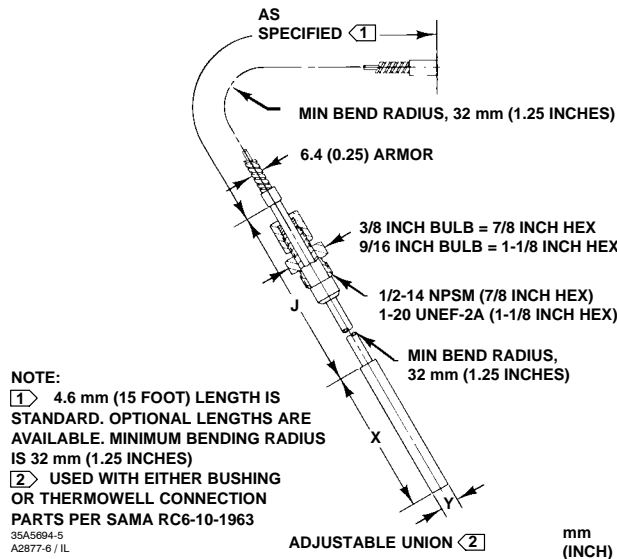

Figure 7. Temperature Bulb Dimensions (also see table 6)

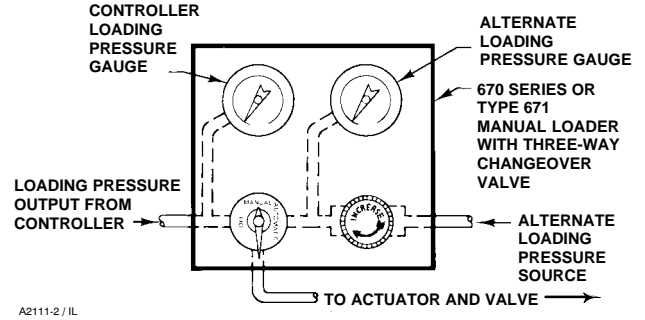

Figure 8. Schematic of Manual Backup Changeover Hookup for Wizard® II Controller

## Manual Backup

As shown in figure 8, a 670 or 671 Series panel-mounted loading regulator with changeover valve permits switching to an alternate loading pressure in the event of a supply pressure failure or other malfunction.

## Anti-Reset Windup

The anti-reset windup capability of the Type 4166KF controller provides quick equalization of reset and proportional pressures. This capability reduces overshoot of the process temperature that can result from large or prolonged deviation from set point.

The differential relief valve has a range of 0.14 to 0.4 bar (2 to 7 psig) and, unless ordered otherwise, is set by the factory to relieve at a 0.3 bar (5 psi) difference between proportional and reset pressures. The valve can be positioned to relieve on either increasing or decreasing output pressure.

**Product Bulletin**

34.6:4156K  
February 2007

**4156K and 4166K Controllers**

*Table 7. Bushing Dimensions*

TEMPERATURE BULB DIAMETER		A <sup>(1)</sup>	B		Without Lagging		With Lagging					
mm	Inch		mm	Inch	mm	Inch	C		D		E	
10	3/8	1/2-14 NPSM	11	0.44	11	0.44	12	0.47	113	4.44	11	0.44
14	9/16	1-20 UNEF	19	0.75	16	0.63	17	0.66	121	4.75	16	0.63

1. Seat area per SAMA Standard RC-17-10.

*Table 8. Thermowell Dimensions*

TEMPERATURE BULB DIAMETER		A	B		C <sup>(1)</sup>	U (INSERTION LENGTH)	
mm	Inch		mm	Inch		mm	Inch
10	3/8	1/2-14 NPT 3/4-14 NPT	16	0.63	1/2 14 NPSM-2B	191	7.5
						267	10.5
						406	16
14	9/16	3/4-14 NPT	22	0.88	1-20 UNEF-2B	191	7.5
						267	10.5
						406	16
						559	24

1. Seat area per SAMA Standard RC-17-10.

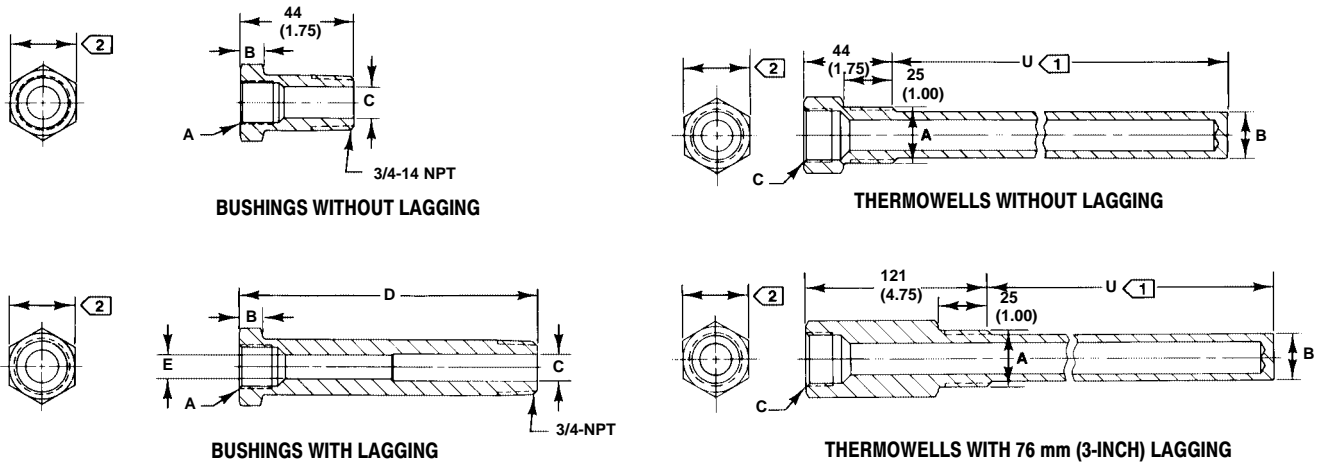

**NOTES:**  
 [1] TOLERANCES FOR THIS DIMENSION ARE AS FOLLOWS:  
 1.5 mm (±0.06 INCH) WHEN LENGTH IS 305 mm (12 INCHES) OR LESS  
 3.2 mm (±0.125 INCH) WHEN LENGTH IS GREATER THAN 305 mm (12 INCHES)  
 [2] 1-1/8 INCH HEX FOR 3/8-INCH TEMPERATURE BULB;  
 1-1/4 INCH HEX FOR 9/16-INCH TEMPERATURE BULB  
 A3240-0\* / IL

*Figure 9. Bushing and Thermowell Dimensions (also see tables 7 and 8)*

# 4156K and 4166K Controllers

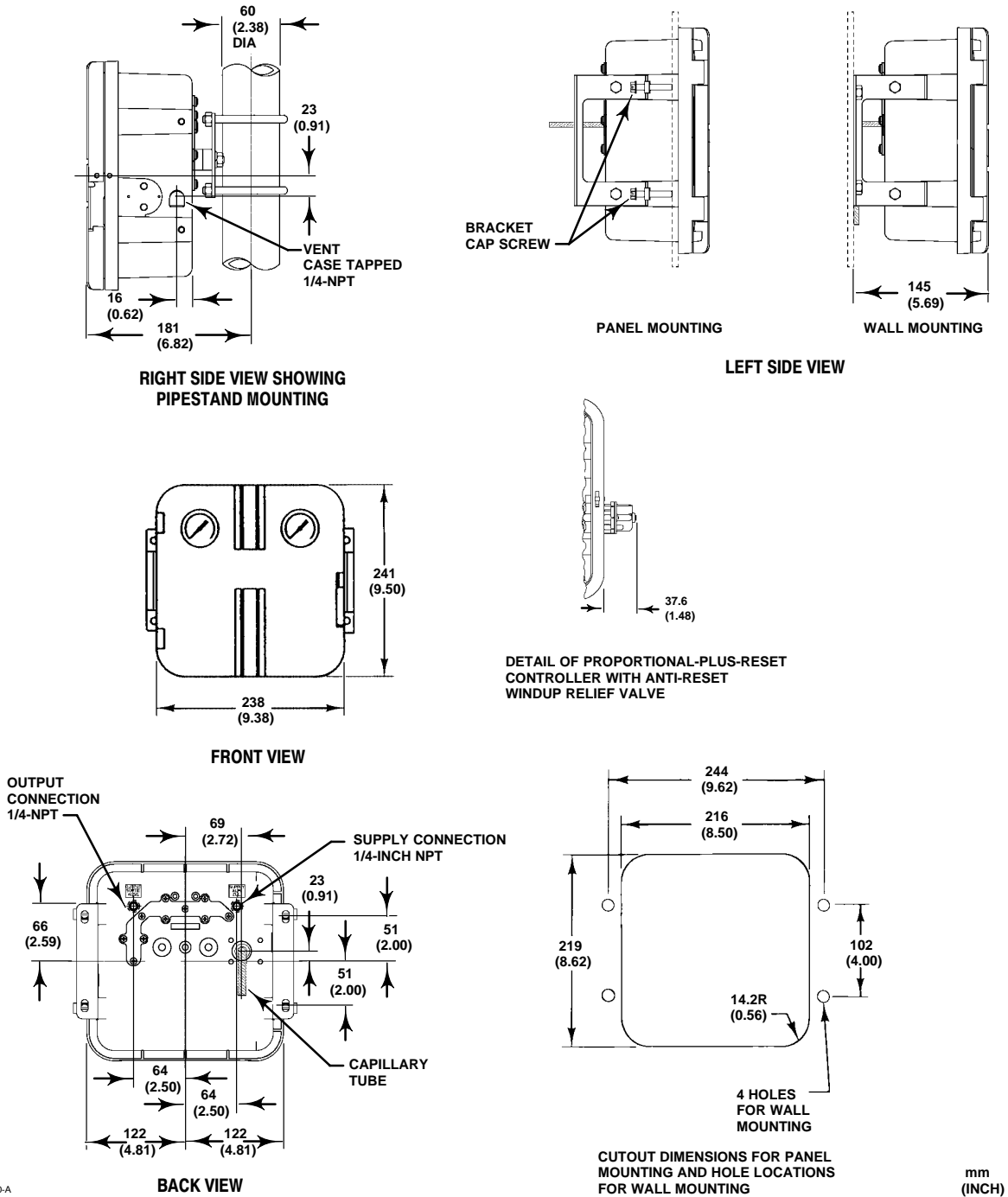

19B3110-A  
15A7451-C  
15A7452-F  
B2320-3 / IL  
GE07082-A

Figure 10. Controller Dimensions

## Installation

Process temperature is sensed by a temperature bulb immersed in the process fluid. Temperature bulb dimensions are shown in figure 7 and table 6. Mounting the temperature bulb in a closed vessel requires a bushing or thermowell. Figure 9 and tables 7 and 8 show the dimensions of various bushings and thermowells available. When the temperature bulb is used within a closed vessel, the bulb screws into a bushing that penetrates the vessel. If the pressure within the closed vessel exceeds the limits of the temperature bulb, or if the process fluid is corrosive, the temperature bulb screws into a thermowell that penetrates the vessel. Lag type bushings and thermowells are used where extra length is required, such as installation in a process vessel that is coated with insulation.

The controller must be installed within the capillary tube length of the temperature bulb. Basic controller dimensions as well as dimensions for specific mounting configurations are shown in figure 10. Install the controller so that the vent points down.

These temperature controllers are often mounted on the actuator of a control valve. Typical yoke mounting of a controller and regulator on a control valve actuator is shown in figure 11.

## Ordering Information

When ordering, specify:

### Application

1. Description of the service
2. Temperature range of the process
3. Ambient temperature
4. Velocity of process fluid (if measuring the temperature of a process fluid flowing through a pipe)
5. Pressure in process vessel (if closed)

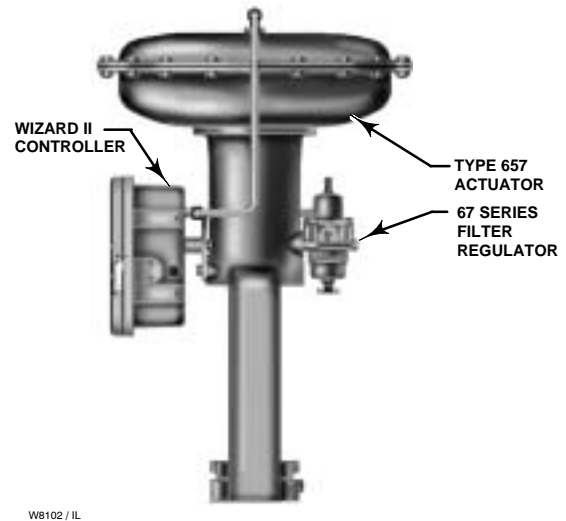

Figure 11. Typical Yoke Mounting

6. Bushing or thermowell (when the temperature bulb is to be used in a closed vessel). Refer to figure 8 for available sizes. Specify straight shank or tapered shank thermowell. (Tapered-shank thermowells, with their high strength-to-weight ratio, permit operation in higher process fluid velocities than do straight-shank thermowells.)

## Construction

Refer to the specifications and the Construction Features section. Review each specification and feature, specifying your choice whenever a selection is offered. A panel mounting bracket is supplied unless some other mounting method is specified.

Specify the quantity and the complete type number (including the R suffix for reverse action) for the Wizard II controller.

### Note

**Neither Emerson, Emerson Process Management, nor any of their affiliated entities assumes responsibility for the selection, use, and maintenance of any product. Responsibility for the selection, use, and maintenance of any product remains with the purchaser and end-user.**

# 4156K and 4166K Controllers

**Product Bulletin**

34.6:4156K  
February 2007

---

Wizard and Fisher are marks owned by Fisher Controls International LLC, a member of the Emerson Process Management business division of Emerson Electric Co. Emerson Process Management, Emerson, and the Emerson logo are trademarks and service marks of Emerson Electric Co. All other marks are the property of their respective owners.

*The contents of this publication are presented for informational purposes only, and while every effort has been made to ensure their accuracy, they are not to be construed as warranties or guarantees, express or implied, regarding the products or services described herein or their use or applicability. We reserve the right to modify or improve the designs or specifications of such products at any time without notice.*

Neither Emerson, Emerson Process Management, nor any of their affiliated entities assumes responsibility for the selection, use and maintenance of any product. Responsibility for the selection, use and maintenance of any product remains with the purchaser and end-user.

**Emerson Process Management**

Marshalltown, Iowa 50158 USA

Cernay 68700 France

Sao Paulo 05424 Brazil

Singapore 128461

[www.Fisher.com](http://www.Fisher.com)

