

Fisher® POSI-SEAL™ A31A High-Performance Butterfly Valve

The Fisher A31A High Performance Butterfly Valve provides outstanding performance under extreme pressure and temperature conditions. The A31A valve maintains tight shutoff and is available in a fire-tested version.

The A31A valve is available as either a flangeless (wafer style) design or as a single-flange (lugged) design. A keyed drive shaft combines with a variety of hand levers, handwheels, or pneumatic piston diaphragm actuators to make the A31A a reliable, high-performance butterfly valve for a variety of on-off applications in the various process industries.

The A31A valve can be supplied with one of several dynamic seals (figure 1) that can be used in a variety of demanding applications. With the appropriate seal selection and materials of construction, the pressure-assisted seal provides excellent shutoff against the full ASME class pressure range for the specific valve type.

Unless otherwise noted, all NACE references are to NACE MR0175-2002.

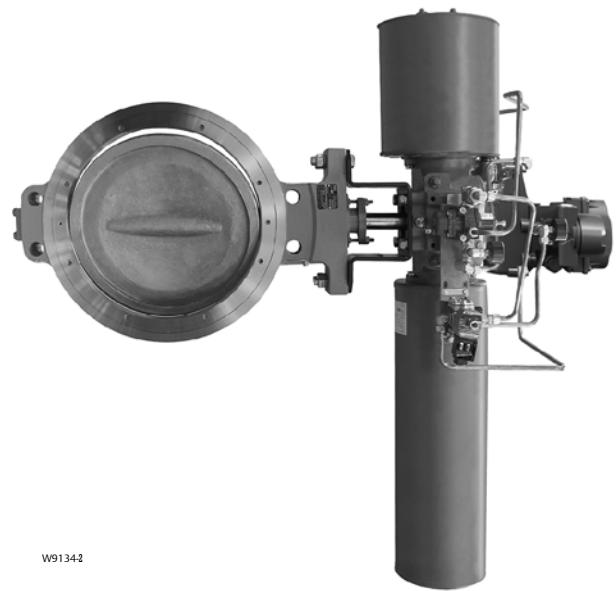

W91344

**FISHER A31A VALVE WITH BETTIS™ ACTUATOR AND
DVC6200 FIELDVUE™ DIGITAL VALVE CONTROLLER**



Specifications

Valve Sizes⁽¹⁾

NPS ■ 14, ■ 16, ■ 18, ■ 20, and ■ 24

Available Valve Configurations

■ Flangeless (wafer) style or ■ single-flange (lugged) control valve with a one-piece valve body, a two-component seal/backup O-ring, and a keyed drive shaft

End Connection Style

■ Flangeless style or ■ single flange valve body designed to fit between raised-face mating flanges per ASME B16.5 CL150 or CL300

Valve Body Classification

Face-to-face dimensions are in compliance with MSS SP68 and API 609 standards; valve bodies are designed for installation between ASME B16.5 CL150 or CL300 raised-face flanges

Maximum Inlet Pressure/Temperature⁽²⁾

Consistent with ■ CL150 and ■ CL300 pressure/temperature ratings per ASME B16.34. Also, see figure 2 for additional information

Available Seal Configurations

See figure 1 and table 1

Standard Construction Materials

See table 1

Disc Coating

Hardcoating (also see table 1)

■ Standard when used with NOVEX seal or Phoenix III seal.

Shaft Extension Lengths

■ None required for temperatures less than 343°C (650°F), ■ 152.4 mm (6 inches) for temperatures

from 343 to 538°C (650 to 1000°F), or ■ 304.8 mm (12 inches) for temperatures above 538°C (1000°F)

Shutoff Classification per ANSI/FCI 70-2 and IEC 60534-4

Standard Soft Seal: Bidirectional bubble-tight shutoff
NOVEX Seal: Unidirectional shutoff MSS-SP61 (preferred flow direction only⁽³⁾), optional Class VI
Phoenix III Seal: Bidirectional bubble-tight
Phoenix III Seal for Fire Tested Applications: Shutoff per FCI 70-2 Class VI. Fire Tested per API 607 Rev. 4. Contact your Emerson Process Management sales office for more information.

Flow Characteristic

Modified equal percentage

Flow Coefficients and Noise Levels

See the section titled Coefficients in this bulletin and Catalog 12

Available Actuators

Handlever, handwheel, or pneumatic piston

Disc Rotation

Clockwise (CW) to close

Valve Dimensions and Approximate Weights

See figures 5, 6, 7 and 8

Options

ENVIRO-SEAL™ PTFE or graphite packing system provides improved sealing, guiding, and transmission of loading force to control liquid and gas emissions. See Bulletin 59.3:041 ENVIRO-SEAL Packing Systems for Rotary Valves for more information.

Cryogenic extension and seal provides service down to -234°C (-425°F). See Bulletin 21.1:Cryogenic-Rotary for more information.

1. The valve sizes listed in this bulletin refer to Nominal Pipe Size (NPS).

2. The pressure/temperature limits in this bulletin (figure 2), and any application code or standard limitation, should not be exceeded.

3. For optimum seal performance, the preferred valve orientation at shutoff is with the retaining ring downstream from the high pressure side of the valve.

Features

- **Economical Tight Shutoff**—The pressure-assisted seal design provides tight shutoff and permits the use of smaller, less expensive actuators in applications requiring full ASME B16.34 shutoff capabilities.
- **Excellent Shutoff Integrity**—Concentric rotation helps to ensure that the valve disc remains in the closed position in spite of line pressure surges or actuator failure.
- **True Bi-directional Shutoff Performance**—Valve design helps to ensure that the torque necessary to open and close the valve is the same regardless of the direction in which the differential pressure is applied.
- **Safety**—Shaft blowout protection is designed into the A31A valve (figure 3). The anti-blowout gland fits securely over the valve shaft which has been turned down to form a circumferential shoulder that contacts the anti-blowout gland.
- **Ease of Maintenance**—Interchangeability of all parts including shafts and discs simplifies service and reduces maintenance costs.
- **Improved Environmental Capabilities**—The optional ENVIRO-SEAL packing system is designed with improved sealing, guiding, and loading force transmission. The ENVIRO-SEAL packing system can control emissions to below the EPA (Environmental Protection Agency) limit of 100 ppm (parts per million) for valves.
- **Reliable Flange Gasketing Surface**—Seal retainer screws are located so there is no interference with the sealing function of either flat sheet or spiral wound line flange gaskets.

- **Easy Installation**—The valve body self-centers on the line flange bolts as a fast, accurate means of centering the valve in the pipeline.

Figure 1. Available Seal Configurations

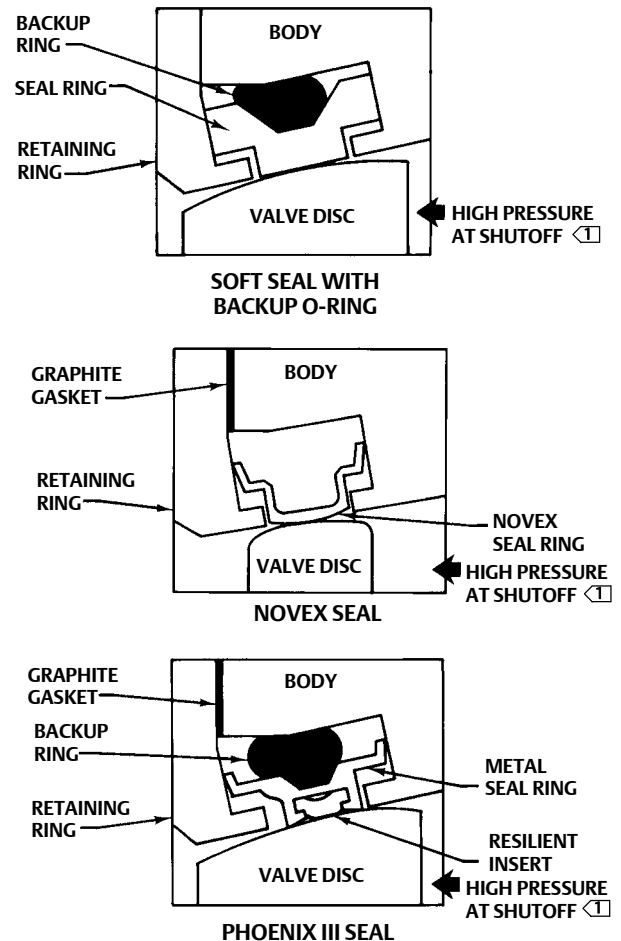

NOTE:
 □ FOR OPTIMUM SEAL PERFORMANCE, THE PREFERRED VALVE ORIENTATION AT SHUTOFF IS WITH THE RETAINING RING DOWNSTREAM FROM THE HIGH PRESSURE SIDE OF THE VALVE.

B2334-1

Figure 2. Maximum Pressure/Temperature Ratings

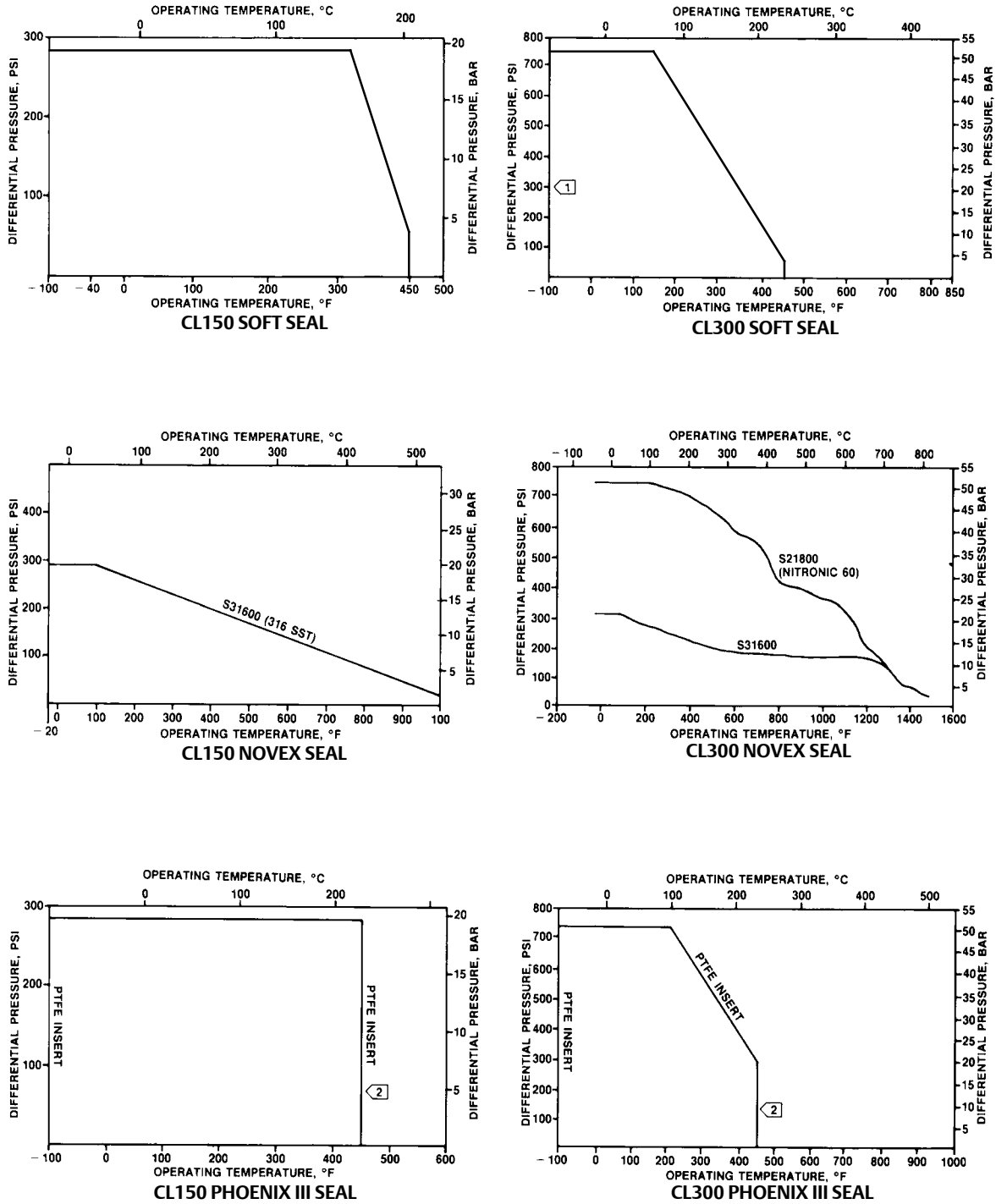

C0759-2

NOTE:

- 1) DO NOT THROTTLE PTFE SEALS AT DIFFERENTIAL PRESSURES GREATER THAN 21 BAR (300 PSID) AT DISC ANGLES LESS THAN 20° OPEN. THROTTLING PIPE SEALS UNDER SUCH CONDITIONS MAY CAUSE EROSION AND SEAL FAILURE.
- 2) TEMPERATURE LIMITATIONS DO NOT ACCOUNT FOR THE ADDITIONAL LIMITATIONS IMPOSED BY THE BACKUP O-RING USED WITH THIS SEAL. TO DETERMINE THE EFFECTIVE TEMPERATURE LIMITATION OF THE APPROPRIATE SEAL/BACKUP O-RING COMBINATION, REFER TO TABLE 2.

Figure 3. Blowout Protection

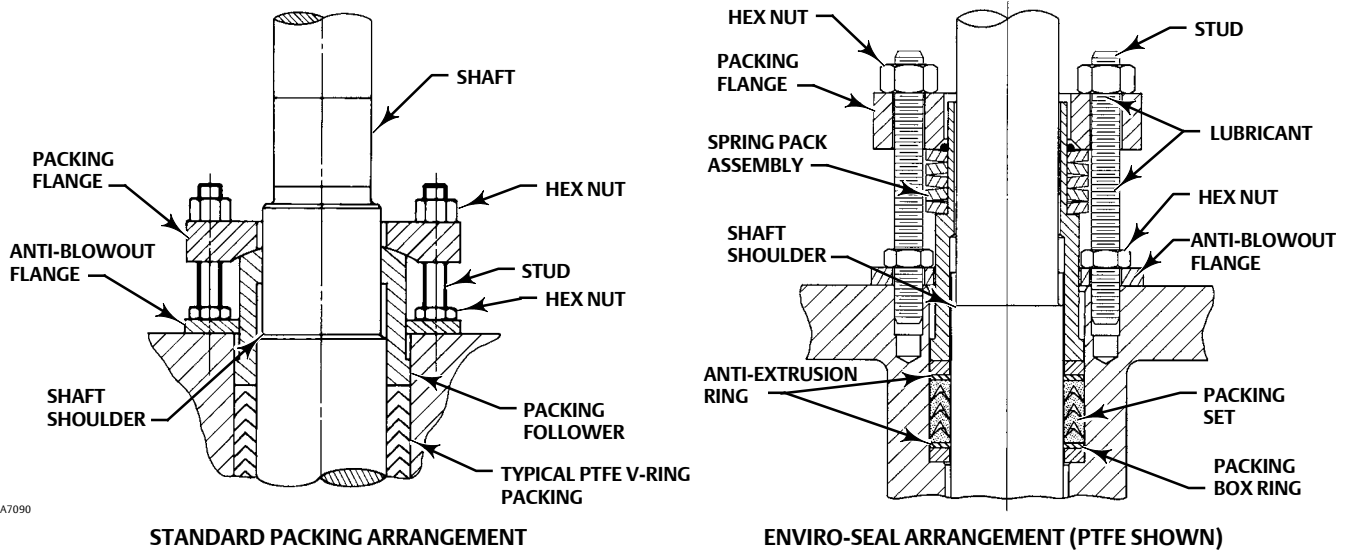

A7090

Figure 4. Typical Valve Assembly

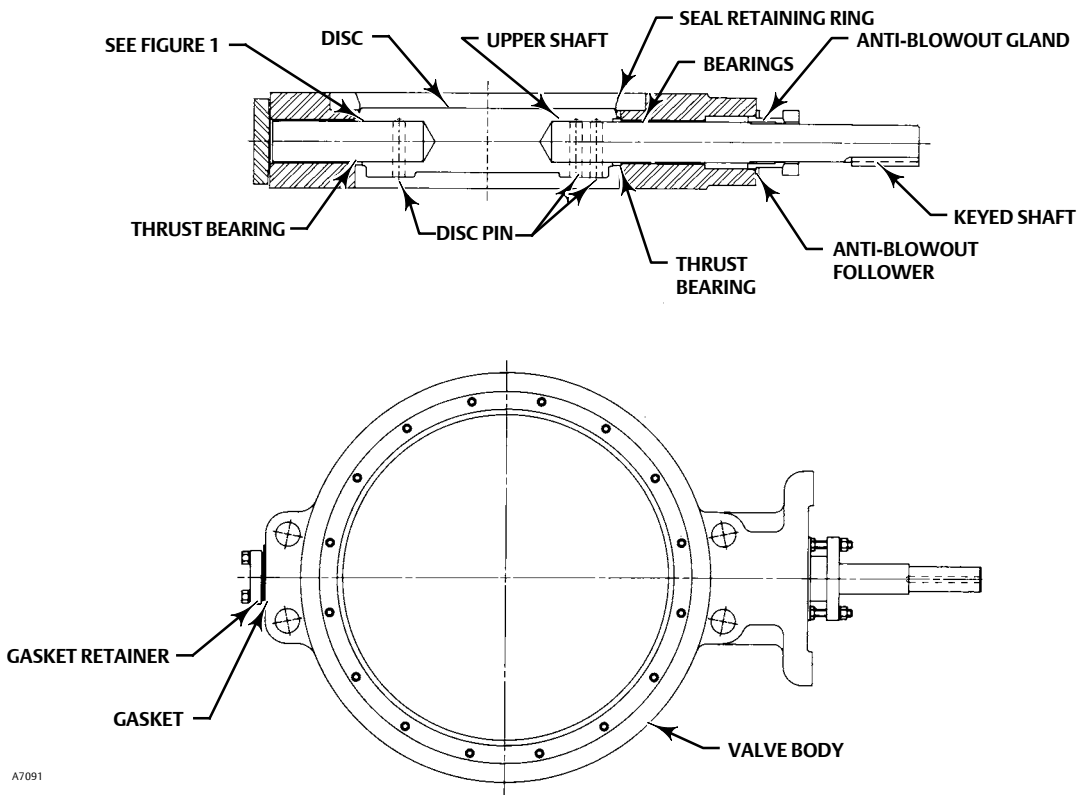

A7091

Table 1. Materials of Construction and Temperature Ratings

COMPONENT AND MATERIAL OF CONSTRUCTION ⁽¹⁾		TEMPERATURE RANGE	
		°C	°F
Valve Body⁽²⁾ Carbon steel (WCC or SA 517-70) ⁽⁷⁾ CF8M (316 SST) CL150 and 300 CF8M ⁽³⁾ FMS 20B16 a Fisher material standard (0.04% min carbon) CL300		-29 to 427 -198 to 538 over 538 to 816	-20 to 800 -325 to 1000 over 1000 to 1500
Disc WCC carbon steel, for NPS 14 through 24 CF8M (316 SST) CF8M ⁽³⁾ FMS 20B16 a Fisher material standard (0.04% min carbon) CL300		-29 to 427 -198 to 538 over 538 to 816	-20 to 800 -325 to 1000 over 1000 to 1500
Disc Coating Chromium Carbide Chrome Plating Chromium Coating Electroless Nickel Coating (ENC)		-198 to 916 -254 to 316 -254 to 593 -254 to 343	-325 to 1500 -425 to 600 -425 to 1100 -425 to 650
Shaft S20910 S17400 (17-4 pH 1025) S17400 (17-4 pH H1150M) N07718 N07750		-198 to 538 -73 to 427 -196 to 427 -254 to 704 over 593 to 816	-325 to 1000 -100 to 800 -320 to 800 -425 to 1300 over 1100 to 1500
Bearings⁽⁶⁾ PEEK (standard) S31600 ⁽⁴⁾ R30006 (Alloy 6) Bronze		-73 to 260 -198 to 816 -198 to 816 -254 to 302	-100 to 500 -325 to 1500 -325 to 1500 -425 to 575
Packing PTFE Packing and PTFE ENVIRO-SEAL Packing Graphite packing Graphite packing with oxidizing media Graphite ENVIRO-SEAL Packing		-148 to 232 -198 to 916 -198 to 538 -148 to 315	-325 to 450 -325 to 1500 -325 to 1000 -325 to 600
Seal Ring and Backup Ring	PTFE Seal Ring Nitrile Backup O-Ring Chloroprene Backup O-Ring EPR Backup O-Ring Fluorocarbon Backup O-Ring PTFE Backup O-Ring	-29 to 93 -43 to 149 -54 to 182 -29 to 204 -73 to 204	-20 to 200 -45 to 300 -65 to 360 -20 to 400 -100 to 400
	UHMWPE⁽⁵⁾ Seal Ring (CL150 Only) Nitrile Backup O-Ring Chloroprene Backup O-Ring EPR Backup O-Ring Fluorocarbon Backup O-Ring PTFE Backup O-Ring	-29 to 93 -43 to 93 -54 to 93 -29 to 93 -73 to 93	-20 to 200 -45 to 200 -65 to 200 -20 to 200 -100 to 200
	Phoenix III and/or Fire Tested Construction S31600 and PTFE Seal Ring with Nitrile Backup O-Ring Chloroprene Backup O-Ring EPR Backup O-Ring Fluorocarbon Backup O-Ring	-40 to 149 -54 to 149 -62 to 204 -40 to 232	-40 to 300 -65 to 300 -80 to 400 -40 to 450
Seal Ring	NOVEX S31600 Seal ⁽⁴⁾ Ring (CL150) NOVEX S31600 Seal ⁽⁴⁾ Ring (CL300) NOVEX S21800 Seal ⁽⁴⁾ Ring (CL300)	-29 to 816 -29 to 816 -29 to 816	-20 to 1500 -20 to 1500 -20 to 1500

1. NACE trim constructions are available; consult your Emerson Process Management sales office.

2. Special gasket retainer bolts are required for over 482°C (900°F)

3. Special retaining ring screws for single flange valves over 538°C (1000°F)

4. For a complete material description, contact your Emerson Process Management sales office.

5. UHMWPE stands for ultra high molecular weight polyethylene.

6. Special thrust bearings are required for high temp. applications over 343°C (650°F) (with 6 and 12-inch shaft extensions). Constructions with carbon steel valves and SST discs may require special thrust bearings at temps. less than 343°C (650°F).

7. Cast or wrought/plate grades used interchangeably, depending on availability, unless specified by customer.

Table 2. Dimensions and Weights, Wafer Style Valves, CL150

Valve Size, NPS	A ⁽¹⁾	D	E	G	K	M ⁽²⁾ Min. I.D.	R	S (Shaft Dia at Keyway)	Key SQ Size	T	U	W	Y	Approx Weight
mm														kg
14	91.9	146	63.5	295	327	331	422	30.2	6.35	235	46.0	17.5	---	72
16	102	146	63.5	318	371	375	470	31.8	6.35	235	46.0	17.5	28.4	94
18	114	229	79.50	349	400	419	533	38.1	9.53	273	50.8	20.6	31.8	139
20	127	229	79.50	381	432	464	584	44.5	9.53	273	50.8	20.6	31.8	167
24	154	254	104.9	438	492	581	692	57.2	12.7	337	76.2	23.9	35.1	255
Inches														Pounds
14	3.62	5.75	2.5	11.62	12.88	13.04	16.62	1-3/16	0.25	9.25	1.81	0.69	---	158
16	4.00	5.75	2.5	12.50	14.62	14.77	18.50	1-1/4	0.25	9.25	1.81	0.69	1.12	207
18	4.50	9.00	3.13	13.75	15.75	16.49	21.00	1-1/2	0.375	10.75	2.00	0.81	1.25	307
20	5.00	9.00	3.13	15.00	17.00	18.27	23.00	1-3/4	0.375	10.75	2.00	0.81	1.25	368
24	6.06	10.00	4.13	17.25	19.38	22.87	27.25	2-1/4	0.5	13.25	3.00	0.94	1.38	563

1. Face-to-face dimensions are in compliance with MSS SP68 and API 609 specifications.
2. Minimum I.D. is the minimum pipe or flange I.D. required for disc swing clearance.

Figure 5. Dimensions and Weights, Wafer Style Valves, CL150 (also see table 2)

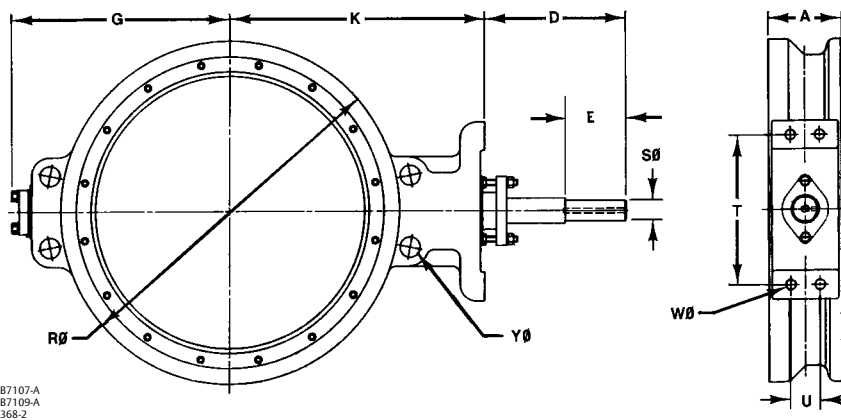

12B7107-A
12B7109-A
B2368-2

NOTE: THE KEYWAY IS SHOWN ON THIS SIDE OF THE SHAFT FOR REFERENCE PURPOSES ONLY.

Table 3. Dimensions and Weights, Single Flange Valves, CL150

Valve Size, NPS	A ⁽¹⁾	D	E	G	K	M ⁽²⁾ Min. I.D.	R	S (Shaft Dia at Keyway)	Key SQ Size	T	U	W	Y	Approx Weight
mm														kg
14	91.9	146	63.5	295	327	331	531	30.2	6.35	235	46.0	17.5	---	95
16	102	146	63.5	318	371	375	607	31.8	6.35	235	46.0	17.5	---	138
18	114	229	79.50	349	400	419	645	38.1	9.53	273	50.8	20.1	---	178
20	127	229	79.50	381	432	464	696	44.5	9.53	273	50.8	20.1	---	224
24	154	254	104.9	438	492	581	822	57.2	12.7	337	76.2	23.9	---	315
Inches														Pounds
14	3.62	5.75	2.5	11.62	12.88	13.04	20.88	1-3/16	0.25	9.25	1.81	0.69	1-8 12 Holes	209
16	4.00	5.75	2.5	12.50	14.62	14.77	23.88	1-1/4	0.25	9.25	1.81	0.69	1-8 16 Holes	304
18	4.50	9.00	3.13	13.75	15.75	16.49	25.38	1-1/2	0.38	10.75	2.00	0.81	1-1/8-8 16 Holes	393
20	5.00	9.00	3.13	15.00	17.00	18.27	27.38	1-3/4	0.38	10.75	2.00	0.81	1-1/8-8 20 Holes	493
24	6.06	10.00	4.13	17.25	19.38	22.87	32.38	2-1/4	0.5	13.25	3.00	0.94	1-1/4-8 20 Holes	773

1. Face-to-face dimensions are in compliance with MSS SP68 and API 609 specifications.
2. Minimum I.D. is the minimum pipe or flange I.D. required for disc swing clearance.

Figure 6. Dimensions and Weights, Single Flange Valves, CL150 (also see table 3)

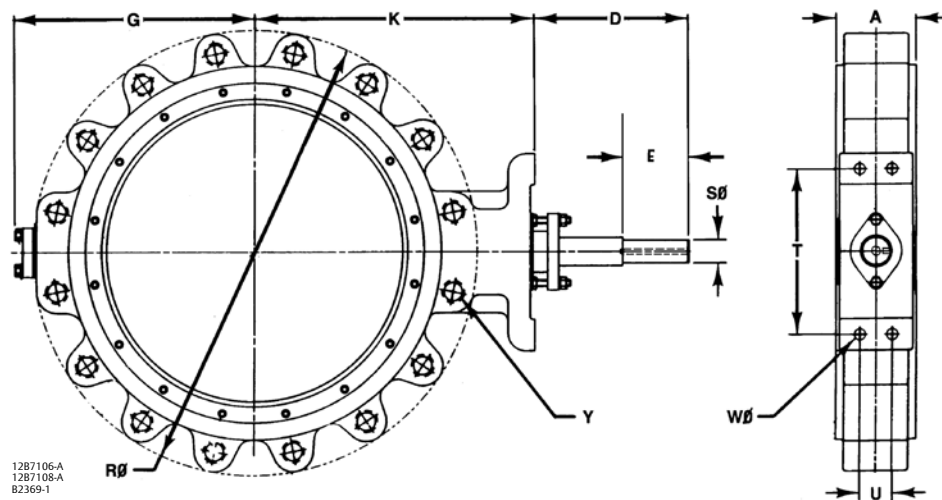

NOTE: THE KEYWAY IS SHOWN ON THIS SIDE OF THE SHAFT FOR REFERENCE PURPOSES ONLY.

Installation

Recommended installation for the A31A valve is with the shaft upstream of the seal (retaining ring downstream from the high pressure side of the valve).

The standard soft seal offers bubble-tight, bidirectional shutoff. To meet the performance requirements of many of today's fire-tested requirements, a Phoenix III valve must be installed in the preferred valve

orientation. The NOVEX seals are uni-directional and should be installed with the shaft upstream of the seal.

For assistance in selecting the appropriate combination of actuator action and open valve position, consult your Emerson Process Management sales office.

Dimensions and weights for wafer-style and single-flange valves are shown in figures 5, 6, 7 and 8.

Table 4. Dimensions and Weights, Wafer Style Valves, CL300

Valve Size, NPS	A ⁽¹⁾	D	E	G	K	M ⁽²⁾ Min. I.D.	R	S (Shaft Dia at Keyway)	Key SQ Size	T	U	W	Y	Approx Weight
mm														kg
14	117	229	79.50	319	364	304	437	44.5	9.53	273	50.8	20.6	---	121
16	133	229	79.50	353	397	346	498	44.5	9.53	273	50.8	20.6	---	183
18	149	254	104.9	384	419	389	556	57.2	12.7	337	76.2	23.9	---	227
20	159	273	124.0	416	483	442	605	69.9	15.88	337	76.2	23.9	---	364
24	181	273	124.0	483	546	523	716	69.9	15.88	337	76.2	23.9	---	469
Inches														Pounds
14	4.62	9.00	3.13	12.56	14.31	11.98	17.19	1-3/4	0.375	10.75	2.00	0.81	1-1/8-8 4 Holes	266
16	5.25	9.00	3.13	13.88	15.62	13.63	19.62	1-3/4	0.375	10.75	2.00	0.81	1-1/4-8 4 Holes	403
18	5.88	10.00	4.13	15.12	16.50	15.32	21.88	2-1/4	0.5	13.25	3.00	0.94	1-1/4-8 4 Holes	500
20	6.25	10.75	4.88	16.38	19.00	17.40	23.81	2-3/4	0.625	13.25	3.00	0.94	1-1/4-8 4 Holes	802
24	7.12	11.75	4.88	19.00	21.50	20.59	28.19	2-3/4	0.625	13.25	3.00	0.94	1-1/2-8 4 Holes	1035

1. Face-to-face dimensions are in compliance with MSS SP68 and API 609 specifications.
2. Minimum I.D. is the minimum pipe or flange I.D. required for disc swing clearance.

Figure 7. Dimensions and Weights, Wafer Style Valves, CL300 (also see table 4)

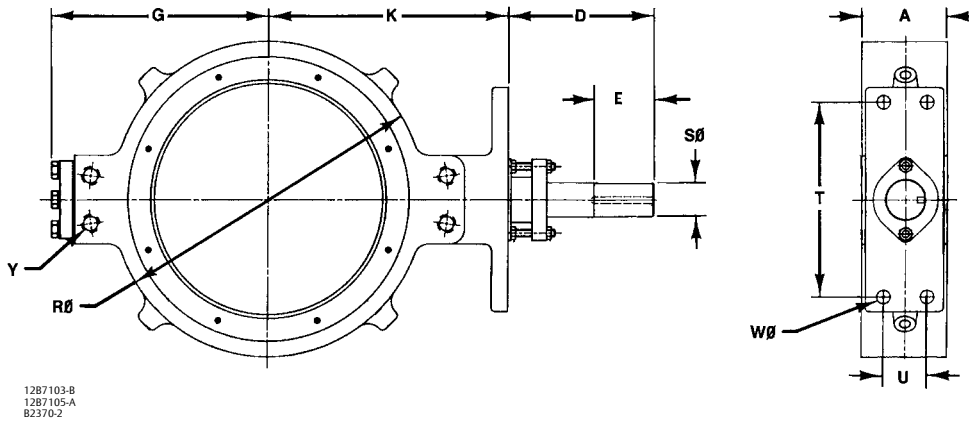

1287103-B
1287105-A
82370-2

NOTE: THE KEYWAY IS SHOWN ON THIS SIDE OF THE SHAFT FOR REFERENCE PURPOSES ONLY.

Table 5. Dimensions and Weights, Single Flange Valves, CL300

Valve Size, NPS	A ⁽¹⁾	D	E	G	K	M ⁽²⁾ Min. I.D.	R	S (Shaft Dia at Keyway)	Key SQ Size	T	U	W	Y	Approx Weight
mm														kg
14	117	229	79.50	319	364	304	594	44.5	9.53	273	50.8	20.6	---	227
16	133	229	79.50	353	397	346	657	44.5	9.53	273	50.8	20.6	---	294
18	149	254	104.9	384	419	389	721	57.2	12.7	337	76.2	23.9	---	402
20	159	273	124.0	416	483	442	784	69.9	15.88	337	76.2	23.9	---	544
24	181	292	124.0	483	546	523	924	69.9	15.88	337	76.2	23.9	---	821
Inches														Pounds
14	4.62	9.00	3.13	12.56	14.31	11.98	23.38	1-3/4	0.375	10.75	2.00	0.81	1-1/8-8 16 Holes	500
16	5.25	9.00	3.13	13.88	15.62	13.63	25.88	1-3/4	0.375	10.75	2.00	0.81	1-1/4-8 20 Holes	649
18	5.88	10.00	4.13	15.12	16.50	15.32	28.38	2-1/4	0.5	13.25	3.00	0.94	1-1/4-8 24 Holes	886
20	6.25	10.75	4.88	16.38	19.00	17.40	30.88	2-3/4	0.625	13.25	3.00	0.94	1-1/4-8 24 Holes	1200
24	7.12	11.50	4.88	19.00	21.50	20.59	36.38	2-3/4	0.625	13.25	3.00	0.94	1-1/2-8 24 Holes	1810

1. Face-to-face dimensions are in compliance with MSS SP68 and API 609 specifications.
2. Minimum I.D. is the minimum pipe or flange I.D. required for disc swing clearance.

Figure 8. Dimensions and Weights, Single Flange Valves, CL300 (also see table 5)

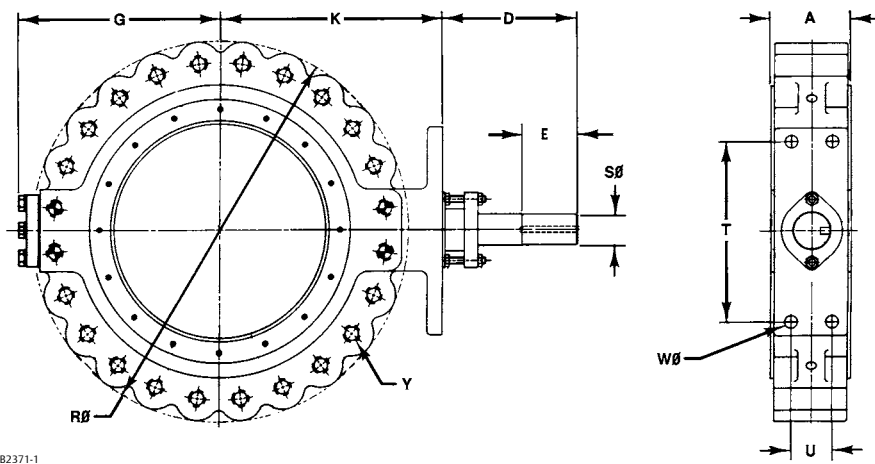

NOTE: THE KEYWAY SHOWN ON THIS SIDE OF THE SHAFT FOR REFERENCE PURPOSES ONLY.

Coefficients

Table 6. CL150, Reverse Flow

Coefficients	Valve Size, NPS	Valve Rotation, Degrees								
		10	20	30	40	50	60	70	80	90
C_v	14	95	316	695	1200	1900	2840	3980	5120	6320
K_v		82.2	273	601	1038	1643	2457	3443	4429	5467
F_d		0.090	0.17	0.26	0.34	0.42	0.49	0.57	0.64	0.70
F_L		0.77	0.79	0.81	0.81	0.78	0.73	0.68	0.60	0.52
X_T		0.50	0.53	0.55	0.55	0.51	0.45	0.39	0.30	0.23
C_v	16	129	430	946	1640	2580	3870	5420	6970	8600
K_v		112	372	818	1419	2232	3348	4688	6029	7439
F_d		0.090	0.17	0.26	0.34	0.42	0.49	0.57	0.64	0.70
F_L		0.77	0.79	0.81	0.81	0.78	0.73	0.68	0.60	0.52
X_T		0.50	0.53	0.55	0.55	0.51	0.45	0.39	0.30	0.23
C_v	18	166	553	1220	2100	3320	4970	6960	8950	11050
K_v		144	478	1055	1817	2872	4299	6020	7742	9558
F_d		0.090	0.17	0.26	0.34	0.42	0.49	0.57	0.64	0.70
F_L		0.77	0.79	0.81	0.81	0.78	0.73	0.68	0.60	0.52
X_T		0.50	0.53	0.55	0.55	0.51	0.45	0.39	0.30	0.23
C_v	20	208	692	1520	2630	4160	6230	8730	11,220	13850
K_v		180	599	1315	2275	3598	5389	7551	9705	11980
F_d		0.090	0.17	0.26	0.34	0.42	0.49	0.57	0.64	0.70
F_L		0.77	0.79	0.81	0.81	0.78	0.73	0.68	0.60	0.52
X_T		0.50	0.53	0.55	0.55	0.51	0.45	0.39	0.30	0.23
C_v	24	322	1080	2370	4080	6450	9670	13,540	17,410	21500
K_v		277	934	2050	3529	5579	8365	11712	15060	18598
F_d		0.090	0.17	0.26	0.34	0.42	0.49	0.57	0.64	0.70
F_L		0.77	0.79	0.81	0.81	0.78	0.73	0.68	0.60	0.52
X_T		0.50	0.53	0.55	0.55	0.51	0.45	0.39	0.30	0.23

Table 7. CL300, Reverse Flow

Coefficients	Valve Size, NPS	Valve Rotation, Degrees								
		10	20	30	40	50	60	70	80	90
C _v	14	136	341	704	1200	1860	2680	3450	4050	4550
K _v		118	295	609	1038	1609	2318	2984	3503	3936
F _d		0.090	0.17	0.26	0.34	0.42	0.49	0.57	0.64	0.70
F _L		0.78	0.81	0.81	0.79	0.75	0.69	0.62	0.56	0.52
X _T		0.51	0.55	0.55	0.53	0.47	0.40	0.33	0.26	0.23
C _v	16	169	422	873	1490	2310	3320	4280	5010	5630
K _v		146	365	755	1289	1998	2872	3702	4334	4870
F _d		0.090	0.17	0.26	0.34	0.42	0.49	0.57	0.64	0.70
F _L		0.78	0.81	0.81	0.79	0.75	0.69	0.62	0.56	0.52
X _T		0.51	0.55	0.55	0.53	0.47	0.40	0.33	0.26	0.23
C _v	18	247	617	1280	2180	3370	4860	6260	7330	8230
K _v		214	534	1107	1886	2915	4204	5415	6340	7119
F _d		0.090	0.17	0.26	0.34	0.42	0.49	0.57	0.64	0.70
F _L		0.78	0.81	0.81	0.79	0.75	0.69	0.62	0.56	0.52
X _T		0.51	0.55	0.55	0.53	0.47	0.40	0.33	0.26	0.23
C _v	20	286	714	1480	2520	3910	5620	7240	8480	9530
K _v		247	618	1280	2180	3382	4861	6263	7335	8243
F _d		0.090	0.17	0.26	0.34	0.42	0.49	0.57	0.64	0.70
F _L		0.78	0.81	0.81	0.79	0.75	0.69	0.62	0.56	0.52
X _T		0.51	0.55	0.55	0.53	0.47	0.40	0.33	0.26	0.23
C _v	24	375	938	1940	3320	5130	7380	9510	11140	12510
K _v		324	811	1678	2872	4437	6384	8226	9636	10821
F _d		0.090	0.17	0.26	0.34	0.42	0.49	0.57	0.64	0.70
F _L		0.78	0.81	0.81	0.79	0.75	0.69	0.62	0.56	0.52
X _T		0.51	0.55	0.55	0.53	0.47	0.40	0.33	0.26	0.23

Neither Emerson, Emerson Process Management, nor any of their affiliated entities assumes responsibility for the selection, use or maintenance of any product. Responsibility for proper selection, use, and maintenance of any product remains solely with the purchaser and end user.

Fisher, POSI-SEAL, Bettis, FIELDVUE, and ENVIRO-SEAL are marks owned by one of the companies in the Emerson Process Management business unit of Emerson Electric Co. Emerson Process Management, Emerson, and the Emerson logo are trademarks and service marks of Emerson Electric Co. All other marks are the property of their respective owners.

The contents of this publication are presented for informational purposes only, and while every effort has been made to ensure their accuracy, they are not to be construed as warranties or guarantees, express or implied, regarding the products or services described herein or their use or applicability. All sales are governed by our terms and conditions, which are available upon request. We reserve the right to modify or improve the designs or specifications of such products at any time without notice.

Emerson Process Management

Marshalltown, Iowa 50158 USA
Sorocaba, 18087 Brazil
Chatham, Kent ME4 4QZ UK
Dubai, United Arab Emirates
Singapore 128461 Singapore

www.Fisher.com

