



For **Severe Service** Control Solutions, Turn to Fisher Technology and Innovation

AA SPEC 83 VALVE PROVIDES THREE-PHASE FLOW, AVOIDS PLUGGING IN ACIDIC PTA SERVICE

A petrochemical plant in South Carolina manufactures Purified Terephthalic Acid (PTA), a raw material of polyesters and polyamides used in fabric, packaging resin (plastic), and film. During the production process, a highly acidic liquid changes into a mixture composed of liquids, solids, and gases. (The particles or solids that form upstream are the plastic-like end-product.)

The original tank-mounted valve controlled the flow of the acid. Unfortunately, (1) the small-diameter opening between the plug and seat ring, (2) the seat ring extending down into the tank, and (3) the push-down-to-open throttling design led to some plugging problems. Even more unfortunate, the plugged valve resulted in costly process interruptions and stressed other equipment.

Eager to avoid a continued loss of production, plant managers called R. E. Mason, their Fisher Local Business Partner, and requested a modified design. To avoid a costly piping re-design, the new valve had to be an exact fit and delivery was critical. The Fisher Valve Division and its Severe Service group in Marshalltown, Iowa, accepted the design challenge. Meanwhile, technicians at the Fisher Service Company in Columbia, South Carolina, agreed to be responsible for a quick-turnaround assembly.

Fisher-Marshalltown engineers designed a unique valve for this severe-service, three-phase-flow application. They combined elements of two existing designs: the angled body and plug of a Type AA valve and the seat-ring of a Type SS83. The modified design, called an AA Spec 83, moved the plug from inside the tank to inside the valve body; switched from post-guiding to stem-guiding; and modified stem and bonnet dimensions to enable throttling to occur in a flow-to-close design. With a full-port diameter, the new valve enables particles up to 1/2-inch diameter to pass with ease. Plus, the AA Spec 83 valve's stainless steel body and titanium trim make it erosion resistant.

The six-inch valve shipped one week ahead of the requested delivery date and was installed during a scheduled outage. During a later outage, a modification of the stem and packing design was included to reduce solids build-up in the packing area. The added friction of the solids was identified and monitored using the valve's FIELDVUE® DVC6000 Performance Diagnostics (PD) level instrument and AMS ValveLink® software. The customer reports that the valve is operating great and providing good control.

For more severe service solutions, see us at www.fishersevereservice.com.

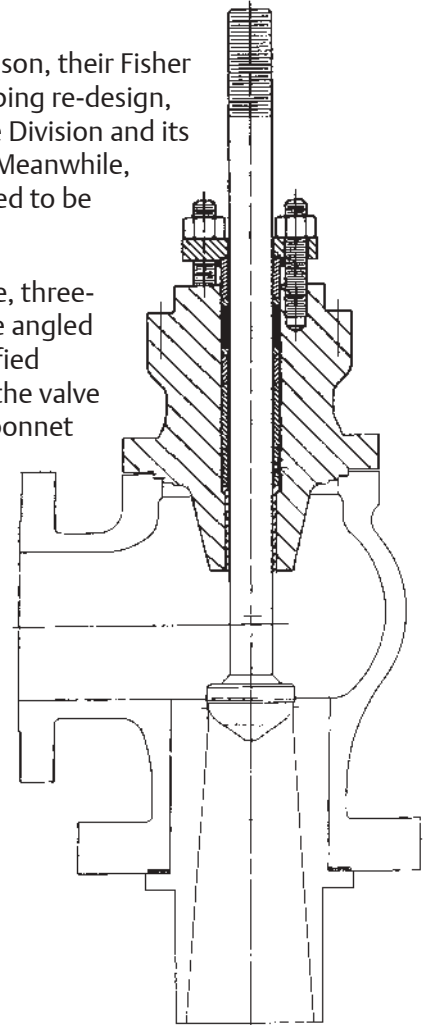

Severe Service



EMERSON
Process Management