

Expansion Transmitter Interface Board Part No. 392951-01-0

For The Following Bristol Instruction Manuals:
CI-3530-20B & CI-3530-25B

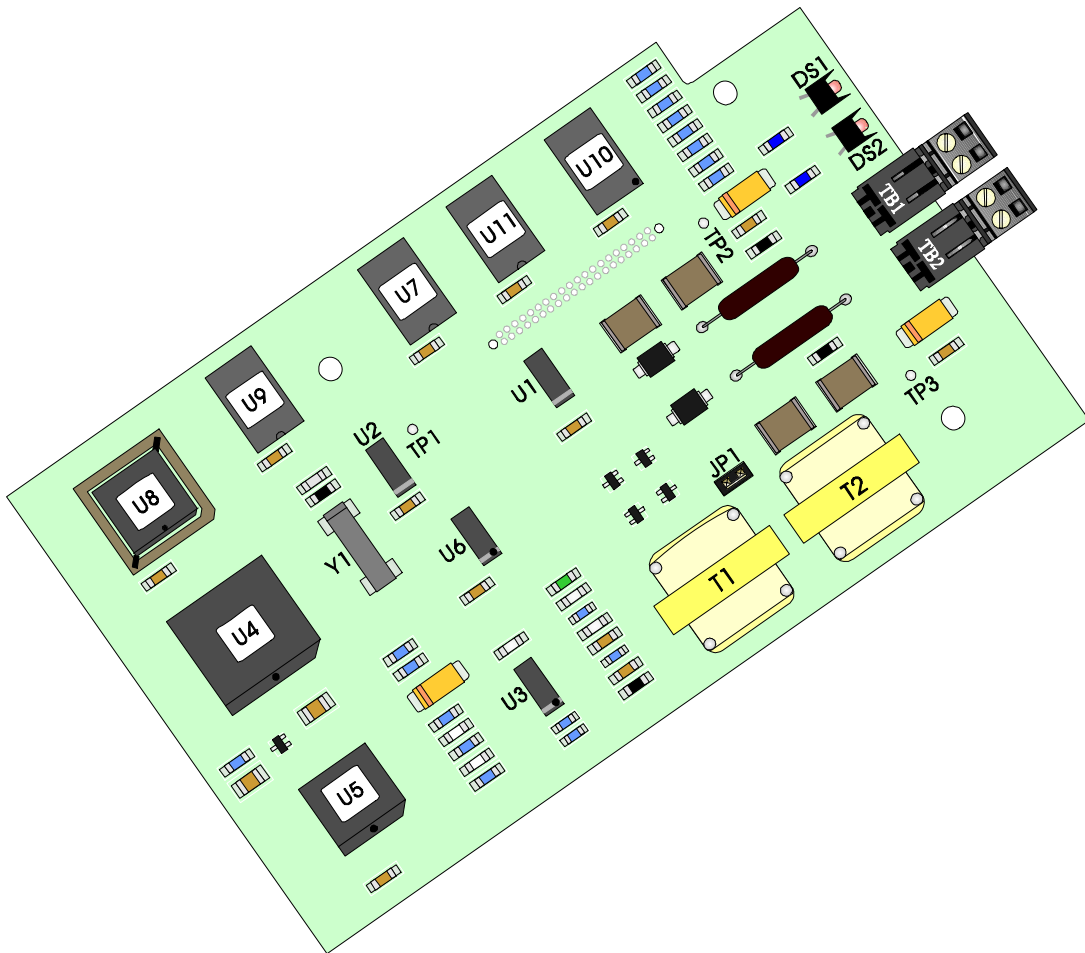

IMPORTANT! READ INSTRUCTIONS BEFORE STARTING!

Be sure that these instructions are carefully read and understood before any operation is attempted. Improper use of this device in some applications may result in damage or injury. The user is urged to keep this book filed in a convenient location for future reference.

These instructions may not cover all details or variations in equipment or cover every possible situation to be met in connection with installation, operation or maintenance. Should problems arise that are not covered sufficiently in the text, the purchaser is advised to contact Bristol for further information.

EQUIPMENT APPLICATION WARNING

The customer should note that a failure of this instrument or system, for whatever reason, may leave an operating process without protection. Depending upon the application, this could result in possible damage to property or injury to persons. It is suggested that the purchaser review the need for additional backup equipment or provide alternate means of protection such as alarm devices, output limiting, fail-safe valves, relief valves, emergency shutoffs, emergency switches, etc. If additional information is required, the purchaser is advised to contact Bristol .

RETURNED EQUIPMENT WARNING

When returning any equipment to Bristol for repairs or evaluation, please note the following: The party sending such materials is responsible to ensure that the materials returned to Bristol are clean to safe levels, as such levels are defined and/or determined by applicable federal, state and/or local law regulations or codes. Such party agrees to indemnify Bristol and save Bristol harmless from any liability or damage which Bristol may incur or suffer due to such party's failure to so act.

ELECTRICAL GROUNDING

Metal enclosures and exposed metal parts of electrical instruments must be grounded in accordance with OSHA rules and regulations pertaining to "Design Safety Standards for Electrical Systems," 29 CFR, Part 1910, Subpart S, dated: April 16, 1981 (OSHA rulings are in agreement with the National Electrical Code).

The grounding requirement is also applicable to mechanical or pneumatic instruments that include electrically-operated devices such as lights, switches, relays, alarms, or chart drives.

EQUIPMENT DAMAGE FROM ELECTROSTATIC DISCHARGE VOLTAGE

This product contains sensitive electronic components that can be damaged by exposure to an electrostatic discharge (ESD) voltage. Depending on the magnitude and duration of the ESD, this can result in erratic operation or complete failure of the equipment. Read supplemental document S14006 at the back of this manual for proper care and handling of ESD-sensitive components.

WARRANTY

- A. Bristol warrants that goods described herein and manufactured by Bristol are free from defects in material and workmanship for one year from the date of shipment unless otherwise agreed to by Bristol in writing.
- B. Bristol warrants that goods repaired by it pursuant to the warranty are free from defects in material and workmanship for a period to the end of the original warranty or ninety (90) days from the date of delivery of repaired goods, whichever is longer.
- C. Warranties on goods sold by, but not manufactured by Bristol, are expressly limited to the terms of the warranties given by the manufacturer of such goods.
- D. All warranties are terminated in the event that the goods or systems or any part thereof are (i) misused, abused or otherwise damaged, (ii) repaired, altered or modified without Bristol's consent, (iii) not installed, maintained and operated in strict compliance with instructions furnished by Bristol, or (iv) worn, injured or damaged from abnormal or abusive use in service time.
- E. THESE WARRANTIES ARE EXPRESSLY IN LIEU OF ALL OTHER WARRANTIES EXPRESS OR IMPLIED (INCLUDING WITHOUT LIMITATION WARRANTIES AS TO MERCHANTABILITY AND FITNESS FOR A PARTICULAR PURPOSE), AND NO WARRANTIES, EXPRESS OR IMPLIED, NOR ANY REPRESENTATIONS, PROMISES, OR STATEMENTS HAVE BEEN MADE BY BRISTOL UNLESS ENDORSED HEREIN IN WRITING. FURTHER, THERE ARE NO WARRANTIES WHICH EXTEND BEYOND THE DESCRIPTION OF THE FACE HEREOF.
- F. No agent of Bristol is authorized to assume any liability for it or to make any written or oral warranties beyond those set forth herein.

REMEDIES

- A. Buyer's sole remedy for breach of any warranty is limited exclusively to repair or replacement without cost to Buyer of any goods or parts found by Seller to be defective if Buyer notifies Bristol in writing of the alleged defect within ten (10) days of discovery of the alleged defect and within the warranty period stated above, and if the Buyer returns such goods to Bristol's Watertown office, unless Bristol's Watertown office designates a different location, transportation prepaid, within thirty (30) days of the sending of such notification and which upon examination by Bristol proves to be defective in material and workmanship. Bristol is not responsible for any costs of removal, dismantling or reinstallation of allegedly defective or defective goods. If a Buyer does not wish to ship the product back to Bristol, the Buyer can arrange to have a Bristol service person come to the site. The Service person's transportation time and expenses will be for the account of the Buyer. However, labor for warranty work during normal working hours is not chargeable.
- B. Under no circumstances will Bristol be liable for incidental or consequential damages resulting from breach of any agreement relating to items included in this quotation, from use of the information herein or from the purchase or use by Buyer, its em-employees or other parties of goods sold under said agreement.

How to return material for Repair or Exchange

Before a product can be returned to Bristol for repair, upgrade, exchange, or to verify proper operation, form (GBU 13.01) must be completed in order to obtain a RA (Return Authorization) number and thus ensure an optimal lead time. Completing the form is very important since the information permits the Bristol Repair Dept. to effectively and efficiently process the repair order.

You can easily obtain a RA number by:

A. FAX

Completing the form (GBU 13.01) and faxing it to (860) 945-3875. A Bristol Repair Dept. representative will return call (or other requested method) with a RA number.

B. E-MAIL

Accessing the form (GBU 13.01) via the Bristol Web site (www.bristolbabcock.com) and sending it via E-Mail to brepair@bristolbabcock.com. A Bristol Repair Dept. representative will return E-Mail (or other requested method) with a RA number.

C. Mail

Mail the form (GBU 13.01) to

Bristol Inc.
Repair Dept.
1100 Buckingham Street
Watertown, CT 06795

A Bristol Repair Dept. representative will return call (or other requested method) with a RA number.

D. Phone

Calling the Bristol Repair Department at (860) 945-2442. A Bristol Repair Department representative will record a RA number on the form and complete Part I, then send the form to the Customer via fax (or other requested method) for Customer completion of Parts II & III.

A copy of the completed Repair Authorization Form with issued RA number should be included with the product being returned. This will allow us to quickly track, repair, and return your product to you.

Bristol

Repair Authorization Form (off-line completion)

(Providing this information will permit Bristol to effectively and efficiently process your return. Completion is required to receive optimal lead time. Lack of information may result in increased lead times.)

Date _____

RA # _____ SH _____

Line No. _____

Standard Repair Practice is as follows: Variations to this is practice may be requested in the "Special Requests" section.

- Evaluate / Test / Verify Discrepancy
- Repair / Replace / etc. in accordance with this form
- Return to Customer

Please be aware of the Non warranty standard charge:

- There is a \$100 minimum evaluation charge, which is applied to the repair if applicable (✓ in "returned" B,C, or D of part III below)

Part I Please complete the following information for single unit or multiple unit returns

Address No. _____ (office use only) Address No. _____ (office use only)

Bill to : _____ Ship to: _____

Purchase Order: _____ Contact Name: _____

Phone: _____ Fax: _____ E-Mail: _____

Part II Please complete Parts II & III for each unit returned

Model No./Part No. _____ Description _____

Range/Calibration _____ S/N _____

Reason for return: Failure Upgrade Verify Operation Other _____

1. Describe the conditions of the failure (Frequency/Intermittent, Physical Damage, Environmental Conditions, Communication, CPU watchdog, etc.)

(Attach a separate sheet if necessary)

2. Comm. interface used: Standalone RS-485 Ethernet Modem (PLM (2W or 4W) or SNW) Other: _____

3. What is the **Firmware** revision? _____ What is the **Software** & version? _____

Part III If checking "replaced" for any question below, check an alternate option if replacement is not available

A. If product is within the warranty time period but is excluded due to Bristol's warranty clause, would you like the product: repaired returned replaced scrapped?

B. If product were found to exceed the warranty period, would you like the product: repaired returned replaced scrapped?

C. If product is deemed not repairable would you like your product: returned replaced scrapped?

D. If Bristol is unable to verify the discrepancy, would you like the product: returned replaced *see below?

* Continue investigating by contacting the customer to learn more about the problem experienced? The person to contact that has the most knowledge of the problem is: _____ phone _____

If we are unable to contact this person the backup person is: _____ phone _____

Special Requests: _____

Ship prepaid to: Bristol Inc., Repair Dept., 1100 Buckingham Street, Watertown, CT 06795

Phone: 860-945-2442 Fax: 860-945-2220

Form GBU 13.01 Rev. C 04/27/06

Bristol *Training*

GET THE MOST FROM YOUR BRISTOL BABCOCK INSTRUMENT OR SYSTEM

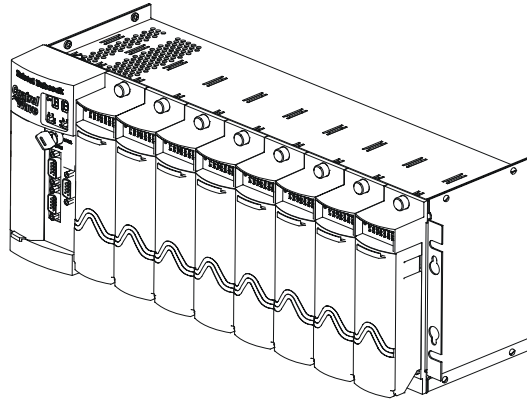

- Avoid Delays and problems in getting your system on-line
- Minimize installation, start-up and maintenance costs.
- Make the most effective use of our hardware and software.
- Know your system.

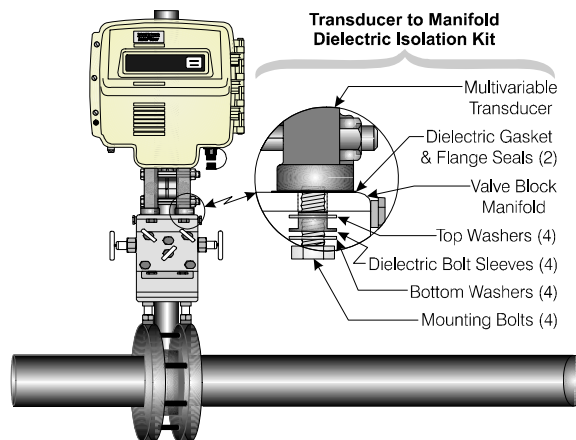

As you know, a well-trained staff is essential to your operation. Bristol Inc. offers a full schedule of classes conducted by full-time, professional instructors. Classes are offered throughout the year at three locations: Houston, Orlando and our Watertown, CT headquarters. By participating in our training, your personnel can learn how to install, calibrate, configure, program and maintain any and all Bristol products and realize the full potential of your system.

For information or to enroll in any class, contact our training department in Watertown at (860) 945-2343. For Houston classes, you can also contact our Houston office, at (713) 685-6200.

A Few Words About Bristol Inc.

For over 100 years, Bristol® has been providing innovative solutions for the measurement and control industry. Our product lines range from simple analog chart recorders, to sophisticated digital remote process controllers and flow computers, all the way to turnkey SCADA systems. Over the years, we have become a leading supplier to the electronic gas measurement, water purification, and wastewater treatment industries.

On off-shore oil platforms, on natural gas pipelines, and maybe even at your local water company, there are Bristol Inc. instruments, controllers, and systems running year-in and year-out to provide accurate and timely data to our customers.

Getting Additional Information

In addition to the information contained in this manual, you may receive additional assistance in using this product from the following sources:

Help Files / Release Notes

Many Bristol software products incorporate help screens. In addition, the software typically includes a 'read me' release notes file detailing new features in the product, as well as other information which was available too late for inclusion in the manual.

Contacting Bristol Inc. Directly

Bristol's world headquarters is located at 1100 Buckingham Street, Watertown, Connecticut 06795, U.S.A.

Our main phone numbers are:

(860) 945-2200
(860) 945-2213 (FAX)

Regular office hours are Monday through Friday, 8:00AM to 4:30PM Eastern Time, excluding holidays and scheduled factory shutdowns. During other hours, callers may leave messages using Bristol's voice mail system.

Telephone Support - Technical Questions

During regular business hours, Bristol's Application Support Group can provide telephone support for your technical questions.

For technical questions about TeleFlow products call (860) 945-8604.

For technical questions about **ControlWave** call (860) 945-2394 or (860) 945-2286.

For technical questions regarding Bristol's **OpenEnterprise** product, call (860) 945-3865 or e-mail: scada@bristolbabcock.com

For technical questions regarding **ACCOL** products, **OpenBSI Utilities**, **UOI** and all other software except for **ControlWave** and **OpenEnterprise** products, call (860) 945-2286.

For technical questions about **Network 3000** hardware, call (860) 945-2502.

You can e-mail the Application Support Group at: **bsupport@bristolbabcock.com**

The Application Support Group maintains an area on our web site for software updates and technical information. Go to: **www.bristolbabcock.com/services/techsupport/**

For assistance in interfacing Bristol hardware to radios, contact Bristol's **Communication Technology Group** in Orlando, FL at **(407) 629-9463** or **(407) 629-9464**.

You can e-mail the Communication Technology Group at:
orlandoRFgroup@bristolbabcock.com

Telephone Support - Non-Technical Questions, Product Orders, etc.

Questions of a non-technical nature (product orders, literature requests, price and delivery information, etc.) should be directed to the nearest sales office (listed on the rear cover of this manual) or to your Bristol-authorized sales representative.

Please call the main Bristol Inc. number (860-945-2200) if you are unsure which office covers your particular area.

Visit our Site on the World Wide Web

For general information about Bristol Inc. and its products, please visit our site on the World Wide Web at: **www.bristolbabcock.com**

Training Courses

Bristol's Training Department offers a wide variety of courses in Bristol hardware and software at our Watertown, Connecticut headquarters, and at selected Bristol regional offices, throughout the year. Contact our Training Department at **(860) 945-2343** for course information, enrollment, pricing, and scheduling.

PIP-EXPTIBS
EXPANSION TRANSMITTER INTERFACE BOARD
PT. Number 392951-01-0

Product Information Package

TABLE OF CONTENTS

<i>SECTION</i>	<i>TITLE</i>	<i>PAGE #</i>
Section 1 - INTRODUCTION		
1.1	DESCRIPTION.....	1
1.1.1	Transmitter Operation.....	1
1.2	LED INDICATORS.....	2
1.3	JUMPER JP1	2
Section 2 – INSTALLATION & SERVICE		
2.1	REMOVAL/REPLACEMENT & INSTALLATION OF THE ETIB.....	3
2.1.1	Removal/Replacement of the Expansion Transmitter Interface Board	3
2.1.2	Installation of the Expansion Transmitter Interface Board Option	6
2.2	FIELD WIRING	7
2.2.1	Terminal Connections.....	7
Section 3 - SPECIFICATIONS		
3.1	GENERAL SPECIFICATION.....	9
3.2	ENVIRONMENTAL SPECIFICATIONS	9
SUPPLEMENTS		
	Special Instructions for Class I, Division 2 Hazardous Locations	Appendix A

Section 1

INTRODUCTION

1.1 DESCRIPTION

Expansion Transmitter Interface Boards (ETIBs) allow up to two (2) Bristol, Series 3508C Transmitters to communicate with an ACCOL loaded host TeleFlow Plus Electronic Gas Measurement Computer (EGMC) (3530-20B) or TeleRTU Plus (3530-25B). The EGMC/RTU polls and stores data from each transmitter and communicates with the network. Two LEDs on the ETIB Board [CD (DS1) & RTS (DS2)] indicate the communication status.

The ETIB Board is housed in either the standard TeleFlow Plus or TeleRTU Plus enclosure and is interfaced to a TeleFlow/TeleRTU CPU Board via the CPU Board's Expansion Connector. Power from and communication with the host CPU Board is supplied through the Expansion Connector. ETIB Boards contain one jumper (JP1) for configuration purposes.

1.1.1 Transmitter Operation

Each Transmitter must be assigned a unique address via the SMARTKIT program as described in Section 4.2 PROGRAM LOADING AND STARTUP of the appropriate 3508 Transmitter manual. Additionally, all Transmitters wired to the TI Board must be operated in the minimum current mode (3.8 mA). This mode is selected via the SMARTKIT program as described in Section 4.7 TRANSMITTER OPERATING MODES of the appropriate 3508 Transmitter manual, i.e., CI-3508-10C, CI-3508-30C or CI-3508-99C.

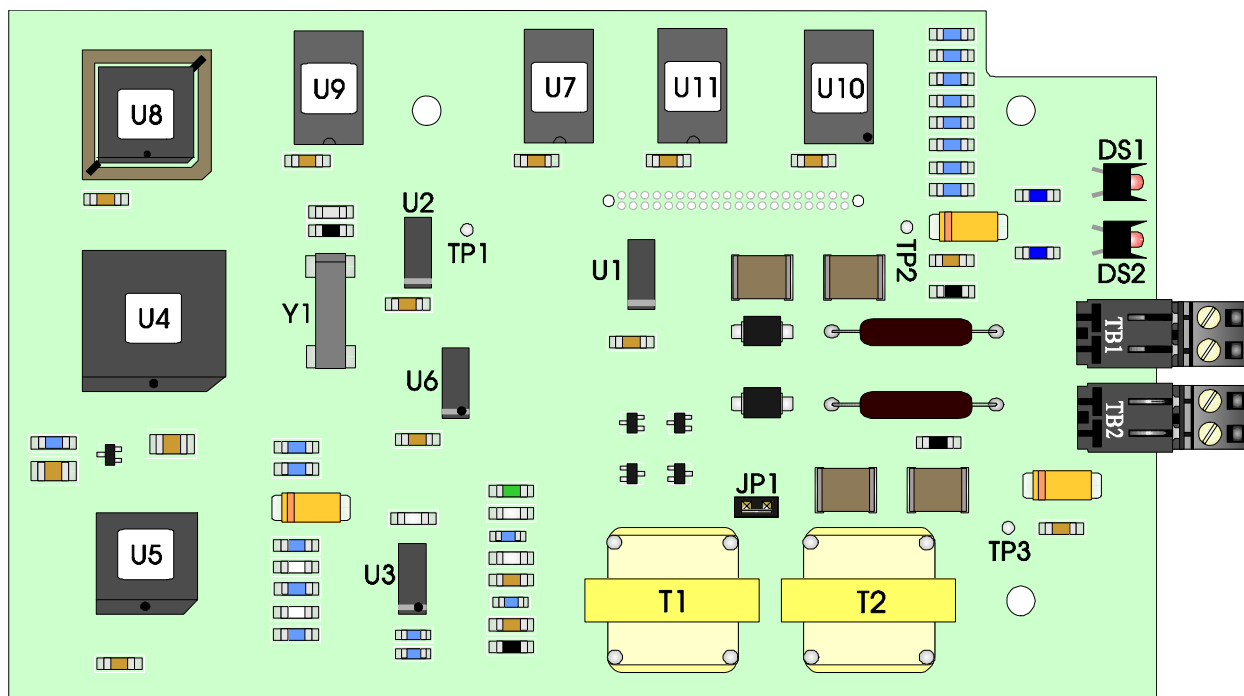

Figure 1 - Transmitter Interface Board P/N 392951-01-0

1.2 LED INDICATORS

The ETIB contains two LEDs which have the following functions: Carrier Detect (CD) and Request to Send (RTS). When the board is sending a Request To Send, LED DS2 (RTS) will be ON and LED DS1 (CD) will be OFF. Conversely, when the ETIB is receiving data from a 3508 Transmitter, LED DS2 (RTS) will be OFF and LED DS1 - Carrier Detect (CD) will be ON.

1.3 JUMPER JP1

Jumper JP1 is used to configure the ETIB for operation with one or two 3508 Transmitters. If only one 3508 Transmitter is to be connected to the ETIB, Jumper JP1 must be installed across JP1-1 and JP1-2. Additionally, when only one 3508 Transmitter is to be connected to the ETIB, it must be connected to connector TB1. When two 3508 Transmitters are connected to the ETIB, Jumper JP1 must be removed and stored in either JP1-1 or JP1-2.

Section 2

INSTALLATION & SERVICE

2.1 REMOVAL/REPLACEMENT & INSTALLATION OF THE ETIB

2.1.1 Removal/Replacement of the Expansion Transmitter Interface Bd.

An installed ETIB option will contain the following parts:

1. Expansion Transmitter Interface Board (ETIB) (with removable Terminal Blocks)
2. Three #8-32 x 1/4" SEM Screws
3. Three #4-40 x 15/32" Standoffs

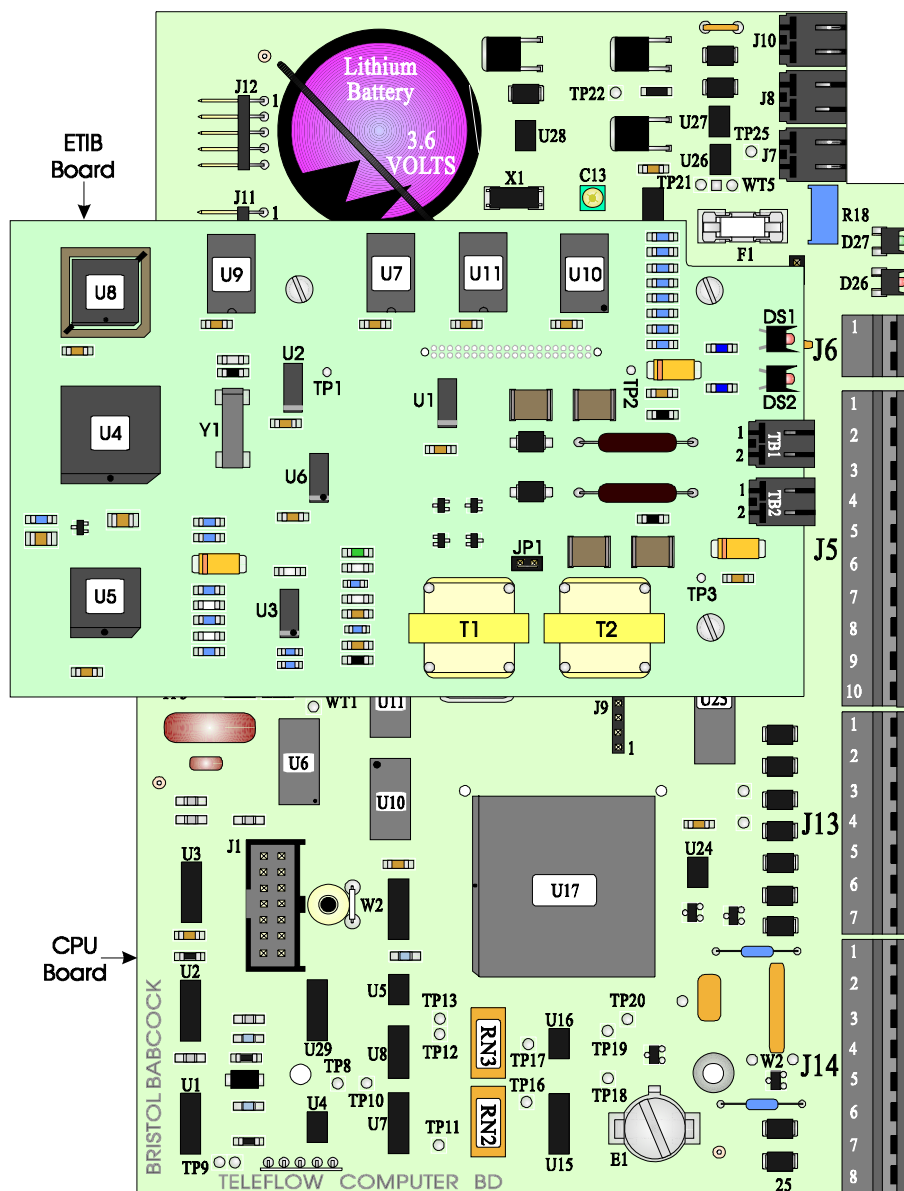

Figure 2 - Expansion Transmitter Interface Bd. Mounted on TeleFlow CPU Board

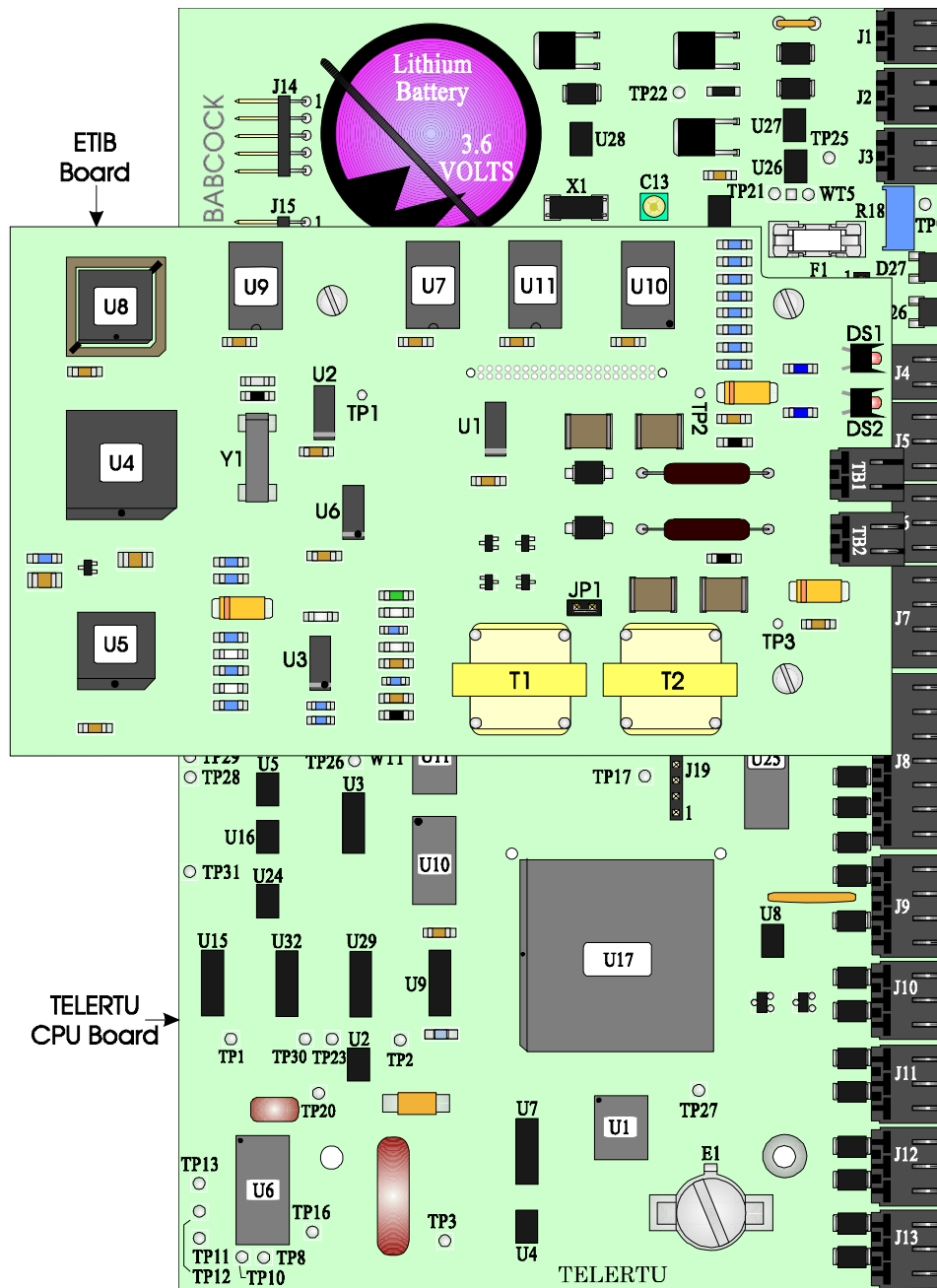

Figure 3 - Expansion TIB Mounted on TeleRTU CPU Board

To remove the optional Expansion Transmitter Interface Board, follow steps 1 through 7 below. To replace the ETIB Board follow steps 2 and 6 below in reverse order, installing rather than removing the item in question and then perform step 7 (see Figures 4 & 5).

Note:

Any PC Board is not to be removed under any circumstances unless the TeleFlow/TeleRTU has been moved to an ESD safe area (see ESDS Manual S14006). The CPU Board should typically only be removed to replace the on board Lithium Battery or Fuse F1 or to install an optional I/O Expansion Board or an Expansion TIB Board.

1. Open the Instrument Front Cover (Door).
2. Disconnect power by removing harness connector plug (P8 for TeleFlow - P2 for TeleRTU) from the CPU Board edge connector (J8 for TeleFlow - J2 for TeleRTU).
3. Unplug the remaining removable Terminal Blocks (with wiring harnesses installed) from the CPU Board's front edge connectors.
4. Unplug the removable Terminal Blocks (with wiring harnesses installed) from the optional ETIB Board.

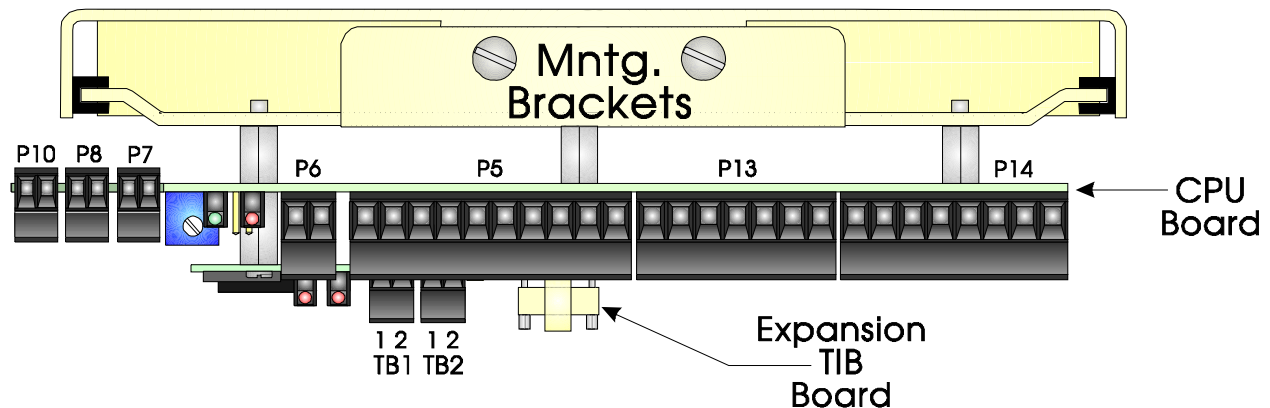

Figure 4 - Horizontally Mounted TeleFlow CPU & Expansion ETIB

5. Remove the two screws that secure the CPU Board's Sliding Mounting Bracket to the Fixed Bracket on the bottom of the Battery Bracket. Carefully slide the CPU Board (and optional ETIB Board) toward the front of the unit and remove harness connections from the Front Panel Switch (J12 on TeleFlow CPU - J14 on TeleRTU CPU), the Display Module (J2 on TeleFlow CPU - J17 on TeleRTU CPU), the Wakeup Switch (J3 on TeleFlow CPU - J16 on TeleRTU CPU), and for TeleFlow CPU Boards connector J1 associated with the Multivariable Transducer.

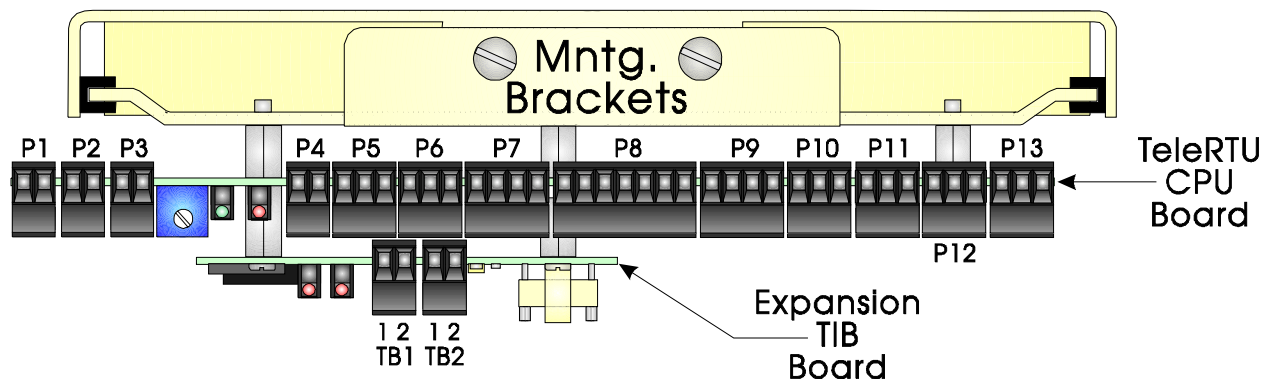

Figure 5 - Horizontally Mounted TeleRTU CPU & Expansion ETIB

6. Remove the 3 screws that secure the ETIB Board to the standoffs and carefully remove the ETIB Board toward the front of the unit.

Note: *If a replacement Expansion Transmitter Interface Board is available follow steps 2 through 6 in reverse order (after configuring Jumper JP1 (see Section 1.3), installing rather than removing the item in question.*

7. Close and Secure the Door.

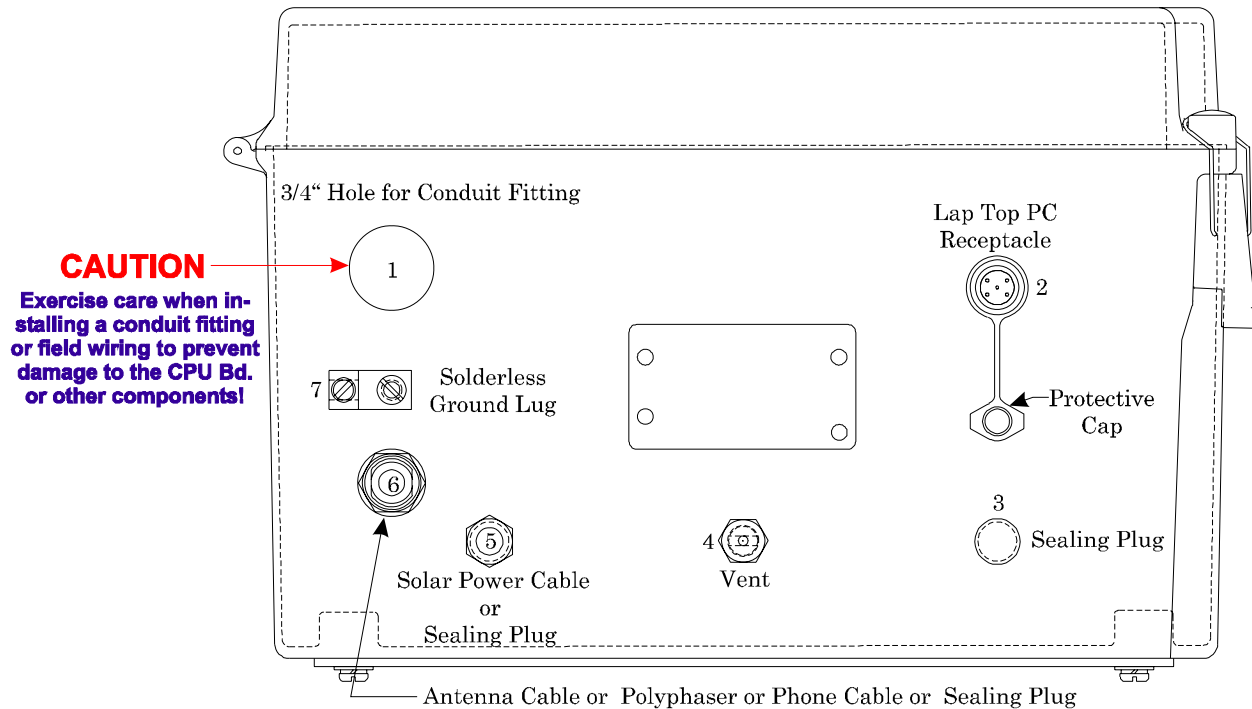

Figure 6 - Bottom View of TeleRTU Plus (Similar to TeleFlow Plus)

2.1.2 Installation of the Expansion Transmitter Interface Board Option

1. Open the Instrument Front Cover and remove the CPU Board (see Section 2.1.1 - steps 2 through 5).
2. Replace the three screws that secure the CPU Board to the Mounting standoffs with #4-40 x 15/32" Standoffs (see Section 2.1.1 - Figures 4 & 5).
3. Install the ETIB Board onto the CPU Board in question making sure that the Expansion Connectors properly mate. Secure the ETIB Board to the three mounting standoffs with three #8-32 x 1/4" screws.
4. Reinstall the CPU Board (with ETIB) into the TeleFlow or TeleRTU (see Section 2.1.1).
5. Install 3508 Transmitter wiring to the ETIB Board (see Section 2.2.1). Wiring should be routed through a 3/4" conduit fitting (user installed) on the bottom of the enclosure (see Figure 6).
6. Close and Secure the Instrument Front Cover.

2.2 FIELD WIRING

The device uses compression-type terminals that accommodate up to #14 AWG wire. A connection is made by inserting the bared end (1/4 inch Max.) into the clamp beneath the screw and then securing the screw. Insert the bared end fully to prevent short circuits.

Allow some slack in the wires when making terminal connections. The slack makes the connections more manageable and minimizes mechanical strain on the printed circuit boards and harnesses.

2.2.1 Terminal Connections

ETIB Boards contain two terminal blocks that field wiring connections to the transmitter(s). TB1 & TB2 are two-position Terminal Blocks which connect to the signal/power inputs of the transmitters.

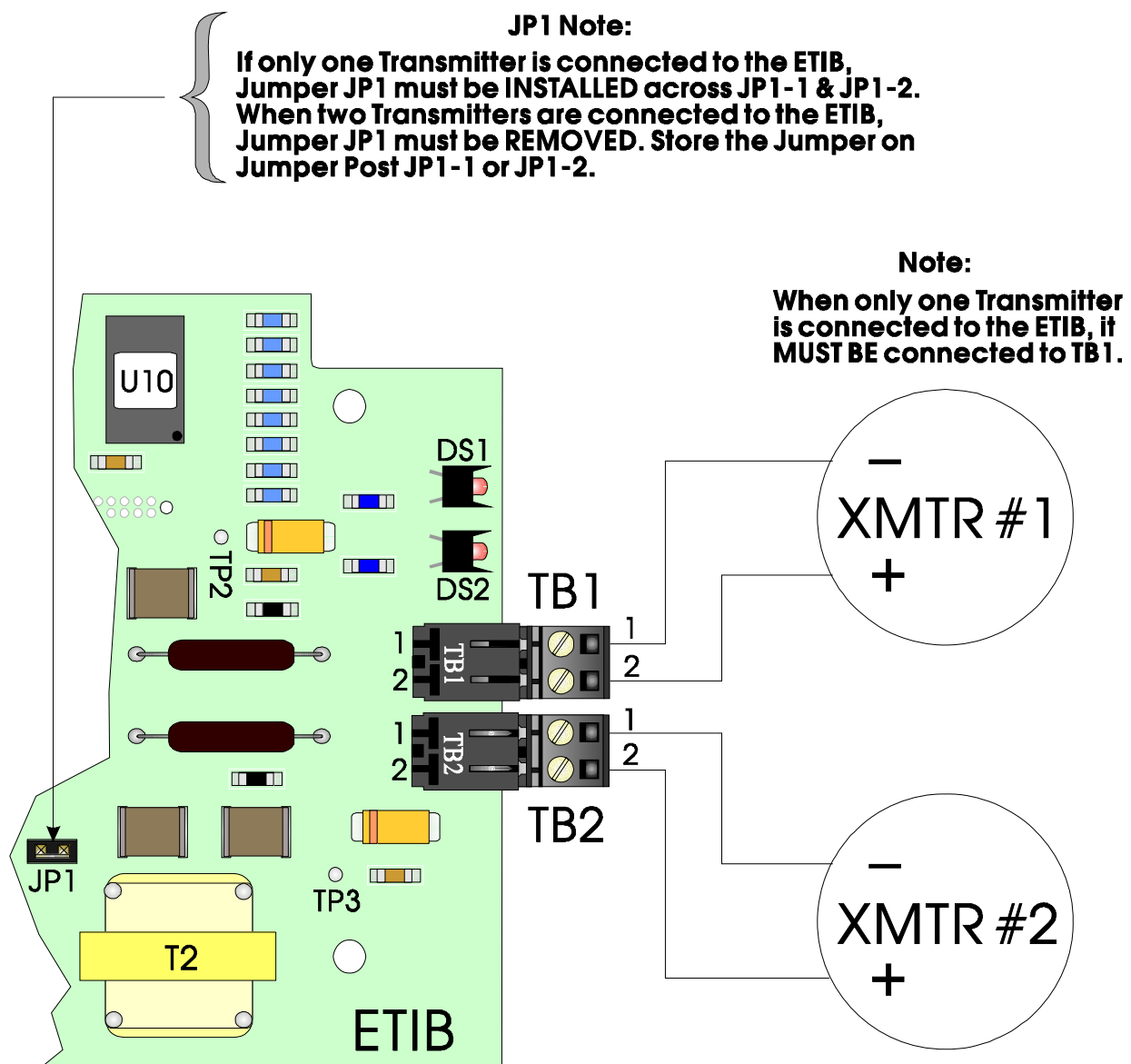

Figure 7 - Internally Powered Transmitter Field Wiring

TABLE 1 - ETIB BOARD TERMINAL DESIGNATIONS

LPTIB TB#	LPTIB TB NAME	CONNECTION if PDB. Is Present	3530-20B CONNECTION If no PDB.	3530-25B CONNECTION If no PDB.
TB1-1	XMTR1-	3508-	3508-	3508-
TB1-2	XMTR1+	3508+	3508+	3508+
TB2-1	XMTR2-	3508-	3508-	3508-
TB2-2	XMTR2+	3508+	3508+	3508+

ETIB Boards may be connected to internally powered transmitters. Connection to internally powered transmitters (powered from ETIB's on-board +12V Supply/Regulator) is illustrated in Figure 7.

Section 3

SPECIFICATIONS

3.1 GENERAL SPECIFICATIONS

Communication Interface:	RS-232 (\pm 3V minimum)
3508-10C/30C Interface:	FSK Modem - Bell 202 Compatible (1200 Hz/2200 Hz modulation)
ESD Susceptibility:	Field connected circuits are designed to meet the requirements of IEC 801-2 for ESD withstand capability up to 10KV.
EMI Compatibility:	Designed to coexist within a shielded enclosure with the TeleFlow (3530-20B) or the TeleRTU (3530-25B) electronics. EMI radiation is insignificant and susceptibility is comparable or superior to associated electronics.
Transient Susceptibility:	Field connected circuits are designed to meet the requirements of ANSI/IEEEC37.90-1998 (Formerly IEEE 472) for surge withstand capability.

3.2 ENVIRONMENTAL SPECIFICATIONS

Operating Temperature:	-40°C to +60°C (-40°F to +140°F)
Storage Temperature:	-40°C to +85°C (-40°F to +185°C)
Relative Humidity:	15% - 95% Non-condensing
Vibration:	1G for 10Hz to 500Hz per SAMA PMC-31-1 (without damage or impairment)

**Expansion Transmitter Interface Board
Special Instructions for Class I, Division 2 Hazardous Locations**

1. The Bristol Expansion Transmitter Interface Board (ETIB) is listed by Underwriters Laboratories (UL) as nonincendive and is suitable for use in Class I, Division 2, Groups A, B, C and D hazardous locations or non-hazardous locations only. Read this document carefully before installing a nonincendive Bristol ETIB Board. In the event of a conflict between the ETIB Board User Manual (PIP-EXPTIBS) and this document, always follow the instructions in this document.
2. Wiring must be performed in accordance with Class I, Division 2 wiring methods as defined in Article 501-4 (b) of the National Electrical Code, NFPA 70 for installations within the United States, or as specified in Section 18-152 of the Canadian Electrical Code for installation in Canada.
3. **WARNING: EXPLOSION HAZARD - Substitution of components may impair suitability for use in Class I, Division 2 environments.**
4. **WARNING: EXPLOSION HAZARD - When situated in a hazardous location, turnoff power before servicing/replacing the unit and before installing or removing I/O wiring.**
5. **WARNING: EXPLOSION HAZARD - Do Not disconnect equipment unless the power has been switched off or the area is known to be nonhazardous.**

Expansion Transmitter Interface Board Part No. 392951-01-0

**Emerson Process Management
Bristol, Inc.**

1100 Buckingham Street
Watertown, CT 06795
Phone: +1 (860) 945-2262
Fax: +1 (860) 945-2525
www.EmersonProcess.com/Bristol

**Emerson Electric Canada, Ltd.
Bristol Canada**

6338 Viscount Rd.
Mississauga, Ont. L4V 1H3
Canada
Phone: 905-362-0880
Fax: 905-362-0882
www.EmersonProcess.com/Bristol

**Emerson Process Management
BBI, S.A. de C.V.**

Homero No. 1343, 3er Piso
Col. Morales Polanco
11540 Mexico, D.F.
Mexico
Phone: (52-55)-52-81-81-12
Fax: (52-55)-52-81-81-09
www.EmersonProcess.com/Bristol

**Emerson Process Management
Bristol Babcock, Ltd.**

Blackpole Road
Worcester, WR3 8YB
United Kingdom
Phone: +44 1905 856950
Fax: +44 1905 856969
www.EmersonProcess.com/Bristol

**Emerson Process Management
Bristol, Inc.**

22 Portofino Crescent,
Grand Canals Bunbury, Western Australia 6230
Mail to: PO Box 1987 (zip 6231)
Phone: +61 (8) 9725-2355
Fax: +61 (8) 8 9725-2955
www.EmersonProcess.com/Bristol

The information in this document is subject to change without notice. Every effort has been made to supply complete and accurate information. However, Bristol, Inc. assumes no responsibility for any errors that may appear in this document.

If you have comments or questions regarding this manual, please direct them to your local Bristol sales representative, or direct them to one of the addresses listed at left.

Bristol, Inc. does not guarantee the accuracy, sufficiency or suitability of the software delivered herewith. The Customer shall inspect and test such software and other materials to his/her satisfaction before using them with important data.

There are no warranties, expressed or implied, including those of merchantability and fitness for a particular purpose, concerning the software and other materials delivered herewith.

TeleFlow™ is a trademark of Bristol, Inc. The Emerson logo is a trade mark and service mark of Emerson Electric Co. Other trademarks or copyrighted products mentioned in this document are for information only, and belong to their respective companies, or trademark holders.

Copyright (c) 2007, Bristol, Inc., 1100 Buckingham St., Watertown, CT 06795. No part of this manual may be reproduced in any form without the express written permission of Bristol, Inc.

This page provides links that allow you to go to a specific manual's Table of Content (T.O.C.), return to document PIP-EXPTIBS' Table of Content or return to the first page of the Main Menu. Links are provided by selecting the appropriate Link Text Box.

**Select the
Appropriate
Link Text Box**



Go to CI-3530-20B T.O.C.

Go to CI-3530-25B T.O.C.

Go to CI-3808 T.O.C.

Return to PIP-EXPTIBS T.O.C.

Return to the Main Menu