

HIGHWAY ADDRESSABLE REMOTE TRANSDUCER

(HART®)

DEVICE INTERFACE

Part No. 392930-01-3

(For Models 33XX)

For The Following BBI Instruction Manuals:
CI-3305, CI-3310, CI-3330 & CI3335

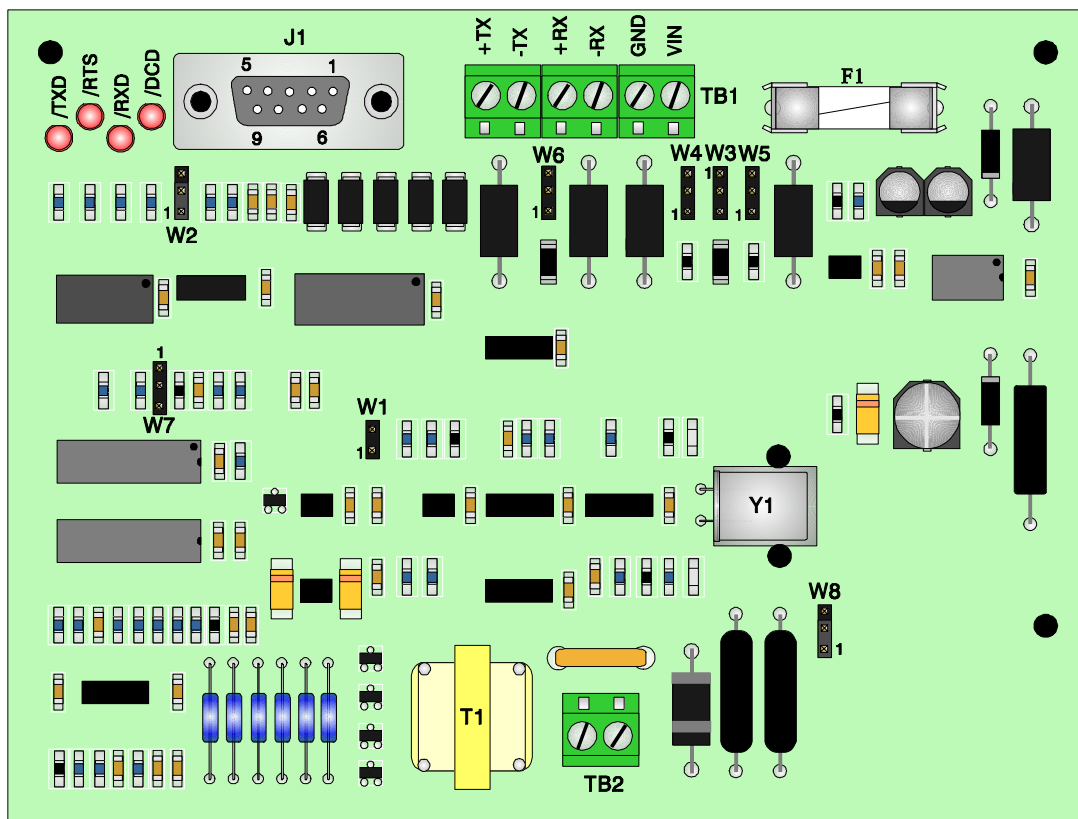

Bristol Babcock

NOTICE
Copyright Notice

The information in this document is subject to change without notice. Every effort has been made to supply complete and accurate information. However, Bristol Babcock assumes no responsibility for any errors that may appear in this document.

Request for Additional Instructions

Additional copies of instruction manuals may be ordered from the address below per attention of the Sales Order Processing Department. List the instruction book numbers or give complete model number, serial or software version number. Furnish a return address that includes the name of the person who will receive the material. Billing for extra copies will be according to current pricing schedules.

HART® is a registered trademark of the HART Communication Foundation, Austin, Texas USA. ACCOL™ is a trademark of Bristol Babcock. Other trademarks or copyrighted products mentioned in this document are for information only, and belong to their respective companies, or trademark holders.

Copyright (c) 2003, Bristol Babcock, 1100 Buckingham St., Watertown, CT 06795. No part of this manual may be reproduced in any form without the express written permission of Bristol Babcock.

IMPORTANT! READ INSTRUCTIONS BEFORE STARTING!

Be sure that these instructions are carefully read and understood before any operation is attempted. Improper use of this device in some applications may result in damage or injury. The user is urged to keep this book filed in a convenient location for future reference.

These instructions may not cover all details or variations in equipment or cover every possible situation to be met in connection with installation, operation or maintenance. Should problems arise that are not covered sufficiently in the text, the purchaser is advised to contact Bristol Babcock for further information.

EQUIPMENT APPLICATION WARNING

The customer should note that a failure of this instrument or system, for whatever reason, may leave an operating process without protection. Depending upon the application, this could result in possible damage to property or injury to persons. It is suggested that the purchaser review the need for additional backup equipment or provide alternate means of protection such as alarm devices, output limiting, fail-safe valves, relief valves, emergency shutoffs, emergency switches, etc. If additional information is required, the purchaser is advised to contact Bristol Babcock.

RETURNED EQUIPMENT WARNING

When returning any equipment to Bristol Babcock for repairs or evaluation, please note the following: The party sending such materials is responsible to ensure that the materials returned to Bristol Babcock are clean to safe levels, as such levels are defined and/or determined by applicable federal, state and/or local law regulations or codes. Such party agrees to indemnify Bristol Babcock and save Bristol Babcock harmless from any liability or damage which Bristol Babcock may incur or suffer due to such party's failure to so act.

ELECTRICAL GROUNDING

Metal enclosures and exposed metal parts of electrical instruments must be grounded in accordance with OSHA rules and regulations pertaining to "Design Safety Standards for Electrical Systems," 29 CFR, Part 1910, Subpart S, dated: April 16, 1981 (OSHA rulings are in agreement with the National Electrical Code).

The grounding requirement is also applicable to mechanical or pneumatic instruments that include electrically-operated devices such as lights, switches, relays, alarms, or chart drives.

EQUIPMENT DAMAGE FROM ELECTROSTATIC DISCHARGE VOLTAGE

This product contains sensitive electronic components that can be damaged by exposure to an electrostatic discharge (ESD) voltage. Depending on the magnitude and duration of the ESD, this can result in erratic operation or complete failure of the equipment. Read BBI supplemental document S14006 for proper care and handling of ESD-sensitive components.

Bristol Babcock 1100 Buckingham Street, Watertown, CT 06795
Telephone (860) 945-2200

WARRANTY

- A. Bristol warrants that goods described herein and manufactured by Bristol are free from defects in material and workmanship for one year from the date of shipment unless otherwise agreed to by Bristol in writing.
- B. Bristol warrants that goods repaired by it pursuant to the warranty are free from defects in material and workmanship for a period to the end of the original warranty or ninety (90) days from the date of delivery of repaired goods, whichever is longer.
- C. Warranties on goods sold by, but not manufactured by Bristol are expressly limited to the terms of the warranties given by the manufacturer of such goods.
- D. All warranties are terminated in the event that the goods or systems or any part thereof are (i) misused, abused or otherwise damaged, (ii) repaired, altered or modified without Bristol's consent, (iii) not installed, maintained and operated in strict compliance with instructions furnished by Bristol, or (iv) worn, injured or damaged from abnormal or abusive use in service time.
- E. THESE WARRANTIES ARE EXPRESSLY IN LIEU OF ALL OTHER WARRANTIES EXPRESS OR IMPLIED (INCLUDING WITHOUT LIMITATION WARRANTIES AS TO MERCHANTABILITY AND FITNESS FOR A PARTICULAR PURPOSE), AND NO WARRANTIES, EXPRESS OR IMPLIED, NOR ANY REPRESENTATIONS, PROMISES, OR STATEMENTS HAVE BEEN MADE BY BRISTOL UNLESS ENDORSED HEREIN IN WRITING. FURTHER, THERE ARE NO WARRANTIES WHICH EXTEND BEYOND THE DESCRIPTION OF THE FACE HEREOF.
- F. No agent of Bristol is authorized to assume any liability for it or to make any written or oral warranties beyond those set forth herein.

REMEDIES

- A. Buyer's sole remedy for breach of any warranty is limited exclusively to repair or replacement without cost to Buyer of any goods or parts found by Seller to be defective if Buyer notifies Bristol in writing of the alleged defect within ten (10) days of discovery of the alleged defect and within the warranty period stated above, and if the Buyer returns such goods to Bristol's Watertown office, unless Bristol's Watertown office designates a different location, transportation prepaid, within thirty (30) days of the sending of such notification and which upon examination by Bristol proves to be defective in material and workmanship. Bristol is not responsible for any costs of removal, dismantling or reinstallation of allegedly defective or defective goods. If a Buyer does not wish to ship the product back to Bristol, the Buyer can arrange to have a Bristol service person come to the site. The Service person's transportation time and expenses will be for the account of the Buyer. However, labor for warranty work during normal working hours is not chargeable.
- B. Under no circumstances will Bristol be liable for incidental or consequential damages resulting from breach of any agreement relating to items included in this quotation from use of the information herein or from the purchase or use by Buyer, its employees or other parties of goods sold under said agreement.

How to return material for Repair or Exchange

Before a product can be returned to Bristol Babcock for repair, upgrade, exchange, or to verify proper operation, form (GBU 13.01) must be completed in order to obtain a RA (Return Authorization) number and thus ensure an optimal lead time. Completing the form is very important since the information permits the Bristol Babcock Repair Dept. to effectively and efficiently process the repair order.

You can easily obtain a RA number by:

A. FAX

Completing the form (GBU 13.01) and faxing it to (860) 945-3875. A BBI Repair Dept. representative will return call (or other requested method) with a RA number.

B. E-MAIL

Accessing the form (GBU 13.01) via the Bristol Babcock Web site (www.bristolbabcock.com) and sending it via E-Mail to brepair@bristolbabcock.com. A BBI Repair Dept. representative will return E-Mail (or other requested method) with a RA number.

C. Mail

Mail the form (GBU 13.01) to

Bristol Babcock Inc.
Repair Dept.
1100 Buckingham Street
Watertown, CT 06795

A BBI Repair Dept. representative will return call (or other requested method) with a RA number.

D. Phone

Calling the BBI Repair Department at (860) 945-2442. A BBI Repair Department representative will record a RA number on the form and complete Part I, then send the form to the Customer via fax (or other requested method) for Customer completion of Parts II & III.

A copy of the completed Repair Authorization Form with issued RA number should be included with the product being returned. This will allow us to quickly track, repair, and return your product to you.

Bristol Babcock Inc. Repair Authorization Form

(Providing this information will permit BBI to effectively and efficiently process your return. Completion is required to receive optimal lead time. Lack of information may result in increased lead times.)

Date _____ RA # _____ SH _____ Line No. _____

Standard Repair Practice is as follows: Variations to this is practice may be requested in the "Special Requests" section.

- Evaluate / Test / Verify Discrepancy
- Repair / Replace / etc. in accordance with this form
- Return to Customer

Please be aware of the Non warranty standard charge:

- There is a \$100 minimum evaluation charge, which is applied to the repair if applicable (√ in "returned" B,C, or D of part III below)

Part I Please complete the following information for single unit or multiple unit returns

Address No. _____ (office use only) Address No. _____ (office use only)

Bill to : _____ Ship to: _____

Purchase Order: _____ Contact Name: _____

Phone: _____ Fax: _____ E-Mail: _____

Part II Please complete Parts II & III for each unit returned

Model No./Part No. _____ Description _____

Range/Calibration _____ S/N _____

Reason for return : Failure Upgrade Verify Operation Other _____

1. Describe the conditions of the failure (Frequency/Intermittent, Physical Damage, Environmental Conditions, Communication, CPU watchdog, etc.)

(Attach a separate sheet if necessary)

2. Comm. interface used: Standalone RS-485 Ethernet Modem (PLM (2W or 4W) or SNW) Other: _____

3. What is the **Firmware** revision? _____ What is the **Software** & version? _____

Part III If checking "replaced" for any question below, check an alternate option if replacement is not available

A. If product is within the warranty time period but is excluded due to BBI's warranty clause, would you like the product: repaired returned replaced scrapped?

B. If product were found to exceed the warranty period, would you like the product: repaired returned replaced scrapped?

C. If product is deemed not repairable would you like your product: returned replaced scrapped?

D. If BBI is unable to verify the discrepancy, would you like the product: returned replaced *see below?

* Continue investigating by contacting the customer to learn more about the problem experienced? The person to contact that has the most knowledge of the problem is: _____ phone _____

If we are unable to contact this person the backup person is: _____ phone _____

Special Requests: _____

Ship prepaid to: Bristol Babcock Inc., Repair Dept., 1100 Buckingham Street, Watertown, CT 06795
Phone: 860-945-2442 Fax: 860-945-3875

Bristol Babcock *Training*

GET THE MOST FROM YOUR BRISTOL BABCOCK INSTRUMENT OR SYSTEM

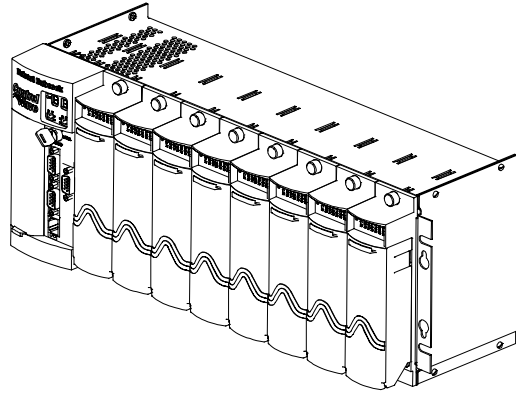

- Avoid Delays and problems in getting your system on-line
- Minimize installation, start-up and maintenance costs.
- Make the most effective use of our hardware and software.
- Know your system.

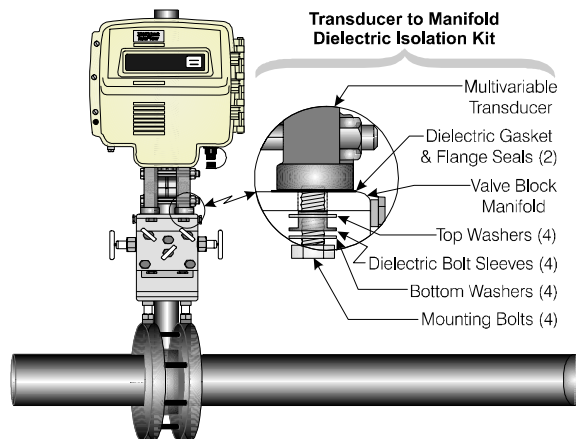

As you know, a well-trained staff is essential to your operation. Bristol Babcock offers a full schedule of classes conducted by full-time, professional instructors. Classes are offered throughout the year at four locations: Houston, Birmingham, Orlando and our Watertown, CT headquarters. By participating in our training, your personnel can learn how to install, calibrate, configure, program and maintain any and all Bristol Babcock products and realize the full potential of your system.

For information or to enroll in any class, contact our training department in Watertown at (860) 945-2269. For Houston classes, you can also contact our Houston office, at (713) 685-6200.

A Few Words About Bristol Babcock

For over 100 years, Bristol[®] has been providing innovative solutions for the measurement and control industry. Our product lines range from simple analog chart recorders, to sophisticated digital remote process controllers and flow computers, all the way to turnkey SCADA systems. Over the years, we have become a leading supplier to the electronic gas measurement, water purification, and wastewater treatment industries.

On off-shore oil platforms, on natural gas pipelines, and maybe even at your local water company, there are Bristol Babcock instruments, controllers, and systems running year-in and year-out to provide accurate and timely data to our customers.

Getting Additional Information

In addition to the information contained in this manual, you may receive additional assistance in using this product from the following sources:

Contacting Bristol Babcock Directly

Bristol Babcock's world headquarters are located at 1100 Buckingham Street, Watertown, Connecticut 06795, U.S.A.

Our main phone numbers are:

(860) 945-2200
(860) 945-2213 (FAX)

Regular office hours are Monday through Friday, 8:00AM to 4:30PM Eastern Time, excluding holidays and scheduled factory shutdowns. During other hours, callers may leave messages using Bristol's voice mail system.

Telephone Support - Technical Questions

During regular business hours, Bristol Babcock's Application Support Group can provide telephone support for your technical questions.

For technical questions about TeleFlow[™] products call (860) 945-8604.

For technical questions about **ControlWave** call (860) 945-2244 or (860) 945-2286.

For technical questions regarding Bristol's **OpenEnterprise** product, call (860) 945-2501 or e-mail: **openenterprise@bristolbabcock.com**

For technical questions regarding **ACCOL** products, **Open BSI Utilities**, as well as Bristol's **Enterprise Server[®]/Enterprise Workstation[®]** products, call (860) 945-2286.

For technical questions about **Network 3000** hardware, call (860) 945-2502.

You can e-mail the Application Support Group at: **bsupport@bristolbabcock.com**

The Application Support Group maintains an area on our web site for software updates and technical information. Go to: **www.bristolbabcock.com/services/techsupport/**

For assistance in interfacing Bristol Babcock hardware to radios, contact Bristol Babcock's **Communication Technology Group** in Orlando, FL at **(407) 629-9463** or **(407) 629-9464**.

Telephone Support - Non-Technical Questions, Product Orders, etc.

Questions of a non-technical nature (product orders, literature requests, price and delivery information, etc.) should be directed to the nearest sales office (listed on the rear cover) or to your Bristol-authorized sales representative. A list of

Please call the main Bristol Babcock number (860-945-2200) if you are unsure which office covers your particular area.

Visit our Site on the World Wide Web

For general information about Bristol Babcock and its products, please visit our site on the World Wide Web at: **www.bristolbabcock.com**

Training Courses

Bristol Babcock's Training Department offers a wide variety of courses in Bristol hardware and software at our Watertown, Connecticut headquarters, and at selected Bristol regional offices, throughout the year. Contact our Training Department at **(860) 945-2269** for course information, enrollment, pricing, and scheduling.

PIP-HART33XX HIGHWAY ADDRESSABLE REMOTE TRANSDUCER (HART[®]) DEVICE INTERFACE

TABLE OF CONTENTS

<i>SECTION</i>	<i>TITLE</i>	<i>PAGE #</i>
Section 1 - INTRODUCTION		
1.1	GENERAL INTRODUCTION.....	1
1.2	FEATURES.....	1
1.3	THEORY	1
1.4	HDI DESCRIPTION	2
1.4.1	HDI Board Connectors.....	2
1.4.2	HDI Board Status LEDs	3
1.4.3	HDI Board Circuitry.....	4
Section 2 - CONFIGURATION & CONNECTIONS		
2.1	RESTRICTIONS & ASSUMPTIONS	7
2.1.1	HART Slave Devices.....	7
2.1.2	3508 Smart Transmitters	7
2.2	CONFIGURAING A SINGLE HDI BOARD	8
2.2.1	RS-485 Interface - To a Single HDI Board.....	8
2.2.2	RS-232 Interface - To a Single HDI Board.....	10
2.2.3	Configuring Multiple HDI Assemblies into a Single 33XX Master	11
2.2.3.1	Multiple HDI Boards Configured for RS-485 Operation	11
2.2.3.2	Multiple HDI Boards Configured for RS-232 Operation	13
Section 3 - SPECIFICATIONS		
3.1	HART COMMUNICATION PROTOCOL PARAMETERS FOR PHYSICAL LINK	15
3.2	HART DEVICE IMPEDANCE SPECIFICATION.....	15
3.3	HART DEVICE POWER SUPPLY REQUIREMENTS	15
3.4	PHASE SHIFT SPECIFICATION.....	15
3.5	PERFORMANCE SPECIFICATION.....	15
3.6	ENVIRONMENTAL SPECIFICATION	16
SUPPLEMENTS		
	Special Instructions for Class I, Division 2 Hazardous Locations.....	Appendix A
REFERENCE DOCUMENTS		
<i>(Note: These documents are not provided in this manual)</i>		
	BBI HART MASTER PROTOCOL MANUAL.....	D4068
	BBI ACCOL II REFERENCE MANUAL	D4044
	HART [®] FSK PHYSICAL LAYER SPECIFICATION - HART [®] Communication Foundation Document Number	HCF_SPEC-54

Section 1

INTRODUCTION

1.1 GENERAL INTRODUCTION

Note: HART® is a registered trademark of the HART® Communication Foundation of Austin, Texas, USA. Any time the term ‘HART’ is used hereafter in this document, the term implies the registered trademark.

Highway Addressable Remote Transducer (HART) Device Interfaces (HDI) allows HART slave devices or BBI 3508 transmitters to communicate with a BBI Series 33XX DPC/RTU, i.e., 3305s, 3310s, 3330s, and 3335s. The HDI supports RS-232 and RS-485 interfaces. The interface to the field devices is composed of a jumper selectable 249 ohm resistor in parallel with an AC coupled transformer. An HART/TIB ACCOL Custom Module and the configuration of a host (33XX) communications port as a custom port in ‘HART mode’ are required to support the protocol (Data Link Layer) for HART devices. The ACCOL Master Module is used to support RS-232 configured HDIs for communication with BBI 3508 transmitters. Each HDI can interface with up to 15 HART slave devices.

1.2 FEATURES

- Selectable RS-232 or RS-485 Interface to DPC/RTU
- Transformer Coupled Comm. Interface to HART devices
- Operates from external 9 to 30 VDC power source
- Usable with both HART slave devices and BBI 3508 transmitters. RS-232/RS-485 mode of communications is valid for HART slave devices. RS-232 mode is valid for BBI 3508s.
- Conforms to HART® FSK Physical Layer Specification.

1.3 THEORY

The BBI HART Device Interface (HDI) provides for master/slave communications, with the master originating each transaction, and slaves only generating replies when prompted by the master. HART allows for 2 ‘masters’ on a single link. The “Primary Master” is the normal control-system master, and when required, a hand-held communicator can be used as the “Secondary Master,” for maintenance purposes. Primary and secondary masters must be configured to use separate addresses.

The BBI HDI board provides an RS-485/232 interface to a BBI 33XX DPC/RTU Communications Port and a two-wire (voltage sourced or current sourced) connection to a ‘HART device’ or to a BBI 3508. Twisted-pair copper cable is used as the medium.

The HART Device Interface operates from 9 to 30 VDC bulk supply. The assembly supports RS-232 or RS-485 interfaces to the host BBI 33XX DPC/RTU. The signals are TXD, RXD, CTS, RTS and CD for RS-232 operations and +TXD, -TXD, +RXD and -RXD for RS-485 operation. Interface to the field device is composed of a jumper selectable 249 ohm resistor in parallel with an AC coupled transformer. FSK signal amplitude during transmission is between 400 to 600 mV with the average value of the FSK signal at 0 V. The HDI board

receiver input requires a signal that must be in the range of 120 mV to 1.5 V (Peak-to-Peak). FSK signals from the field devices below 80 mV (Peak-to-Peak) will be ignored by the interface board.

1.4 HDI DESCRIPTION

The HART Adapter Interface Board is assembled in a DIN Rail Mounting Assembly. This assembly measures 5.56" long by 4.37" in high by 1.06" deep. In addition to 8 selectable jumpers and 4 status LEDs, the HDI Board contains three connectors (see Figures 1 & 10).

1.4.1 HDI Board Connectors

J1 - a 9-Pin D-Type Connector for the RS-232 Interface (see Table 1)

TB1 - a 6-Point Term. Block for the RS-485 Interface and the Input Power (see Table 2)

TB2 - a 2-Point Terminal Block for Slave Device Field Connections (see Table 3)

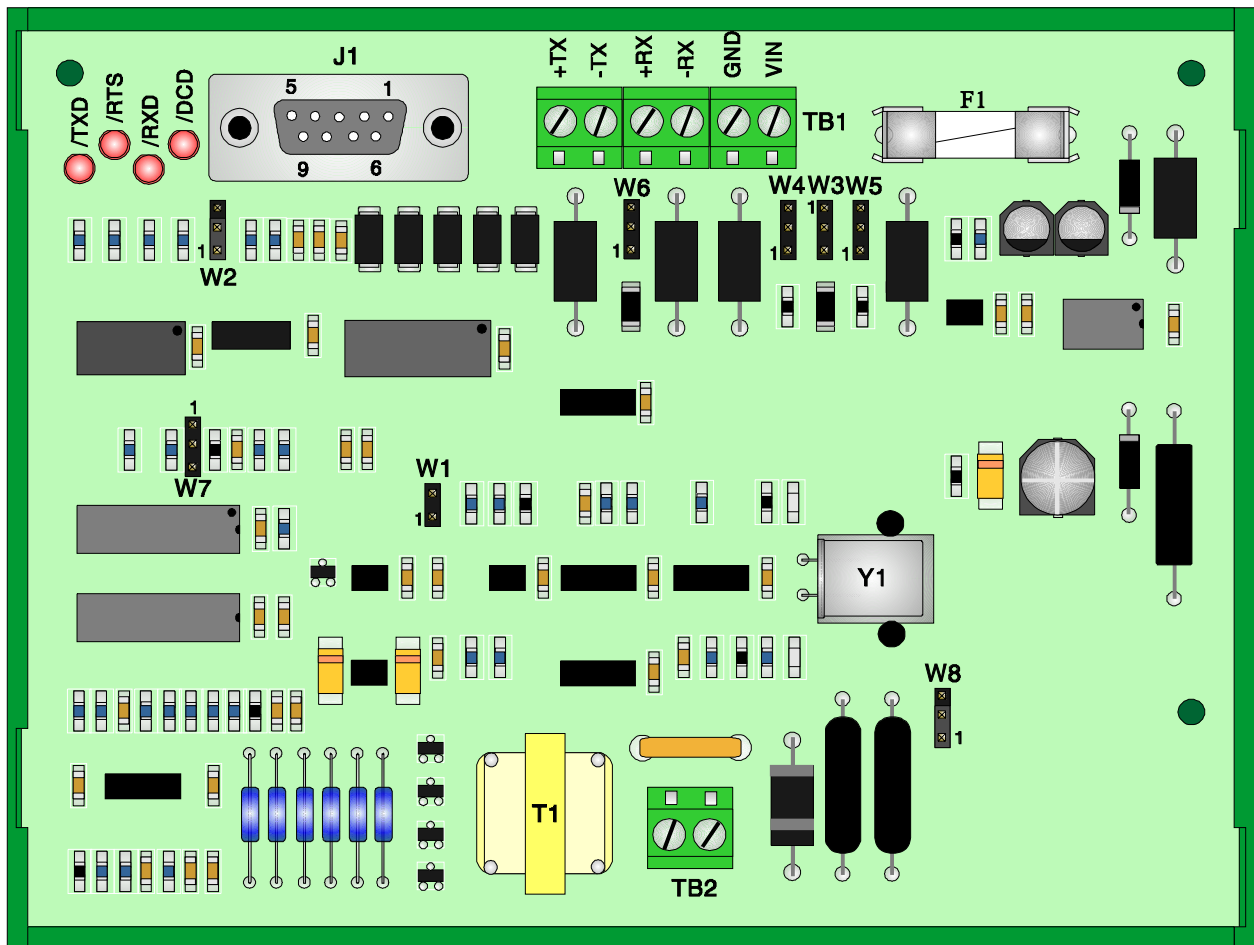

Figure 1 - HART Device Interface Assembly

Table 1 - RS-232 Interface Connector J1 Signal Identification

PIN #	RS-232 SIGNAL	SIGNAL DESCRIPTION	DCE I/O
1	DCD	Data Carrier Detect	Output
2	/TXD	Transmit Data NOT	Input
3	/RXD	Receive Data NOT	Output
5	GND	Ground	-
6	CTS	Clear to Send	Output
7	RTS	Request to Send	Input

Table 2 - Power & RS-485 Interface Connector TB1 Signal Identification

PIN #	NAME	DESCRIPTION
1	VIN +9 - +28 VDC	Input Power (+)
2	GND	Power Ground (-)
3	-RXD	- TX Data from 33XX
4	+RXD	+ TX Data from 33XX
5	-TXD	- RX Data to 33XX
6	+TXD	+ RX Data to 33XX

Table 3 - Slave Device Field Connector TB2 Signal Identification

PIN #	FIELD CONNECT
1	Field Loop (no polarity)
2	Field Loop (no polarity)

Table 4 - HDI Board Jumper Identification and Assignment

JUMPER #	DESCRIPTION	POS. 1-2	POS. 2-3
W1	RS-232 Mode	Disabled	N/A**
W2	3508 Mode (10 mS ON Delay)	Disabled	Enabled
W3	*RS-485 Rcvr. 120 ohm Terminator	Enabled	Disabled
W4	*RS-485 Rcvr. Positive Bias	Enabled	Disabled
W5	*RS-485 Rcvr. Negative Bias	Enabled	Disabled
W6	*RS-485 Xmtr. 120 ohm Terminator	Enabled	Disabled
W7	Status LED Enable	Enabled	Disabled
W8	249 Ohm Loop Resistor	Connected	Open

* = Install on RS-485 End Node

** = W1 is a 2 position Jumper, Installed = RS-232 Disabled/RS-485 Enabled,
Removed = RS-232 Enabled/RS-485 Disabled

1.4.2 HDI Board Status LEDs

There are four status LEDs on the HDI Board. LEDs CR14 through CR17 reflect the status of the active states of Transmit Data NOT (/TXD), Receive Data NOT (/RXD), Data Carrier Detect NOT (/DCD) and Request to Send NOT (/RTS). A logic “0” state of TXD or RXD will

light CR14 or CR15 respectively. The four LEDs can be disabled by placing jumper W7 in position 2-3.

- CR14 = /TXD (Transmit Data NOT)
- CR15 = /RXD (Receive Data NOT)
- CR16 = /DCD (Data Carrier Detect NOT)
- CR17 = /RTS (Request to Send NOT)

1.4.3 HDI Board Circuitry

The HDI board has a built-in $\pm 5V$ DC Switching Power Supply that is fused and operates from a bulk 9V to 30V DC. A blocking diode protects the power supply circuitry from reversed input power conditions.

Except for the Power Supply, the major components of the HART Device Interface board are shown in the block diagram (Figure 2).

There are independent RS-232 and RS-485 transceivers which are jumper selectable. A 120 ohm biasing resistor is jumper selectable for the RS-485 transmit lines. A 120 ohm terminator and biasing resistors are jumper selectable for the RS-485 receive lines.

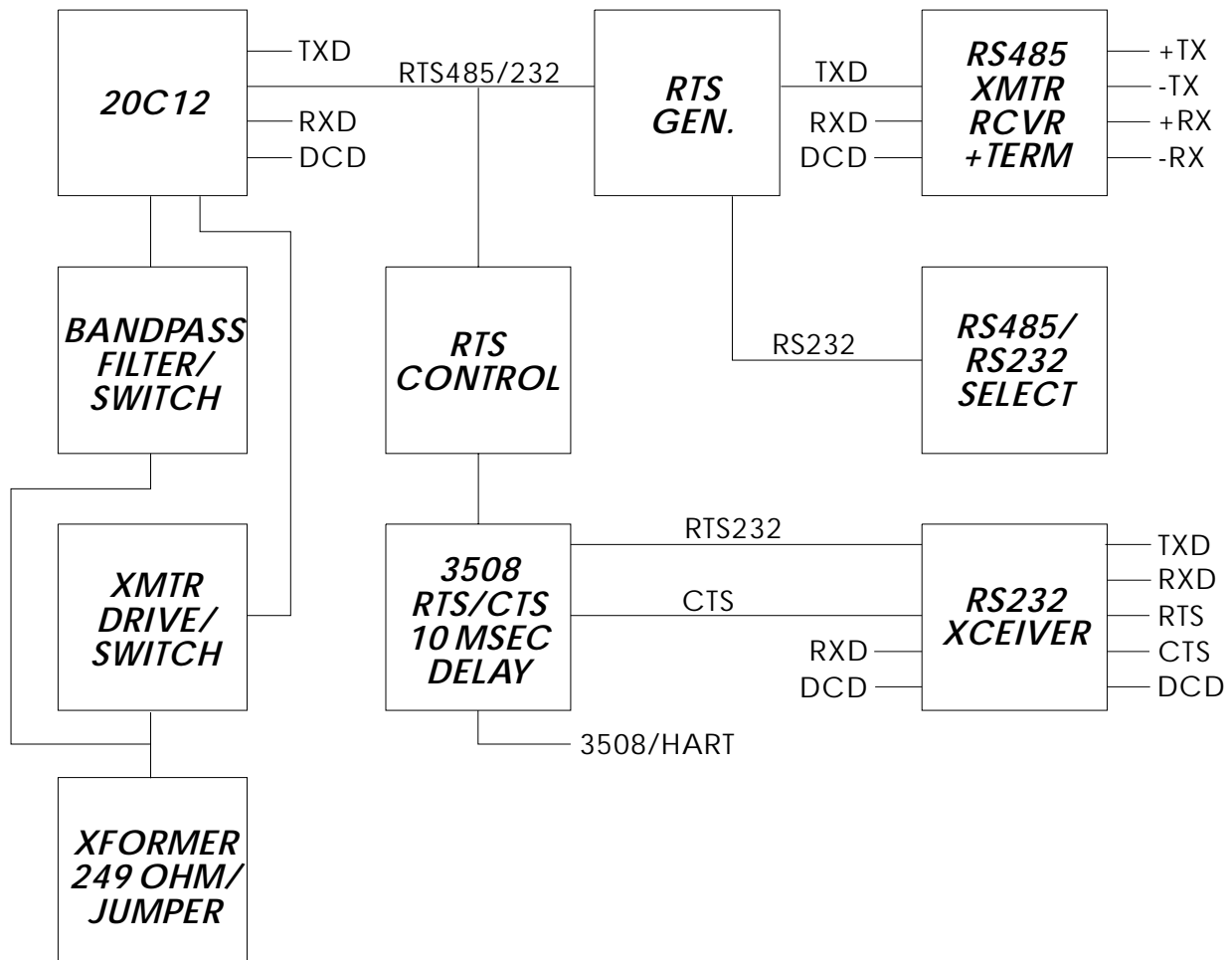

Figure 2 - Block Diagram of BBI HDI Board

When the HDI is configured to communicate with slave devices which support the HART protocol, and the communication mode between the HDI and the 33XX device is RS-232. CTS NOT is asserted 100 microseconds after RTS NOT becomes valid. In the RS-485 mode, RTS NOT is generated by a 1 to 0 transition of TXD. For BBI 3508 applications in RS-232 mode, a 10 millisecond RTS NOT to CTS NOT delay is selected to emulate the existing TIB design. The added combination of RTS232 NOT and RTS485 NOT enables the 20C12 FSK modem's transmit circuitry, enables the CMOS switch to the transformer and disconnects the receive signal to the FSK modem's receiver.

The 20C12 FSK modem operates at Bell 202 standards with a 460.8 KHz clock. The modulated CMOS digital signal from the 20C12 is scaled to a constant $\pm 0.6V$ level via a transformer drive circuit that provides a constant output signal with varying loads. The transformer drive circuit is isolated from the output transformer with a CMOS switch. This switch is only closed during transmission cycles. The received FSK signal is routed through a doubler and bandpass filter to the FSK modem. A CMOS switch disconnects the filtered signal from the input of the FSK receiver during transmit cycles.

The field side of the transformer is AC coupled with a 2.2 μF capacitor to the field devices and to a jumper selectable 249 ohm load resistor.

RS-232 and RS-485 signals are transorb protected from surge transients and electro-static discharge (ESD).

Section 2

CONFIGURATION & CONNECTIONS

2.1 RESTRICTIONS & ASSUMPTIONS

For multidrop configurations, the field devices are placed in a “digital mode” of operation with the loop current for the device set at 4mA or less. The input impedance of the master in receive mode is 249 ohms. The maximum number of field devices that can be placed in parallel with a 24V supply is determined by the following equation: Max. # of Field devices = $\{(24V - V(\text{Field device}) - [4mA \times 249 \times \#(\text{Field Devices})] - [4mA \times \#(\text{Field devices}) \times \text{Wire Resistance}] - 2V_{\text{loop}}\} > 0V$. This calculation implies that the maximum number of transmitters, which require a minimum of 12V to operate in a loop, is 10 when the wire resistance is not included. The power supply voltage must exceed 24V if more than 10 transmitters are to be connected in parallel. *Note: The maximum number of transmitters that can be connected in parallel is not to exceed 15.*

Field devices with a maximum ID number of 15 cannot be mixed with field devices with a maximum ID number of 2²⁴.

2.1.1 HART Slave Devices

The Carrier On Delay and Carrier Off Delay as specified in the HART Foundation Data Link Layer specification, states that the delay from an idle line to/from an acceptable signal level is 5 bit times maximum. For HDIs configured for RS-232 communications mode, the carrier On delay will be met, but, the off delay may exceed the 5 bit time requirement (but the delay will be less than 12 bit times). HART slave devices are required to send a minimum of 5 preambles. The 20C12 FSK Modem located on the HDI board will output receive data within 9 to 15 milliseconds after the transmit cycle is completed. At 1200 baud, one character time is 11×0.833 milliseconds or 10 milliseconds. The slave device will start to transmit the preamble one character time after the end of the last character sent from the master device. The total delay from the end of the last character sent from the master to valid receive data is 25 milliseconds. Since there is a 1 character delay from the HART module, the receive communications driver will synchronize on the third preamble at the latest. The receive communications driver for the HART ACCOL module requires one preamble before the start of data.

For the RS-485 mode, the off delay will be between 12 to 18 milliseconds. This is equivalent to 2 characters. The 20C12 FSK Modem takes 9 to 15 milliseconds to assert Carrier Detect (CD) and valid data. The total delay is 33 milliseconds. The slave device will delay 1 character time, which is 9 milliseconds. The difference is $33 - 9.2 = 23.8$ milliseconds. This is about 2.6 characters. Two valid preambles will be seen by the receive communications driver for the HART ACCOL module, which is sufficient before the start of data.

2.1.2 3508 Smart Transmitters

In the RS-232 communications mode, the HDI can operate properly with 3508 transmitters. The 10 millisecond RTS/CTS delay must be selected.

With existing 33XX firmware, the HDI will not communicate with 3508 TELETRANS when configured in the RS-485 communications mode. A programmable length preamble is required.

2.2 CONFIGURING A SINGLE HDI BOARD

2.2.1 RS-485 Interface - To a Single HDI Board (see Figures 3, 4 & 5)

Note: *The maximum length of an RS-485 cable should not exceed 4000 feet.*

Follow steps 1 through 4 below to configure a single HDI assembly for RS-485/HART interface operation.

1. Install the HDI Assembly in a suitable location (DIN Rail mounted). Connect the power supply (+9V to +30V DC) to TB1 as follows: Pin 1 = + Voltage, Pin 2 = Ground.
2. Connect the HDI board to the HART slaves as shown in Figure 4 (for 4-20mA current sourced transmitters) or to a single HART slave device as shown in Figure 5 (for a +12 to +45 VDC voltage sourced transmitter).
3. Configure the 33XX Port in question for RS-485 operation (see the HART Master Protocol Manual, Document # D4068) and connect the port in question to TB1 of the HDI board (see Table 2 for HDI - TB1 designations) (see Figure 3 for 33XX D-Type RS-485 designations). *Note: With existing 33XX firmware, the HDI board will not communicate with a 3508 TELETRANS when configured for RS-485 operation.*

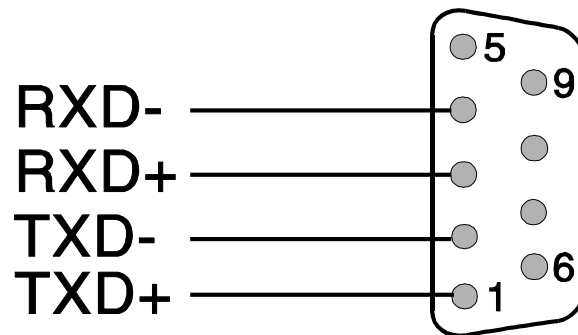
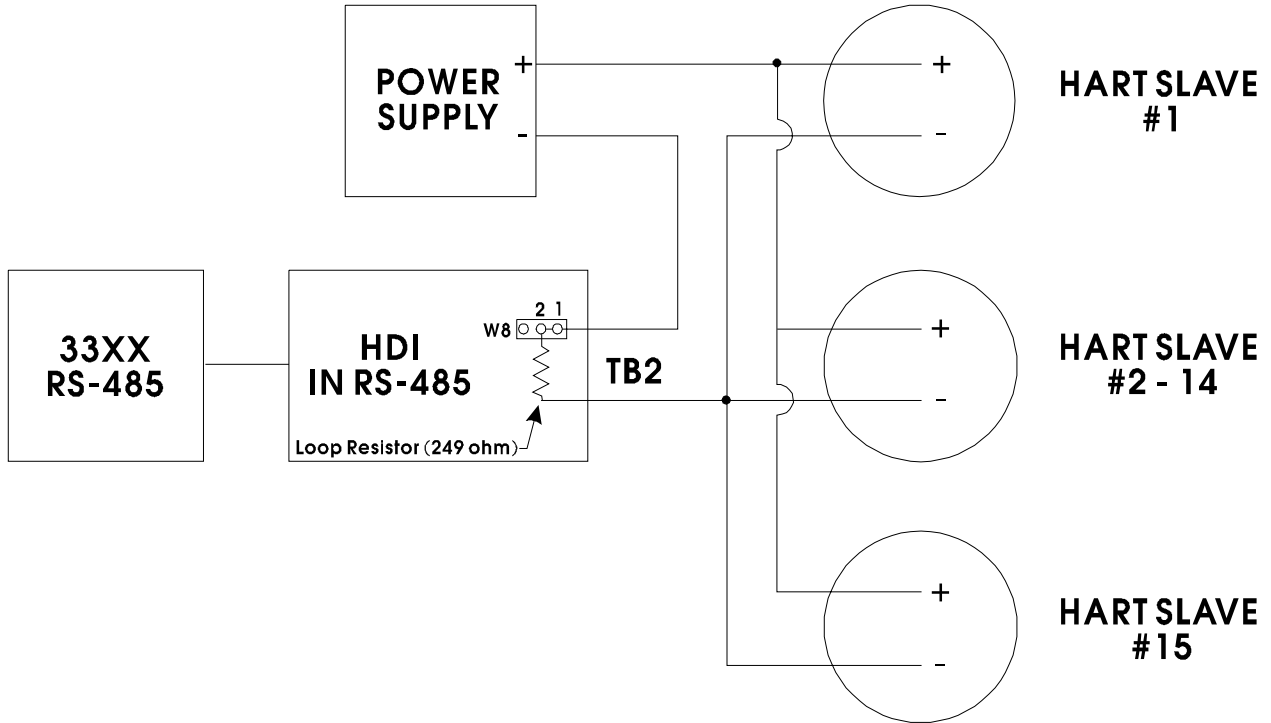

Figure 3 - 33XX RS-485 D-Type Port Assignment

4. Set the HDI board Jumpers as follows:
 - Jumper W1 - RS-232 Mode - in position 1-2 (Disabled).
 - Jumper W2 - In position 1-2 (Disabled) - for all except 3508 Mode.
 - Jumper W3 - In position 1-2 (Enabled) places a 120 ohm termination resistor across the RS-485 receive lines.
 - Jumper W4 - RS-485 Receiver Positive Bias - position 1-2 = Enabled.
 - Jumper W5 - RS-485 Receiver Negative Bias - position 1-2 = Enabled.
 - Jumper W6 - In position 1-2 (Enabled) places a 120 ohm termination resistor across the RS-485 transmit lines.
 - Jumper W7 - In position 1-2 to Enable the Status LEDs, or position 2-3 to disable them.

Jumper W8 - In position 1-2 (Connected) - places a 249 ohm loop resistor into the Power Supply loop (for 4-20 mA Current Loop Transmitters). In position 2-3 for a voltage output slave device.



**Figure 4 - Hart Slaves (Transmitters)(with 4-20 mA Current Source)
Connected to 33XX via HDI Board in RS-485 Mode**

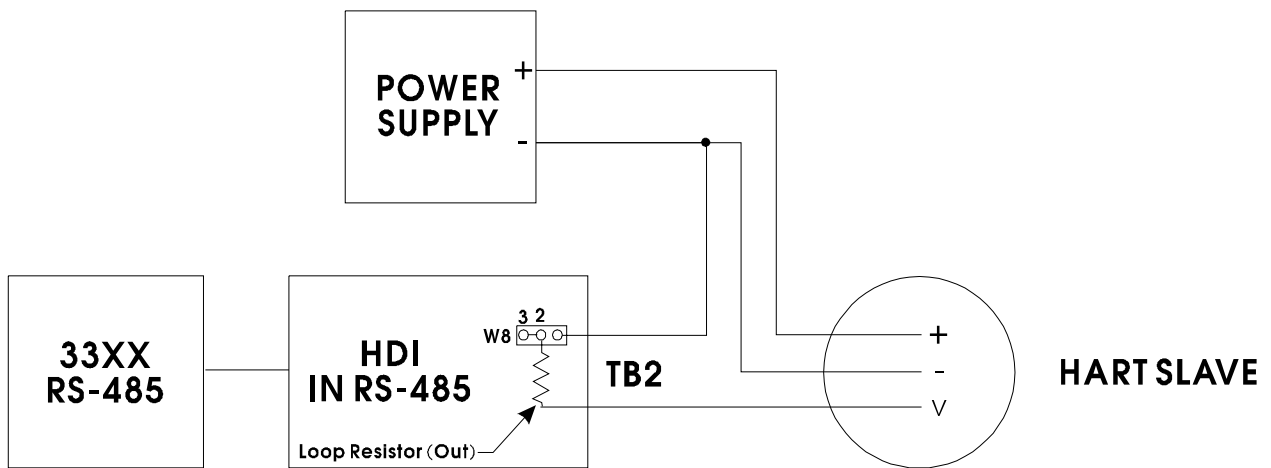

**Figure 5 - Hart Slave (Transmitter)(with +12 to +45 VDC Voltage Source)
Connected to 33XX via HDI Board in RS-485 Mode**

2.2.2 RS-232 Interface - To a Single HDI Board (see Figures 6, 7 & 8)

Follow steps 1 through 4 below to configure a single HDI assembly for RS-232 interface operation.

Note: *The maximum length of an RS-232 cable should not exceed 25 feet.*

1. Install the HDI Assembly in a suitable location (DIN Rail mounted). Connect the power supply (+9V to +30V DC) to TB1 as follows: Pin 1 = + Voltage, Pin 2 = Ground.
2. Connect the HDI board to the HART slaves as shown in Figure 7 (for 4-20mA current sourced transmitters) or to a single HART voltage output slave device as shown in Figure 8.
3. Configure the 33XX Port in question for RS-232 operation (see the HART Master Protocol Manual, Document # D4068 if HART operation is required or the ACCOL II Reference Manual, Document # D4044 when interfacing to a 3508 transmitter). Connect the port in question to J1 of the HDI board (see Table 1 for HDI - J1 designations) (see Figure 6 for 33XX RS-232 cable designations).

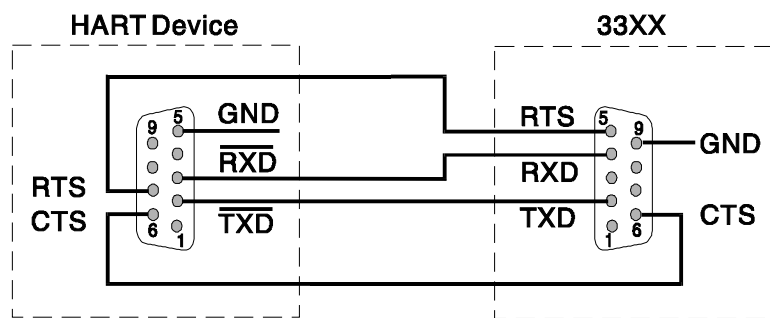

Figure 6 - 33XX RS-232 Cable

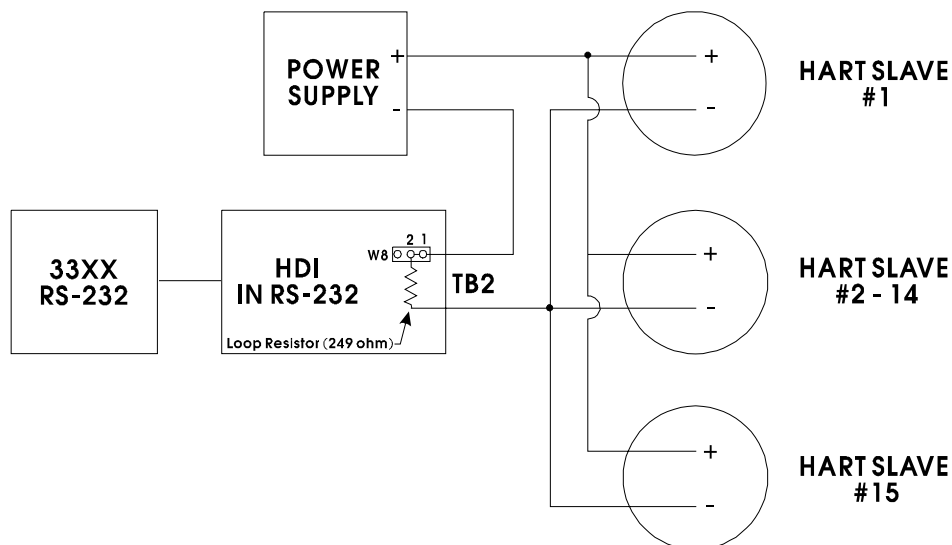

Figure 7 - Hart Slaves (Transmitters)(with 4-20 mA Current Source)
Connected to 33XX via HDI Board in RS-232 Mode

4. Set the HDI board Jumpers as follows:

Jumper W1 - RS-232 Mode - stored in position 1 or 2 (Enabled).

Jumper W2 - In position 2-3 (Enabled) for 3508 Mode - 10 millisecond delay. In position 1-2 (Disabled) - for all except 3508 Mode.

Jumper W3 - In position 2-3 = Disabled.

Jumper W4 - In position 2-3 = Disabled.

Jumper W5 - In position 2-3 = Disabled.

Jumper W6 - In position 2-3 = Disabled.

Jumper W7 - In position 1-2 to Enable the Status LEDs, or position 2-3 to disable them.

Jumper W8 - In position 1-2 (Connected) - places a 249 ohm loop resistor into the Power Supply loop (for 4-20 mA Current Loop Transmitters). In position 2-3 for a HART voltage output slave device.

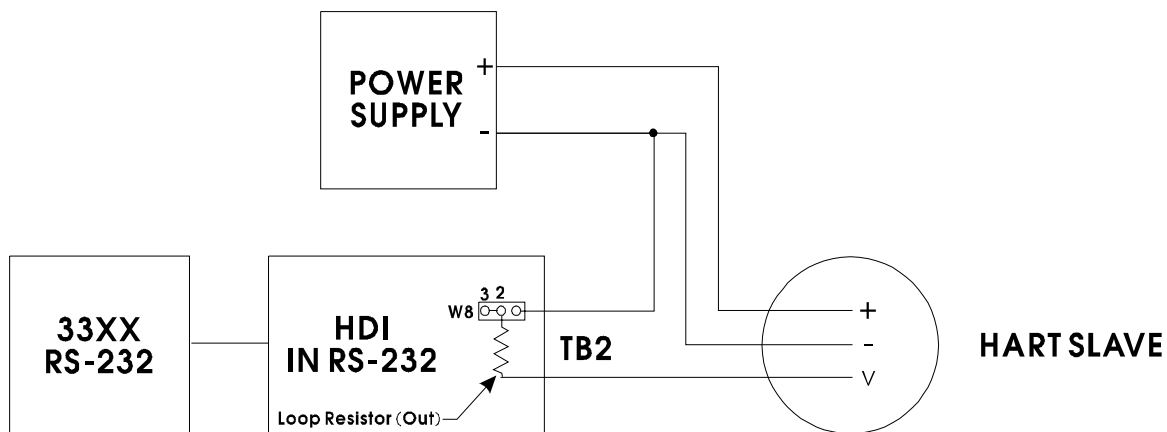

Figure 8 - Hart Slaves (Transmitters) (with +12 to +45 VDC Voltage Source) Connected to 33XX via HDI Board in RS-232 Mode

2.2.3 Configuring Multiple HDI Assemblies into a Single 33XX Master

2.2.3.1 Multiple HDI Boards Configured for RS-485 Operation

When configured for RS-485 operation, more than one HDI board may be used in conjunction with a single 33XX Port to support multiple groups (1 to 15 slave devices interfaced to a single HDI board) of HART slave devices. When so configured, the 33XX port as well as the HDI boards must be configured for RS-485 communications. Figure 9 shows an example of such a network (configured for RS-485 operation). Depending on the type of transmitter, the HDI board will be configured for Current Source or Voltage Source as described earlier.

This configuration requires the use of a BBI Network Interface Box at the 33XX.

Note: The maximum length of an RS-485 cable should not exceed 4000 feet.

Follow steps 1 through 5 below to configure multiple HDI assemblies for RS-485/HART inter-face operation.

1. Install each HDI Assembly in a suitable location (DIN Rail mounted). Connect the power supply (+9V to +30V DC) to TB1 as follows: Pin 1 = + Voltage, Pin 2 = Ground.

2. Connect each HDI board to the HART slaves as shown in Figure 4 (for 4-20mA current sourced transmitters) or to a single HART slave device as shown in Figure 5 (for a +12 to +45 VDC voltage output transmitter).
3. Install a BBI NIB assembly at the 33XX in question. Refer to the appropriate 33XX product manual for information on installing the NIB assembly.
4. Configure the 33XX Port in question for RS-485 operation (see the HART Master Protocol Manual, Document # D4068) and connect the port in question to TB1 of the HDI board (see Table 2 for HDI - TB1 designations) (see Figure 3 for 33XX D-Type RS-485 designations).

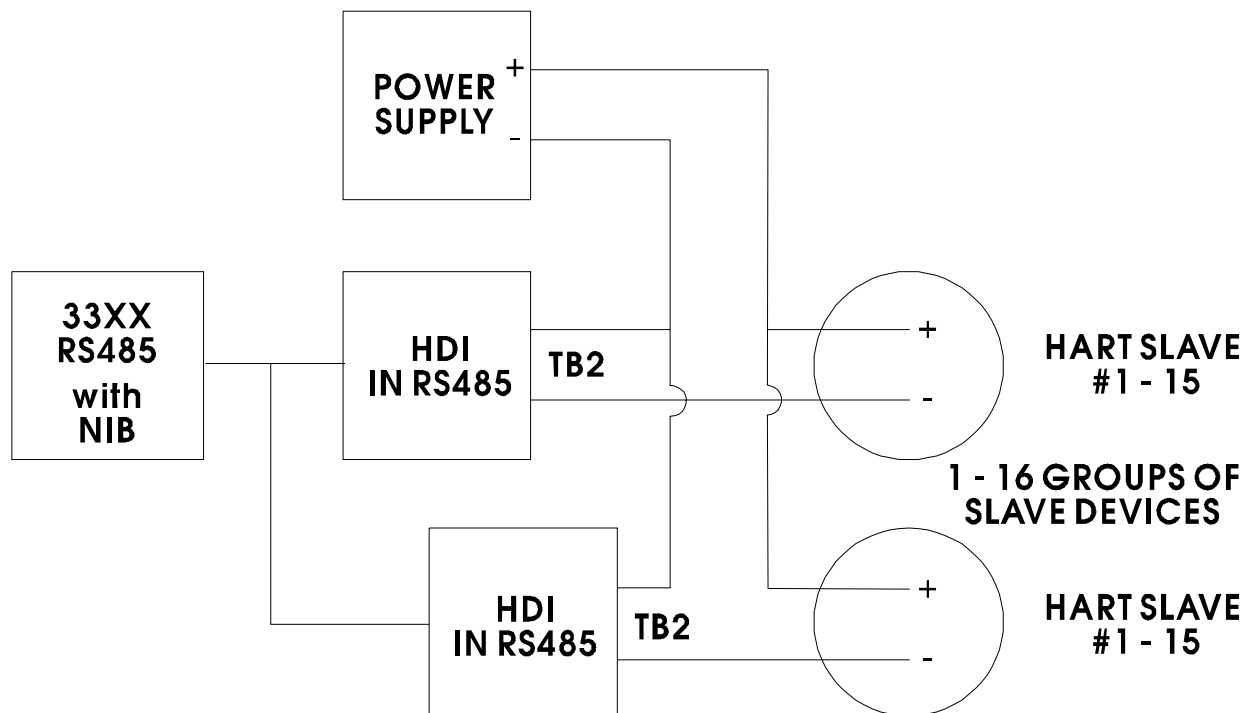

Figure 9 - Multiple HDI Assemblies Connected to Multiple Groups of HART Slaves

5. Set the HDI board Jumpers as follows:
 - Jumper W1 - Installed = RS-485 Mode Enabled.
 - Jumper W2 - In position 1-2.
 - Jumper W3 - In position 1-2 (Enabled) places a 120 ohm termination resistor across the RS-485 receive lines. Jumper W3 should be placed in position 1-2 for the most distant HDI board (End Node) and placed in position 2-3 (Disabled) for all other nodes.
 - Jumper W4 - RS-485 Receiver Positive Bias - position 1-2 = Enabled, position 2-3 = Disabled. Jumper W4 should be placed in position 1-2 for the most distant HDI board (End Node) and placed in position 2-3 (Disabled) for all other nodes.
 - Jumper W5 - RS-485 Receiver Negative Bias - position 1-2 = Enabled, position 2-3 = Disabled. Jumper W5 should be placed in position 1-2 for the most distant HDI board (End Node) and placed in position 2-3 (Disabled) for all other nodes.

- Jumper W6 - In position 1-2 (Enabled) places a 120 ohm termination resistor across the RS-485 transmit lines. Jumper W6 should be placed in position 1-2 for the most distant HDI board (End Node) otherwise in position 2-3 (Disabled).
- Jumper W7 - In position 1-2 to Enable the Status LEDs, or in position 2-3 to disable them.
- Jumper W8 - In position 1-2 (Connected) - places a 249 ohm loop resistor into the Power Supply loop (for 4-20 mA Current Loop Transmitters). In position 2-3 for a HART voltage output slave device.

2.2.3.2 Multiple HDI Boards Configured for RS-232 Operation

When configured for RS-232 operation, no more than one HDI board may be used in conjunction with a single 33XX Port. Each 33XX Port can support a group of up to fifteen (15) HART or five (5) 3508 slave devices. If a single 33XX device must communicate with multiple groups, the HDI board associated with each group must be wired to a discrete 33XX Port, i.e., a Port dedicated to the HDI board (and group) in question. Depending on the type of transmitters, each HDI board will be configured for Current Source or Voltage Source as described earlier.

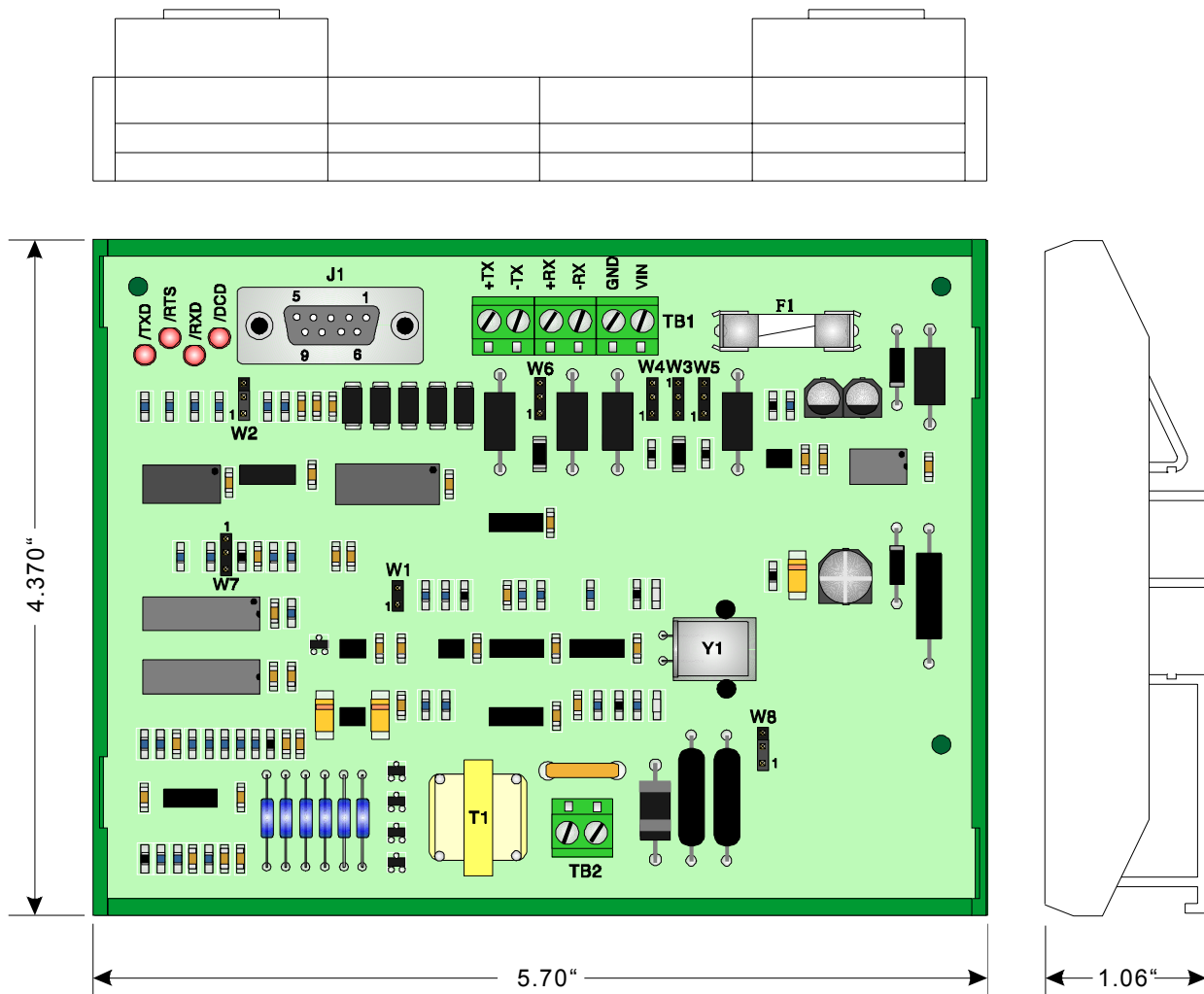

Figure 10 - HART Device Interface Assembly Dimensions

Section 3

SPECIFICATIONS

3.1 HART COMM. PROTOCOL PARAMETERS FOR PHYSICAL LINK

DESCRIPTION	VALUE
Master Transmitted Signal	Min 400 mV p-p Max 600 mV p-p
Slave Transmitted Signal	Min 0.8 mA p-p Max 1.2 mA p-p
Minimum Slave Signal, Converted by a 230 ohm load Maximum Slave Signal, Converted by a 1100 ohm load	184 mV p-p 1320 mV p-p
Receiver Sensitivity (must receive correctly) Receiver Sensitivity (must ignore)	120 mV to 2.0 V p-p 80 mV p-p

3.2 HART DEVICE IMPEDANCE SPECIFICATION

DEVICE	DESIGNATION	VALUE
Primary Master (Including Load Resistor)	Shunt Impedance (Rx)	230 - 1100 ohms
	Max. Source Impedance (Tx)	700 ohms
Secondary Master	Min. Shunt Impedance (Rx)	5 Kohms
	Max. Source Impedance (Tx)	100 ohms
Slave Device	Min. Shunt Resistance	100 Kohms
	Maximum Shunt Capacitance	5000 pF
Miscellaneous Devices (Total)	Min. Shunt Impedance	10 Kohms
	Max. Series Impedance	100 ohms

3.3 HART DEVICE POWER SUPPLY REQUIREMENTS

DESCRIPTION	VALUE
Maximum Ripple (47 to 125 Hz)	0.2V p-p
Maximum Noise (500 Hz to 10 KHz)	1.2mV rms
Maximum Series Impedance (500 Hz to 10 KHz)	10 ohms

3.4 PHASE SHIFT SPECIFICATION

The maximum phase shift for the master or slave at 1200 and 2200 Hz input frequencies is 45 degrees [3dB (0.707) attenuation]. Each device in the loop and the loop wire must be considered for capacitance and resistance.

3.5 PERFORMANCE SPECIFICATION

HDI Communications Interface: RS-232/485 Interface - switch selectable

HART Device Interface: Current Input Device

3.5 PERFORMANCE SPECIFICATION (Continued)

FSK Modem: Bell 202 Compatibility (1200 Hz/2200 Hz Modulation)

Power Consumption: RS-232 @ 9V - 35.57mA
@ 28V - 17.9mA
RS-485 @ 9V - 42.66mA when receiving
@ 28V - 20.09mA when receiving

3.6 ENVIRONMENTAL SPECIFICATIONS

Temperature: Operating - (-40 to 70)°C (-40 to 152)°F
Storage - (-40 to 85)°C (-40 to 185)°F

Relative Humidity: 15 - 95% non-condensing

Vibration: 1G for 10 - 150 Hz
0.5G for 150 - 2000 Hz

RFI Susceptibility: 10V/Meter - 20MHz to 500MHz

HART® Device Interface
Special Instructions for Class I, Division 2 Hazardous Locations

1. The BBI Highway Addressable Remote Transducer (HART) Device Interface (HDI) is listed by Underwriters Laboratories (UL) as nonincendive and is suitable for use in Class I, Division 2, Groups A, B, C and D hazardous locations or nonhazardous locations only. Read this document carefully before installing a nonincendive BBI HART Device Interface. In the event of a conflict between the HART Device Interface User Manual (PIP-HART33XX) and this document, always follow the instructions in this document.
2. Wiring must be performed in accordance with Class I, Division 2 wiring methods as defined in Article 501-4 (b) of the National Electrical Code, NFPA 70 for installations within the United States, or as specified in Section 18-152 of the Canadian Electrical Code for installation in Canada.
3. **WARNING: EXPLOSION HAZARD - Substitution of components may impair suitability for use in Class I, Division 2 environments.**
4. **WARNING: EXPLOSION HAZARD - When situated in a hazardous location, turn off power before servicing/replacing the unit and before installing or removing I/O wiring.**
5. **WARNING: EXPLOSION HAZARD - Do Not disconnect equipment unless the power has been switched off or the area is known to be nonhazardous.**

Bristol Babcock

PART OF THE  FKI GROUP OF COMPANIES

1100 Buckingham Street
Watertown, CT 06795
Phone: (860) 945-2200
Fax: (860) 945-2213
Website: www.bristolbabcock.com

U.S.A. Locations:

Northern Region

Bristol Babcock Inc.
1100 Buckingham Street
Watertown, CT 06795
Phone: (860) 945-2381
Fax: (860) 945-2525
NorthernUS@bristolbabcock.com

Southwest Region

Bristol Babcock Inc.
2000 Governor's Circle
Suite F
Houston, TX 77092-8731
Phone: (713) 685-6200
Fax: (713) 681-7331
SouthwestUS@bristolbabcock.com

Western Region

Bristol Babcock Inc.
1609 South Grove Avenue
Suites 106 & 107
Ontario, CA 91761
Phone: (909) 923-8488
Fax: (909) 923-8988
WesternUS@bristolbabcock.com

Southeast Region

Bristol Babcock Inc.
317 S. North Lake Blvd.
Suite 1016
Altamonte Springs, FL 32701
Phone: (407) 740-7084
Fax: (407) 629-2106
SoutheastUS@bristolbabcock.com

Helicoid Instruments

1100 Buckingham Street
Watertown, CT 06795
Phone: (860) 945-2218
Fax: (860) 945-2213
jmcgrail@bristolbabcock.com

Dallas District Office

Bristol Babcock Inc.
777 South Central
Expressway
Suite 1-C
Richardson, TX 75080
Phone: (972) 238-8197
Fax: (972) 238-8198
dallas@bristolbabcock.com

Sales Office New Mexico

Bristol Babcock Inc.
906 San Juan Blvd., Suite A
Farmington, NM 87401
Phone: (505) 320-5046
Fax: (505) 327-3273
NewMexUS@bristolbabcock.com

Communications Technology Group

Bristol Babcock Inc.
317 S. North Lake Blvd.
Suite 1016
Altamonte Springs, FL 32701
Phone: (407) 629-9464
Fax: (407) 629-2106
orlandoRFgroup@bristolbabcock.com

International Affiliates:

Canada

Bristol Babcock, Canada
234 Attwell Drive
Toronto, Ont. M9W 5B3
Canada
PH: 416-675-3820
FAX: 416-674-5129
info@bristolbabcock.ca

Mexico

BBI, S.A. de C.V.
Ejercito Nacional No. 718, 4
Piso
Colonia Polanco
Mexico, D.F. 11560
Mexico
PH: 52-555-254-5281
FAX: 52-555-254-3408
Mexico@bristolbabcock.com

United Kingdom

Bristol Babcock Ltd.
Vale Industrial Estate
Stourport Road
Kidderminster
Worcestershire DY11 7QU
United Kingdom
PH: +44 (0) 1562 820001
FAX: +44 (0) 1562 746721
enquiries@bristol-babcock.com

Australia

Bristol Babcock, Inc.
22 Hastie St.
PO Box 1987
Banbury, Western Australia
6230
PH: 61 (0)8 9791 3654
FAX: 61 (0)8 9791 3173
dtrench@bdsa.com.au

Calgary Office

Bristol Babcock, Canada
3812 Edmonton Trail N.E.
Calgary, Alberta T2E 5T6
Canada
PH: 403-265-4808
FAX: 403-233-2914
janetl@bristolbabcock.ca

Villahermosa Office

BBI, S.A. de C.V.
Av. Plomo No.2
Bodega No. 1 - Ciudad
Industrial
Villahermosa, Tabasco 86010
Mexico
PH: 52-993-353-3142
FAX: 52-993-353-3145
bbivsa@prodigy.net.mx

Middle East

Bristol Babcock Ltd.
Vale Industrial Estate
Stourport Road
Kidderminster
Worcestershire DY11 7QU
United Kingdom
PH: +44 (0) 1562 820001
FAX: +44 (0) 1562 746721
enquiries@bristol-babcock.com

This page provides links that allow you to return to a manual's Table of Content (T.O.C) or return to the first page of the Main Menu. Links are provided by selecting the appropriate Link Text Box.

**Select the
Appropriate
Link Text Box**



Return to the T.O.C.

Return to the Main Menu