

Fisher™ EWD, EWS, and EWT Valves through NPS 12x8

Contents

| | |
|---|----|
| Introduction | 1 |
| Scope of Manual | 1 |
| Description | 3 |
| Specifications | 3 |
| Educational Services | 4 |
| Installation | 4 |
| Inverted Globe Valve Applications (Actuator below valve) | 6 |
| Maintenance | 7 |
| Packing Lubrication | 8 |
| Packing Maintenance | 10 |
| Replacing Packing | 11 |
| Trim Maintenance | 14 |
| Trim Removal | 15 |
| Lapping Metal Seats | 16 |
| Valve Plug Maintenance | 17 |
| Trim Replacement | 19 |
| Retrofit: Installing C-seal Trim | 20 |
| Replacement of Installed C-seal Trim | 24 |
| Trim Removal (C-seal Constructions) | 24 |
| Lapping Metal Seats (C-seal Constructions) .. | 25 |
| Remachining Metal Seats (C-seal Constructions) | 25 |
| Trim Replacement (C-seal Constructions) ... | 26 |
| ENVIRO-SEAL™ Bellows Seal Bonnet | 27 |
| Parts Ordering | 32 |
| Parts Kits | 33 |
| Parts List | 36 |

Figure 1. Fisher NPS 12x6 EW Series Valve With
667 Actuator



W2777-2*

Introduction

Scope of Manual

This instruction manual includes installation, maintenance, and parts information for Fisher NPS 4x2 through 12x8 EWD, EWS, and EWT valves (figure 1). Refer to separate manuals for instructions covering the actuator and accessories.

Do not install, operate, or maintain an EW valve without being fully trained and qualified in valve, actuator, and accessory installation, operation, and maintenance. To avoid personal injury or property damage, it is important to carefully read, understand, and follow all the contents of this manual, including all safety cautions and warnings. If you have any questions about these instructions, contact your [Emerson sales office](#) before proceeding.

Table 1. Specifications

| | |
|---|---|
| <p>End Connection Styles</p> <p>Flanged Ends: CL300, CL600, or CL900 Raised-face or ring-type joint flanges per ASME B16.5</p> <p>Buttwelding Ends: Styles per ASME B16.25 schedules consistent with ASME B16.34 are: Schedules ■ 40 or ■ 80 for all CL300 and CL600 valves, Schedule ■ 80 or ■ XXS for NPS 8x6 CL900 valves, or Schedule ■ 80, ■ 100, or ■ 120 for NPS 12x8 CL900 valves.</p> <p>Maximum Inlet Pressures, Temperatures, and Pressure Drops⁽¹⁾</p> <p>Consistent with applicable ■ CL300, ■ CL600⁽²⁾, or ■ CL900⁽³⁾ pressure/temperature ratings per ASME B16.34, but do not exceed the pressure, temperature, and pressure drop conditions specified when the valve was ordered. Also see the Installation section.</p> <p>Also see Bulletin 80.3:010 WhisperFlo™ Aerodynamic Attenuation Trims, D102362X012</p> <p>Shutoff Classifications</p> <p>See table 2</p> <p>C-seal trim: High-temperature, Class V per ANSI/FCI 70-2 and IEC 60534-4</p> <p>See table 3</p> <p>WhisperFlo Trim:</p> <ul style="list-style-type: none"> ■ Class IV per ANSI/FCI 70-2 and IEC 60534-4 ■ Others per application <p>Flow Characteristics</p> <p>Standard Cages: ■ Linear, ■ quick opening, or ■ equal percentage</p> <p>Whisper Trim™ and Cavitrol™ Cages: Linear</p> <p>WhisperFlo Trim: Linear (restricted linear cages and special, characterized cages are available--consult your Emerson sales office)</p> <p>Flow Directions</p> <p>EWS and Standard Cage: Normally up</p> <p>EWD or EWT with Standard Cage: Normally down</p> | <p>Whisper Trim Cages: Always up</p> <p>Cavitrol Cages: Always down</p> <p>WhisperFlo Trim: Flow up (standard)—through the seat ring and out through the cage orifices</p> <p>Approximate Weights</p> <p>See table 4</p> <p>WhisperFlo Trim Material and Selection</p> <ul style="list-style-type: none"> ■ 410 Stainless Steel ■ Others per application <p>See appropriate valve body bulletin</p> <p>WhisperFlo Pressure/Temperature Capability</p> <ul style="list-style-type: none"> ■ -29 to 427°C (-20 to 800°F) ■ Others per application <p>See appropriate valve body bulletin for complementary information</p> <p>WhisperFlo Aerodynamic Trim Pressure Ratings^(1,2)</p> <p>Up to 1500 psi drop</p> <p>WhisperFlo Velocity Limits</p> <p>WhisperFlo trim is designed for 0.3 MACH as an inherent outlet velocity limit. Variations higher and lower may be applied per special applications</p> <p>WhisperFlo Rangeability</p> <p>100:1</p> <p>WhisperFlo Noise Attenuation</p> <p>Approximately -40 dBA maximum depending on the $\Delta P/P_1$ ratio per IEC 534-8-3 calculation procedure</p> <p>See Fisher Specification Manager</p> <p>Additional Specifications</p> <p>For specifications such as materials, port diameters, valve plug travels, yoke boss diameters, and stem diameters, refer to the Parts List</p> |
|---|---|

1. The pressure or temperature limits in this manual and any applicable standard limitations should not be exceeded.
 2. Certain bonnet bolting material selections may require a CL600 easy-e valve assembly to be derated. Contact your Emerson sales office.
 3. There are two different CL900 NPS 8x6 valve bodies, one for use only with Cavitrol III cages and the other for use with all other constructions. A CL900 valve with Cavitrol III cage can take full CL900 pressure drops. For information on other NPS 8x6 constructions that can take full CL900 pressure drops, contact your Emerson sales office. All other trim constructions are limited to CL600 pressure/temperature limits even though installed in a CL900 valve.

Figure 2. Cutaway Detail of the Fisher WhisperFlo Trim, Valve Body Typical

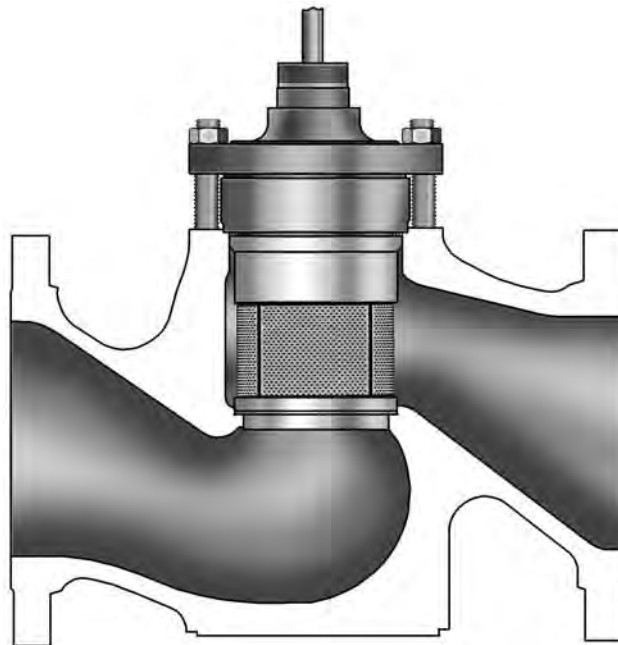

Description

These single-port globe-style valves have cage guiding, clamped seat rings, and push-down-to-close valve plug action. Valve configurations are as follows:

EWD: Balanced valve plug with metal-to-metal seating for all general applications over a wide range of pressure drops and temperatures.

C-seal trim is available for EWD valves, CL300 and CL600, in sizes NPS 6x4x2-1/2, 6x4, 8x4, 8x6, 12x6, 10x8, and 12x8.

With C-seal trim, a balanced valve can achieve high-temperature, Class V shutoff. Because the C-seal plug seal is formed from metal (N07718 nickel alloy) rather than an elastomer, a valve equipped with the C-seal trim can be applied in processes with a fluid temperature of up to 593°C (1100°F), provided other material limits are not exceeded.

EWS: Unbalanced valve plug with metal-to-metal or optional metal-to-PTFE seating for all general applications requiring better shutoff capabilities than can be obtained with the EWD valve.

EWT: Balanced valve plug with either metal-to-PTFE seating (standard for all except Cavitrol III cages) for stringent shutoff requirements or metal-to-metal seating (standard for Cavitrol III cages, optional for all others) for higher temperatures.

Control valves with WhisperFlo cages (figure 2) provide additional attenuation for aerodynamic noise in very demanding vapor or gas applications with high-pressure drops. A WhisperFlo cage with an appropriately sized valve body is designed to reduce the noise level up to -40 dBA. For special applications, -50 dBA attenuation can be achieved.

Specifications

Typical specifications for these valves are shown in table 1.

Table 2. Shutoff Classification Per ANSI/FCI 70-2 and IEC 60534-4

| Valve | Seating | Shutoff Class |
|--|---------|--|
| EWD | Metal | II (standard) |
| | | III (optional for NPS 6x4 through 12x6 valves with optional single graphite piston ring or for NPS 10x8 and 12x8 valves with optional double piston rings) |
| | | IV (optional for NPS 6x4 through 12x8 valves with optional multiple graphite piston rings) |
| EWS | Metal | IV (standard) |
| | | V (optional, consult your Emerson sales office) |
| EWS | PTFE | VI |
| EWT with all except Cavitrol III cages | PTFE | Standard Air Test (maximum leakage is 0.05 mL/min/psid/inch port diameter) |
| | | V (optional) |
| | Metal | IV (standard) |
| EWT with 1-stage Cavitrol III cage | Metal | V (optional) ⁽¹⁾ |
| | | IV (standard) |
| EWT with 2-stage Cavitrol III cage | Metal | V (optional) |
| | | V |

1. Class V shutoff for EWT requires spring loaded seal ring, radius-seat plug, wide-bevel seat ring, and seat lapping. Not available with 8-inch port, quick-opening cage. Not available with S31600 (316 SSI) valve plug and seat ring.

Table 3. Additional Shutoff Classification for C-seal Trim Per ANSI/FCI 70-2 and IEC 60534-4

| Valve | Valve Size, NPS | Port Diameter, Inches | Cage Style | Leakage Class |
|-----------------------|-----------------|-----------------------|---|--|
| EWD (CL300, CL600) | 6x4x2-1/2 | 2.875 | Equal Percentage, Linear, Whisper I, Cavitrol III (2-stage) | V (for port diameters from 2.875 through 8-inch with optional C-seal trim) |
| | 6x4 8x4 | 4.375 | Equal Percentage, Linear, Whisper I, Cavitrol III (1-stage) | |
| | 8x6 and 12x6 | 5.375 | Whisper III (A3, B3, D3, D3), Cavitrol III (2-stage) | |
| | 8x6 12x6 | 7 | Equal Percentage, Linear, Whisper I, Cavitrol III (1-stage) | |
| | 10x8 12x8 | 8 | Equal Percentage, Linear, Whisper I, Cavitrol III (1-stage) | |

Educational Services

For information on available courses for the Fisher EW valve, as well as a variety of other products, contact:

Emerson Automation Solutions
Educational Services - Registration
Phone: 1-641-754-3771 or 1-800-338-8158
E-mail: education@emerson.com
emerson.com/fishervalvetraining

Installation

⚠ WARNING

Always wear protective gloves, clothing, and eyewear when performing any installation operations to avoid personal injury.

Personal injury or equipment damage caused by sudden release of pressure or bursting of parts may result if the valve assembly is installed where service conditions could exceed the limits given in table 1 or on the appropriate nameplates. To avoid such injury or damage, provide a relief valve for overpressure protection as required by government or accepted industry codes and good engineering practices.

Check with your process or safety engineer for any additional measures that must be taken to protect against process media.

If installing into an existing application, also refer to the WARNING at the beginning of the Maintenance section in this instruction manual.

CAUTION

When ordered, the valve configuration and construction materials were selected to meet particular pressure, temperature, pressure drop and controlled fluid conditions. Responsibility for the safety of process media and compatibility of valve materials with process media rests solely with the purchaser and end-user. Since some body/trim material combinations are limited in their pressure drop and temperature ranges, do not apply any other conditions to the valve without first contacting your [Emerson sales office](#).

Before installing the valve, inspect the valve and pipelines for any damage and any foreign material which may cause product damage.

Table 4. Approximate Weights

| END CONNECTION | VALVE SIZE, NPS | | | | | | | | | | | | | | |
|----------------------|-----------------|-----|-----|-----|-----|-----|-----|-----|------|------|------|------|------|------|------|
| | 4X2 | | 6X4 | | 8X4 | | 8X6 | | 10X8 | | 12X6 | | 12X8 | | |
| | Kg | Lb | Kg | Lb | Kg | Lb | Kg | Lb | Kg | Lb | Kg | Lb | Kg | Lb | |
| CL300 (flanged only) | 84 | 185 | 150 | 330 | 234 | 515 | 284 | 625 | 567 | 1250 | 500 | 1102 | 653 | 1440 | |
| CL600 | Flanged | 100 | 220 | 195 | 430 | 272 | 600 | 308 | 680 | 744 | 1640 | 721 | 1590 | 857 | 1890 |
| | Buttwelding | 61 | 135 | 122 | 270 | 177 | 390 | 272 | 600 | 512 | 1130 | 526 | 1160 | 658 | 1450 |
| CL900 | Flanged | --- | --- | --- | --- | --- | --- | 612 | 1350 | --- | --- | --- | --- | 1361 | 3000 |
| | Buttwelding | --- | --- | --- | --- | --- | --- | 454 | 1000 | --- | --- | --- | --- | 1293 | 2850 |

CAUTION

If hoisting the valve, use a nylon sling to protect the surfaces. Carefully position the sling to prevent damage to the actuator tubing and any accessories. Also, take care to prevent people from being injured in case the hoist or rigging slips unexpectedly. Refer to table 4 for valve assembly weights. Be sure to use adequately sized hoists and chains or slings to handle the valve.

1. Before installing the valve, inspect the valve body cavity and associated equipment for any damage and any foreign material.
2. Make certain the valve body interior is clean, that pipelines are free of foreign material, and that the valve is oriented so that pipeline flow is in the same direction as the arrow on the side of the valve.
3. Install the control valve assembly in any orientation unless limited by seismic criteria. However, the normal method is with the actuator vertical above the valve. Other positions may result in uneven valve plug and cage wear and in improper operation. With some valves, the actuator may also need to be supported when it is not vertical. For more information, consult your Emerson sales office.

Note

If installing a valve with small internal flow passages, such as with WhisperFlo, Whisper Trim, or Cavitrol cages, consider installing an upstream strainer to prevent the lodging of particles in these passages. This is especially important if the pipeline cannot be thoroughly cleaned or if the flowing medium is not clean.

4. Use accepted piping and welding practices when installing the valve in the line. For flanged valve bodies, use a suitable gasket between the valve body and pipeline flanges.

CAUTION

Depending on valve body materials used, post weld heat treating may be required. If so, damage to internal elastomeric and plastic parts, as well as internal metal parts is possible. Shrink-fit pieces and threaded connections may also loosen. In general, if post weld heat treating is to be performed, remove all trim parts. Contact your [Emerson sales office](#) for additional information.

5. With a leak-off bonnet construction, remove the pipe plugs (keys 14 and 16, figure 21) from the bonnet to hook up the leak-off piping. If continuous operation is required during inspection or maintenance, install a three-valve bypass around the control valve assembly.
6. If the actuator and valve are shipped separately, refer to the actuator mounting procedure in the appropriate actuator instruction manual.

⚠ WARNING

Personal injury could result from packing leakage. Valve packing was tightened before shipment; however, the packing might require some readjustment to meet specific service conditions. Check with your process or safety engineer for any additional measures that must be taken to protect against process media.

Valves with ENVIRO-SEAL live-loaded packing or HIGH-SEAL live-loaded packing will not require this initial re-adjustment. See Fisher instruction manuals, ENVIRO-SEAL Packing System for Sliding-Stem Valves, [D101642X012](#), or HIGH-SEAL Live-Loaded Packing System, [D101453X012](#), (as appropriate), for packing instructions. If you wish to convert your present packing arrangement to ENVIRO-SEAL packing, refer to the retrofit kits listed in the parts kit sub-section near the end of this manual.

Inverted Globe Valve Applications (Actuator below valve)

Due to space restrictions in your application, you may be required to mount the valve/actuator assembly in an inverted orientation, with the actuator positioned below the valve. If so, the following procedures will help you with disassembly and assembly techniques.

⚠ WARNING

Avoid personal injury or property damage caused by components dropping.

With the valve/actuator upside down, components may drop during disassembly or assembly. Be careful not to position yourself below the valve in the path of falling parts.

As the bonnet/plug/cage is lowered from the valve body, the center of gravity will be above the lifting points. Take care to prevent the assembly from tipping over as it is lowered. Either leave the actuator attached to the plug and bonnet, attach straps to the stem, or provide other means to prevent tipping.

Disassembly

1. Provide adequate support to the actuator while removing it from the bonnet.

2. Provide adequate support to the bonnet while removing the bonnet nuts.
3. Be aware that the bonnet/plug/cage may tip over as they are lowered from the valve body. Make provision to prevent tipping.
4. Be aware that the cage and seat ring may not come out with the bonnet and plug/stem assembly. If this occurs, make provision to support these parts, as they may fall out unexpectedly.

Assembly

1. Start this assembly procedure with the plug/stem assembly already installed in the bonnet.
2. Put the gaskets and cage onto the bonnet and plug.
3. Place the seat ring with the seat ring gasket onto the cage, if applicable with the valve design.
4. Raise this bonnet/plug/cage assembly up into the valve body. Make provision to prevent tipping of these parts as they are being raised into the valve body.
5. Torque the bonnet nuts.
6. Mount the actuator.

Maintenance

Valve parts are subject to normal wear and must be inspected and replaced as necessary. Inspection and maintenance frequency depends on the severity of service conditions. This section includes instructions for packing lubrication, packing maintenance, trim maintenance, lapping metal seats, and ENVIRO-SEAL bellows seal bonnet replacement. All maintenance operations may be performed with the valve in the line.

⚠ WARNING

Avoid personal injury or property damage from sudden release of process pressure. Before performing any maintenance operations:

- Do not remove the actuator from the valve while the valve is still pressurized.
- Always wear protective gloves, clothing, and eyewear when performing any maintenance operations to avoid personal injury.
- Disconnect any operating lines providing air pressure, electric power, or a control signal to the actuator. Be sure the actuator cannot suddenly open or close the valve.
- Use bypass valves or completely shut off the process to isolate the valve from process pressure. Relieve process pressure on both sides of the valve. Drain the process media from both sides of the valve.
- Vent the pneumatic actuator loading pressure and relieve any actuator spring precompression.
- Use lock-out procedures to be sure that the above measures stay in effect while you work on the equipment.
- The valve packing box may contain process fluids that are pressurized, *even when the valve has been removed from the pipeline*. Process fluids may spray out under pressure when removing the packing hardware or packing rings, or when loosening the packing box pipe plug.
- Check with your process or safety engineer for any additional measures that must be taken to protect against process media.

CAUTION

Follow instructions carefully to avoid damaging the product surfaces, which could result in damage to the product.

Note

Whenever a gasket seal is disturbed by removing or shifting gasketed parts, install a new gasket upon reassembly. This is necessary to ensure a good gasket seal because the used gasket may not seal properly.

Figure 3. Lubricator and Lubricator/Isolating Valve (optional)

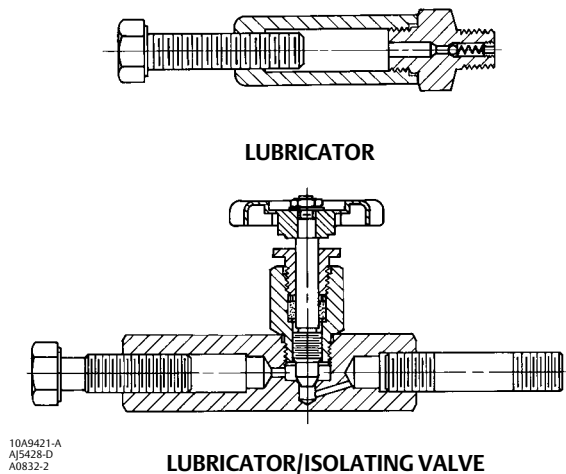

Packing Lubrication

CAUTION

Do not lubricate graphite packing. Graphite packing is self-lubricated. Additional lubrication may result in slip-stick movement of the valve.

Note

ENVIRO-SEAL or HIGH-SEAL packing does not require lubrication.

⚠ WARNING

To avoid personal injury or property damage resulting from fire or explosion, do not lubricate packing used in oxygen service or in processes with temperatures over 260°C (500°F).

If a lubricator or lubricator/isolating valve (figure 3) is provided for PTFE/composition or other packings that require lubrication, it will be installed in place of the pipe plug (key 14, figure 21). Use a good quality silicon-base lubricant. Do not lubricate packing used in oxygen service or in processes with temperatures over 260°C (500°F). To operate the lubricator, simply turn the cap screw clockwise to force the lubricant into the packing box. The lubricator/isolating valve operates the same way, except open the isolating valve before turning the cap screw and then close the isolating valve after lubrication is completed.

Figure 4. PTFE V-Ring Packing Arrangements

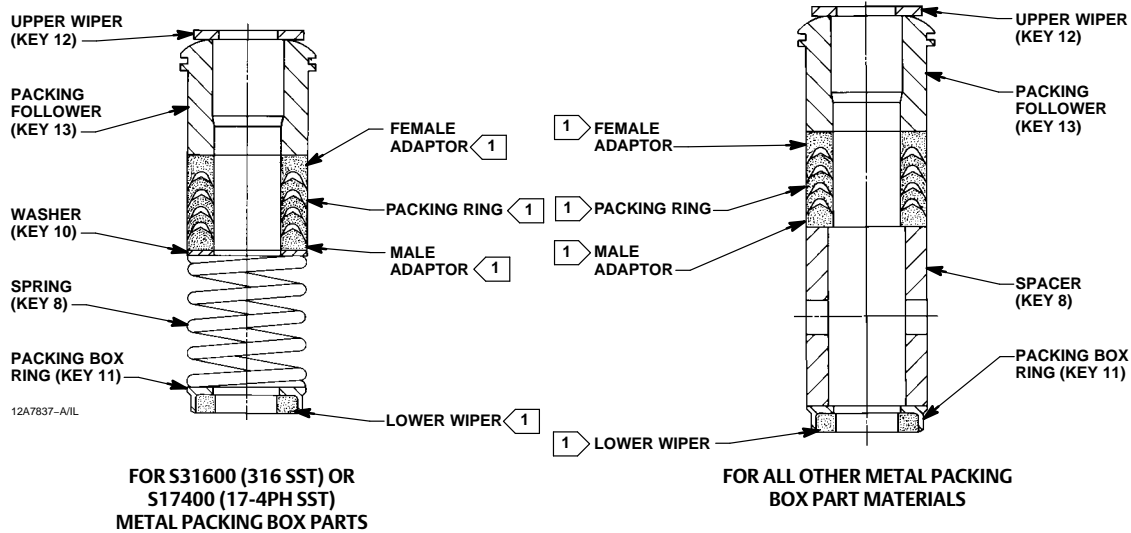

SINGLE ARRANGEMENTS

NOTE:
 1 PACKING SET (KEY 6) (2 REQ'D FOR DOUBLE ARRANGEMENTS).
 B2398

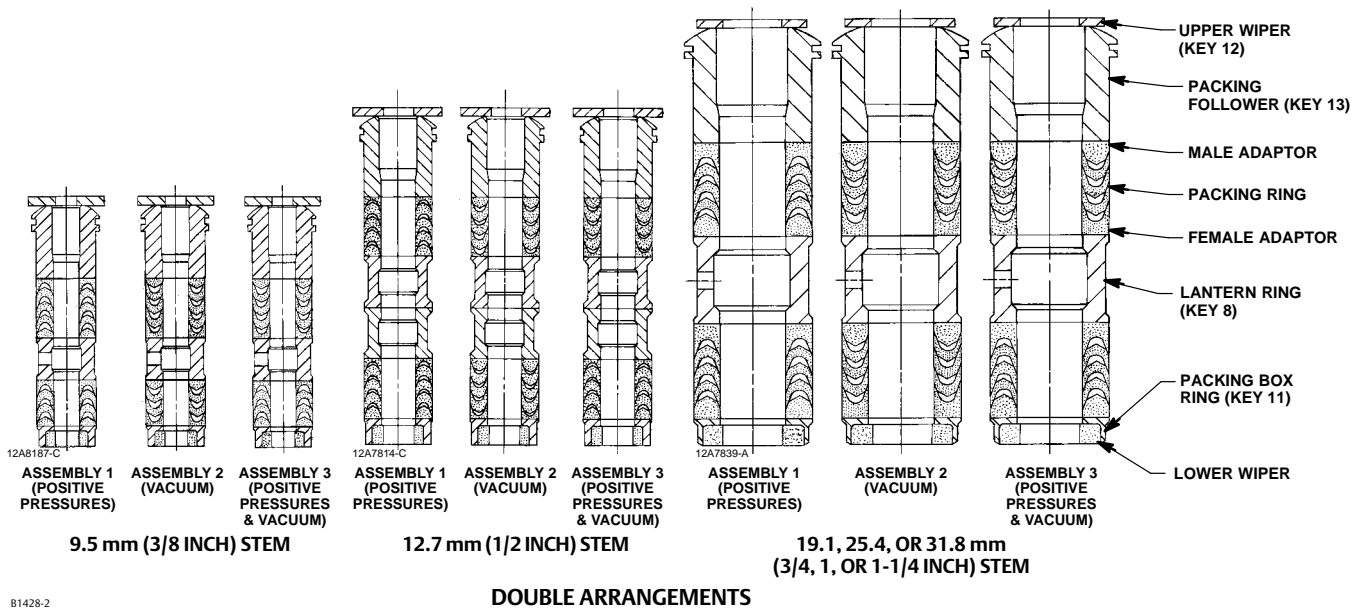

DOUBLE ARRANGEMENTS

B1428-2

Packing Maintenance

Note

For valves with ENVIRO-SEAL live-loaded packing, see the Fisher instruction manual, ENVIRO-SEAL Packing System for Sliding-Stem Valves, [D101642X012](#), for packing instructions. For valves with HIGH-SEAL live-loaded packing, see the Fisher instruction manual, HIGH-SEAL Live-Loaded Packing System, [D101453X012](#), for packing instructions.

Key numbers refer to figure 4 for PTFE V-ring packing and to figure 5 for PTFE/composition packing, unless otherwise indicated.

For spring-loaded single PTFE V-ring packing, the spring (key 8, figure 4) maintains a sealing force on the packing. If leakage is noted around the packing follower (key 13, figure 4), check to be sure the shoulder on the packing follower is touching the bonnet. If the shoulder is not touching the bonnet, tighten the packing flange nuts (key 5, figure 21) until the shoulder is against the bonnet. If leakage cannot be stopped in this manner, go to the Replacing Packing procedure.

Figure 5. Detail of PTFE/Composition Packing Arrangements

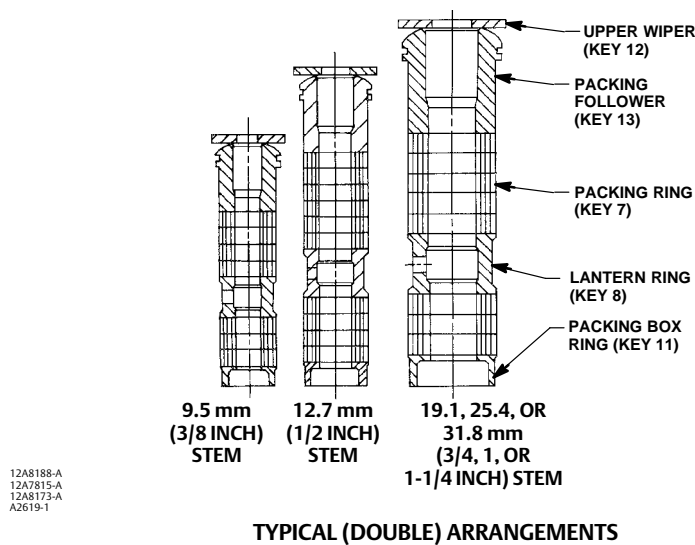

If there is undesirable packing leakage with other than spring-loaded packing, first try to limit the leakage and establish a stem seal by tightening the packing flange nuts.

If the packing is relatively new and tight on the stem and if tightening the packing flange nuts does not stop the leakage, the valve stem may be worn or nicked so that a seal cannot be made. The surface finish of a new valve stem is critical for making a good packing seal. If the leakage comes from the outside diameter of the packing, the leakage may be caused by nicks or scratches around the packing box wall. If performing any of the following procedures, inspect the valve stem and packing box wall for nicks and scratches.

Replacing Packing

⚠ WARNING

Avoid personal injury or property damage from sudden release of process pressure. Before performing any maintenance operations:

- Do not remove the actuator from the valve while the valve is still pressurized.
- Always wear protective gloves, clothing, and eyewear when performing any maintenance operations to avoid personal injury.
- Disconnect any operating lines providing air pressure, electric power, or a control signal to the actuator. Be sure the actuator cannot suddenly open or close the valve.
- Use bypass valves or completely shut off the process to isolate the valve from process pressure. Relieve process pressure on both sides of the valve. Drain the process media from both sides of the valve.
- Vent the pneumatic actuator loading pressure and relieve any actuator spring precompression.
- Use lock-out procedures to be sure that the above measures stay in effect while you work on the equipment.
- The valve packing box may contain process fluids that are pressurized, *even when the valve has been removed from the pipeline*. Process fluids may spray out under pressure when removing the packing hardware or packing rings, or when loosening the packing box pipe plug.
- Check with your process or safety engineer for any additional measures that must be taken to protect against process media.

1. Isolate the control valve from the line pressure, release pressure from both sides of the valve, and drain the process media from both sides of the valve. If using a power actuator, also shut-off all pressure lines to the power actuator and release all pressure from the actuator. Use lock-out procedures to be sure that the above measures stay in effect while you work on the equipment.
2. Disconnect the operating lines from the actuator and any leak-off piping from the bonnet. Disconnect the stem connector, and then remove the actuator from the valve by unscrewing the yoke locknut (key 15, figure 21) or the hex nuts (key 26, figure 21).
3. Loosen the packing flange nuts (key 5, figure 21) so that the packing is not tight on the valve stem. Remove any travel indicator parts and stem locknuts from the valve stem threads.

⚠ WARNING

To avoid personal injury or property damage caused by uncontrolled movement of the bonnet, loosen the bonnet by following the instructions in the next step. Do not remove a stuck bonnet by pulling on it with equipment that can stretch or store energy in any other manner. The sudden release of stored energy can cause uncontrolled movement of the bonnet.

Note

The following step also helps to provide additional assurance that the valve body fluid pressure has been relieved.

4. Hex nuts (key 16, figure 22, 23 or 24) attach the bonnet (key 1, figure 21) to the valve body (key 1, figure 22, 23 or 24). Loosen these nuts approximately 3 mm (1/8 inch). Then loosen the body-to-bonnet gasketed joint by either rocking the bonnet or prying between the bonnet and valve body. Work the prying tool around the bonnet until the bonnet loosens. If no fluid leaks from the joint, proceed with bonnet removal as described in the following steps.

CAUTION

To avoid damage to the seating surface caused by the valve plug and stem assembly dropping from the bonnet after being lifted part way out, temporarily install a valve stem locknut on the valve stem when lifting the bonnet. The locknut prevents the valve plug and stem assembly from dropping out of the bonnet.

5. Completely remove the hex nuts (key 16) and carefully lift the bonnet off the valve body.

6. Remove the locknut and separate the valve plug and stem from the bonnet. Set the parts on a protective surface to prevent damage to gasket or seating surfaces.
7. Remove the bonnet gasket (key 10, figure 22 through 24), and cover the opening in the valve body to protect the gasket surface and prevent foreign material from getting into the valve body cavity.
8. Remove the packing flange nuts, packing flange, upper wiper, and packing follower (keys 5, 3, 12, and 13, figure 21). Carefully push out all the remaining packing parts from the valve side of the bonnet using a rounded rod or other tool that will not scratch the packing box wall. Clean the packing box and the metal packing parts.
9. Inspect the valve stem threads and packing box surfaces for any sharp edges that might cut the packing. Scratches or burrs could cause packing box leakage or damage to the new packing. If the surface condition cannot be improved by light sanding, replace the damaged parts by following the appropriate steps in the Trim Maintenance procedure.
10. Remove the covering protecting the valve cavity and install a new bonnet gasket (key 10, figure 22 through 24), making sure the gasket seating surfaces are clean and smooth. Place the stem and valve plug into the valve body and slide the bonnet over the stem and onto the stud bolts (key 15, figure 22, 23, or 24).

Figure 6. Detail of Graphite Ribbon/Filament Packing

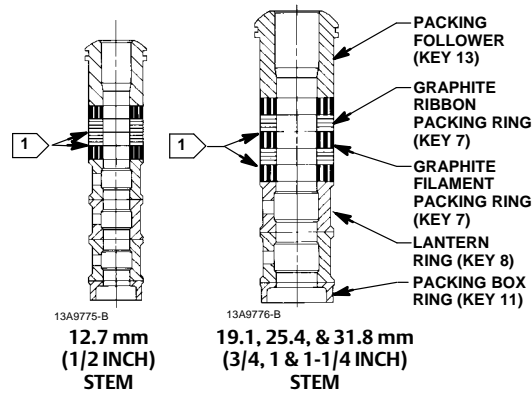

SINGLE ARRANGEMENTS

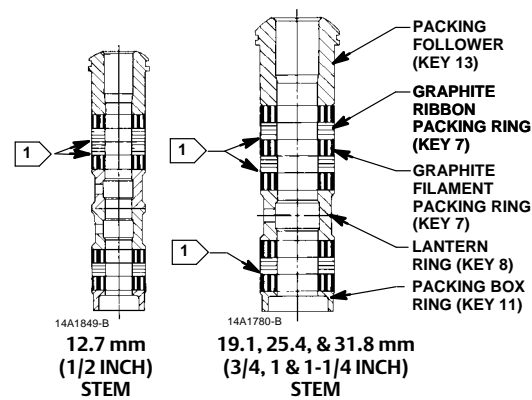

DOUBLE ARRANGEMENTS

A6067

NOTES:
 0.102 mm (0.004 INCH) THICK SACRIFICIAL ZINC WASHERS;
 USE ONLY ONE BELOW EACH GRAPHITE RIBBON RING.

Note

Proper performance of the tightening procedures in step 11 compresses the spiral wound gasket (key 12, figure 22 through 23) or load ring (key 26, figure 24) enough to both load and seal the seat ring gasket (key 13, figure 22, 23 or 24). It also compresses the outer edge of the bonnet gasket (key 10, figure 22 through 24) enough to seal the body-to-bonnet joint.

The proper bolting procedures in step 11 include--but are not limited to--ensuring that bolting threads are clean, and evenly tightening the nuts onto the studs in a criss-cross pattern. Because of the bolt-up characteristics of spiral wound gaskets, tightening one nut may loosen an adjacent nut. Repeat the criss-cross tightening pattern several times until each nut is tight and the body-to-bonnet seal is made.

Note

Stud(s) and nut(s) should be installed such that the manufacturer's trademark and material grade marking is visible, allowing easy comparison to the materials selected and documented in the Emerson/Fisher serial card provided with this product.

⚠ WARNING

Personal injury or damage to equipment could occur if improper stud and nut materials or parts are used. Do not operate or assemble this product with stud(s) and nut(s) that are not approved by Emerson/Fisher engineering and/or listed on the serial card provided with this product. Use of unapproved materials and parts could lead to stresses exceeding the design or code limits intended for this particular service. Install studs with the material grade and manufacturer's identification mark visible. Contact your Emerson Automation Solutions representative immediately if a discrepancy between actual parts and approved parts is suspected.

11. Lubricate the bolting (not necessary if factory pre-lubricated stud bolt nuts are used) and install it, using proper bolting procedures during tightening so that the body-to-bonnet joint will withstand test pressures and application service conditions. Use the bolt torques in table 5 as guidelines.
12. Install new packing and the metal packing box parts according to the appropriate arrangement in figure 4, 5, or 6. Place a smooth-edged pipe over the valve stem and gently tap each soft packing part into the packing box.
13. Slide the packing follower, upper wiper, and packing flange (keys 13, 12, and 3, figure 21) into position. Lubricate the packing flange studs (key 4, figure 21) and the faces of the packing flange nuts (key 5, figure 21). Install the packing flange nuts.
14. For spring-loaded PTFE V-ring packing, tighten the packing flange nuts until the shoulder on the packing follower (key 13, figure 21) contacts the bonnet.

For **graphite packing**, tighten the packing flange nuts to the maximum recommended torque shown in table 6. Then, loosen the packing flange nuts, and retighten them to the recommended minimum torque shown in table 6.

For **ENVIRO-SEAL or HIGH-SEAL live-loaded packing**, refer to the note at the beginning of the Packing Maintenance section.

For **other packing types**, tighten the packing flange nuts alternately in small equal increments until one of the nuts reaches the minimum recommended torque shown in table. Then, tighten the remaining flange nuts until the packing flange is level and at a 90-degree angle to the valve stem.

15. Mount the actuator on the valve assembly, and reconnect the actuator and valve stem according to the procedure in the appropriate actuator instruction manual.

Trim Maintenance

⚠ WARNING

Avoid personal injury or property damage from sudden release of process pressure. Before performing any maintenance operations:

- Do not remove the actuator from the valve while the valve is still pressurized.
- Always wear protective gloves, clothing, and eyewear when performing any maintenance operations to avoid personal injury.
- Disconnect any operating lines providing air pressure, electric power, or a control signal to the actuator. Be sure the actuator cannot suddenly open or close the valve.
- Use bypass valves or completely shut off the process to isolate the valve from process pressure. Relieve process pressure on both sides of the valve. Drain the process media from both sides of the valve.
- Vent the pneumatic actuator loading pressure and relieve any actuator spring precompression.
- Use lock-out procedures to be sure that the above measures stay in effect while you work on the equipment.
- The valve packing box may contain process fluids that are pressurized, *even when the valve has been removed from the pipeline*. Process fluids may spray out under pressure when removing the packing hardware or packing rings, or when loosening the packing box pipe plug.
- Check with your process or safety engineer for any additional measures that must be taken to protect against process media.

Table 5. Body-to-Bonnet Bolt Torque Guidelines

| VALVE SIZE, NPS | | BOLT TORQUES ^(1, 2) | |
|-----------------|----------------|--------------------------------|--------|
| | | N•m | Lbf•ft |
| 4x2 | | 102 | 75 |
| 6x4 or 8x4 | | 259 | 191 |
| 8x6 | CL300 or CL600 | 548 | 404 |
| | CL900 | 1315 | 970 |
| 10x8 | | 745 | 550 |
| 12x6 | | 548 | 404 |
| 12x8 | CL300 or CL600 | 732 | 540 |
| | CL900 | 2712 | 2000 |

1. Determined from laboratory tests.
2. For other materials, contact your [Emerson sales office](#) for torques.

Table 6. Recommended Torque for Packing Flange Nuts

| VALVE STEM DIAMETER | | PRESSURE RATING | GRAPHITE TYPE PACKING | | | | PTFE TYPE PACKING | | | |
|---------------------|-------|-----------------|-----------------------|--------|----------------|--------|-------------------|--------|----------------|--------|
| | | | Minimum Torque | | Maximum Torque | | Minimum Torque | | Maximum Torque | |
| | | | N•m | Lbf•In | N•m | Lbf•In | N•m | Lbf•In | N•m | Lbf•In |
| 12.7 | 1/2 | CL300 | 7 | 59 | 10 | 88 | 3 | 28 | 5 | 42 |
| 12.7 | | CL600 | 9 | 81 | 14 | 122 | 4 | 39 | 7 | 58 |
| 19.1 | 3/4 | CL300 | 15 | 133 | 23 | 199 | 7 | 64 | 11 | 95 |
| 19.1 | | CL600 | 21 | 182 | 31 | 274 | 10 | 87 | 15 | 131 |
| 25.4 | 1 | CL300 | 26 | 226 | 38 | 339 | 12 | 108 | 18 | 162 |
| 25.4 | | CL600 | 35 | 310 | 53 | 466 | 17 | 149 | 25 | 223 |
| 31.8 | 1-1/4 | CL300 | 36 | 318 | 54 | 477 | 17 | 152 | 26 | 228 |
| 31.8 | | CL600 | 49 | 437 | 74 | 655 | 24 | 209 | 36 | 314 |

CAUTION

In the following applicable procedures, to avoid damaging parts, do not grip the bellows shroud or other parts of the stem/bellows assembly. Grip only the flat areas on the stem where it extends out of the top of the bellows shroud.

For C-seal construction, see the appropriate C-seal sections in this instruction manual.

Except where indicated, key numbers in this section are referenced in figure 22 for EWD constructions, figure 22 for restricted trim detail, figure 23 for EWS constructions, and figure 24 for EWT constructions. Refer to figures 26 and 27 for Cavitol III, figure 27 for Whisper Trim III, and figure 29 for WhisperFlo construction.

Trim Removal

1. Remove the actuator and the bonnet according to steps 1 through 5 of the Replacing Packing procedure.

⚠ WARNING

Avoid personal injury or property damage from valve or packing leakage.

When lifting the valve plug stem (key 7) and attached valve plug (key 2) out of the valve, be certain that the cage (key 3) remains in the valve (key 1). This will prevent cage damage that might be caused by the cage dropping back into the valve after being lifted part way out.

Use care to avoid damaging gasket sealing surfaces.

Each graphite piston ring (key 6) in an EWD valve is brittle and in two pieces. Use care to avoid damage to the piston ring(s) caused by dropping or rough handling.

Any damage to the gasket sealing surfaces could cause the valve to leak. The surface finish of the valve stem (key 7) is critical for making a good packing seal. The inside surface of the cage or cage/baffle assembly (key 3) or cage retainer (key 31) is critical for smooth operation of the valve plug and for making a seal with the piston ring (key 6) or seal ring (key 28). The seating surfaces of the valve plug (key 2) and the seat ring (key 9) on a metal-seat construction are critical for tight shutoff. Protect these parts accordingly while disassembling the trim.

2. Remove the packing flange nuts, packing flange, upper wiper, and packing follower (keys 5, 3, 24, and 25, figure 21). Carefully push out all the remaining packing parts from the valve side of the bonnet using a rounded rod or other tool that will not scratch the packing box wall. Clean the packing box and the metal packing parts.
3. Inspect the valve stem threads and packing box surfaces for any sharp edges which might cut the packing. Scratches or burrs could cause packing box leakage or damage to the new packing. If the surface condition cannot be improved by light sanding, replace the damaged parts.
4. Remove the load ring (key 26) from an NPS 10x8 or 12x8 valve or the cage adaptor (key 4) from any restricted-trim valve through NPS 8x4, and wrap it for protection.
5. On a 102 mm (4-inch) travel valve with Whisper Trim I cage or on any NPS 8x6 or 12x6 valve with Whisper Trim III cage, remove the bonnet spacer (key 32) and bonnet gasket (key 10) on top of the spacer. Then on any construction with a cage retainer (key 31), remove the cage retainer and its associated gaskets. A Whisper Trim III cage retainer has two 3/8-inch - 16 UNC tappings in which screws or bolts can be installed for lifting.
6. Remove the cage or cage/baffle assembly (key 3) and the associated gaskets (keys 10, 11, and 12). With full-capacity constructions that have FGM gasket sets, a shim (key 53) is used instead of the cage gasket (key 11). If the cage is stuck in the valve, use a rubber mallet to strike the exposed portion of the cage at several points around its circumference.

Figure 7. TSO (Tight Shutoff Trim), Detail of Protected Soft Seat

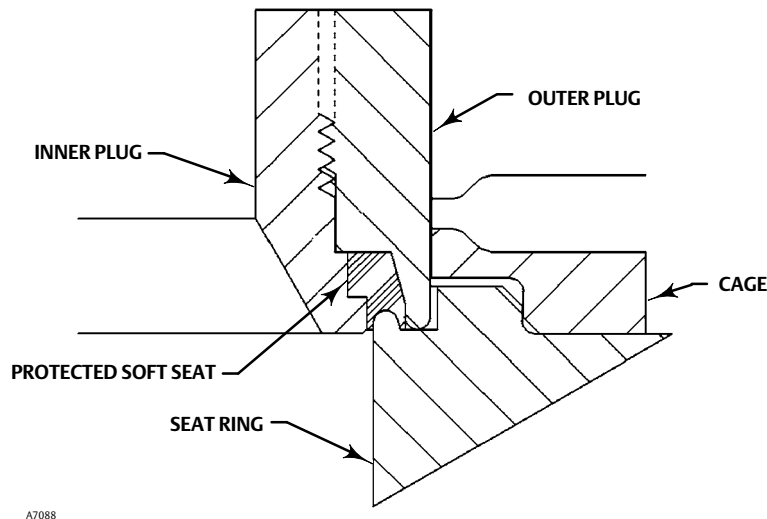

7. For constructions other than TSO (tight shutoff trim), remove the seat ring (key 9) or disk seat (key 22), seat ring gasket (key 13), and the seat ring adaptor (key 5) and adaptor gasket (key 14) where used in a restricted-capacity construction. EWS and EWT PTFE-seat constructions use a disk (key 23) sandwiched between the disk seat and disk retainer (key 21). A CL900 NPS 8x6 EWT construction with Cavitol III cage has its spiral wound gasket (key 12) on the side of the seat ring opposite the seat ring gasket.
8. For TSO (tight shutoff trim) constructions, perform the following steps (refer to figures 7 and 8):
 - Remove the piston ring, anti-extrusion rings, backup ring, and retainer.
 - Remove the set screws that lock the outer plug to the inner plug.
 - Using a strap wrench or similar tool, unscrew the outer plug from the inner plug. Do not damage the outer plug guide surfaces.
 - Remove the protected soft seat seal.
 - Inspect the parts for damage and replace if needed.
9. For all constructions, inspect parts for wear or damage that would prevent proper operation of the valve. Replace or repair trim parts according to the following procedures for lapping metal seats or other valve plug maintenance procedures, as appropriate.

Lapping Metal Seats

CAUTION

To avoid damaging the ENVIRO-SEAL bellows seal bonnet assembly, do not attempt to lap the metal seating surfaces. The design of the assembly prevents rotation of the stem and any forced rotation will damage internal components of the ENVIRO-SEAL bellows seal bonnet.

Figure 8. Typical Balanced TSO Trim

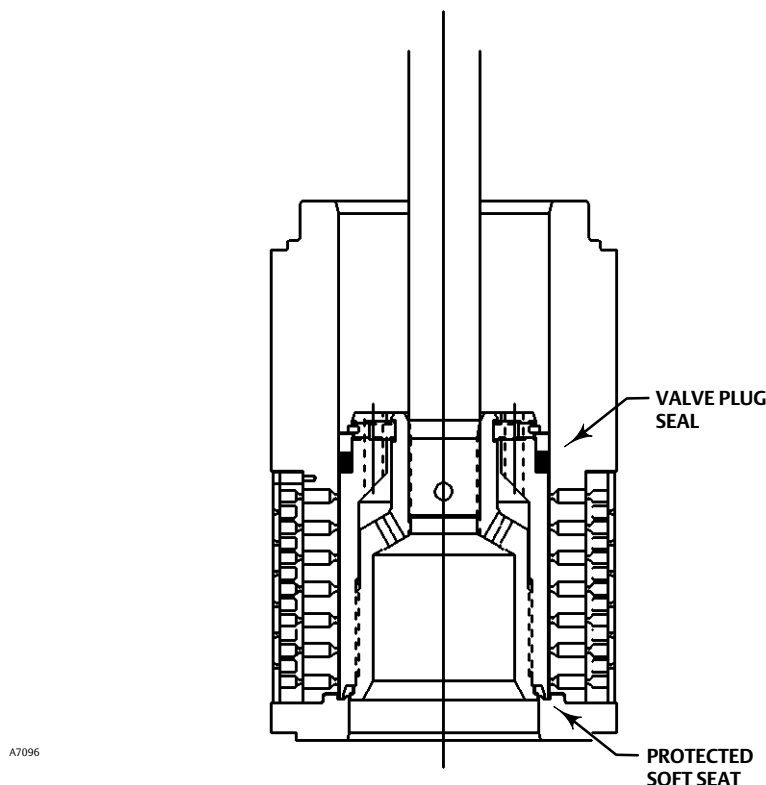

Except with respect to the ENVIRO-SEAL Bellows Seal Bonnet assembly, with metal seat constructions, seating surfaces of the valve plug and seat ring (keys 2 and 9, figures 24 through 26) can be lapped for improved shutoff. (Deep nicks should be machined out rather than ground out.) Use a good quality lapping compound of a mixture of 280 to 600-grit. Apply the compound to the bottom of the valve plug.

Assemble the valve to the extent that the cage (and cage retainer and bonnet spacer, if used) is in place and the bonnet is bolted to the valve. A simple handle can be made from a piece of strap iron locked to the valve plug stem with nuts. Rotate the handle alternately in each direction to lap the seats. After lapping, remove the bonnet, and clean the seat surfaces. Completely assemble the valve as described in the Trim Replacement portion of the Trim Maintenance section, and test the valve for shutoff. Repeat the lapping procedure if leakage is still excessive.

Valve Plug Maintenance

Except where indicated, key numbers in this section are referenced in figure 22 for EWD valve plugs, figure 23 for EWS valve plugs, and figure 24 for EWT valve plugs.

CAUTION

If replacing the piston ring (key 6) or seal ring (key 28), be careful not to scratch the surfaces of the ring groove in the valve plug or any of the surfaces of the replacement ring, or the replacement ring may not seal properly.

1. With the valve plug (key 2) removed, according to the Trim Removal section, proceed as appropriate:

For the EWD carbon-filled PTFE piston ring, the ring is split in one place. If there is visible damage, spread the ring slightly, and remove it from the groove in the valve plug. To install a carbon-filled PTFE piston ring, spread the ring apart slightly at the split, and install it over the stem and into the groove in the valve plug. The open side must face along the stem, depending on flow direction, as shown in figure 22.

For each EWD graphite piston ring, the ring can be easily removed since it is in two pieces. A new graphite piston ring is furnished as a complete ring. Use a vise with smooth or taped jaws to break this replacement ring into halves. Place the new ring in the vise so that the jaws will compress the ring into an oval. Slowly compress the ring until it snaps on both sides. If one side snaps first, do not try to tear or cut the other side. Instead, keep compressing the ring until the other side snaps. Be sure to match the broken ends when installing the ring in the valve plug groove.

For the EWT two-piece seal ring, the ring cannot be reused as it is a closed ring, which must be pried and/or cut from the groove. Then the elastomeric backup ring (key 29) can be spread slightly and removed.

To install a new two-piece seal ring, apply a general purpose silicone-base lubricant to both the backup ring and seal ring (keys 29 and 28). Place the backup ring over the stem (key 7) and into the groove. Place the seal ring over the top edge of the valve plug (key 2) so that it enters the groove on one side of the valve plug. Slowly and gently stretch the seal ring, and work it over the top edge of the valve plug. The PTFE material in the seal ring must be permitted time to cold-flow during the stretching procedure; so avoid jerking sharply on this ring. Stretching the seal ring over the valve plug may make it seem unduly loose when in the groove, but it will contract to its original size after insertion into the cage.

For the EWT spring-loaded seal ring, the ring used on a valve plug having a 136.5 mm (5.375 inch) or less port diameter may be removed undamaged by first working the retaining ring (key 27) off with a screwdriver. Then carefully slide the metal backup ring (key 29) and seal ring (key 28) off the valve plug (key 2). The spring-loaded seal ring used on a valve plug having a 178 mm (7-inch) or greater port diameter must be carefully pried and/or cut from its groove. Therefore, it cannot be reused.

A spring-loaded seal ring must be installed so that its open side faces toward either the top or the bottom of the valve plug, depending on flow direction, as shown in view A of figure 24. To install a spring-loaded seal ring on a valve plug with a 136.5 mm (5.375 inch) or less port diameter, slide the seal ring (key 28) onto the valve plug followed by the metal backup ring (key 29). Then install the retaining ring (key 27) by inserting one end in the groove and, while turning the plug, press the ring into the groove. Again, be careful not to scratch any surfaces of the ring or plug.

To install the seal ring on a valve plug with 178 mm (7-inch) or greater port diameter, lubricate it with a general purpose silicone-base lubricant. Then gently stretch the seal ring, and work it over the top edge of the valve plug. The PTFE material in the seal ring must be permitted time to cold-flow during the stretching procedure; so avoid jerking sharply on the ring. Stretching the seal ring over the valve plug may make it seem unduly loose when in the groove, but it will contract to its original size after insertion into the cage.

CAUTION

Never reuse an old stem or adaptor with a new valve plug. Using an old stem or adaptor with a new plug requires drilling a new pin hole in the stem (or adaptor in case an ENVIRO-SEAL bellows seal bonnet is being used). This drilling weakens the stem or adaptor and may cause failure in service. However, a used valve plug may be reused with a new stem or adaptor except with Cavitrol III trim.

Note

The valve plug and valve plug stem for Cavitrol III trim are a matched set and must be ordered together. If the Cavitrol III valve plug or valve plug stem is damaged, replace the entire assembly (key 2, figure 26 and 27).

2. To replace the valve stem (key 7), drive out the pin (key 8). Unscrew the valve plug from the stem or adaptor.
3. To replace the adaptor (key 24, figure 21) on ENVIRO-SEAL bellows seal bonnets, place the plug stem assembly and valve plug in a soft-jaw chuck or other type of vise so that the jaws grip a portion of the valve plug that is not a seating surface. Drive out the pin (key 36, figure 21). Reverse the plug stem assembly and valve plug in the soft-jaw chuck or vise. Grip the flat areas on the valve stem just below the threads for the actuator/stem connection. Unscrew the valve plug/adaptor assembly (key 24, figure 21) from the valve stem assembly (key 20, figure 21).
4. Screw the new stem or adaptor into the valve plug. Tighten to the torque value given in table 7. Refer to table 7 to select the proper drill size. Drill through the stem or adaptor, using the hole in the valve plug as a guide. Remove any chips or burrs, and drive in a new pin to lock the assembly.
5. For ENVIRO-SEAL bellows seal bonnets, grip the flats of the stem extending out of the top of the bellows shroud with a soft-jaw chuck or other type of vise. Screw the valve plug/adaptor assembly onto the valve stem. Tighten as necessary to align the pin hole in the stem with one of the holes in the adaptor. Secure the adaptor to the stem with a new pin.

Trim Replacement

Except where indicated, key numbers in this section are referenced in figure 22 for EWD constructions, figure 22 for restricted trim detail, figure 23 for EWS construction, and figure 24 for EWT constructions. Refer to figures 26 and 27 for Cavitrol III, figure 28 for Whisper Trim III, and figure 29 for WhisperFlo constructions.

1. With a restricted-trim seat ring construction, install the adaptor gasket (key 14) and seat ring adaptor (key 5).
2. Install the seat-ring gasket (key 13), seat ring (key 9), or disk seat (key 22). With a PTFE-seat construction install the disk and disk retainer (keys 21 and 23). With an NPS 8x6 CL900 EWT valve with Cavitrol III cage, install the spiral wound gasket (key 12) on the seat ring.
3. Install the cage or cage/baffle assembly (key 3). Any rotational orientation of the cage or assembly with respect to the valve is acceptable. A Whisper Trim III cage designated by level A3, B3, or C3 may be installed with either end up. The level D3 cage/baffle assembly or Cavitrol III cage assembly, however, must be installed with the hole pattern end next to the seat ring. If a cage retainer (key 31) is to be used, place it on top of the cage.
4. For constructions other than TSO (tight shutoff trim), slide the valve plug (key 2) and stem assembly or valve plug and ENVIRO-SEAL bellows seal assembly into the cage. Make sure the piston ring or seal ring (key 6 or 28) is evenly engaged in the entrance chamfer at the top of the cage (key 3) or cage retainer (key 31) to avoid damaging the ring.
5. For TSO (tight shutoff) trim constructions, perform the following steps (refer to figures 7 and 8).
 - Thread the outer plug onto the inner plug until the parts seat metal to metal, using a strap wrench or similar tool that will not damage the outer plug guide surfaces.
 - Mark the top of the inner plug and outer plug with alignment marks in the assembled position.

Table 7. Valve Stem to Plug Torque and Pin Replacement Data

| VALVE STEM DIAMETER | | STEM TORQUE, MINIMUM TO MAXIMUM | | DRILL SIZE, INCHES |
|---------------------|-------|---------------------------------|------------|--------------------|
| mm | Inch | N•m | Lbf•ft | |
| 12.7 | 1/2 | 81 to 115 | 60 to 85 | 1/8 |
| 19.1 | 3/4 | 237 to 339 | 175 to 250 | 3/16 |
| 25.4 | 1 | 420 to 481 | 310 to 355 | 1/4 |
| 31.8 | 1-1/4 | 827 to 908 | 610 to 670 | 1/4 |

- Disassemble the outer plug from the inner plug and install the seal over the inner plug, so that the seal rests below the threaded area.
- Thread the outer plug onto the inner plug and tighten with a strap wrench or similar tool until the alignment marks line up. This will ensure that the plug parts are metal to metal and the seal is compressed properly. Do not damage the outer plug guide surfaces.

- Install set screws centering the inner plug in the outer plug and torque to 11 N•m (8 lbf•ft).
 - Assemble the piston ring, anti-extrusion rings, backup ring, and retainer.
6. For all constructions, place the gaskets (keys 12, 11 or 14 if used, and 10) and the shim, if used (key 53), on top of the cage or cage retainer. If there is a cage adaptor (key 4) or a bonnet spacer (key 32), set it on the cage or cage retainer gaskets and place another flat sheet gasket (key 10) on top of the adapter or spacer. If there is only a cage retainer or bonnet spacer, place another flat sheet gasket on the retainer or spacer.
 7. With an NPS 10x8 or 12x8 valve, install the load ring (key 26).
 8. Mount the bonnet on the valve, and complete assembly according to steps 11 through 15 of the Replacing Packing section. Be sure to observe the note prior to step 11.

Retrofit: Installing C-seal Trim

Note

Additional actuator thrust is required for a valve with C-seal trim. When installing C-seal trim in an existing valve, contact your [Emerson sales office](#) for assistance in determining new actuator thrust requirements.

Assemble the new valve plug/retainer assembly (with C-seal plug seal) using the following instructions:

CAUTION

To avoid leakage when the valve is returned to service, use appropriate methods and materials to protect all sealing surfaces of the new trim parts while assembling the individual parts and during installation in the valve body.

1. Apply a suitable high-temperature lubricant to the inside diameter of the C-seal plug seal. Also, lubricate the outside diameter of the valve plug where the C-seal plug seal must be pressed into the proper sealing position (figure 9).
2. Orient the C-seal plug seal for correct sealing action based on the process fluid flow direction through the valve.
 - The open interior of the C-seal plug seal must face up in a valve with flow-up construction (figure 9).
 - The open interior of the C-seal plug seal must face down in a valve with flow-down construction (figure 9).

Note

An installation tool must be used to properly position the C-seal plug seal on the valve plug. A tool is available as a spare part from Emerson or a tool could be manufactured following the dimensions given in figure 10.

3. Place the C-seal plug seal over the top of the valve plug and press the C-seal plug seal onto the plug using the C-seal installation tool. Carefully press the C-seal plug seal onto the plug until the installation tool contacts the horizontal reference surface of the valve plug (figure 11).
4. Apply a suitable high-temperature lubricant to the threads on the plug. Then, place the C-seal retainer onto the plug and tighten the retainer using an appropriate tool such as a strap wrench.

- Using an appropriate tool such as a center punch, stake the threads on top of the plug in one place (figure 12) to secure the C-seal retainer.

Figure 9. Fisher EWD with C-seal Trim

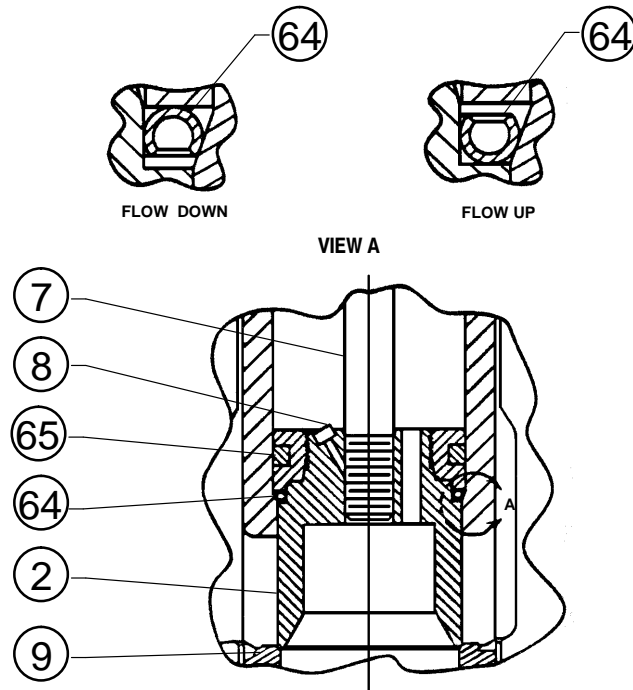

A6790

- Install the new plug/retainer assembly with C-seal plug seal on the new stem following the appropriate instructions in the Trim Replacement section of this manual.
- Install piston rings by following instructions in the Trim Replacement section of this manual.
- Remove the existing valve actuator and bonnet following the appropriate instructions in the Replacing Packing section in this manual.

CAUTION

Do not remove the existing valve stem from the valve plug unless you are planning to replace the valve stem.

Never reuse an old valve stem with a new plug or reinstall a valve stem after it has been removed. Replacing a valve stem requires drilling a new pin hole in the stem. This drilling weakens the stem and may cause failure in service. However, a used valve plug may be reused with a new valve stem.

- Remove the existing valve stem and plug, cage, and seat ring from the valve body following the appropriate instructions in the Trim Removal section in this manual.
- Replace all gaskets according to appropriate instructions in the Trim Replacement section in this manual.
- Install the new seat ring, cage, valve plug/retainer assembly, and stem into the valve body and completely reassemble the valve package following the appropriate instructions in the Trim Replacement section in this manual.

| FOR VALVE PLUGS FITTING PORT SIZE (Inches) | DIMENSIONS, mm (See Drawing Below) | | | | | | | | Part Number (To Order A Tool) |
|--|---|-------------------|---------------|---------------|--------|-------------------|-------------------|-------------------|----------------------------------|
| | A | B | C | D | E | F | G | H | |
| 2.875 | 82.55 | 52.324 - 52.578 | 4.978 - 5.029 | 3.708 - 3.759 | 41.148 | 52.680 - 52.781 | 55.118 - 55.626 | 70.891 - 71.044 | 24B9816X012 |
| 3.4375 | 101.6 | 58.674 - 58.928 | 4.978 - 5.029 | 3.708 - 3.759 | 50.8 | 61.011 - 61.112 | 63.449 - 63.957 | 85.166 - 85.319 | 24B5612X012 |
| 3.625 | 104.394 | 65.024 - 65.278 | 4.978 - 5.029 | 3.708 - 3.759 | 50.8 | 68.936 - 69.037 | 71.374 - 71.882 | 89.941 - 90.094 | 24B3630X012 |
| 4.375 | 125.984 | 83.439 - 83.693 | 4.978 - 5.029 | 3.708 - 3.759 | 50.8 | 87.351 - 87.452 | 89.789 - 90.297 | 108.991 - 109.144 | 24B3635X012 |
| 5.375 | 142.748 | 100.076 - 100.33 | 4.978 - 5.029 | 3.708 - 3.759 | 45.974 | 103.835 - 103.937 | 106.274 - 106.782 | 128.219 - 128.372 | 23B9193X012 |
| 7 | 184.15 | 141.376 - 141.630 | 4.978 - 5.029 | 3.708 - 3.759 | 60.198 | 145.136 - 145.237 | 147.574 - 148.082 | 169.520 - 169.672 | 23B9180X012 |
| 8 | 209.55 | 166.776 - 167.030 | 4.978 - 5.029 | 3.708 - 3.759 | 55.88 | 170.536 - 170.637 | 172.974 - 173.482 | 194.920 - 195.072 | 24B9856X012 |
| FOR VALVE PLUGS FITTING PORT SIZE (Inches) | DIMENSIONS, INCHES (See Drawing Below) | | | | | | | | Part Number (To Order A Tool) |
| | A | B | C | D | E | F | G | H | |
| 2.875 | 3.25 | 2.060 - 2.070 | 0.196 - 0.198 | 0.146 - 0.148 | 1.62 | 2.074 - 2.078 | 2.170 - 2.190 | 2.791 - 2.797 | 24B9816X012 |
| 3.4375 | 4.00 | 2.310 - 2.320 | 0.196 - 0.198 | 0.146 - 0.148 | 2.00 | 2.402 - 2.406 | 2.498 - 2.518 | 3.353 - 3.359 | 24B5612X012 |
| 3.625 | 4.11 | 2.560 - 2.570 | 0.196 - 0.198 | 0.146 - 0.148 | 2.00 | 2.714 - 2.718 | 2.810 - 2.830 | 3.541 - 3.547 | 24B3630X012 |
| 4.375 | 4.96 | 3.285 - 3.295 | 0.196 - 0.198 | 0.146 - 0.148 | 2.00 | 3.439 - 3.443 | 3.535 - 3.555 | 4.291 - 4.297 | 24B3635X012 |
| 5.375 | 5.62 | 3.940 - 3.950 | 0.196 - 0.198 | 0.146 - 0.148 | 1.81 | 4.088 - 4.092 | 4.184 - 4.204 | 5.048 - 5.054 | 23B9193X012 |
| 7 | 7.25 | 5.566 - 5.576 | 0.196 - 0.198 | 0.146 - 0.148 | 2.37 | 5.714 - 5.718 | 5.810 - 5.830 | 6.674 - 6.680 | 23B9180X012 |
| 8 | 8.25 | 6.566 - 6.576 | 0.196 - 0.198 | 0.146 - 0.148 | 2.20 | 6.714 - 6.718 | 6.810 - 6.830 | 7.674 - 7.680 | 24B9856X012 |

Figure 10. C-seal Plug Seal Installation Tool

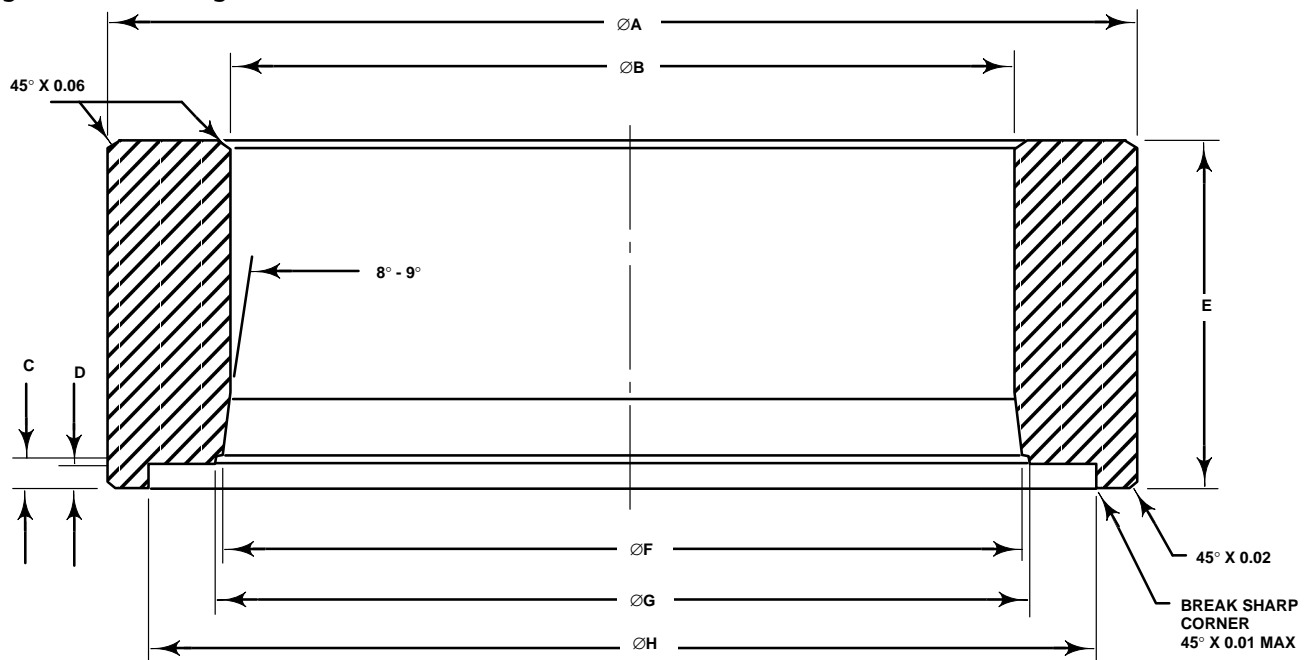

A6777

Figure 11. Installing the C-seal Plug Seal Using the Installation Tool

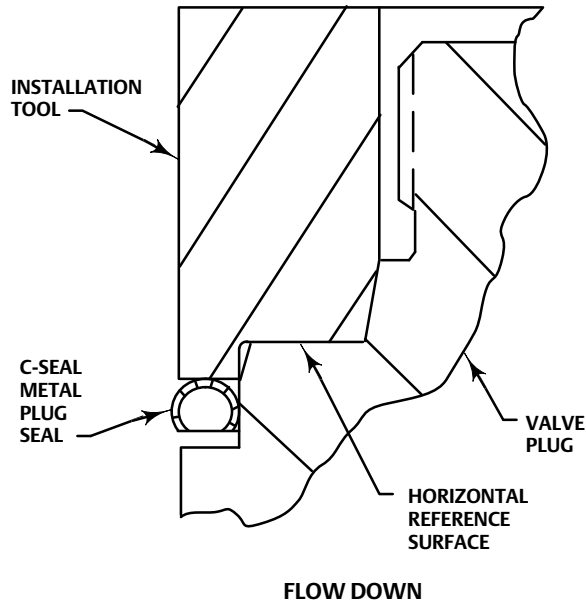

NOTE:
PRESS INSTALLATION TOOL OVER VALVE PLUG UNTIL THE TOOL CONTACTS THE
HORIZONTAL REFERENCE SURFACE OF THE VALVE PLUG.

A6778

Figure 12. Stake the Threads of the C-seal Retainer

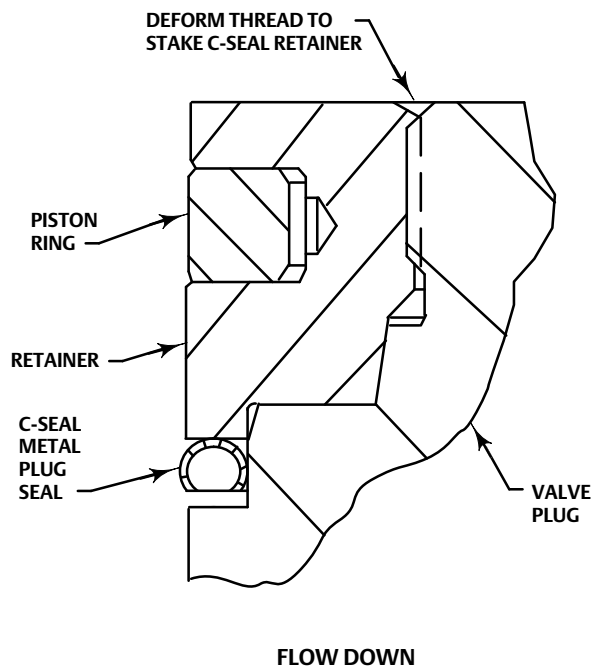

A6779

CAUTION

To avoid excessive leakage and seat erosion, the valve plug must be initially seated with sufficient force to overcome the resistance of the C-seal plug seal and contact the seat ring. You can correctly seat the valve plug by applying the full actuator load. This force will adequately drive the valve plug to the seat ring, thus giving the C-seal plug seal a predetermined permanent set. Once this is done, the plug/retainer assembly, the cage, and the seat ring become a matched set.

With full actuator force applied and the valve plug fully seated, align the actuator travel indicator scale with the lower end of valve travel. Refer to the appropriate actuator instruction manual for information on this procedure.

Replacement of Installed C-seal Trim

Trim Removal (C-seal Constructions)

1. Remove the valve actuator and bonnet following the appropriate instructions in the Replacing Packing section in this manual.

CAUTION

To avoid leakage when the valve is returned to service, use appropriate methods and materials to protect all sealing surfaces of the trim parts during maintenance.

Use caution when removing piston ring(s) and C-seal plug seal to avoid scratching any sealing surface.

CAUTION

Do not remove the valve stem from the plug/retainer assembly unless you are planning to replace the valve stem.

Never reuse an old valve stem with a new plug or reinstall a valve stem after it has been removed. Replacing a valve stem requires drilling a new pin hole in the stem. This drilling weakens the stem and may cause failure in service. However, a used valve plug may be reused with a new valve stem.

2. Remove the plug/retainer assembly (with C-seal plug seal), cage, and seat ring from the valve body following the appropriate instructions in the Trim Removal section of this manual.
3. Locate the staked thread on top of the valve plug (figure 12). The staked thread secures the retainer. Use a drill with a 1/8 inch bit to drill out the staked area of the thread. Drill approximately 1/8 inch into the metal to remove the staking.
4. Locate the break between sections of the piston ring(s). Using an appropriate tool such as a flat-blade screwdriver, carefully pry out the piston ring(s) from the groove(s) in the C-seal retainer.
5. After removing the piston ring(s), locate the 1/4-inch diameter hole in the groove. In a retainer with two piston ring grooves, the hole will be found in the upper groove.
6. Select an appropriate tool such as a punch and place the tip of the tool into the hole with the body of the tool held tangent to the outside diameter of the retainer. Strike the tool with a hammer to rotate the retainer and free it from the valve plug. Remove the retainer from the plug.
7. Use an appropriate tool such as a flat-blade screwdriver to pry the C-seal plug seal off the plug. Use caution to avoid scratches or other damage to the sealing surfaces where the C-seal plug seal makes contact with the valve plug (figure 13).

Figure 13. Lower (Valve Plug to Seat Ring) and Upper (C-seal Plug Seal to Cage) Seating Surfaces

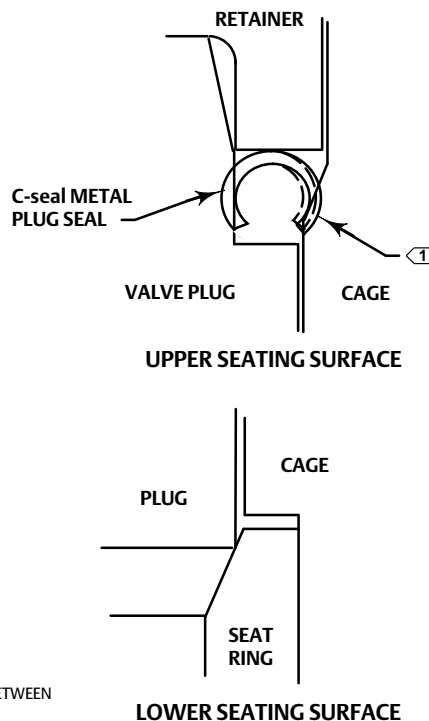

NOTE:
 1 > UPPER SEATING SURFACE IS THE AREA OF CONTACT BETWEEN THE C-seal METAL PLUG SEAL AND THE CAGE.

A6780

8. Inspect the lower seating surface where the valve plug contacts the seat ring for wear or damage which would prevent proper operation of the valve. Also, inspect the upper seating surface inside the cage where the C-seal plug seal contacts the cage, and inspect the sealing surface where the C-seal plug seal makes contact with the plug (figure 13).
9. Replace or repair trim parts according to the following procedure for lapping metal seats, remachining metal seats, or other valve plug maintenance procedures as appropriate.

Lapping Metal Seats (C-seal Constructions)

Before installing a new C-seal plug seal, lap the lower seating surface (valve plug to seat ring, figure 13) following appropriate procedures in the Lapping Metal Seats section of this manual.

Remachining Metal Seats (C-seal Constructions)

See figure 14. A valve plug with a C-seal metal plug seal features two seating surfaces. One seating surface is found where the valve plug contacts the seat ring. The second seating surface is found where the C-seal plug seal contacts the upper seating surface in the cage. If you machine the seats on the seat ring and/or plug, you must machine an equal dimension from the seating area in the cage.

CAUTION

If metal is removed from the seat ring and plug and a corresponding amount is not removed from the cage seating area, the C-seal plug seal will be crushed as the valve closes and the C-seal retainer will strike the seating area of the cage, preventing the valve from closing.

Figure 14. Example of Machining the Lower (Valve Plug to Seat Ring) and Upper (C-seal Plug Seal to Cage) Seating Surfaces

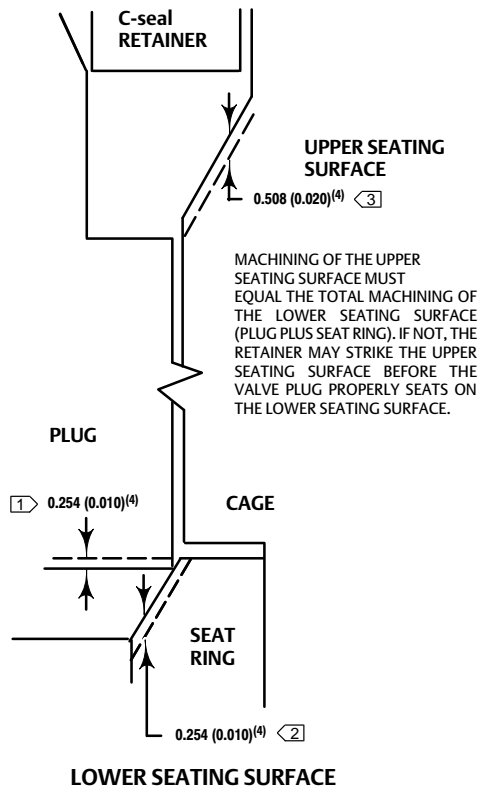

NOTE:

PLUS

1. REMOVAL OF 0.254 mm (0.010 inch) FROM THE VALVE PLUG

2. REMOVAL OF 0.254 mm (0.010 inch) FROM THE SEAT RING

3. REMOVAL OF 0.508 mm (0.020 inch) FROM THE UPPER SEATING SURFACE IN THE CAGE

4. THESE VALUES ARE FOR EXAMPLE ONLY. REMOVE ONLY THE MINIMUM AMOUNT OF MATERIAL REQUIRED TO REFURBISH THE SEATS.

A6781 / IL

Trim Replacement (C-seal Constructions)

1. Apply a suitable high-temperature lubricant to the inside diameter of the C-seal plug seal. Also, lubricate the outside diameter of the valve plug where the C-seal plug seal must be pressed into the proper sealing position (figure 9).
2. Orient the C-seal plug seal for correct sealing action based on the process fluid flow direction through the valve.
 - The open interior of the C-seal plug seal must face up in a valve with flow-up construction (figure 9).
 - The open interior of the C-seal plug seal must face down in a valve with flow-down construction (figure 9).

Note

An installation tool must be used to properly position the C-seal plug seal on the valve plug. A tool is available as a spare part from Emerson or a tool could be manufactured following the dimensions given in figure 10.

3. Place the C-seal plug seal over the top of the valve plug and press it onto the plug using the installation tool. Carefully press the C-seal plug seal onto the plug until the installation tool contacts the horizontal reference surface of the valve plug (figure 11).
4. Apply a suitable high-temperature lubricant to the threads on the plug. Then, place the C-seal retainer onto the plug and tighten the retainer using an appropriate tool such as a strap wrench.
5. Using an appropriate tool such as a center punch, stake the threads on top of the plug in one place (figure 12) to secure the C-seal retainer.
6. Replace the piston ring(s) following instructions in the Trim Replacement section of this manual.
7. Return the seat ring, cage, plug/retainer assembly, and stem to the valve body and completely reassemble the valve package following the appropriate instructions in the Trim Replacement section of this manual.

CAUTION

To avoid excessive leakage and seat erosion, the valve plug must be initially seated with sufficient force to overcome the resistance of the C-seal plug seal and contact the seat ring. You can correctly seat the valve plug by applying the full actuator load. This force will adequately drive the valve plug to the seat ring, thus giving the C-seal plug seal a predetermined permanent set. Once this is done, the plug/retainer assembly, the cage, and the seat ring become a matched set.

With full actuator force applied and the valve plug fully seated, align the actuator travel indicator scale with the lower end of valve travel. Refer to the appropriate actuator instruction manual for information on this procedure.

ENVIRO-SEAL Bellows Seal Bonnet

Replacing a Plain or Extension Bonnet with an ENVIRO-SEAL Bellows Seal Bonnet (Stem/Bellows Assembly)

Except where indicated, key numbers in this section are referenced in figure 22 for EWD constructions, figure 22 for restricted trim detail, figure 23 for EWS constructions, and figure 24 for EWT constructions. Refer to figures 26 and 27 for Cavitrol III, figure 27 for Whisper Trim III, and figure 29 for WhisperFlo constructions.

Table 8. Recommended Torque for ENVIRO-SEAL Bellows Seal Bonnet Packing Flange Nuts

| VALVE SIZE, NPS | VALVE STEM DIAMETER THROUGH PACKING | MINIMUM TORQUE | | MAXIMUM TORQUE | |
|--------------------|---|----------------|--------|----------------|--------|
| | | N•m | Lbf•in | N•m | Lbf•in |
| 4x2 | 1/2 | 2 | 22 | 4 | 33 |
| 6x4 to 12x8 | 1 | 5 | 44 | 8 | 67 |

1. Remove the actuator and bonnet according to steps 1 through 6 of the Replacing Packing procedure in the Maintenance section.
2. Lift out the cage.
3. Remove and discard the existing bonnet gasket. Cover the valve body opening to protect sealing surfaces and to prevent foreign material from entering the valve body cavity.

Note

The ENVIRO-SEAL stem/bellows assembly for easy-e™ valves is available only with a threaded and drilled plug/adaptor/stem connection. The existing valve plug can be reused with the new stem/bellows assembly or a new plug can be installed.

4. Inspect the existing valve plug. If the plug is in good condition, it can be reused with the new ENVIRO-SEAL stem/bellows assembly. To remove the existing valve plug from the stem, first, place the existing plug stem assembly in a soft-jaw chuck or other type of vise so that the jaws grip a portion of the valve plug that is not a seating surface. Drive out or drill out the pin (key 8).
5. Then, reverse the plug stem assembly in the soft-jaw chuck or vise. Grip the valve stem in an appropriate place and unscrew the existing plug from the valve stem.

CAUTION

When installing a valve plug on the ENVIRO-SEAL stem/bellows assembly, the valve stem must not be rotated. Damage to the bellows may result.

Do not grip the bellows shroud or other parts of the stem/bellows assembly. Grip only the flat areas on the stem where it extends out of the top of the bellows shroud.

Note

The ENVIRO-SEAL stem/bellows assembly has a one-piece stem.

6. To attach the valve plug to the stem of the new ENVIRO-SEAL stem/bellows assembly, it is necessary to first attach the plug to the adaptor (key 24, figure 21). Locate the adaptor. Notice that a hole has not been drilled in the threads where the plug screws onto the adaptor. Secure the valve plug in a soft-jaw chuck or other type of vise. Do not grip the plug on any seating surface. Position the plug in the chuck or vise for easy threading of the adaptor. Thread the adaptor into the valve plug and tighten to the appropriate torque value.
7. Select the proper size of drill bit and drill through the adaptor using the hole in the valve plug as a guide. Remove any metal chips or burrs and drive in a new pin (key 8) to lock the plug/adaptor assembly together.
8. Attach the plug/adaptor assembly to the ENVIRO-SEAL stem/bellows assembly by first securing the stem/bellows assembly in a soft-jaw chuck or other type of vise so that the jaws of the chuck or vise grip the flats of the stem extending out of the top of the bellows shroud. Screw the valve plug/adaptor assembly onto the valve stem. Tighten the plug/adaptor assembly until it is snug. Then turn the plug/adaptor assembly to the next pin hole in the valve stem. Drive in new pin (key 36, figure 21) to lock the assembly.
9. Inspect the seat ring (key 9). Replace, if necessary.
10. Place a new gasket (key 10) into the valve body in place of the bonnet gasket. Install the new stem/bellows assembly with valve plug/adaptor by placing it into the valve body on top of the new bellows gasket.
11. Place a new gasket (key 22, figure 21) over the stem/bellows assembly. Place the new ENVIRO-SEAL bonnet over the stem/bellows assembly.

Figure 15. PTFE Packing Arrangement for Use in Fisher ENVIRO-SEAL Bellows Seal Bonnets

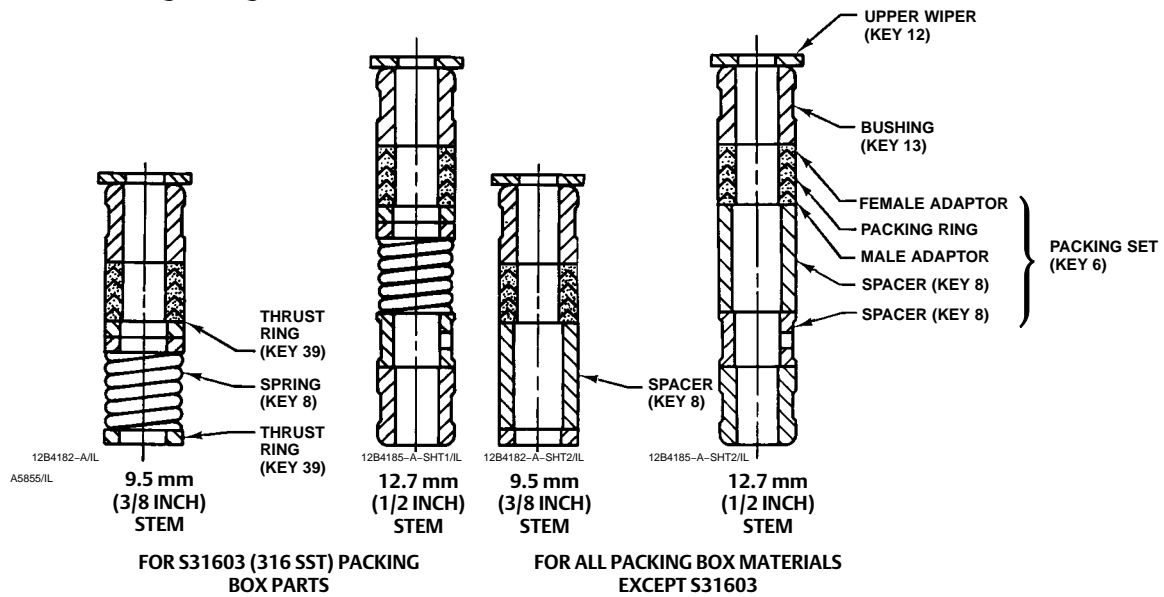

SINGLE ARRANGEMENTS

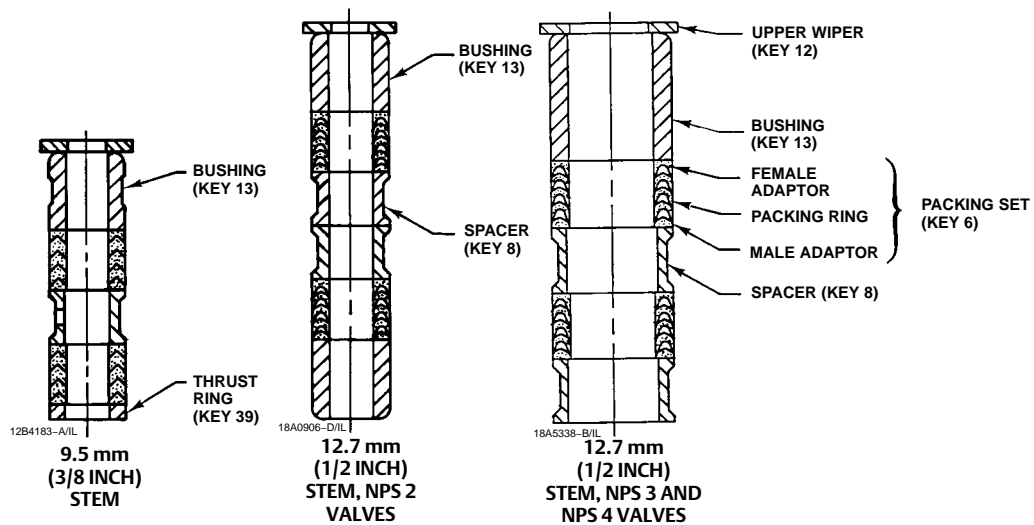

DOUBLE ARRANGEMENTS

A5886-1

Note

Stud(s) and nut(s) should be installed such that the manufacturer's trademark and material grade marking is visible, allowing easy comparison to the materials selected and documented in the Emerson/Fisher serial card provided with this product.

⚠ WARNING

Personal injury or damage to equipment could occur if improper stud and nut materials or parts are used. Do not operate or assemble this product with stud(s) and nut(s) that are not approved by Emerson/Fisher engineering and/or listed on the serial card provided with this product. Use of unapproved materials and parts could lead to stresses exceeding the design or code limits intended for this particular service. Install studs with the material grade and manufacturer's identification mark visible. Contact your Emerson representative immediately if a discrepancy between actual parts and approved parts is suspected.

12. Properly lubricate the bonnet stud bolts. Install and tighten the bonnet hex nuts to the proper torque.
13. Install the new packing and the metal packing box parts according to the appropriate arrangement in figure 15 or 16.
14. Install the packing flange. Properly lubricate the packing flange stud bolts and the faces of the packing flange nuts.

Figure 16. Double Graphite Ribbon/Filament Arrangements for Use in Fisher ENVIRO-SEAL Bellows Seal Bonnets

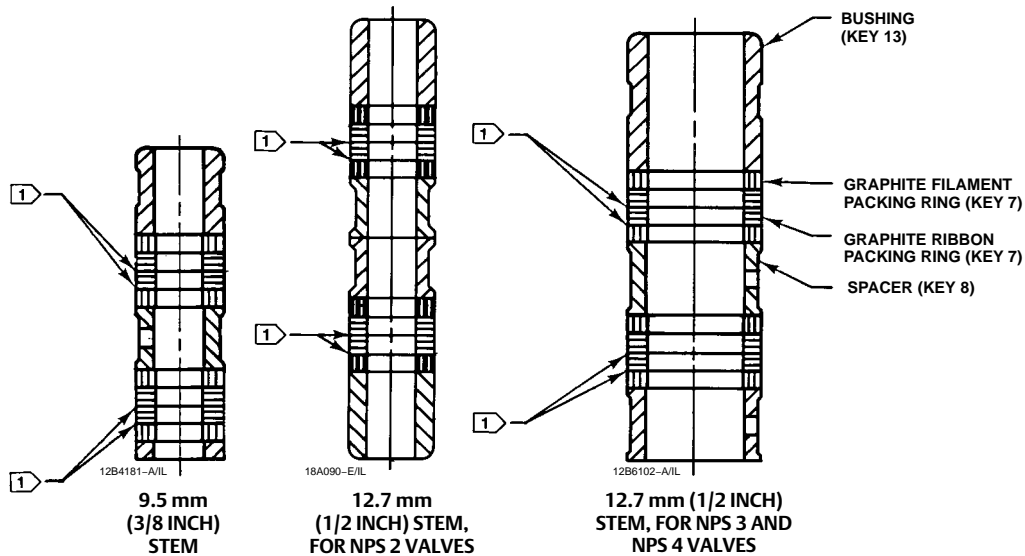

NOTE:
 0.102 mm (0.004 INCH) THICK SACRIFICIAL ZINC WASHERS; USE ONLY ONE BELOW EACH GRAPHITE RIBBON RING.

For **graphite packing**, tighten the packing flange nuts to the maximum recommended torque shown in table 8. Then, loosen the packing flange nuts, and retighten them to the recommended minimum torque shown in table 8.

For **other packing types**, tighten the packing flange nuts alternately in small equal increments until one of the nuts reaches the minimum recommended torque shown in table 8. Then, tighten the remaining flange nut until the packing flange is level and at a 90-degree angle to the valve stem.

15. Install the travel indicator parts and stem locknuts; mount the actuator on the valve body according to the procedure in the appropriate actuator instruction manual.

Replacement of an Installed ENVIRO-SEAL Bellows Seal Bonnet (Stem/Bellows Assembly)

1. Remove the actuator and bonnet according to steps 1 through 6 of the Replacing Packing procedure of the Maintenance section.
2. Lift out the cage. Remove and discard the existing bonnet gasket and bellows gasket. Cover the valve body opening to protect sealing surfaces and to prevent foreign material from entering the valve body cavity.

CAUTION

The ENVIRO-SEAL stem/bellows assembly for easy-e valves is available only with a threaded and pinned plug/adaptor/stem connection. The existing valve plug can be reused with the new stem/bellows assembly or a new plug can be installed. If the existing valve plug is reused, and the adaptor is in good condition, it may be reused also. However, never reuse an old adaptor with a new valve plug. Using an old adaptor with a new valve plug requires drilling a new pin hole in the adaptor. This drilling weakens the adaptor and may cause failure in service. However, a used valve plug may be reused with a new adaptor.

3. Inspect the existing valve plug and adaptor. If they are in good condition, they can be reused with the new stem/bellows assembly and they do not need to be separated.

CAUTION

When removing/installing a valve plug on the ENVIRO-SEAL stem/bellows assembly, the valve stem must not be rotated. Damage to the bellows may result.

Do not grip the bellows shroud or other parts of the stem/bellows assembly. Grip only the flat areas on the stem where it extends out of the top of the bellows shroud.

Note

The ENVIRO-SEAL stem/bellows assembly has a one-piece stem.

4. If the valve plug and adaptor are not in good condition and must be replaced, the valve plug/adaptor assembly must first be removed from the stem/bellows assembly and then the valve plug removed from the adaptor. First, place the stem/bellows assembly and valve plug in a soft-jaw chuck or other type of vise so that the jaws grip a portion of the valve plug that is not a seating surface. Drive out or drill out the pin (key 8). Drive out the pin (key 36, figure 21).
5. Then, reverse the stem/bellows and plug/adaptor assembly in the soft-jaw chuck or vise. Grip the flat areas on the valve stem just below the threads for the actuator/stem connection. Unscrew the plug/adaptor assembly from the stem/bellows assembly. Unscrew the valve plug from the adaptor.
6. To attach either the existing or a new valve plug to the stem of the new ENVIRO-SEAL stem/bellows assembly, first attach the plug to the adaptor (if the valve plug was removed from the adaptor) as follows:
 - Locate the adaptor. Notice that a hole has not been drilled in the new adaptor threads where the plug screws onto the adaptor.
 - Secure the valve plug in a soft-jaw chuck or other type of vise. Do not grip the plug on any seating surface. Position the plug in the chuck or vise for easy threading of the adaptor.

- Thread the adaptor into the valve plug and tighten to the appropriate torque value.
7. Complete the installation by following steps 7 through 15 of the ENVIRO-SEAL Bellows Seal Bonnet installation instructions given above.

Purging the ENVIRO-SEAL Bellows Seal Bonnet

The ENVIRO-SEAL bellows seal bonnet has been designed so that it can be purged or leak tested. Refer to figure 21 for an illustration of an ENVIRO-SEAL bellows seal bonnet. Perform the following steps for purging or leak testing.

1. Remove the two diametrically opposed pipe plugs (key 16, figure 21).
2. Connect a purging fluid to one of the pipe plug connections.
3. Install appropriate piping or tubing in the other pipe plug connection to pipe away the purging fluid or to make a connection to an analyzer for leak testing.
4. When purging or leak testing has been completed, remove the piping or tubing and reinstall the pipe plugs (key 16, figure 21).

Parts Ordering

Each body-bonnet assembly is assigned a serial number, which can be found on the valve. This same number also appears on the actuator nameplate when the valve is shipped from the factory as part of a control valve assembly. Refer to the serial number when contacting your [Emerson sales office](#) for technical assistance. When ordering replacement parts, refer to the serial number and to the 11-character part number for each part required from the following parts list.

⚠ WARNING

Use only genuine Fisher replacement parts. Components that are not supplied by Emerson Automation Solutions should not, under any circumstances, be used in any Fisher valve, because they may void your warranty, might adversely affect the performance of the valve, and could cause personal injury and property damage.

Parts Kits

Gasket Kits

Gasket Kits (includes keys 10, 12, 13, and 53; plus 11 and 14 for restricted trim)

| VALVE SIZE, NPS | Standard Trim Cage Whisper Trim I Cage Cavitrol III - 1 Stage Cage | Cavitrol III - 2 Stage Cage Whisper Trim III Cage WhisperFlo Cage |
|---------------------------------------|--|---|
| | -198 to 593°C (-325 to 1100°F) | |
| | Part Number | Part Number |
| 4x2 | RGASKETX182 | RGASKETX442 |
| 6x4x2-1/2 | RGASKETX282 | --- |
| 6x4 or 8x4 | RGASKETX212 | RGASKETX472 |
| 8x6 or 12x6 CL300, CL600, or CL900 | RGASKETX392 | --- |
| 8x6 or 12x6 Whisper Trim I | RGASKETX412 ⁽¹⁾ | --- |
| 10x8 or 12x8 | RGASKETX232 | 10A3265X152 |

1. Includes a quantity 2 of key 10.

Packing Kits

Standard Packing Repair Kits

Packing repair kits for standard packing include keys 6, 8, 10, 11 and 12.

Note

Kits do not apply to alloy C (N10276 and CW2M), Alloy 20 (N08020 and CN7M), or alloy 400 (N04400 and M35-1) trims.

Standard Packing Repair Kits (Non Live-Loaded)

| Stem Diameter, mm (Inches) Yoke Boss Diameter, mm (Inches) | 12.7 (1/2) 71 (2-13/16) | 19.1 (3/4) 90 (3-9/16) | 25.4 (1) 127 (5) | 31.8 (1-1/4) 127 (5, 5H) |
|--|----------------------------|---------------------------|---------------------|-----------------------------|
| PTFE (Contains keys 6, 8, 10, 11, and 12) | RPACKX00022 | RPACKX00032 | RPACKX00342 | RPACKX00352 |
| Double PTFE (Contains keys 6, 8, 11, and 12) | RPACKX00052 | RPACKX00062 | RPACKX00362 | RPACKX00372 |
| PTFE/Composition (Contains keys 7, 8, 11, and 12) | RPACKX00082 | RPACKX00092 | --- | --- |
| Single Graphite Ribbon/Filament (Contains keys 7 [ribbon ring], 7 [filament ring], 8, and 11) | RPACKX00112 | RPACKX00122 | --- | --- |
| Single Graphite Ribbon/Filament (Contains keys 7 [ribbon ring], 7 [filament ring], and 11) | --- | --- | RPACKX00532 | RPACKX00542 |
| Single Graphite Ribbon/Filament (Contains keys 7 [ribbon ring], 7 [filament ring]) | RPACKX00142 | RPACKX00152 | --- | --- |
| Double Graphite Ribbon/Filament (Contains keys 7 [ribbon ring], 7 [filament ring], 8, and 11) | RPACKX00172 | RPACKX00182 | --- | --- |

HIGH-SEAL and ENVIRO-SEAL Packing Retrofit Kits

Retrofit kits include parts to convert valves with existing standard bonnets to the HIGH-SEAL or ENVIRO-SEAL packing box construction. Refer to figure 17 for key numbers for HIGH-SEAL packing. For ENVIRO-SEAL packing, refer to figure 18 for PTFE packing key numbers, figure 19 for Graphite ULF packing key numbers, and figure 20 for duplex packing key numbers.

Stems and packing box constructions that do not meet Emerson stem finish specifications, dimensional tolerances, and design specifications, may adversely alter the performance of this packing kit.

HIGH-SEAL Packing Retrofit Kits

| Stem Diameter, mm (Inches) Yoke Boss Diameter, mm (Inches) | 12.7 (1/2) 71 (2-13/16) | 19.1 (3/4) 90 (3-9/16) | 25.4 (1) 127 (5) | 31.8 (1-1/4) 127 (5, 5H) |
|---|----------------------------|---------------------------|---------------------|-----------------------------|
| 4200 psi Process Pressure Rating (Contains keys 200 through 212) | 11B2182X052 | 11B2184X052 | 11B2187X052 | 11B2189X052 |

ENVIRO-SEAL Packing Retrofit Kits

| Stem Diameter, mm (Inches) Yoke Boss Diameter, mm (Inches) | 12.7 (1/2) 71 (2-13/16) | 19.1 (3/4) 90 (3-9/16) | 25.4 (1) 127 (5) | 31.8 (1-1/4) 127 (5, 5H) |
|---|----------------------------|---------------------------|---------------------|-----------------------------|
| Double PTFE (Contains keys 200, 201, 211, 212, 214, 215, 217, 218, tag, cable tie) | RPACKXRT022 | RPACKXRT032 | RPACKXRT042 | RPACKXRT052 |
| Graphite ULF (Contains keys 200, 201, 207, 208, 209, 210, 211, 212, 214, 217, tag, cable tie) | RPACKXRT272 | RPACKXRT282 | RPACKXRT292 | RPACKXRT302 |
| Duplex (Contains keys 200, 201, 207, 209, 211, 212, 214, 215, 216, 217, tag, cable tie) | RPACKXRT222 | RPACKXRT232 | RPACKXRT242 | RPACKXRT252 |

ENVIRO-SEAL Packing Repair Kits

Repair kits include parts to replace the "soft" packing materials in valves that already have ENVIRO-SEAL packing arrangements installed or in valves that have been upgraded with ENVIRO-SEAL retrofit kits. Refer to figure 18 for key numbers for PTFE packing, figure 19 for key numbers for Graphite ULF packing, and figure 20 for key numbers for duplex packing.

Stems and packing box constructions that do not meet Emerson stem finish specifications, dimensional tolerances, and design specifications, may adversely alter the performance of this packing kit.

ENVIRO-SEAL Packing Repair Kits

| Stem Diameter, mm (Inches) Yoke Boss Diameter, mm (Inches) | 12.7 (1/2) 71 (2-13/16) | 19.1 (3/4) 90 (3-9/16) | 25.4 (1) 127 (5) | 31.8 (1-1/4) 127 (5, 5H) |
|---|----------------------------|---------------------------|---------------------|-----------------------------|
| Double PTFE (Contains keys 214, 215, 218) | RPACKX00202 | RPACKX00212 | RPACKX00222 | RPACKX00232 |
| Graphite ULF (Contains keys 207, 208, 209, 210, 214) | RPACKX00602 | RPACKX00612 | RPACKX00622 | RPACKX00632 |
| Duplex (Contains keys 207, 209, 214, 215) | RPACKX00302 | RPACKX00312 | RPACKX00322 | RPACKX00332 |

Figure 17. Typical Fisher HIGH-SEAL Packing System

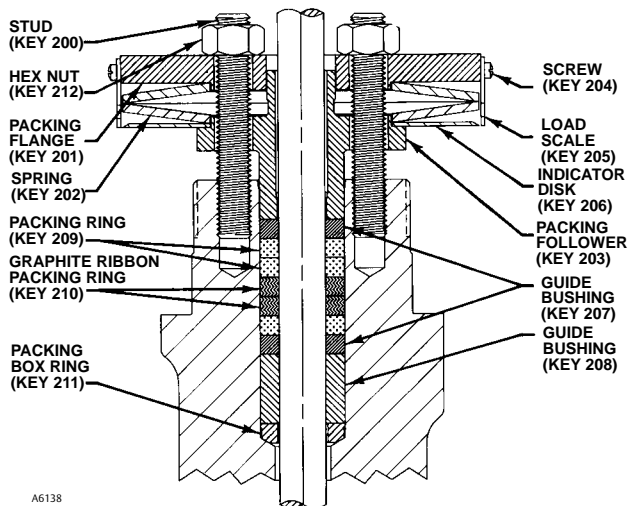

A6138

Figure 19. Typical Fisher ENVIRO-SEAL Packing System with Graphite ULF Packing

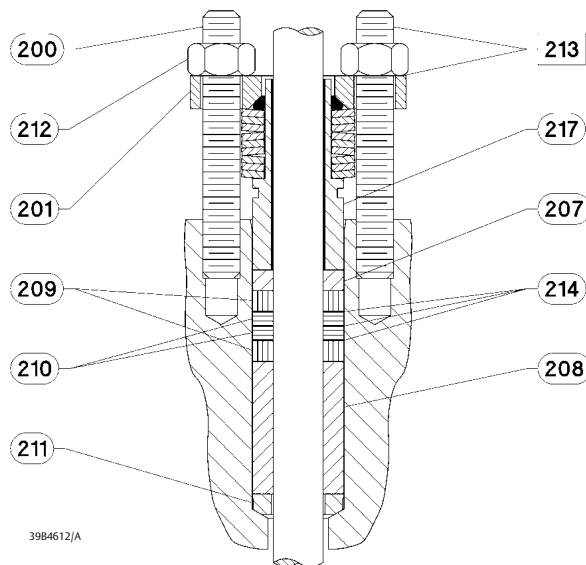

3984612/A

Figure 18. Typical Fisher ENVIRO-SEAL Packing System with PTFE Packing

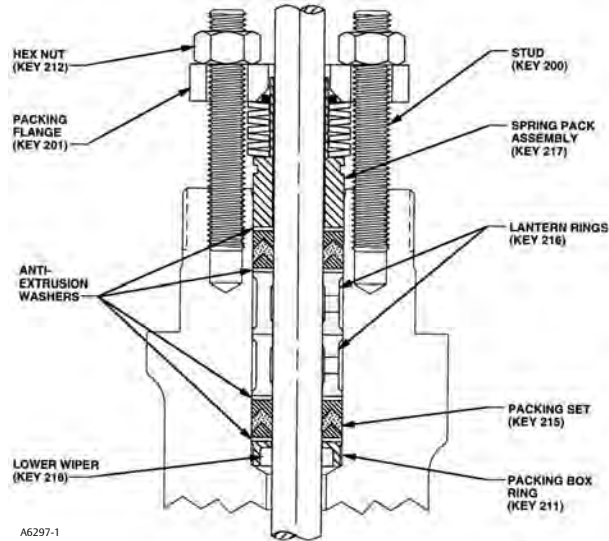

A6297-1

Figure 20. Typical Fisher ENVIRO-SEAL Packing System with Duplex Packing

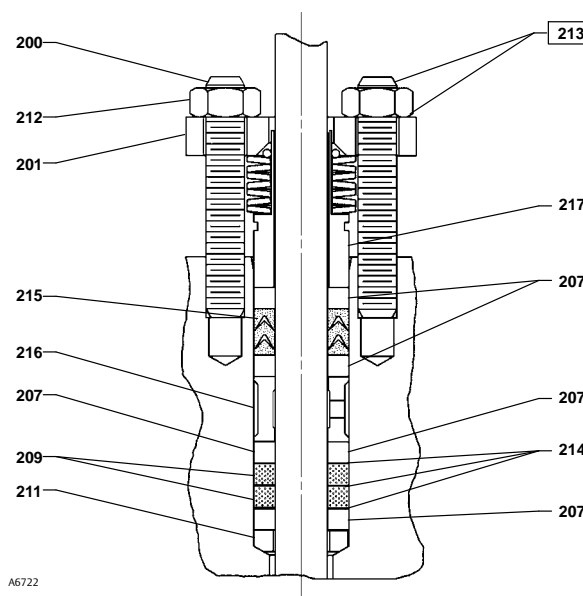

A6722

Parts List

Note

Contact your [Emerson sales office](#) for part numbers.

Bonnet (figures 4, 5, 6, and 21)

| Key | Description |
|-----|---|
| 1 | Bonnet |
| 2 | Extension Bonnet Bushing |
| 3 | Packing Flange |
| 3 | ENVIRO-SEAL bellows seal packing flange |
| 4 | Packing Flange Studs |
| 4 | ENVIRO-SEAL bellows seal stud bolt (2 req'd) |
| 5 | Packing Flange Nuts |
| 5 | ENVIRO-SEAL bellows seal packing flange nut (2 req'd) |
| 6* | Single PTFE V-Ring Packing Set |
| 6* | ENVIRO-SEAL bellows seal packing set |
| 7* | Individual Packing Ring |
| 7* | ENVIRO-SEAL bellows seal packing ring |
| 7* | ENVIRO-SEAL bellows seal packing ring |
| 8 | Packing Box Spring or Lantern Ring |
| 8 | ENVIRO-SEAL bellows seal spring |
| 8 | ENVIRO-SEAL bellows seal spacer |
| 9* | Individual Packing Ring |
| 10 | Special Washer |
| 11* | Packing Box Ring |
| 12* | Upper Wiper |
| 12* | ENVIRO-SEAL bellows seal upper wiper |
| 13 | Packing follower |
| 13* | ENVIRO-SEAL bellows seal bushing |
| 13* | ENVIRO-SEAL bellows seal bushing/liner |
| 14 | Packing Box Pipe Plug |
| 14 | Lubricator |
| 14 | Lubricator/Isolating Valve Assembly |
| 15 | Yoke Locknut |
| 15 | ENVIRO-SEAL bellows seal yoke locknut |
| 16 | Pipe Plug for double-tapped bonnet |
| 16 | ENVIRO-SEAL bellows seal pipe plug (2 req'd) |
| 20* | ENVIRO-SEAL bellows seal stem/bellows assembly |
| 22* | ENVIRO-SEAL bellows seal bonnet gasket |
| 24 | ENVIRO-SEAL bellows seal adaptor |
| 25 | Cap Screw for yoke boss (8 req'd) |
| 26 | Hex Nut for yoke boss (8 req'd) |
| 27 | Pipe Nipple for lubricator/isolating valve |
| 28 | Warning Nameplate for ENVIRO-SEAL bellows |
| 29 | Drive Screw for ENVIRO-SEAL bellows (2 req'd) |
| 36* | ENVIRO-SEAL bellows seal pin |
| 37 | Warning Tag for ENVIRO-SEAL bellows |
| 38 | Tie for ENVIRO-SEAL bellows |
| 39 | ENVIRO-SEAL bellows seal thrust ring |

Figure 21. Typical Fisher Bonnet with Single PTFE V-Ring Packing Set

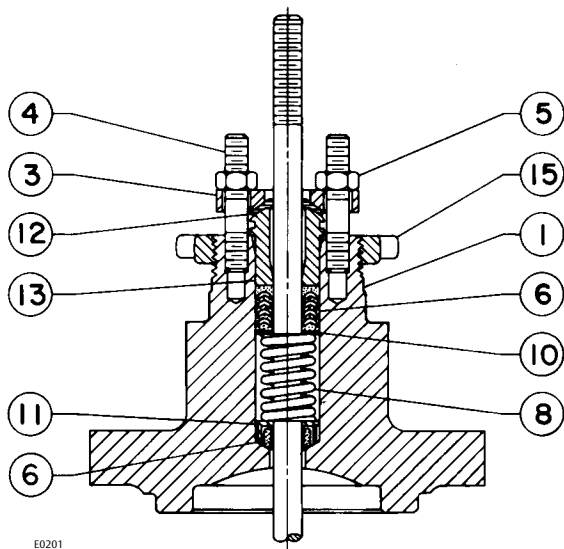

PLAIN BONNET

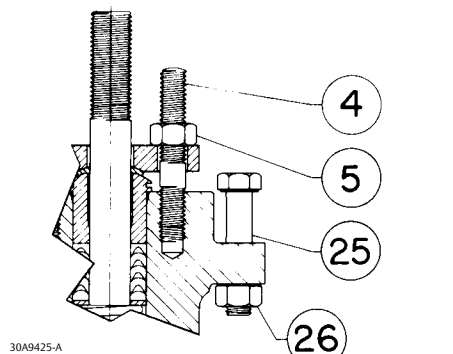

DETAIL OF 5-INCH (127 mm) YOKE BOSS ACTUATOR BOLTING

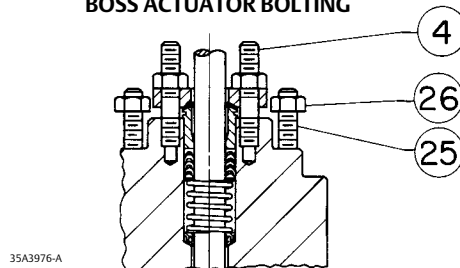

DETAIL OF NPS 12x8 CL900 YOKE BOSS BOLTING

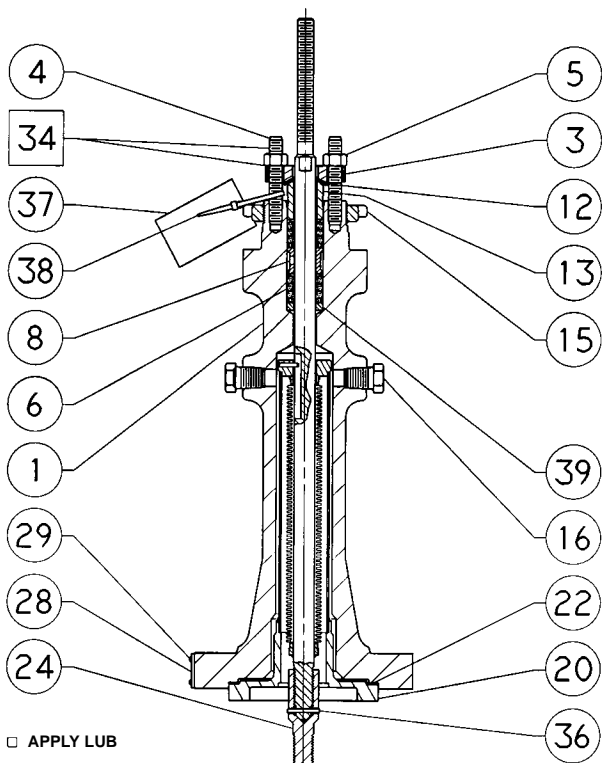

□ APPLY LUB

ENVIRO-SEAL BELLOWS SEAL BONNET

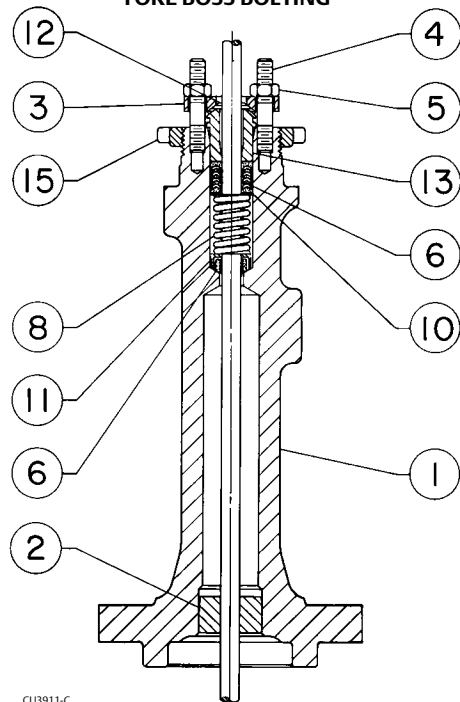

STYLE 1 OR 2 EXTENSION BONNET

42B3947-A

CU3911-C

Key Description

Valve Body (figures 22 through 24)

| | |
|--------------|---|
| 1 | Valve Body If you need a valve body as a replacement part, order by valve size, serial number, and desired material. |
| 2* | Valve Plug |
| 3* | Cage |
| 4 | Cage Adaptor |
| 5 | Seat Ring Adaptor |
| 6* | EWD Piston Ring |
| 7* | Valve Plug Stem |
| 8* | Pin |
| 9* | Seat Ring |
| 10* thru 14* | Gaskets |
| 15 | Stud Bolt |
| 16 | Stud Bolt Nut |
| 17 | Pipe Plug for drain-tapped valve |
| 18 | Flow Arrow |
| 19 | Drive screw (6 req'd) |
| 21* | Disk Retainer |
| 22* | Disk Seat |
| 23* | Disk |
| 26 | Load Ring for Size 10x8 or 12x8 valve only |
| 27* | Retaining Ring for spring-loaded EWT seal rings |
| 28* | EWT 2-Piece Seal Ring for all except Cavitrol III constructions |
| 29* | Backup Ring |
| 31* | Cage Retainer Required for Whisper Trim III and Cavitrol III cages only. |
| 32 | Bonnet Spacer |
| 51 | Anti-seize lubricant (not furnished) |
| 52 | Cage Spacer |
| 53* | Shim |
| 55 | Wire |

Key Description

C-seal Trim (figure 9)

| | |
|-----|-----------------|
| 2* | Plug/Retainer |
| 3* | Cage |
| 7* | Valve Plug Stem |
| 9* | Seat Ring |
| 64* | C-seal |

TSO Trim (figures 7 and 8)

| | |
|-----|---------------------|
| 3* | Cage |
| 9* | Seat Ring |
| 2* | Plug/Stem Assembly |
| 28* | Seal Ring |
| 63* | Anti-Extrusion Ring |
| 29* | Back Up Ring |
| 27* | Retaining Ring |

Figure 22. Fisher EWD Valve through NPS 12x6 with Optional Drain Plug

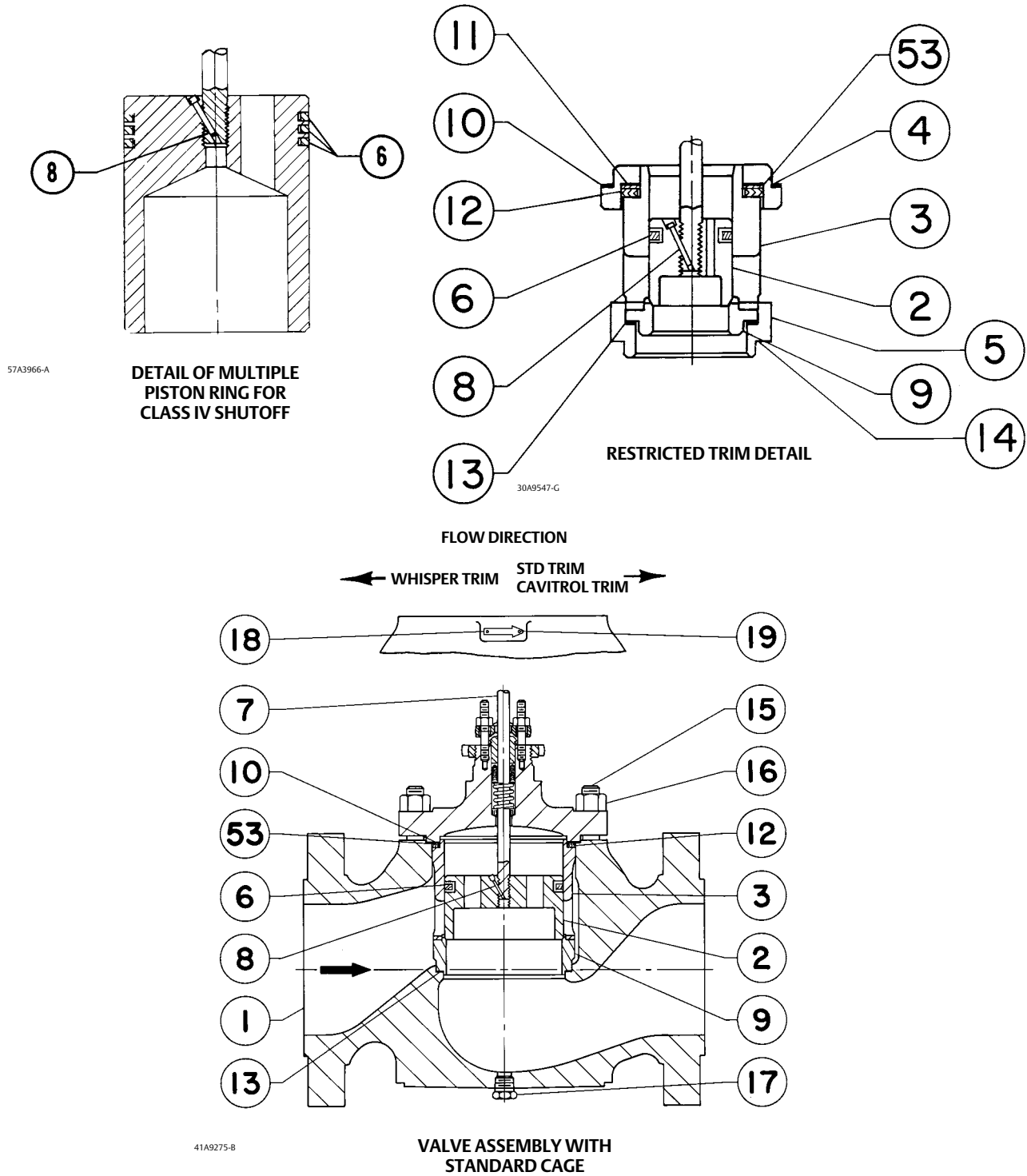
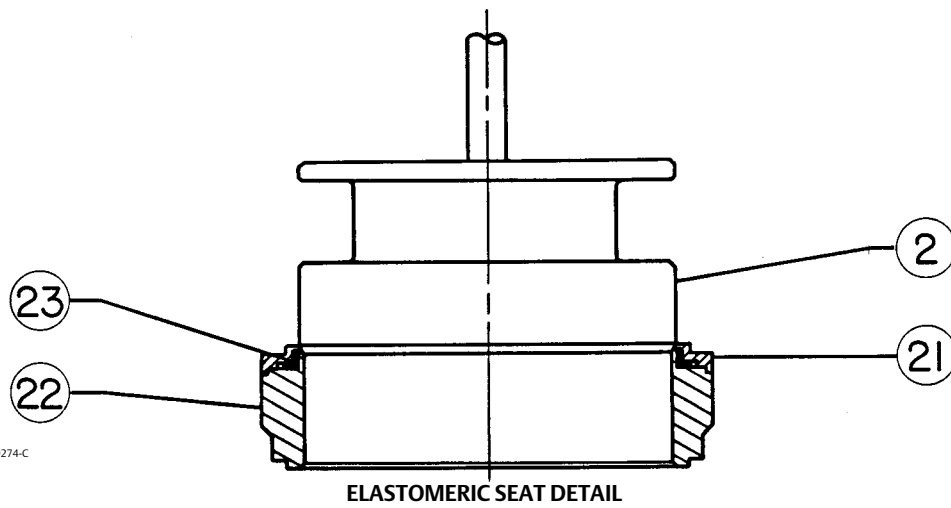
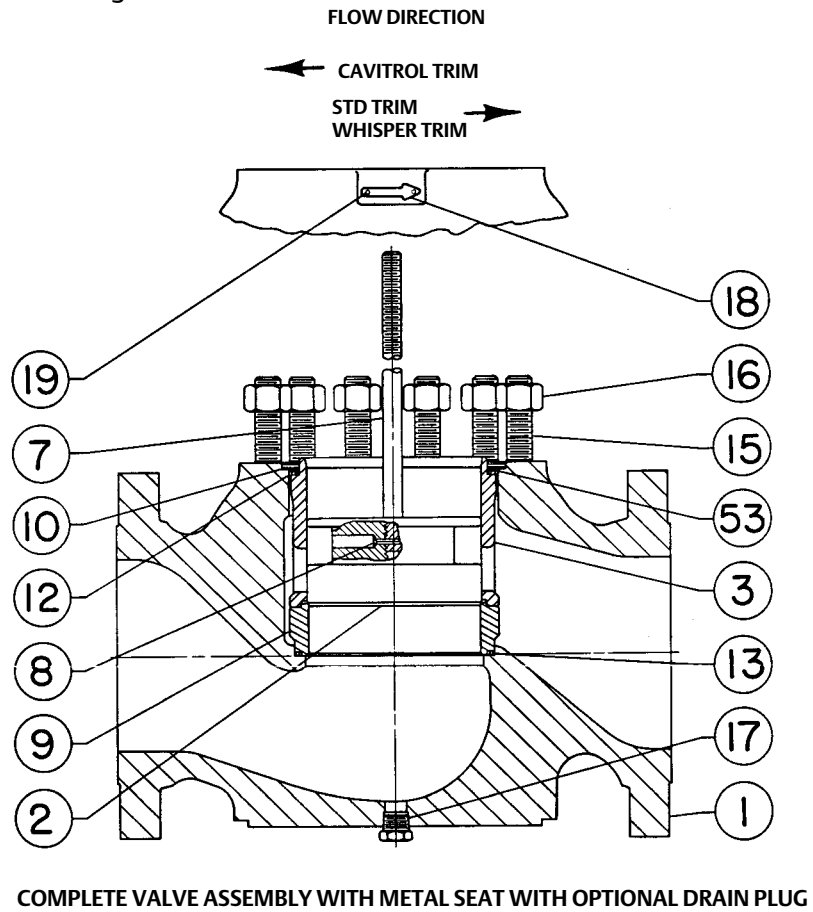

Figure 23. Fisher EWS Valve through NPS 12x6



31A9274-C

Figure 24. Typical Fisher EWT Valve Assemblies

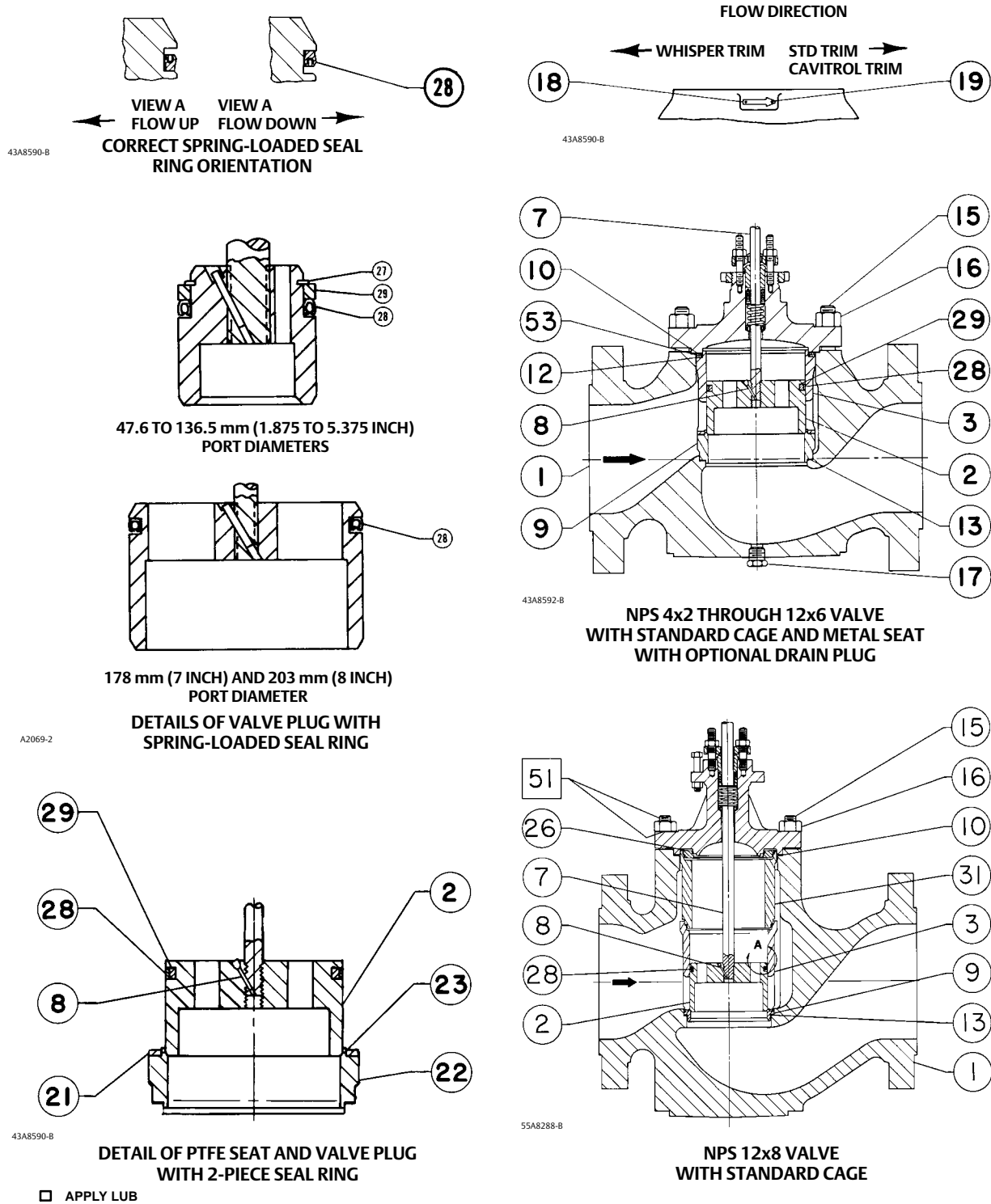
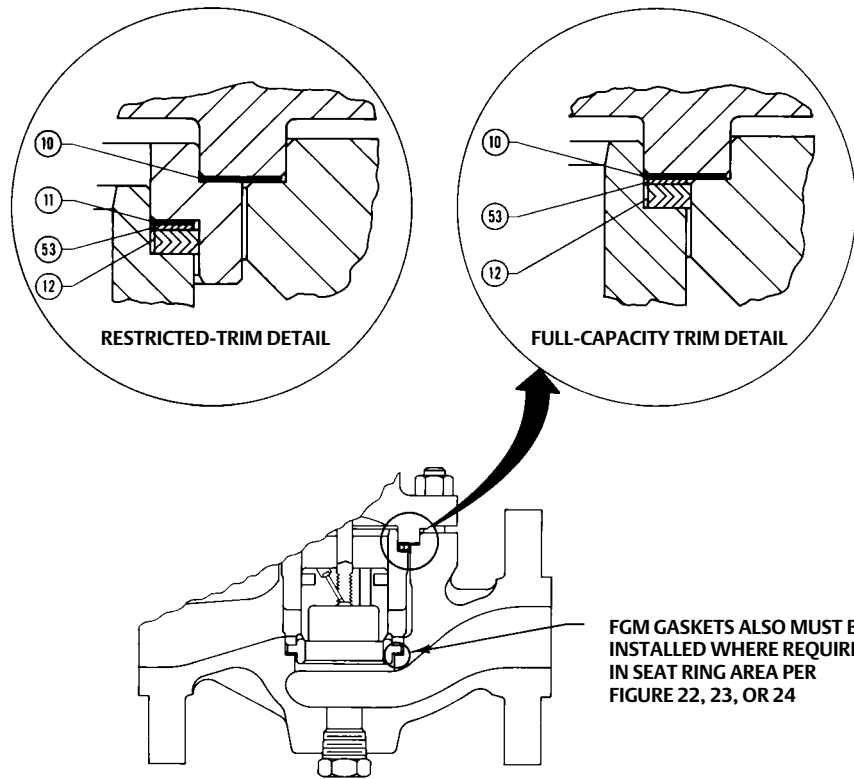

Figure 25. FGM Gasket Detail with Optional Drain Plug



A2713*

Figure 26. NPS 4x2 Through 12x8 Fisher Valves with 1-Stage Cavitrol III Cage

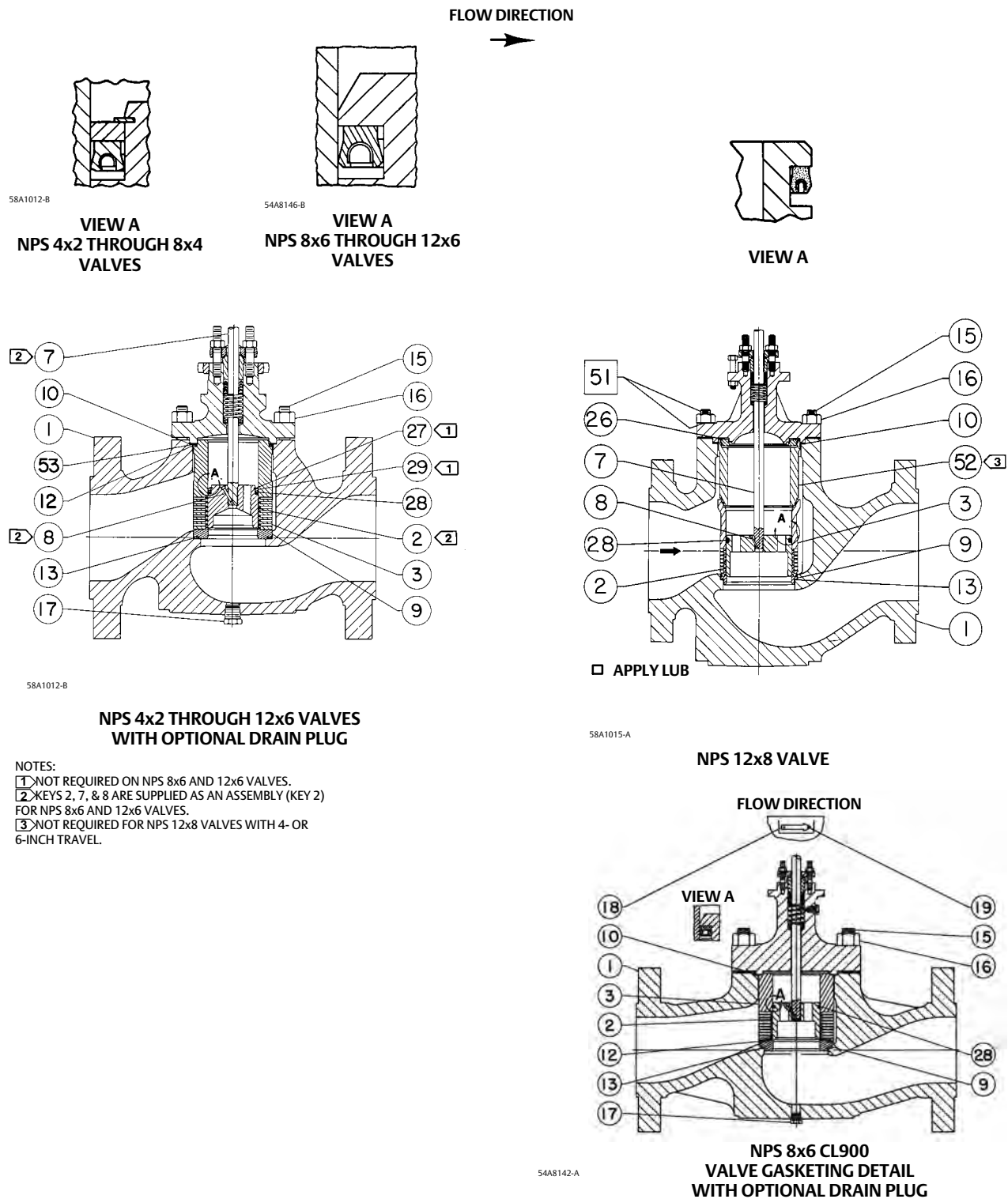

Figure 27. NPS 4x2 Through 12x8 Fisher Valves with 2-Stage Cavitrol III Cage

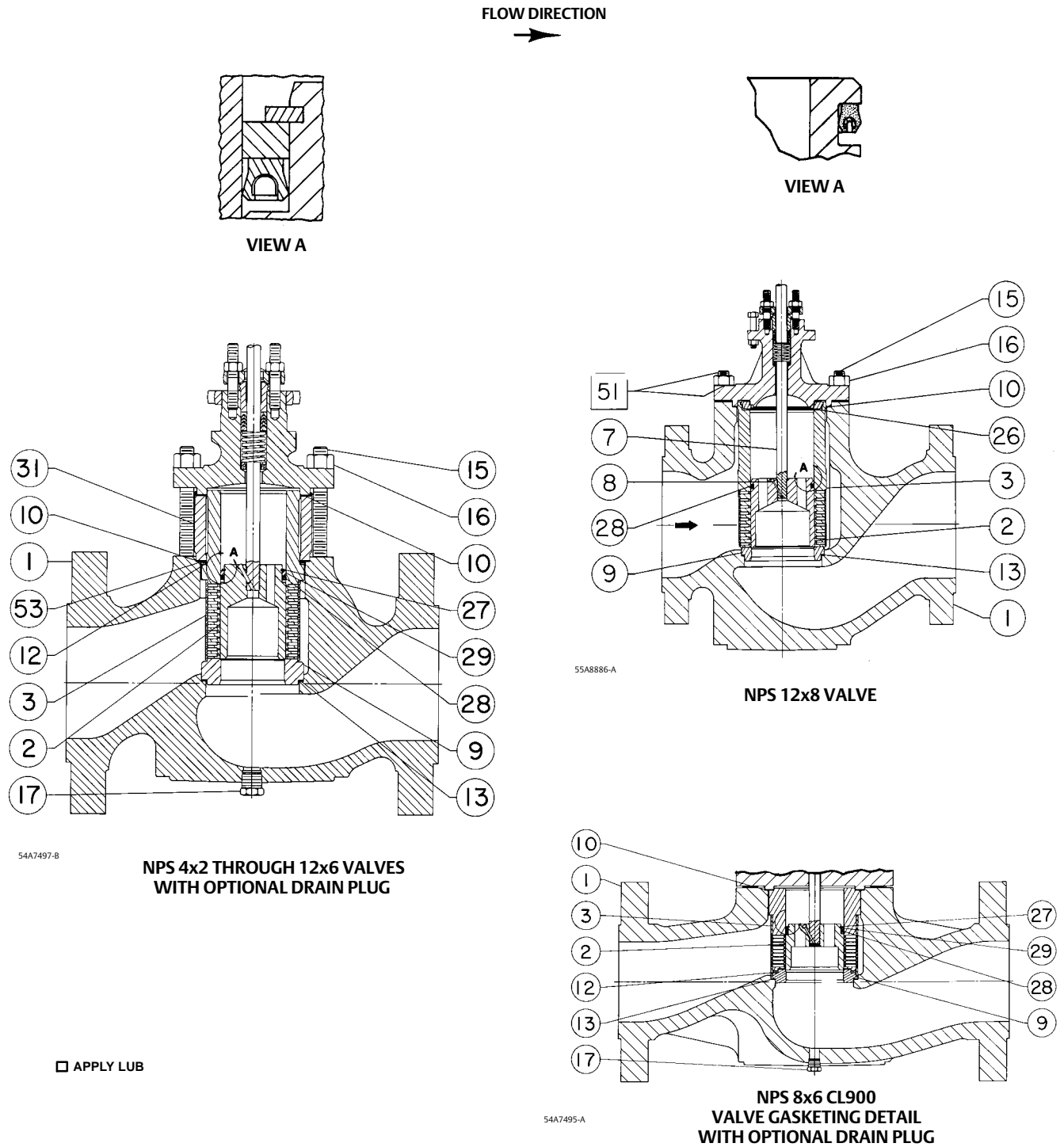

Figure 28. Typical Fisher EWD Valve with Whisper Trim III Cage

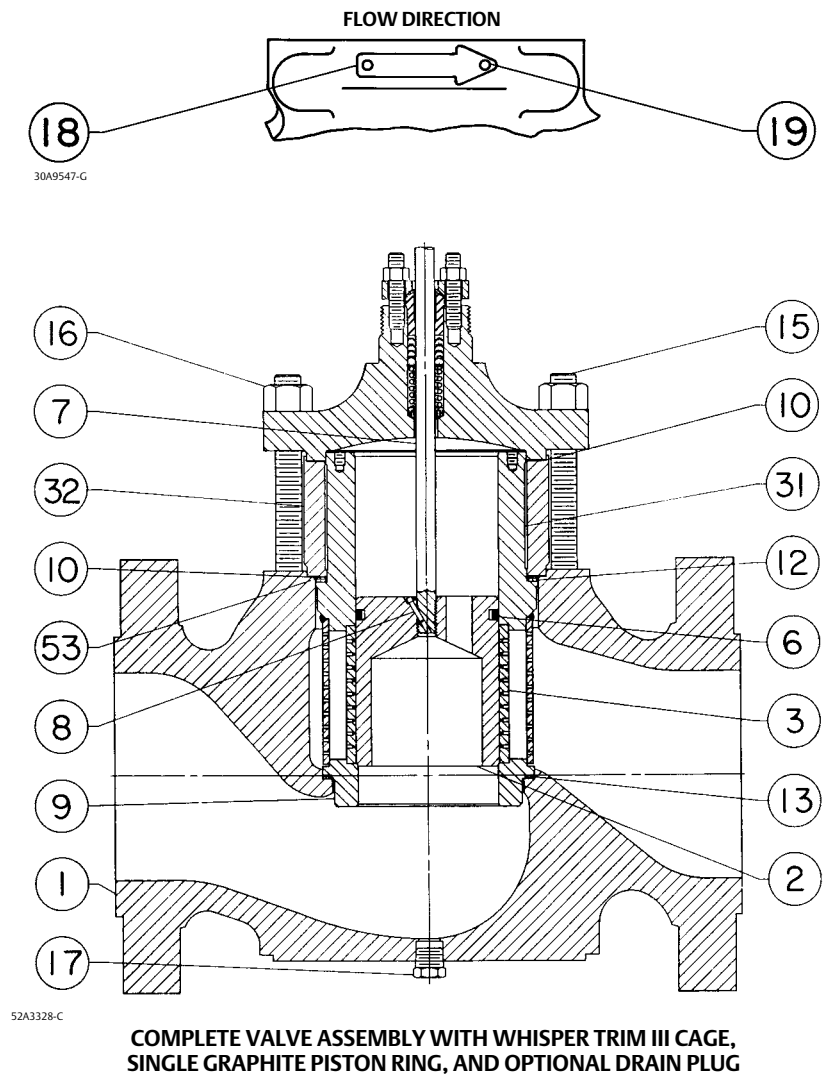
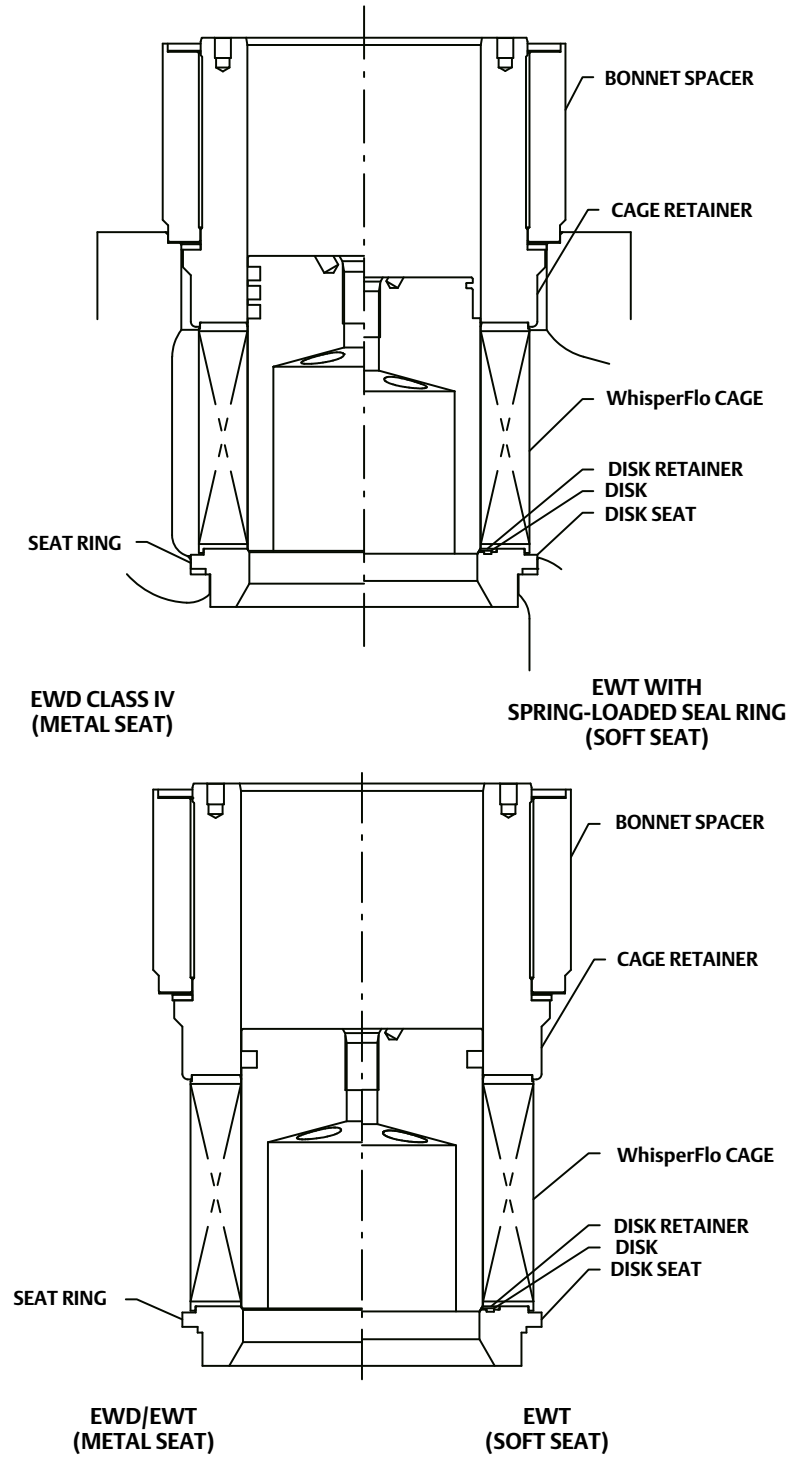

Figure 29. Typical Fisher WhisperFlo Trims



Gasket Descriptions

| KEY NUMBER | DESCRIPTION | MATERIAL |
|------------|---------------------------|--|
| | | FGM -198 TO 593 °C (-325 TO 1100 °F) |
| 10 | Bonnet Gasket | Graphite/S31600 |
| 11 | Cage Gasket | |
| 13 | Seat Ring or Liner Gasket | |
| 14 | Adapter Gasket | |
| 12 | Spiral-Wound Gasket | N06600/Graphite |
| 53 | Shim | S31600 |

Actuator Groups (by Type Number)

| Group 1 54 mm (2-1/8 inches), 71 mm (2-13/16 inches) or 90 mm (3-9/16 inches) Yoke Boss | Group 100 127 mm (5 inches) Yoke Boss | Group 101 127 mm (5 inches) Yoke Boss | Group 403 90.5 mm (3-9/16 inches) Yoke Boss |
|--|---|---|---|
| 585C Series—50.8 mm (2 inches) travel | 585C | 667 | 585C |
| 472 & 473 | 472 | | 1008 |
| 657 & 667—76.2 mm (3 inches) travel | 473 | | |
| 1008—71.4 mm (2-13/16 inches) yoke boss | 657 | | |
| | 1008 | | |

Neither Emerson, Emerson Automation Solutions, nor any of their affiliated entities assumes responsibility for the selection, use or maintenance of any product. Responsibility for proper selection, use, and maintenance of any product remains solely with the purchaser and end user.

Fisher, ENVIRO-SEAL, WhisperFlo, Whisper Trim, Cavitrol, and easy-e are marks owned by one of the companies in the Emerson Automation Solutions business unit of Emerson Electric Co. Emerson Automation Solutions, Emerson, and the Emerson logo are trademarks and service marks of Emerson Electric Co. All other marks are the property of their respective owners.

The contents of this publication are presented for informational purposes only, and while every effort has been made to ensure their accuracy, they are not to be construed as warranties or guarantees, express or implied, regarding the products or services described herein or their use or applicability. All sales are governed by our terms and conditions, which are available upon request. We reserve the right to modify or improve the designs or specifications of such products at any time without notice.

Emerson Automation Solutions
Marshalltown, Iowa 50158 USA
Sorocaba, 18087 Brazil
Cernay 68700 France
Dubai, United Arab Emirates
Singapore 128461 Singapore

www.Fisher.com

