

Vee-Ball® Designs V150 and V300 14- through 20-inch Rotary Control Valves

Contents

Introduction	1
Scope of Manual	1
Description	1
Specifications	3
Installation	3
Maintenance	5
Packing Maintenance	5
Stopping Leakage	5
Packing Replacement	6
Disassembly	6
Assembly	6
Ball Seal Replacement	7
Disassembly	9
Assembly	9
Bearing and Ball Maintenance	11
Disassembly	11
Assembly	12
Actuator Mounting	14
Determining Open Position	15
Parts Ordering	16
Parts List	16

Introduction

Scope of Manual

This instruction manual provides installation, operation, maintenance, and parts ordering information for 14, 16, and 20-inch Design V150 and for 14 and 16-inch Design V300 rotary control valves. For smaller valves (1- through 12-inch size), refer to the Vee-Ball® Designs V150, V200 and V300 Rotary Control Valves Sizes 1- through 12-inch instruction manual (form 5290). For information on ENVIRO-SEAL® packing, see the ENVIRO-SEAL Packing System for Rotary Valves instruction manual (form 5305). Refer to separate manuals for



W6087/IL

Figure 1. Design V150 and V300 Vee-Ball Size 16-Inch Valve

information concerning the actuator, positioner, and mounted accessories.

No person may install, operate, or maintain a Design V150 or V300 valve without first (1) being fully trained and qualified in valve, actuator and accessory installation, operation and maintenance, and (2) carefully reading and understanding the contents of this manual. If you have any questions about these instructions, contact your Fisher sales office before proceeding.

Description

The Design V150 or V300 Vee-Ball valve with a V-notch ball is used in throttling or on-off service. The Design V150 valve (figure 1) is a raised-face flanged construction available in Class 150. The Design V300 valve is a raised-face flanged construction available in Class 300. The splined valve shaft connects to a variety of rotary actuators.



V150 & V300 Valves

Table 1. Specifications

<p>Valve Sizes and End Connection Styles</p> <p>Design V150: 14, 16, and 20-inch sizes with Class 150 raised-face flanges as shown in table 3</p> <p>Design V300: 14 and 16-inch sizes with Class 300 raised-face flanges as shown in table 3</p> <p>Standard Flow Direction</p> <p>Forward (into the convex sealing face of the ball)</p> <p>Actuator Mounting</p> <p>■ Right-hand, or ■ left-hand as viewed from the upstream end of the valve. Standard valve construction with standard ball rotation is with right-hand mounting. Optional valve construction</p>	<p>with optional ball rotation for left-hand mounting is available upon request.</p> <p>Ball Rotation</p> <p>Standard: Ball rotates Counterclockwise to Close (CCW) when viewed from actuator side of valve</p> <p>Optional: Ball rotates Clockwise to Close (CW)</p> <p>Maximum ball rotation is 90 degrees</p> <p>Valve/Actuator Action</p> <p>With diaphragm or piston rotary actuator, field-reversible between push-down-to-close (extending actuator rod closes valve) and push-down-to-open (extending actuator rod opens valve)</p>
---	---

Table 2. Valve Sizes, Drive Shaft Diameters, and Valve Assembly Weights

VALVE SIZE		DRIVE SHAFT DIAMETER		VALVE ASSEMBLY WEIGHT			
mm	Inch	mm	Inch	kg		lb	
				V150	V300	V150	V300
350	14	44.5	1-3/4	206	374	545	825
400	16	54.0	2-1/8	333	510	735	1125
		54.0 x 50.8	2-1/8 x 2				
500 ⁽¹⁾	20 ⁽¹⁾	63.5	2-1/2	524	---	1155	---

1. 20-Inch size available only for V150, not for V300 valves.

Table 3. Valve Sizes, End Connection Styles, and Ratings⁽¹⁾⁽²⁾

VALVE BODY MATERIAL	FLANGE COMPATIBILITY	RATING	FACE-TO-FACE DIMENSION
WCC steel (standard)	ANSI Class 150 (V150) raised-face	ASME B16.34 Class 150	14 and 16-Inch Valves: ASME B16.10 Short 20-Inch Valves: 508 mm (20 inches)
	ANSI Class 300 (V300) raised-face	ASME B16.34 Class 300	14-inch Valves: 381 mm (15 inches) 16-inch Valves: 406 mm (16 inches)
CG8M (317 SST)	ANSI Class 150 (V150) raised-face	ASME B16.34 Class 150	14 and 16-Inch Valves: ASME B16.10 Short 20-Inch Valves: 508 mm (20 inches)
	ANSI Class 300 (V300) raised-face	ASME B16.34 Class 300	14-inch Valves: 381 mm (15 inches) 16-inch Valves: 406 mm (16 inches)

1. Do not exceed the material temperature capabilities or the pressure drop limitations shown in bulletin 51.3:Vee-Ball.
2. The pressure/temperature limits in this manual and any application code limitations, should not be exceeded.

Specifications

Specifications for these valves are shown in table 1 and bulletin 51.3:Vee-Ball.

Installation

Key numbers are shown in figure 10, unless otherwise indicated.

WARNING

Always wear protective gloves, clothing, and eyewear when performing any maintenance operations to avoid personal injury.

Personal injury or equipment damage caused by sudden release of pressure may result if the valve assembly is installed where service conditions could exceed either the valve body rating or the mating pipe flange joint rating. To avoid such injury or damage, provide a relief valve for overpressure protection as required by government or accepted industry codes and good engineering practices.

Check with your process or safety engineer for any additional measures that must be taken to protect against process media.

CAUTION

When ordered, the valve configuration and construction materials were selected to meet particular pressure, temperature, pressure drop and controlled fluid conditions. Responsibility for the safety of process media and compatibility of valve materials with process media rests solely with the purchaser and end-user. Since some valve body/trim material combinations are limited in their pressure drop and temperature ranges, do not apply any other conditions to the valve without first contacting your Fisher sales office.

Fisher does not assume final responsibility for the selection, use, or maintenance of any product. Final responsibility for the selection, use, and maintenance of any Fisher product remains with the purchaser and end-user.

Install the valve with the drive shaft in the horizontal position as shown in figure 1.

WARNING

Do not allow the valve to be installed in the pipeline with the drive shaft in the vertical position because of excessive wear to component valve parts.

1. If the valve is to be stored before installation, protect the flange mating surfaces and keep the valve cavity dry and free of foreign material.
2. Install a three-valve bypass around the control valve assembly if continuous operation will be necessary during inspection and maintenance of the valve.
3. **Mounting the Actuator:**
 - a. The valve is normally shipped as part of a control valve assembly, with the actuator mounted on the valve. The factory makes actuator/valve adjustments before the valve is shipped.
 - b. If the valve and actuator have been purchased separately or if the actuator has been removed, mount the actuator according to the Actuator Mounting section of this manual.
4. Be certain the valve and adjacent pipelines are free of any foreign material that could damage the valve seating surfaces.
5. Be sure the mating line flanges are aligned. Provide standard flat sheet flange gaskets (or spiral wound gaskets with compression-controlling centering rings) that are compatible with the process fluid.
Refer to figure 2 for required clearance for valve installation and stud length. Lubricate the studs with Never-Seez Pure Nickel Special or an equivalent lubricant.
6. Install the valve using studs and nuts to connect the valve flanges to the pipeline flanges. The seal protector ring (key 3) end of the valve requires longer line flange studs than standard (see figure 2).

V150 & V300 Valves

VALVE SIZE, INCHES	DIMENSION						
	A		B	M ⁽²⁾ (Min.)		N	
	Class 150 ANSI B16.10 (Short) ⁽¹⁾	Class 300		Class 150 ANSI B16.10 (Short) ⁽¹⁾	Class 300	Class 150	Class 300
mm							
14	381	381	175	152	197	133	178
16	406	406	178	152	210	133	190
20 ⁽³⁾	508	---	235 ⁽³⁾	178	---	159	---
Inch							
14	15.00	15.00	6.88	6.00	7.75	5.25	7.00
16	16.00	16.00	7.00	6.00	8.25	5.25	7.50
20 ⁽³⁾	20.00	---	9.25 ⁽³⁾	7.00	---	6.25	---

1. ANSI B16.10 (Short) applies to 14 and 16-inch valves only.
 2. Inlet flange stud bolt length is longer than the standard length as specified in ANSI B16.5.
 3. 20-inch, class 150 valves do not comply with ANSI B16.10 (Short). 20-inch valves are not available in class 300.

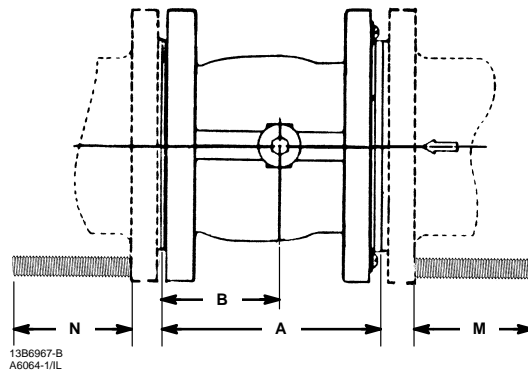

Figure 2. Required Clearances for Installation of Design V150 and V300 Valves

Do not attempt to use standard-length line flange studs for the seal protector end of the valve. Refer to figure 2 for length of flange studs required.

Install all remaining studs. Tighten the nuts in a criss-cross sequence to ensure the flange gaskets are properly loaded.

Standard PTFE packing is composed of a partially conductive carbon-filled PTFE female adaptor with PTFE V-ring packing. Standard graphite packing is composed of all conductive graphite ribbon packing rings. Alternate shaft-to-valve body bonding is available for hazardous service areas where the standard packing is not sufficient to bond the shaft to the valve (see the following step and figure 4).

WARNING

The valve drive shaft is not necessarily grounded to the pipeline when installed. Personal injury or property damage could result if the process fluid or the atmosphere around the valve is flammable, from an explosion caused by a discharge of static electricity from the valve components. If the valve is installed in a hazardous area, electrically bond the drive shaft to the valve.

7. For hazardous applications, attach the optional bonding strap assembly (key 131, figure 4) to the valve drive shaft (key 6) with the clamp (key 130, figure 4) and connect the other end of the bonding strap assembly to the valve body with the cap screw (key 23).

8. Connect pressure lines to the actuator as indicated in the actuator instruction manual. When an auxiliary manual actuator is used with a power actuator, install a bypass valve on the power

actuator (if one is not supplied) for use during manual operation.



WARNING

Personal injury could result from packing leakage. Valve packing was tightened before shipment; however, the packing might need some readjustment to meet specific service conditions. Check with your process or safety engineer for any additional measures that must be taken to protect against process media.

If the valve has ENVIRO-SEAL live-loaded packing installed, this initial re-adjustment will probably not be required. Refer to the ENVIRO-SEAL Packing System for Rotary Valves instruction manual (form 5305) for packing instructions.

Maintenance

Valve parts are subject to normal wear and must be inspected and/or replaced as necessary. The frequency of inspection and replacement depends upon the severity of service conditions.



WARNING

The Vee-ball closes with a cutting motion. To avoid personal injury, keep hands, tools, and other objects away from the ball while stroking the valve.

Avoid personal injury from sudden release of process pressure. Before performing any maintenance operations:

- Disconnect any operating lines providing air pressure, electric power, or a control signal to the actuator. Make sure the actuator cannot suddenly open or close the valve.
- Use bypass valves or completely shut off the process to isolate the valve from process pressure. Relieve process pressure on both sides of the valve. Drain the process media from both sides of the valve.

- Vent the power actuator loading pressure.

- Use lock-out procedures to be sure that the above measures stay in effect while you work on the equipment.

- Always wear protective gloves, clothing, and eyewear when performing any maintenance operations to avoid personal injury.

- The valve packing area may contain process fluids that are pressurized, even when the valve has been removed from the pipeline. Process fluids may spray out under pressure when removing the packing hardware or packing rings.

- Check with your process or safety engineer for any additional measures that must be taken to protect against process media.

Packing Maintenance

Key numbers are shown in figure 10, unless otherwise indicated. A detailed view of the packing is also shown in figure 3.

If the valve is equipped with the ENVIRO-SEAL Packing System, refer to the ENVIRO-SEAL Packing System for Rotary Valves instruction manual (form 5305).

Note

For the ENVIRO-SEAL Packing System, refer to the Parts List section for individual parts (see figure 3). Refer to the ENVIRO-SEAL Packing System for Rotary Valves instruction manual (form 5305) for maintenance instructions.

Stopping Leakage

For PTFE V-ring packing, leakage around the packing follower and packing flange (keys 17 and 40) can be stopped by tightening the packing follower nuts (key 20).

If the packing is relatively new and tight on the drive shaft (key 6), and if tightening the packing follower nuts does not stop leakage, it is possible that the drive shaft is worn or nicked so that a seal cannot be made. If the leakage comes from the outside

V150 & V300 Valves

diameter of the packing, it is possible that the leakage is caused by nicks, scratches, or corrosion on the packing box wall.

If the leakage cannot be stopped by the above steps, the packing must be removed and replaced. Inspect the drive shaft and packing box before installing new packing parts.

Packing Replacement

When replacing the packing, **the actuator should not be removed from the valve while the valve is still in the pipeline or between flanges.**

Valve/actuator adjustments must be made with the valve out of the pipeline.

Disassembly

1. Isolate the control valve from the line pressure, release pressure from both sides of the valve, and drain the process media from both sides of the valve. If using a power actuator, shut off all pressure lines to the power actuator, release pressure from the actuator, and disconnect the pressure lines from the actuator. Use lock-out procedures to be sure that the above measures stay in effect while you work on the equipment.
2. Remove line bolting, remove the control valve from the pipeline, and place the actuator/valve assembly on a protected flat surface with the seal protector ring facing up.
3. Remove the actuator cover. Note the orientation of the actuator with respect to the valve body and the lever orientation with respect to the valve drive shaft (see figure 8).



WARNING

When the actuator is removed from the valve, the ball/shaft assembly may suddenly rotate, resulting in personal injury. To avoid injury, carefully rotate the ball to the stable position after the actuator is removed.

CAUTION

When removing the actuator from the valve, do not use a hammer or similar tool to drive the lever or actuator off the valve shaft. Driving the lever or actuator off the valve shaft could damage the ball, seal, and valve.

If necessary, use a wheel puller to remove the lever or actuator from the valve shaft. It is okay to tap the wheel puller screw lightly to loosen the lever or actuator, but hitting the screw with excessive force could damage the ball, seal, and valve.

Note

Some actuator designs have a bolt inserted in the lever to spread the clamp on the valve spline shaft. Tightening the bolt expands the splined lever connection allowing the valve shaft to be removed.

4. When removing the lever (do not loosen the actuator turnbuckle adjustment), remove the actuator mounting screws and nuts (keys 23 and 24), and remove the actuator. (If necessary, refer to the actuator instruction manual for assistance.)
5. If necessary, remove the bonding strap assembly before attempting to remove the packing (see figure 4).
6. Remove the packing flange and nuts and packing follower (keys 20, 40, and 17).

If the valve is equipped with the ENVIRO-SEAL packing system, refer to the ENVIRO-SEAL Packing System for Rotary Valves instruction manual (form 5305) for disassembly.

7. Remove the packing parts (key 16 packing set includes additional key numbers) by making a formed wire hook with a sharp end. Pierce the rings with the sharp end of the hook in order to remove them. Do not scratch the drive shaft or packing box wall; scratching these surfaces could cause leakage. Clean all accessible metal parts and surfaces to remove particles that would prevent the packing from sealing. (Note: Metal packing parts are not provided in the packing set).

Assembly

If the valve is equipped with the ENVIRO-SEAL packing system, refer to the ENVIRO-SEAL Packing System Rotary Valves instruction manual (form 5305) for assembly.

1. Install the new packing parts using the parts sequence shown in figure 3.
2. Insert the packing follower and packing flange (keys 17 and 40) and secure them with the packing follower nuts (key 20). Tighten the nuts far enough to stop leakage during operating conditions.

Note

If the valve is equipped with a bonding strap assembly (figure 4), re-install the assembly.

3. Reconnect the actuator and lever in accordance with the orientations that were noted in step 3 of the disassembly procedures. If necessary, use figure 8 to identify the correct index marks.
4. If necessary, refer to the appropriate actuator instruction manual to complete actuator assembly and adjustment.
5. When the control valve is in operation, check the packing follower for leakage and retighten the packing follower nuts (key 20) as necessary.

Ball Seal Replacement

Perform this procedure if the control valve is not shutting off properly, or if seal inspection is necessary. Remove the actuator/valve assembly from the pipeline.

The actuator may remain mounted on the valve during the ball seal inspection and replacement procedures. Ball seal assembly details (with key numbers) are also shown in figure 5. Upon

inspection, if it is found that the ball, drive shaft, or bearings need to be replaced, use this procedure to remove the ball seal. Then, proceed to the Bearing and Ball Maintenance procedures to replace the ball, bearings, or shafts. Then return to this procedure and begin with the assembly steps in the Ball Seal Replacement section.

During disassembly and re-assembly procedures, handle the seal protector ring, seal, and other parts (keys 3, 11, 13, and 37) carefully to prevent damage. A new gasket (key 15) is required whenever the seal protector ring (key 3) is removed.

CAUTION

Due to the Vee-ball shape, take care to never rotate either the front skirted edge of the ball or the circular back edge of the ball through the ball seal at any time. The seal could be damaged.

The flow ring construction does not use a seal (key 11), radial seal (key 37), or wave spring (key 13). Use this procedure to remove the seal protector ring for flow ring constructions, but disregard any instructions calling for the seal and other seal parts.

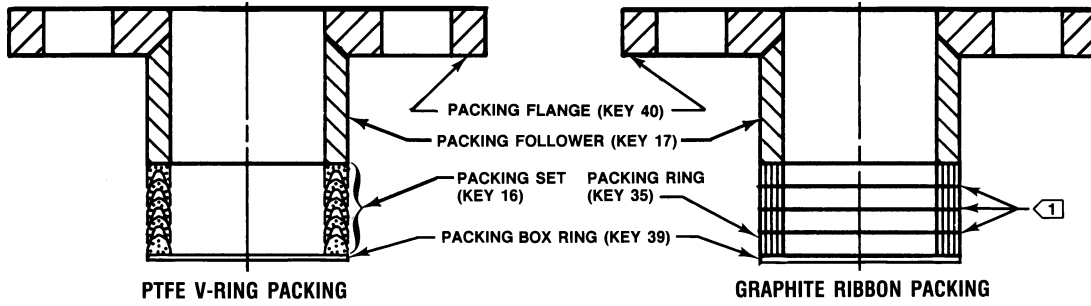

NOTES:
 1 INCLUDES ZINC WASHERS (KEY 36)
 FOR GRAPHITE RIBBON PACKING ONLY.

STANDARD PACKING ASSEMBLY

A6063/IL

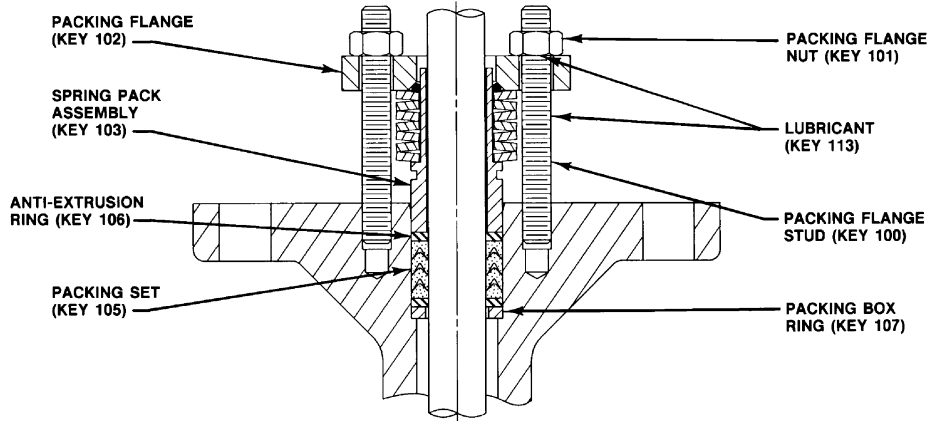

ENVIRO-SEAL PTFE PACKING SYSTEM

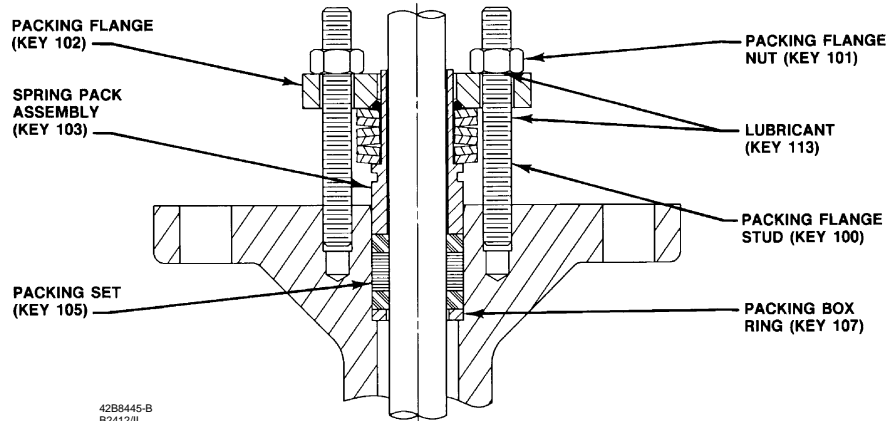

42B8445-B
 B2412/IL

ENVIRO-SEAL GRAPHITE PACKING SYSTEM

Figure 3. Packing Arrangements

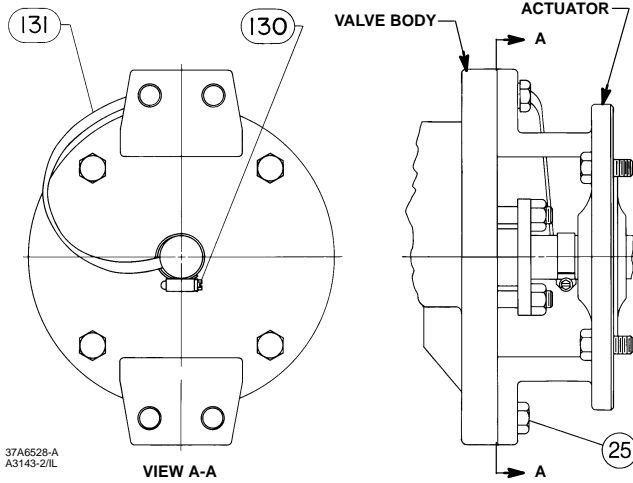

Figure 4. Optional Shaft-to-Body Bonding Strap Assembly

Disassembly



If the actuator is removed from the valve, the ball/shaft assembly may suddenly rotate, resulting in personal injury. To avoid injury, carefully rotate the ball to the stable position after the actuator is removed. If necessary, lock the ball in a specific position when directed by the following steps.

Key numbers are shown in figure 10, unless otherwise indicated.

1. Isolate the control valve from the line pressure, release pressure from both sides of the valve, and drain the process media from both sides of the valve. If using a power actuator, also shut off all pressure lines to the power actuator and release all pressure from the actuator.
2. Remove line bolting, remove the control valve/actuator assembly from the pipeline, and place the valve on a protected flat surface with the seal

protector ring facing up. Carefully rotate the ball to the open position.

Note

Lifting bolt holes are provided in the seal retainer or flow ring to assist in its removal from the valve body.

3. Remove the retainer screws (key 21). Carefully remove the seal protector ring and gasket (keys 3 and 15). (For flow ring constructions, go to step 4.)
 - a. **For valves with composition seal**, remove the seal (key 11) from the valve body (key 1).
 - b. **For valves with HD metal seal**, once the protector ring has been removed from the valve, push the metal seal (key 11) out of the seal protector ring (key 3). Remove the radial seal (key 37). Inspect, clean, or obtain replacement parts as necessary.

It might be necessary to remove the HD metal seal by carefully tapping it with a soft punch and hammer. Take care not to damage the seal protector ring surfaces.

4. Inspect, clean, or obtain replacement parts as necessary. Inspect the gasket and sealing surfaces on the valve body (key 1), ball (key 2), ball seal (key 11), and seal protector ring (key 3) for damage.
5. If a replacement ball, drive and follower shafts, or bearings (keys 2, 6, 9, and 10) are needed, proceed to the Bearing and Ball Maintenance procedure for disassembly and assembly procedures. If only the seal is to be replaced, proceed to the assembly procedure below.

Assembly

Refer to figure 5 for part and key number locations during seal installation.

1. Thoroughly clean all parts that are to be re-used or obtain replacement parts. Be sure that all sealing surfaces are in good condition without scratches or wear. If the valve has been installed between line flanges and the flange studs and nuts have been tightened, always replace the gasket (key 15).

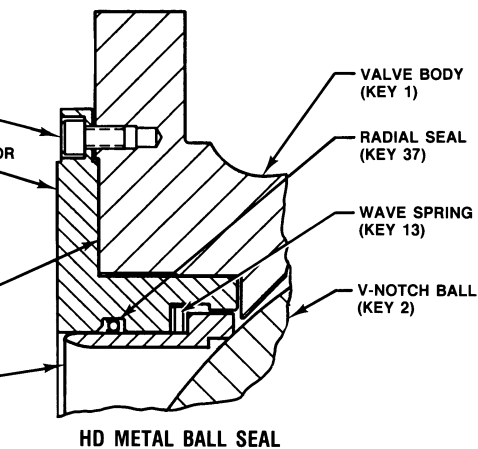
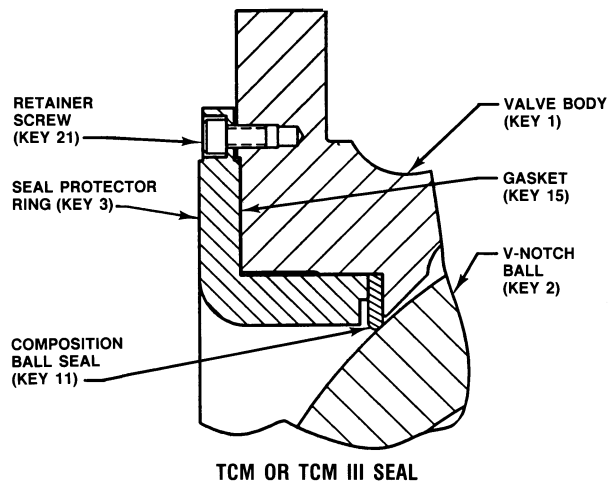

Figure 5. Ball Seal Assembly Detail

If you have not already done so, lift the valve and place it with the outlet flange face flat on the protected working surface. Use the lever from the actuator, or provide some other safe method to rotate the ball into the closed position. The inlet flange face should be up, and the ball approximately centered within the opening.

2. Make sure the ball cannot rotate during seal assembly procedures (read the **Warning** on page 9).

3. For valves with composition ball seals:

- Install the composition seal (key 11) into the valve body.
- Install the gasket (key 15) on the valve body.

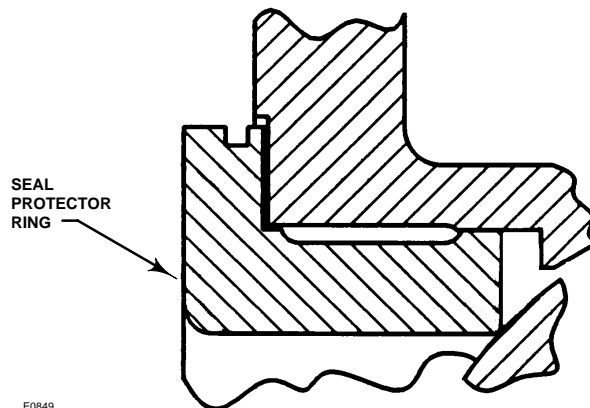

Figure 6. Flow Ring Construction

- Install the seal protector ring (key 3) into the valve body. (Go to step 6 below.)

4. For valves with HD metal seals:

- Lubricate with Mag Lub or an equivalent lubricant, and install the radial seal (key 37) into the appropriate groove in the seal protector ring making sure the open side of the radial seal faces away from the ball.
- Install the wave spring (key 13) on the seal protector ring (key 3).
- Install the HD metal seal (key 11) into the seal protector ring (key 3), past the radial seal. While pushing it past the radial seal, make sure the HD metal seal is level.
- To assist with break-in of the HD metal seals, it is recommended that the ball and seal be lubricated. Apply Dow Corning 321 dry film lubricant or equivalent to the seat of the HD metal seal (key 11) and to the face of the ball.

Note

During break-in, if the Vee-Ball rotation is not smooth, it may be necessary to tighten the packing slightly to dampen any tendency for stick-slip motion of the ball and seal assembly.

5. Install the HD metal ball seal/seal protector ring assembly into the valve body (key 1). Go to step 6 below.
6. Install the retaining screws (key 21) that secure the seal protector ring (key 3) to the valve body (key 1). Tighten the screws (key 21).

7. If necessary, refer to the Packing Maintenance procedures to install the packing. Install the actuator using the Actuator Mounting procedures or to the appropriate actuator instruction manual.

Bearing and Ball Maintenance

Procedures for disassembly and assembly of the bearings and ball cannot be accomplished until the ball seal and valve packing are loosened.

- Refer to the Packing Maintenance procedures to remove the actuator.
- Refer to the Ball Seal Replacement procedures to remove the seal from the valve.
- Install an “eye” bolt into the threaded hole within the ball cavity (see figure 10). (Note: The eye bolt provides a method for lifting and controlling the rotation of the ball during the following procedures. (Read the following **Warning**.)
- When ball seal disassembly steps are complete, return to this section.

If you have not already done so, place the valve on a flat protected working surface with the seal side down, prior to removing and installing the ball and bearings. Key numbers in this procedure are shown in figure 10, unless otherwise indicated.

Disassembly



When the actuator is removed from the valve, the ball may suddenly rotate, resulting in personal injury. To avoid injury, carefully rotate the ball to a stable position.

Once the drive and follower shafts have been removed from the valve body, the ball may fall out of or into the valve body. To avoid personal injury or damage to the sealing surfaces of the ball, provide a hoist to support the ball to prevent it from falling as the shafts are being removed.

1. Carefully lift the valve and set it on the edge of the flanges so the ball is in the open position, and in the down position. (Note: The weight of the ball should turn it into the open position.) Block the drive

end of the valve body to hold the shaft in a horizontal position.

2. Drive the pins (key 7) out of the drive shaft and out of the follower shaft (keys 6 and 9).

Both pins are tack welded to the ball ears. To remove a pin, insert a pin punch into the open hole, opposite the tack welded side, and break the tack weld while driving the pin out.

3. Carefully lift the valve and place the valve on the working surface with the seal side down (read the **Warning** above).

Because of the weight of the ball, it should rotate so the contoured sealing surface of the ball is resting on the surface.

4. Remove the flange nuts (key 47), the bottom flange (key 44), and gasket (key 45) from the valve. Use a hoist to lift valve body slightly.

Make sure the sealing surface of the ball is not damaged while removing the follower shaft (key 9).

5. Push the follower shaft (key 9) into the center of the ball. For valves with metal bearings, remove the thrust washer (key 38).

6. Pull the drive shaft (key 6) out of the actuator side of the valve body. For valves with metal bearings, remove the thrust washer (key 38).

7. Removing the bearings (key 10):

a. **For PEEK bearings**, remove the bearings by hand. If the bearings are tight in the valve body, pull or drive them out with a slight pressure.

b. **For metal bearings**, use a press and ram to remove the drive shaft bearings out of the valve body. Refer to figure 7 for ram dimensions.

- To remove the follower shaft bearing from the bottom flange (key 44), use a blind-hole bearing puller similar to CG2545AB, which is made by Snap-on Tools. If you do not have such a tool, you can machine the bearing out of the bottom flange.

Note

For proper shutoff performance, the ball and seal require the bearing (key 10) to be positioned correctly. If you removed the bearings (key 10), be sure to locate the new bearings as shown in figure 7.

8. Thoroughly clean all surfaces of parts that are to be re-used or obtain replacement parts. Upon reassembly, the pins needs to be tack welded to the

V150 & V300 Valves

ball ears. Remove excess weld material, if the parts are to be used during re-assembly.

Assembly

1. Inspect all sealing surfaces to ensure they are in good condition and without scratches or wear. Thoroughly clean all parts and make sure they are free of oil or grease.

2. Installing bearings (key 10):

a. **For PEEK bearings**, install the drop-in bearings by hand. The bearing flanged end should touch the drive shaft bearing support surface (see figure 10). Also, install the bearing (key 10) into the bottom flange (key 44). The bearing flange should touch the surface of the bottom flange.

b. For metal bearings (key 10):

- For the valve body, use a press and ram to install the bearings. Refer to figure 7 for dimensions and tolerances of the ram and bearings.

- Press the bearing in until it is flush with the valve body (key 1).

The acceptable tolerance for bearing location is: flush with the valve body to 1.5 mm (0.06 inches) inside the bearing bore. That is, the bearings should not protrude into the flow cavity of the valve.

- Press the bearing into the bottom flange, using the same tolerances shown for bearing installation into the valve body.



WARNING

The ball might be damaged if it is allowed to fall into the valve body. To avoid personal injury or damage to the sealing surfaces, support the ball to prevent it from falling into the valve body cavity.

3. Installing the ball, drive and follower shafts (keys 2, 6, and 9):

- If you have not already done so, place the valve body (key 1) on a flat protected working surface with the seal side flat on the working surface.

- In the the next step, make sure the splined ear of the ball is aligned with the packing box side of the valve body.

CAUTION

The ball might be damaged if it is allowed to hit the flange edge or interior of the valve cavity while it is being lowered into the valve body.

- Using the “eye” bolt in the center of the ball cavity, lift the ball above the valve. Carefully, start lowering the ball, splined ear first, down into the valve body through the outlet flange. When the ball ear enters the valve body, it needs to be misaligned with the drive shaft bearing support.

As the ball clears the outlet opening, turn and rotate the ball as necessary to align the splined ball ear with the drive shaft bearing support (see figure 10).

Allow the ball to come to rest on the contoured sealing surface of the ball on the protected surface.

4. Carefully lift the valve body until the drive shaft (key 6) can be inserted through valve shaft bore and bearing (key 10), and into the drive shaft/splined ear of the the ball.

Note

1. See note 1, figure 10.

2. For valves with metal bearings, hold the thrust washer (key 38, figure 10) in place before inserting the drive shaft.

Make sure that the “O” mark on the shaft aligns with the “O” mark on the ball ear, within the ball cavity. Insert the drive shaft (key 6) into the ball. If the “O” marks are aligned correctly, the drive shaft pin (key 7) should slide through the ball ear and drive shaft.

- With the valve body still lifted, align the ball follower shaft bore with the opening in the valve body for the lower flange (key 44). [Note: For valves with metal bearings, hold the thrust washer (key 38, figure 10) in place before inserting the follower shaft.] While aligning the pin holes, insert the follower shaft into the ball.

- Place the gasket (key 45) in position on the bottom flange (key 44). Insert the bottom flange into the valve body, onto the follower shaft, and thread the bottom flange nuts (key 47) onto the studs (key 46). Hand tighten the nuts.

Bearing Ram Dimensions

VALVE SIZE, INCH	RAM LENGTH		RAM DIAMETER			
	L		D		d	
	mm	Inch	mm	Inch	mm	Inch
14	172	6.75	51.30	2.02	44.45	1.75
			51.05	2.01	44.20	1.74
16	178	7.00	60.96	2.40	53.91	2.125
			60.71	2.39	53.72	2.115
20	216	8.50	70.35	2.77	63.50	2.50
			70.10	2.76	63.25	2.49

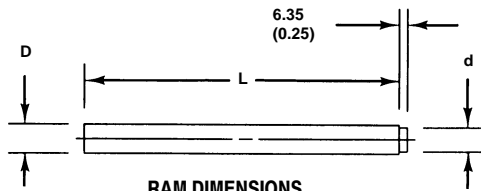

RAM CONSTRUCTION DETAIL

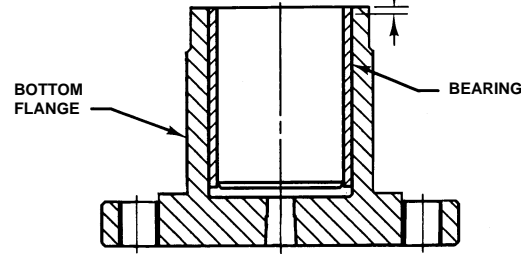
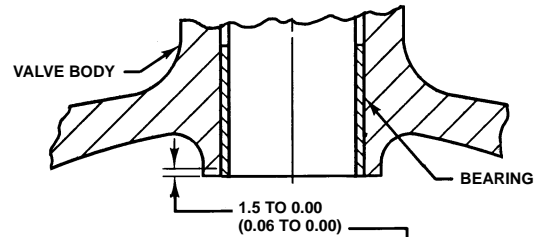

METAL BEARING INSTALLATION

mm
(INCHES)

Figure 7. Ram Construction and Bearing Installation

5. Installing the pins (key 7):

CAUTION

The ball might be damaged if it is allowed to hit the flange edge or interior of the valve cavity while it is being lowered into the valve body.

- Lift the valve and place it on the edge of both flanges. Make sure the ball is in its open position, and in the lower half of the valve cavity. Block the packing box side of the valve so the drive shaft is horizontal.
- Insert the pin (key 7) into the ball ear and follower shaft until it is flat with the ball ear surface. (Note: the pin does not extend the full width of the ball ear.)
- Refer to the Packing Replacement procedures and install the packing parts as described in that section. Slightly tighten the packing nuts (key 20).
- Using a pry bar, insert the bar between the ball ear and the follower shaft side of the valve body. Move the ball tightly towards the packing box side of the valve body, and against the bearing flange or thrust washer. The ball should be centered within the seal cavity.

- Again, insert the bar between the ball ear and the follower shaft side of the valve body. While holding the ball in place, tighten the packing box nuts (key 20).

If the ball is **not** held in place while tightening the packing box nuts, the ball will move to an off-center position.

6. Welding the pins (key 7):

Note

When welding the pins to the ball ears, use a compatible filler rod material. For CG8M (317 stainless steel) balls use a 309 or 309L filler rod.

Tack weld both pins (key 7) to the ball ears with a 10 mm (3/8-inch) diameter weld. (Note: Good weld penetration is required on both the pin and ball ear.)

7. Tighten the bottom flange nuts using the following torque values: For 14-inch valves, 102 N•m (75 lbf•ft); for 16-inch valves, 141 N•m (104 lbf•ft); and for 20-inch valves, 176 N•m (130 lbf•ft).

8. Lift the valve and place it with the outlet flange face flat on the protected working surface. Use the lever from the actuator, or provide some other safe method to rotate the ball into the closed position. The inlet flange face should be up to allow the installation of the ball seal. The ball should be centered within the valve opening.

9. Refer to the Ball Seal Replacement procedures to install the ball seal and seal protector ring.

V150 & V300 Valves

ACTUATOR		VALVE OPEN	ACTUATOR POSITION			
MOUNTING	STYLE		1	2	3	4
(STANDARD) RIGHT-HAND	STYLE A PUSH DOWN TO CLOSE					
	STYLE B PUSH DOWN TO OPEN					
(STANDARD) LEFT-HAND	STYLE C PUSH DOWN TO OPEN					
	STYLE D PUSH DOWN TO CLOSE					
(OPTIONAL) LEFT-HAND	STYLE C PUSH DOWN TO CLOSE					
	STYLE D PUSH DOWN TO OPEN					

NOTE:
1. ARROW ON LEVER INDICATES DIRECTION OF ACTUATOR THRUST TO CLOSE VALVE.

Figure 8. Index Mark for Actuator Lever Orientation

Actuator Mounting

Standard flow direction is with the seal protector ring (key 3) facing upstream. Install the valve with the drive shaft horizontal and the ball closing in the downward direction (see figure 8).

Actuator travel must be adjusted before installing the valve in the pipeline because it is **not** possible to accurately determine the closed position once the valve is in the line.

The actuator can be right or left-hand mounted in any of four positions as shown in figure 8.

WARNING

The Vee-ball (key 2, figure 10) closes with a cutting motion. To avoid personal injury, keep hands, tools, and other objects away from the ball while stroking the valve.

Note

Right-hand mounting—Actuator is on the right side of the valve when viewed from the valve inlet.

Left-hand mounting—Actuator is on the left side of the valve when viewed from the valve inlet.

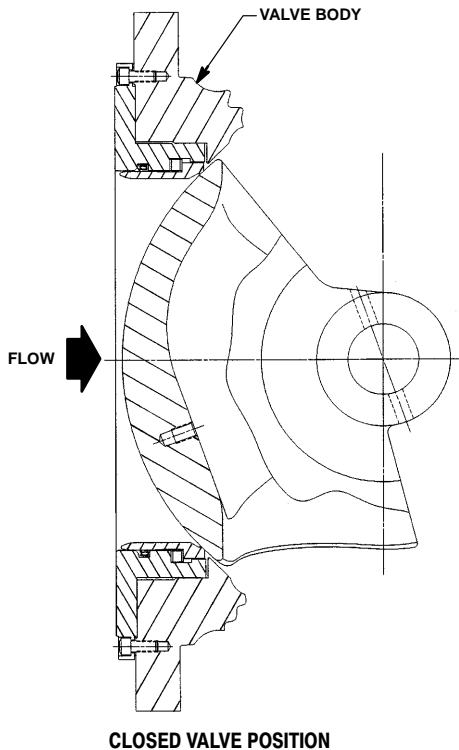
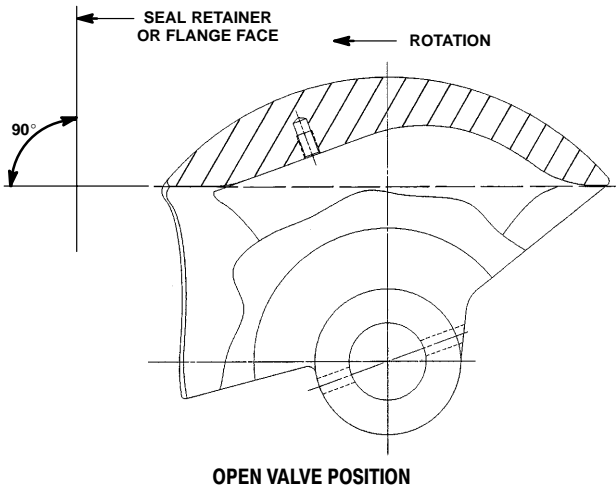

A6065/IL

Figure 9. Determining the Ball Position

However, when changing the valve from right to left-hand mounting, or vice versa, a different valve drive shaft and ball are required. If a new shaft and ball are required, refer to the Bearing and Ball Maintenance section and the Parts List in this manual.

Note

If necessary, it is possible to mount the valve in the left-hand position with the ball rotating to the top of the valve. This will require a non-standard ball. The ball rotates clockwise to close. Refer to figure 8, or contact your Fisher sales office for assistance.

Determining Open Position

The valve must be removed from the pipeline to check the position of the ball.

1. Rotate the ball to the open position. The open position of the ball is shown in figure 9.
2. Adjust the actuator linkage until the open position is obtained using the appropriate actuator instruction manual procedures.
3. Stroke the valve to the closed position.

Make sure the actuator does not stroke the ball more than 90 degrees when rotating to the closed position (see figure 9).

Note

Fisher does not assume responsibility for the selection, use, or maintenance of any product. Responsibility for proper selection, use, and maintenance of any Fisher product remains solely with the purchaser and end-user.

V150 & V300 Valves

Parts Ordering

A serial number is assigned to each valve and stamped on the nameplate. Always refer to the valve serial number when corresponding with your Fisher sales office regarding spare parts or technical information. When ordering replacement parts, also specify the complete 11-character part number from the Parts List.

Components that are not manufactured by Fisher should not, under any circumstances, be used in any Fisher valve. The use of parts not manufactured by Fisher may adversely affect the performance of the valve as well as worker and workplace safety.

Parts List

Note

Part numbers are shown for recommended spares only. For part numbers not shown, contact your Fisher Sales office.

Key	Description	Part Number
1	Valve Body Assembly If a part number is required, contact your Fisher sales office.	
2	Ball	
3	Seal Protector Ring	
6	Drive Shaft	
7*	Pin, S20910 (2 req'd)	
	14-inch	13B6896X012
	16-inch	13B0697X012
	20-inch	13B6060X012
9	Follower Shaft	
10*	Bearing (2 req'd)	See following table
11*	Ball Seal	See following table
13*	Wave Spring, N07750 (Inconel) Use w/HD Metal Seal	
	14-inch	23B7013X012
	16-inch	23B0695X012
	20-inch	23B6064X012
15*	Gasket, laminated graphite Standard Construction	
	14-inch	13B6894X022
	16-inch	13B0692X022
	20-inch	13B6058X022
	Use w/ oxygen service	
	14-inch	13B6894X032
	16-inch	13B0692X032
	20-inch	13B6058X032
16*	Packing Set, Set includes PTFE V-ring packing with one carbon-filled conductive ring, Male adapter, and female adapter	
	14-inch	12A9057X022
	16-inch	1R5162X0012
	20-inch	1R6699X0012
17	Packing Follower	
19	Packing Follower Stud (2 req'd)	
20	Packing Follower Nut (2 req'd)	

Key	Description	Part Number
21	Retainer Screw, (used w/B8M)	
23	Actuator Mounting Screw (4 req'd)	
24	Actuator Mounting Nut, stainless steel (4 req'd)	
25	Pipe Plug	
26	Identification Nameplate	
27	Drive Screw	
28	Flow Arrow (2 req'd)	
30	Body Size/Serial Number Nameplate,	
31	Nameplate Wire (not shown)	
35*	Packing Ring, graphite ribbon (4 req'd)	
	14-inch	12A9140X032
	16-inch	1V949601652
	20-inch	12A9142X012
36*	Packing Washer, zinc (Use w/graphite ribbon packing, 3 req'd)	
	14-inch	14A9772X012
	16-inch	12B5927X012
	20-inch	14A9774X012
37*	Radial Seal, PTFE/CG/N10276 (alloy 276C) Use w/HD Metal Ball Seal	
	14-inch	13B7012X012
	16-inch	13B0696X012
	20-inch	13B6065X012
38	Thrust Washer (4 req'd)	
39	Packing Box Ring	
40	Packing Flange	
44	Bottom Flange	
45*	Gasket, S31603 (316L SST)	
	V150	
	14-inch	13B6895X012
	16-inch	13B0690X012
	20-inch	13B6059X012
	V300	
	14-inch	14B5575X012
	16-inch	14B5354X012
46	Bottom Flange Stud (6 req'd)	
47	Hex Nut (6 req'd)	

ENVIRO-SEAL Packing System (figure 3)

100	Packing Flange Stud	
101	Packing Flange Nut	
102	Packing Flange	
103	Spring Pack Assembly	
105*	Packing Set	
	PTFE	
	14-inch	14B3049X012
	16-inch	14B3203X012
	20-inch	14B3060X012
	Graphite	
	14-inch	13B8816X152
	16-inch	13B8816X182
	20-inch	13B8816X162
106*	Anti-Extrusion Ring (2 req'd)	
	14-inch	14B3045X012
	16-inch	14B3199X012
	20-inch	14B3056X012
107*	Packing Box Ring	
	14-inch	12A9058X012
	16-inch	12B3373X012
	20-inch	12A9084X012
111	Tag	23B6562X012
112	Tie Cable	18A9401X012
113	Lubricant	

Instruction Manual

Form 5316
July 2002

V150 & V300 Valves

Key 10* Bearing (2 req'd)

VALVE SIZE, INCHES	BEARING MATERIAL			
	PEEK ⁽¹⁾ /PTFE	S44004	Alloy 6B	Silver Plated Alloy 6B
14	14B3651X012	14A6551X012	14A6552X012	14A6540X012
16	14B3653X012	13B7124X012	13B7124X022	13B7125X012
20	14B3655X012	14A6555X012	14A6556X012	14A6542X012

1. PEEK stands for poly-ether-ether-ketone.

Key 11* Ball Seal

VALVE SIZE, INCHES MATERIAL	COMPOSITION FORWARD FLOW ONLY		HEAVY DUTY METAL SEAL		
	TCM Plus	TCM Ultra	CF10SMnN	CD7MCuN	Alloy 6B
14	13B6897X032	13B6897X042	33B7010X012	33B7010X022	33B7010X032
16	1V6298X0022	1V6298X0032	33B0693X012	33B0693X022	33B0693X032
20	13B6061X032	13B6061X042	33B6062X012	33B6062X022	33B6062X032

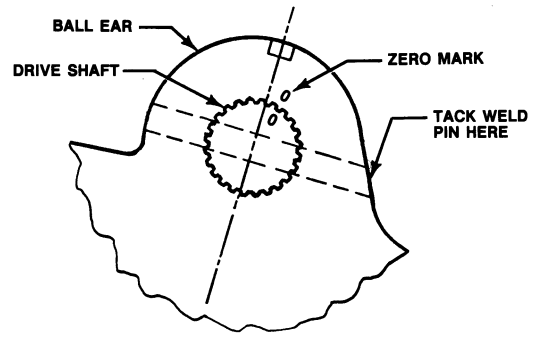
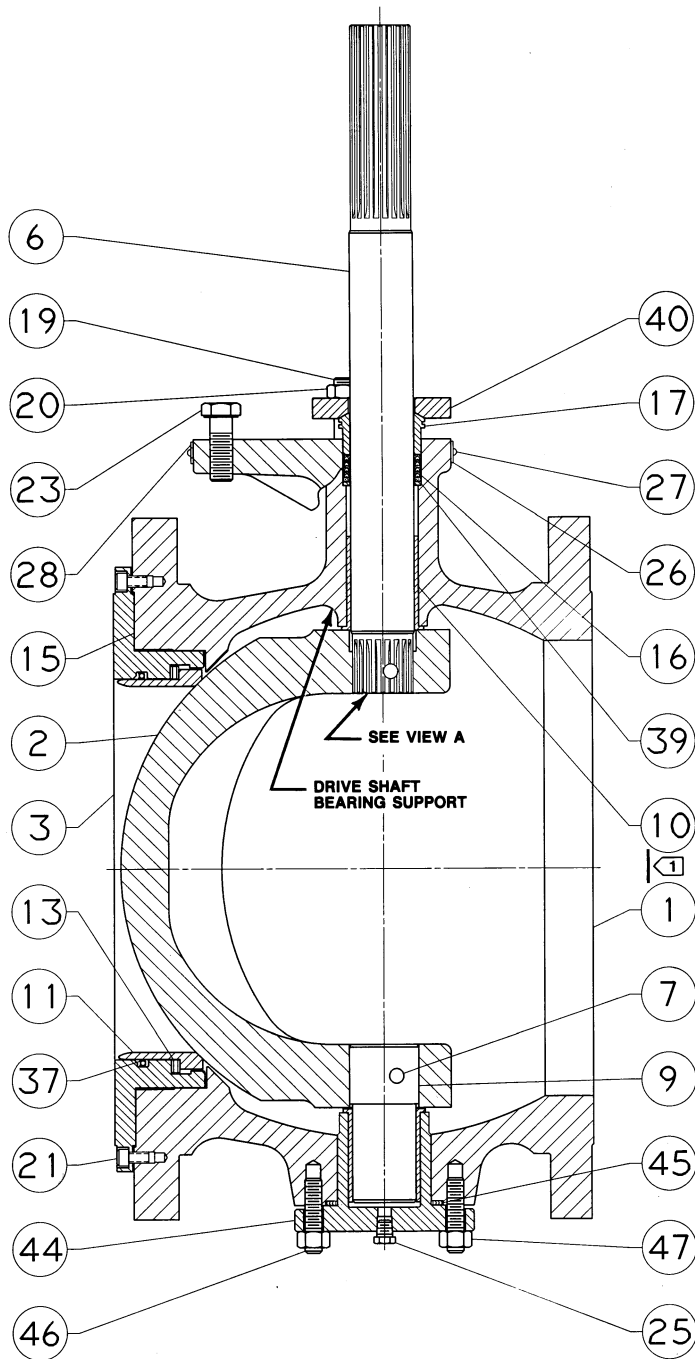

43B6886-A/DOC

VIEW A

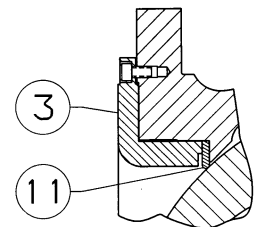

COMPOSITION SEAL

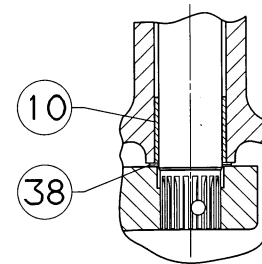

METAL BEARING

NOTES:

1 THE V-NOTCH BALL EXTENDS TO THIS POINT WHEN ROTATED 180° AWAY FROM THE CLOSED POSITION. SEE BEARING AND V-NOTCH BALL ASSEMBLY PROCEDURES.

2. KEYS 24, 30, 31, 35 AND 36 ARE NOT SHOWN.

43B7128-A/DOC

Figure 10. Design V150 and V300 Valve Assembly

ENVIRO-SEAL, e-disc, Vee-Ball and Fisher are marks owned by Fisher Controls International, Inc., a business of Emerson Process Management. The Emerson logo is a trademark and service mark of Emerson Electric Co. All other marks are the property of their respective owners. This product may be covered under one or more of the following patents: 5,129,625; 5,131,666; 5,056,757; 5,230,498; and 5,299,812 or under pending patents.

The contents of this publication are presented for informational purposes only, and while every effort has been made to ensure their accuracy, they are not to be construed as warranties or guarantees, express or implied, regarding the products or services described herein or their use or applicability. We reserve the right to modify or improve the designs or specifications of such products at any time without notice.

Fisher does not assume responsibility for the selection, use or maintenance of any product. Responsibility for proper selection, use and maintenance of any Fisher product remains solely with the purchaser and end-user.

Emerson Process Management

Fisher

Marshalltown, Iowa 50158 USA

Cernay 68700 France

Sao Paulo 05424 Brazil

Singapore 128461

www.Fisher.com

