

February 2010

# Y695A Series Vapor Recovery Regulators

## Introduction

### Scope of the Manual

This manual provides instructions for installation, startup, maintenance, and parts information for the Y695A Series vapor recovery regulators. Instructions and parts lists for other equipment used with these regulators are found in separate manuals.

### Specifications

Specifications for the Y695A Series vapor recovery regulators are listed on page 2. Specifications for a given regulator as it originally comes from the factory are stamped on the nameplate.

### Product Description

The Y695A Series vapor recovery regulators are direct-operated. They are used to sense an increase in vessel pressure and vent excessive internal vessel pressure to an appropriate vapor recovery disposal or reclamation system. They may also be used as backpressure regulators or relief valves.

**Type Y695A**—The Type Y695A has internal registration requiring no downstream control line.

**Type Y695AM**—The Type Y695AM has a blocked throat and a downstream control line connection for external registration.

### Principle of Operation

The Y695A Series vapor recovery regulators are used to maintain a constant inlet (blanket) pressure with the outlet flowing to a system whose pressure is lower than that at the inlet. When vessel pressure increases above the setpoint of the regulator due to pumping in or thermal heating, the force of the control spring is overcome by pressure acting on the diaphragm. This moves the disk away from the orifice, allowing gas to flow from the vessel to the vapor recovery system. As vessel pressure is reduced, the force of the back disk spring causes the disk to move toward the orifice, decreasing the flow of gas out of the vessel. As vessel pressure drops below the setpoint of the regulator, the disk will seat against the orifice, shutting off the gas flow.

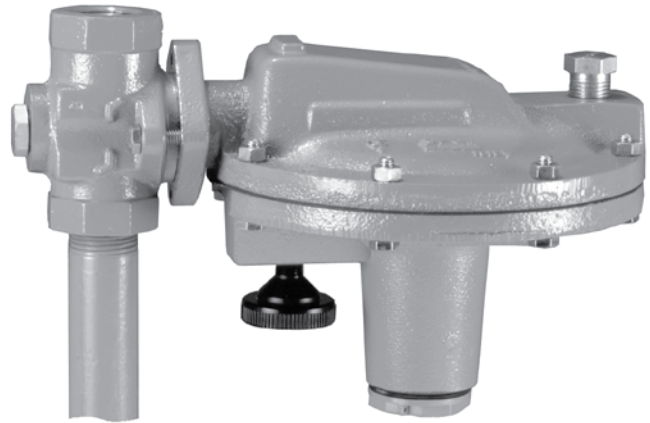

Figure 1. Type Y695A Vapor Recovery Regulator

## Installation

### WARNING

**Personal injury, property damage, equipment damage, or leakage due to escaping gas or bursting of pressure-containing parts may result if this regulator is overpressured or is installed where service conditions could exceed the limits given in the Specifications, or where conditions exceed any ratings of the adjacent piping or piping connections.**

**To avoid such injury or damage, provide pressure-relieving or pressure-limiting devices (as required by the appropriate code, regulation, or standard) to prevent service conditions from exceeding those limits. Additionally, physical damage to the regulator could cause personal injury or property damage due to escaping gas. To avoid such injury or damage, install the regulator in a safe and well ventilated location.**

# Y695A Series

## Specifications

<p><b>Body Size</b> NPS 3/4 or 1 (DN 20 or 25)</p> <p><b>End Connection Styles</b> See Table 2</p> <p><b>Maximum Allowable Inlet (Casing) Pressure<sup>(1)</sup></b> 150 psig (10,3 bar)</p> <p><b>Maximum Outlet Pressure<sup>(1)</sup></b> 150 psig (10,3 bar)</p> <p><b>Maximum Emergency Inlet Pressure to Avoid Internal Parts Damage</b> 150 psig (10,3 bar)</p> <p><b>Control Pressure Ranges<sup>(1)</sup></b> See Table 1</p> <p><b>Orifice Size</b> 7/16-inch (11 mm)</p>	<p><b>Temperature Capabilities<sup>(1)</sup></b></p> <p><b>Nitrile (NBR):</b> -20° to 180°F (-29° to 82°C)</p> <p><b>Fluorocarbon (FKM):</b> 40° to 300°F (4° to 149°C)</p> <p><b>Perfluoroelastomer (FFKM):</b> -20° to 300°F (-29° to 149°C)</p> <p><b>Ethylene propylene (EPDM):</b> -20° to 300°F (-29° to 149°C)</p> <p><b>Spring Case Vent Connection</b> 1/4 NPT</p> <p><b>Diaphragm Case Connection</b> 1/2 NPT</p> <p><b>Approximate Weight</b> 19 pounds (9 kg)</p>
---	---

1. The pressure/temperature limits in this Instruction Manual and any applicable standard or code limitation should not be exceeded.

**Table 1. Control Pressure Ranges (Spring, Key 6)**

RELIEF SET PRESSURE RANGE	SPRING PART NUMBER	SPRING COLOR	SPRING WIRE DIAMETER, INCHES (mm)	FREE LENGTH, INCHES (mm)
2 to 7-inches w.c. (5 to 17 mbar) <sup>(1)(2)</sup>	1B653827052	Red	0.08 (2,2)	3.62 (92)
3 to 13-inches w.c. (7 to 32 mbar) <sup>(1)(2)</sup>	1B653927022	Olive drab	0.10 (2,7)	3.75 (95)
10 to 26-inches w.c. (25 to 65 mbar)	1B537027052	Yellow	0.11 (2,9)	4.18 (106)
0.9 to 2.5 psig (0,06 to 0,17 bar)	1B537127022	Light green	0.15 (4,0)	4.06 (103)
1.3 to 4.5 psig (0,09 to 0,31 bar)	1B537227022	Light blue	0.18 (4,7)	3.94 (100)
3.8 to 7 psig (0,26 to 0,48 bar)	1B537327052	Black	0.21 (5,5)	3.98 (101)

1. Spring ranges based on spring case installed pointed down. When installed pointing up, the spring ranges increase by 2-inches w.c. (5 mbar).  
2. Do not use Fluorocarbon (FKM) diaphragm with these springs at diaphragm temperatures lower than 60°F (16°C).

- Use only qualified personnel when installing, operating, and maintaining the regulators. Before installing, inspect the regulators for any shipment damage or foreign material that may have collected during crating and shipment. Make certain the body interior is clean and the pipelines are free of foreign material. Apply pipe compound only to the male pipe threads.
- Install the regulator using a straight run of pipe the same size or larger as the regulator body. Flow through the regulator body is indicated by the flow arrow attached to the body. If a block valve is required, install a full flow valve between the regulator and the blanketed vessel. For proper operation, the regulators should be installed with the spring case barrel pointed down. Key numbers referenced in this section are shown in Figures 3, 4, and 5.

**regulator in hazardous gas service to a remote, safe location away from air intakes or any hazardous location. The vent line or stacking must be protected against condensation or clogging.**

- To keep the spring case vent from being plugged or the spring case from collecting moisture, corrosive chemicals, or other foreign material, point the vent down or otherwise protect it. To remotely vent the regulator, remove the vent (key 26) and install obstruction-free tubing or piping into the 1/4 NPT vent. Provide protection on a remote vent by installing a screened vent cap into the remote end of the vent pipe. If continuous operation of the system is required during inspection or maintenance, install a three-way bypass valve around the regulator.
- Vapor recovery regulators are used to maintain a constant inlet (blanket) pressure with the outlet flowing to a system whose pressure is lower than that at the inlet. The recovery regulators are not intended to be used as an ASME certified relief device for overpressure protection on a tank. They are to be used as part of a gas blanketing system to control the outflow of blanketing gas under normal conditions



### WARNING

**A regulator may vent some gas to the atmosphere. In hazardous or flammable gas service, vented gas may accumulate, and cause personal injury, death, or property damage due to fire or explosion. Vent a**

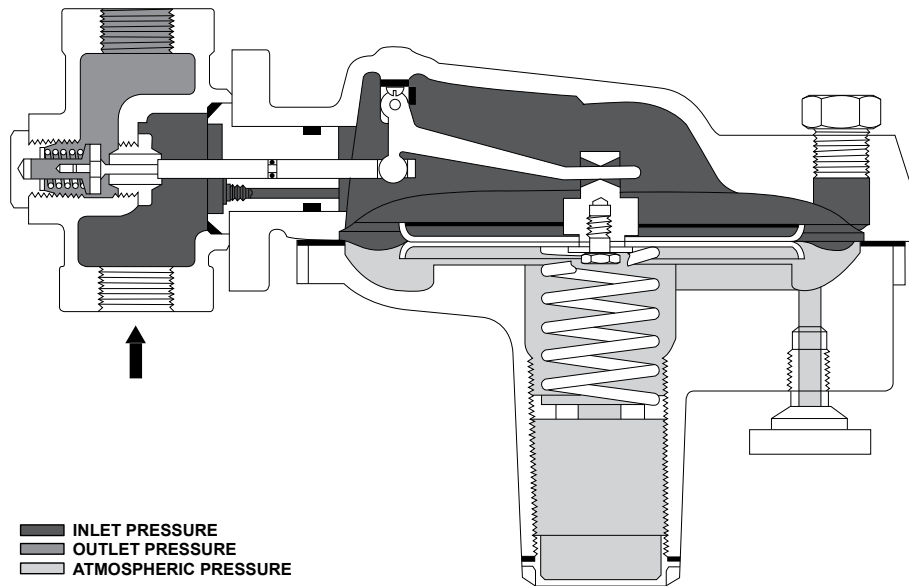

B2648

**Figure 2.** Type Y695A Operational Schematic

and to collect tank vapors for the vapor disposal reclamation system. You should provide alternate methods of emergency overpressure protection.

## Startup and Adjustment



### WARNING

**To avoid personal injury, property damage, or equipment damage caused by bursting of pressure containing parts or explosion of accumulated gas, never adjust the control spring to produce an outlet pressure higher than the upper limit of the outlet pressure range of that particular spring (see Table 1). If the desired outlet pressure is not within the range of the control spring, install a spring of the proper range according to the Diaphragm and Spring Case Area section of the maintenance procedure.**

With installation completed, the regulator can be placed in operation by slowly opening the upstream and downstream block valves, if used, while using gauges to monitor pressure. The regulator has been adjusted at the factory to provide approximately the pressure requested. The range of allowable pressure settings is stamped on the nameplate. If a pressure setting beyond the stamped range is required, install a spring with the desired range by following the procedures for changing the spring in the Maintenance section. To adjust the pressure setting, perform the following steps (key numbers are referenced in Figures 3 and 5):

1. Remove the closing cap (key 22).
2. Turn the adjusting screw (key 35) either clockwise to increase control pressure or counterclockwise to

decrease control pressure. The regulator will go into immediate operation. To ensure correct operation always use a pressure gauge to monitor the vapor recovery pressure when making adjustments.

3. Replace the closing cap (key 22).

## Shutdown

First close the nearest upstream shutoff valve and then close the nearest downstream shutoff valve to vent the equipment properly. Next, open the vent valves on both the upstream and downstream sides of the regulator. All pressure between the shutoff valves is released through the open vent valves.

## Maintenance

Regulator parts are subject to normal wear and must be inspected and replaced as necessary. The frequency of inspection and replacement of parts depends upon the severity of service conditions or the requirements of local, state, and federal regulations. Due to the care Fisher® takes in meeting all manufacturing requirements (heat treating, dimensional tolerances, etc.), use only replacement parts manufactured or furnished by Fisher.



### WARNING

**To avoid personal injury, property damage, or equipment damage caused by sudden release of pressure, isolate the regulator from all pressure and cautiously release trapped pressure from the regulator before attempting disassembly.**

# Y695A Series

---

## Body Area

This procedure is for gaining access to the disk assembly, orifice, and body seal O-ring. All pressure must be released from the regulator, before the following steps can be performed. Key numbers are referenced in Figures 3, 4, and 5.

1. To inspect and replace the disk assembly (key 13) remove the body cap assembly (key 43).
2. Remove the disk assembly (key 13) from the disk spacer (key 44) and replace if necessary.
3. To inspect the orifice (key 5, Figures 3 and 5) on Types Y695A and Y695AM or throat seal (key 31, Figure 5) and machine screw (key 33, Figure 5) on the Type Y695AM, remove the cap screws (key 2) and separate the diaphragm case assembly (key 4) from the body (key 1).
4. Remove and inspect the body seal O-ring (key 11) and the backup ring (key 49). Replace if damaged.
5. For a Type Y695AM (Figure 5), inspect the throat seal O-ring (key 31) by removing the machine screw (key 33). Replace if necessary. To install a throat seal, place the O-ring on the machine screw and thread into guide insert (key 18) to seal.
6. Inspect and replace the orifice (key 5) if necessary. Lightly lubricate the threads of the replacement orifice. Install with 29 to 37 foot-pounds (39 to 50 N•m) of torque.
7. Install the backup ring (key 49) into the body (key 1). Next place the body seal O-ring (key 11) into the body. See Figure 5.

### Note

**In the following step, be sure to install the spring case barrel pointed down as shown in Figure 1.**

8. Replace the diaphragm casing (key 4) on the body (key 1) and secure with the cap screws (key 2) using 7 to 9 foot-pounds (9,5 to 12 N•m) of torque.
9. Secure the disk assembly (key 13) to the disk spacer (key 44). Place the back disk spring (key 41) and a new back body seal O-ring (key 42) on the back body cap (key 43).
10. Lightly lubricate the threads when replacing the body cap assembly.

## Diaphragm and Spring Case Area

This procedure is for gaining access to the control spring, diaphragm, and lever assembly stem. All pressure must be released from the diaphragm case assembly before performing the following steps. Key numbers are referenced in Figures 3, 4, and 5.

### To Change the Control Spring:

1. Remove the closing cap (key 22), and turn the adjusting screw (key 35) counterclockwise to remove all compression from the control spring (key 6).
2. Remove the adjusting screw (key 35) and change the control spring to match the desired spring range.
3. Install the adjusting screw (key 35) and follow steps 1 through 3 of the Startup and Adjustment section.
4. Install a replacement closing cap gasket (key 25), if necessary, and reinstall the closing cap (key 22).
5. If the spring range was changed, be sure to change the stamped spring range on the spring case nameplate.

### To Disassemble and Reassemble Diaphragm Parts:

Use this procedure to gain access to the control spring, diaphragm assembly, valve stem, and stem O-ring. All pressure must be released from the diaphragm case assembly before performing these steps. Key numbers are referenced in Figures 3, 4, and 5.

1. Remove the closing cap (key 22) and the adjusting screw (key 35).
2. Remove the hex nuts (key 23, not shown) and cap screws (key 24), lift off the spring case assembly (key 3) and remove the control spring (key 6).
3. Remove the diaphragm (key 10) plus attached parts by tilting them so that the pusher post (key 8) slips off the lever assembly (key 16). To separate the diaphragm assembly (key 10) from the attached parts, unscrew the diaphragm plate cap screw (key 38) from the pusher post (key 8). If the only further maintenance is to replace the diaphragm parts, skip to step 7.
4. To replace the lever assembly (key 16), remove the machine screws (key 17). To replace the stem (key 14) or stem O-ring (key 30), perform Body Area Maintenance procedure steps 1 through 3, and pull the stem (key 14) out of the guide insert (key 18).
5. Install the stem (key 14) into the guide insert (key 18) and perform Body Area Maintenance procedure steps 7 through 10 as necessary.
6. Install the lever assembly (key 16) into the stem (key 14) and secure the lever assembly (key 16) with the machine screws (key 17).
7. Reassemble the diaphragm parts as follows:
  - Pusher post (key 8)
  - Diaphragm head gasket (key 45)
  - Diaphragm head (key 7)
  - Diaphragm (key 10)

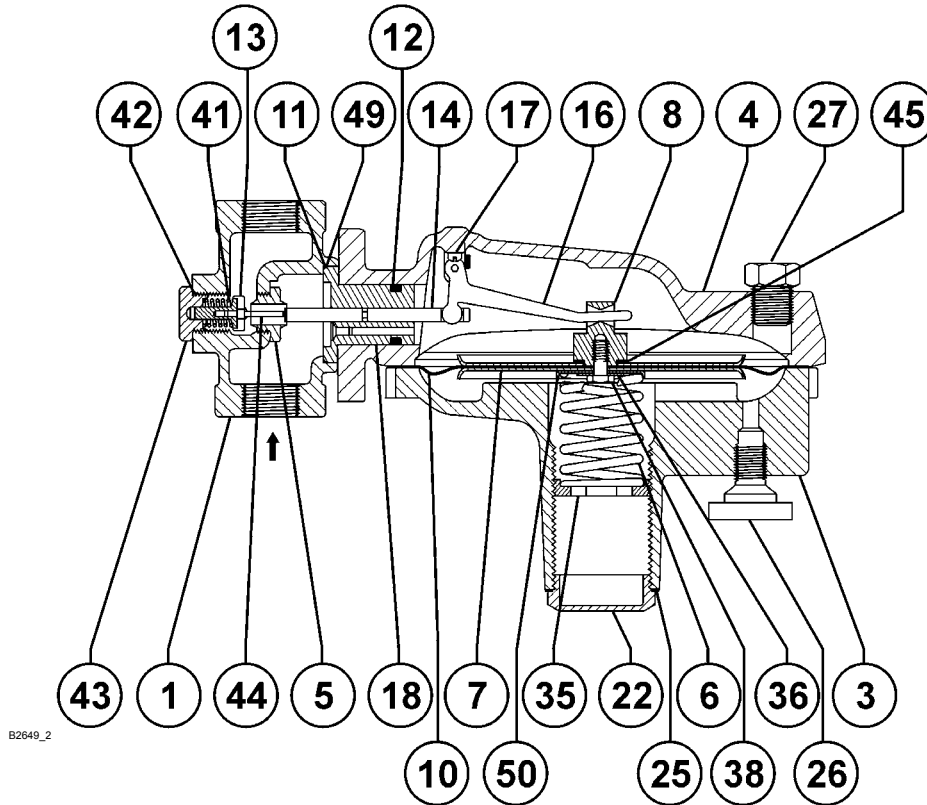

Figure 3. Type Y695A Assembly

Diaphragm head (key 7)

Lower spring seat (key 50)

Washer (key 36)

Diaphragm plate cap screws (key 38)

Secure using 5 to 6 foot-pounds (7 to 8 N•m) of torque.

8. Install the pusher post (key 8) plus attached diaphragm parts onto the lever assembly (key 16).
9. Install the spring case (key 3) on the diaphragm casing (key 4) so that the vent assembly (key 26) is correctly oriented, and secure it with the cap screws (key 24) and hex nuts (key 23, not shown) fingertight.
10. Install the control spring (key 6) and the adjusting screw (key 35) in the spring case (key 3). Turn the adjusting screw (key 35) clockwise until there is enough control spring (key 6) force to provide proper slack to the diaphragm (key 10). Using a crisscross pattern, finish tightening the cap screws (key 24) and hex nuts (key 23, not shown) to 160 to 190 inch-pounds (22 to 26 N•m) of torque. To adjust the outlet pressure to the desired setting, refer to the Startup and Adjustment section.
11. Install a replacement closing cap gasket (key 25) if necessary, and then install the closing cap (key 22).

## To Convert Constructions

### The Type Y695A to the Type Y695AM:

New parts required: keys 30, 31, and 33

1. Remove pipe plug (key 27) from the diaphragm casing (key 4).
2. Refer to steps 1 through 3 in the Body Area Maintenance section.
3. Insert the throat seal O-ring (key 31, Figure 5) and machine screw (key 33, Figure 5).
4. Insert the stem seal O-ring (key 30) by following steps 1 through 6 and 8 through 11 in the Diaphragm and Spring Case Area Maintenance section.
5. Reassemble following steps 7 through 10 of the Body Area Maintenance section.

### The Type Y695AM to the Type Y695A:

New parts required: key 27

1. Insert pipe plug (key 27) in the diaphragm casing (key 4).
2. Follow steps 1 through 6 and 8 through 11 in the Diaphragm and Spring Case Area Maintenance section to remove the stem seal O-ring (key 30, Figure 5).

# Y695A Series

**Table 2. Body Materials and Part Numbers (Body, key 1)**

BODY MATERIAL	END CONNECTION STYLE <sup>(1)</sup>	PART NUMBER	
		NPS 3/4 (DN 20) Body	NPS 1 (DN 25) Body
Ductile iron	NPT	17B9020X012	17B9020X022
CF8M Stainless steel	NPT	17B9020X032	17B9020X042
	ASME CL150 RF	17B5280X012	17B5280X022
	ASME CL300 RF	17B5280X032	17B5280X042
	PN 16/25/40	17B5280X052	17B5280X062
CF8M Stainless steel with Carbon steel flanges	ASME CL150 RF	17B5280X072	17B5280X082
	ASME CL300 RF	17B5280X092	17B5280X102
	PN 16/25/40	17B5280X112	17B5280X122
Hastelloy® C	ASME CL150 RF	----	17B9731X012

1. All flanges are welded on except Hastelloy® C. All flange dimensions are 14-inches (356 mm) face-to-face.

- Follow steps 1 through 5 of Body Area Maintenance to remove the throat seal (key 31, Figure 5) and machine screw (key 33, Figure 5).
- Reassemble following steps 7 through 10 of the Body Area Maintenance section.

Key	Description	Part Number
8	Pusher Post 316 Stainless steel Hastelloy® C	18B3465X012 18B3465X022
10*	Diaphragm Nitrile (NBR) Fluorocarbon (FKM) Nitrile (NBR) with Polytetrafluoroethylene (PTFE)	37B9720X012 23B0101X052 34B4375X012
11*	Body Seal O-Ring Nitrile (NBR) Fluorocarbon (FKM) Perfluoroelastomer (FFKM) Ethylene propylene (EPDM)	1H993806992 1H9938X0012 1H9938X0042 1H9938X0022
12*	Insert Seal Nitrile (NBR) Fluorocarbon (FKM) Perfluoroelastomer (FFKM) Ethylene propylene (EPDM)	1B885506992 1B8855X0012 1B8855X0062 1B8855X0022
13*	Disk Assembly 316 Stainless Steel with Nitrile (NBR) Fluorocarbon (FKM) Perfluoroelastomer (FFKM) Ethylene propylene (EPDM) Hastelloy® C with PTFE	1E9848X0042 1E9848X0032 1E9848X0052 1E9848X0062 1E9848X0072
14	Stem 316 Stainless steel Hastelloy® C	17B5278X012 17B5278X022
16	Lever Assembly Stainless steel Hastelloy® C	1B5375000B2 1B5375X0092
17	Machine Screw (2 required) Stainless steel Hastelloy® C	19A7151X022 17B9736X012
18	Guide Insert Stainless steel Hastelloy® C	27B4028X022 27B4028X032
22	Closing Cap Plastic ( <b>standard</b> ) Steel Stainless steel	T13524T0062 1E422724092 1E422735072
23	Hex Nut (8 required) (not shown) Ductile iron Stainless steel	1A352724122 1E9440X0352
24	Cap Screw (8 required) Ductile iron Stainless steel	1A352524052 18B3455X012
25*	Closing Cap Gasket (Steel and Stainless steel Closing Cap only)	1P753306992
26	Vent Assembly Spring Case Down, Type Y602-1	17A6570X012

## Parts Ordering

When contacting your local Sales Office about this regulator, include the type number and all other pertinent information stamped on the nameplate. Specify the complete 11-character part number from the following parts list when ordering replacement parts.

## Parts List

Key	Description	Part Number
	Spare Parts, included are keys 10, 11, 12, 25, 30, 31, 33, 42, and 45 (Stainless steel/Nitrile (NBR) Construction) Kit [Kit does not include disk (key 13)] Disk (key 13)	RY690AX0012 1E9848X0042
1	Body	See Table 2
2	Cap Screw (2 required) Ductile iron Stainless steel	1C856228992 18B3456X012
3	Spring Case Assembly Ductile iron CF8M Stainless steel	13B0109X042 13B0109X032
4	Diaphragm Casing Ductile iron CF8M Stainless steel Hastelloy® C	47B3063X012 47B3064X012 47B3064X022
5	Orifice, 7/16-inch (11 mm) 316 Stainless steel Hastelloy® C	0L0832X0012 0L0832X0022
6	Spring 2 to 7-inches w.c. (5 to 17 mbar) 3 to 13-inches w.c. (7 to 32 mbar) 10 to 26-inches w.c. (25 to 65 mbar) 0.9 to 2.5 psig (0,06 to 0,17 bar) 1.3 to 4.5 psig (0,09 to 0,31 bar) 3.8 to 7 psig (0,26 to 0,48 bar)	1B653827052 1B653927022 1B537027052 1B537127022 1B537227022 1B537327052
7	Diaphragm Head (2 required) S304 Stainless steel Hastelloy® C	17B9723X032 17B9723X022

\*Recommended spare part.

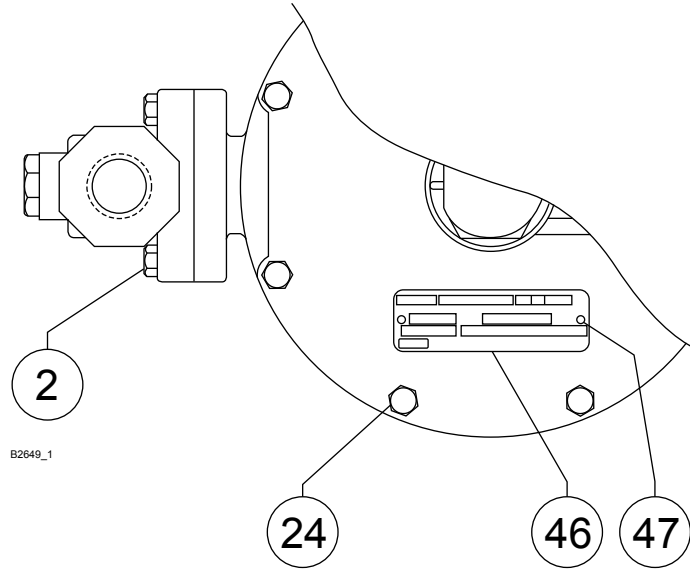

Figure 4. Types Y695A and Y695AM Assembly Detail

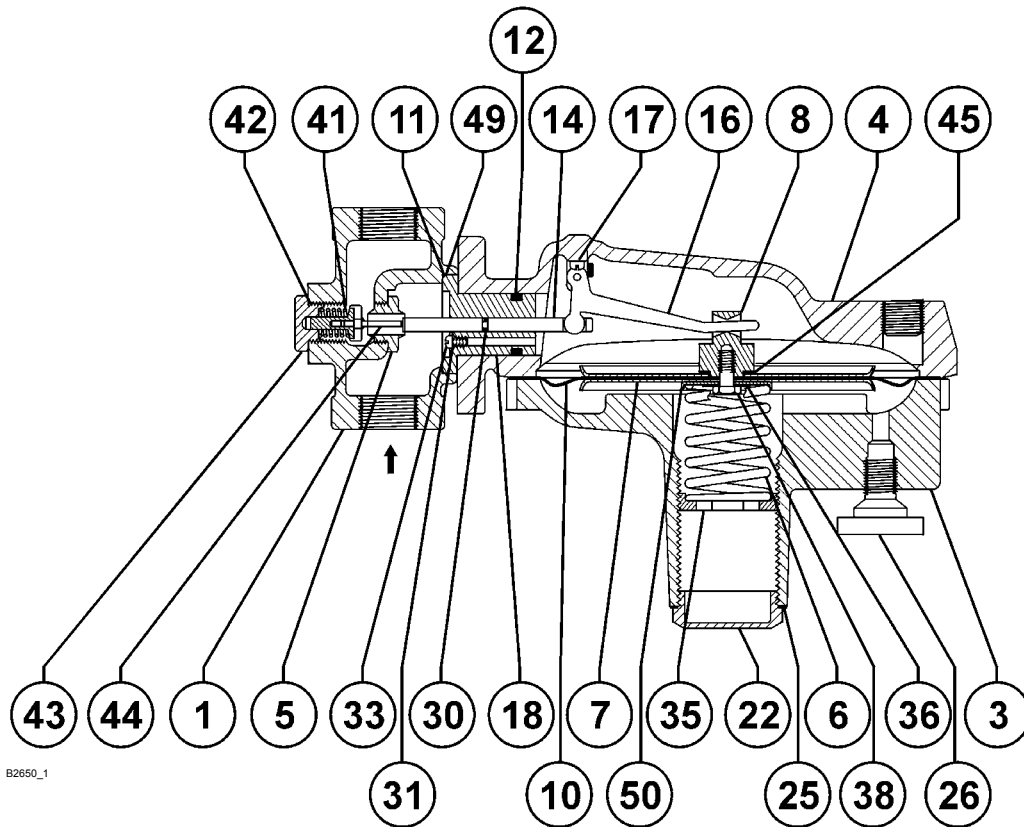

Figure 5. Type Y695AM Assembly

# Y695A Series

Key	Description	Part Number	Key	Description	Part Number
27	Pipe Plug		38	Cap Screw	1B290524052
	Steel	1A369224492	41	Back Disk Spring	
	Stainless steel	1A369235072		Stainless steel	1E984637022
	Hastelloy® C	1A369240012		Hastelloy® C and NACE	18B0255X012
30*	Stem Seal (Type Y695AM only)		42*	Back Body Seal	
	Nitrile (NBR)	1H2926G0012		Nitrile (NBR)	13A1584X012
	Fluorocarbon (FKM)	1H2926X0022		Fluorocarbon (FKM)	13A1584X022
	Perfluoroelastomer (FFKM)	1H2926X0042		Perfluoroelastomer (FFKM)	13A1584X032
	Ethylene propylene (EPDM)	1H2926X0012		Ethylene propylene (EPDM)	13A1584X042
31*	Throat Seal (Type Y695AM only)		43	Back Body Cap	
	Nitrile (NBR)	1D682506992		Stainless steel	1F2737X0012
	Fluorocarbon (FKM)	1D6825X0012		Hastelloy® C	1F2737X0022
	Perfluoroelastomer (FFKM)	1D6825X0032	44	Disk Spacer	
	Ethylene propylene (EPDM)	1D6825X0042		Stainless steel	1E9861X0012
33	Machine Screw (Type Y695AM only)			Hastelloy® C	1E9861X0022
	Stainless steel	18A0703X022	45*	Diaphragm Head Gasket	18B3450X012
	Hastelloy® C	18A0703X032	47	Drive Screw (2 required)	1A368228982
35	Adjusting Screw	1B537944012	49	Backup Ring	18B3446X012
36	Washer	18B3440X012	50	Lower Spring Seat	1B636325062

\*Recommended spare part.

## Industrial Regulators

### Emerson Process Management Regulator Technologies, Inc.

USA - Headquarters  
McKinney, Texas 75069-1872 USA  
Tel: 1-800-558-5853  
Outside U.S. 1-972-548-3574

Asia-Pacific  
Shanghai, China 201206  
Tel: +86 21 2892 9000

Europe  
Bologna, Italy 40013  
Tel: +39 051 4190611

Middle East and Africa  
Dubai, United Arab Emirates  
Tel: +971 4811 8100

## Natural Gas Technologies

### Emerson Process Management Regulator Technologies, Inc.

USA - Headquarters  
McKinney, Texas 75069-1872 USA  
Tel: 1-800-558-5853  
Outside U.S. 1-972-548-3574

Asia-Pacific  
Singapore, Singapore 128461  
Tel: +65 6777 8211

Europe  
Bologna, Italy 40013  
Tel: +39 051 4190611  
Gallardon, France 28320  
Tel: +33 (0)2 37 33 47 00

## TESCOM

### Emerson Process Management Tescom Corporation

USA - Headquarters  
Elk River, Minnesota 55330-2445 USA  
Tel: 1-763-241-3238

Europe  
Selmsdorf, Germany 23923  
Tel: +49 (0) 38823 31 0

For further information visit [www.fisherregulators.com](http://www.fisherregulators.com)

The Emerson logo is a trademark and service mark of Emerson Electric Co. All other marks are the property of their prospective owners. Fisher is a mark owned by Fisher Controls, Inc., a business of Emerson Process Management.

The contents of this publication are presented for informational purposes only, and while every effort has been made to ensure their accuracy, they are not to be construed as warranties or guarantees, express or implied, regarding the products or services described herein or their use or applicability. We reserve the right to modify or improve the designs or specifications of such products at any time without notice.

Emerson Process Management does not assume responsibility for the selection, use or maintenance of any product. Responsibility for proper selection, use and maintenance of any Emerson Process Management product remains solely with the purchaser.