

Fisher® Lever-Lock Handlever Actuators for POSI-SEAL™ A81 Rotary Valves

Contents

Introduction	1
Scope of Manual	1
Description	1
Specifications	2
Installation	3
Ordering Replacements	5

Introduction

Scope of Manual

This instruction manual includes installation, maintenance, and parts information for the Fisher Lever-Lock handlever actuator (figure 1). Refer to separate instruction manuals for information covering the control valves.

Do not install, operate, or maintain a Lever-Lock actuator without being fully trained and qualified in valve, actuator, and accessory installation, operation, and maintenance. To avoid personal injury or property damage, it is important to carefully read, understand, and follow all the contents of this manual, including all safety cautions and warnings. If you have any questions about these instructions, contact your Emerson Process Management sales office before proceeding.

Description

The Lever-Lock handlever is used for reliable manual operation of DN 50 through 150 (NPS 2 through 6) Fisher A81 high-performance butterfly valves. Spring-loading secures the handlever in the notched quadrant plate (figure 2), allowing the valve disk to be locked in intermediate positions. Additionally, the handlever can be locked with a user-supplied padlock with 4.8 to 5.2 mm (3/16 to 13/64 inch) shackle to prevent accidental or unauthorized adjustment (see figures 3 and 4).



Figure 1. Fisher Lever-Lock Handlever Actuator Mounted on Valve



Lever-Lock Handlever Actuator

May 2009

Table 1. Specifications

<p>Lever-Lock Handlever Actuator Sizes</p> <p>See table 2</p> <p>Valve Compatibility</p> <p>Mounts on A81 valves per table 2</p> <p>Maximum torque Output</p> <p>See table 3</p>	<p>Handlever Length</p> <p>Maximum of 432 mm (17 inches). See figure 2 and table 4</p> <p>Construction Materials</p> <p>Handle, quadrant plate, lever, and mounting bracket are all steel materials. Spring, set screws, and fasteners are stainless steel</p> <p>Dimension and Approximate Weights</p> <p>See figure 2 and table 4</p>
-------------------------------------------------------------------------------------------------------------------------------------------------------------------------------------------------------	--------------------------------------------------------------------------------------------------------------------------------------------------------------------------------------------------------------------------------------------------------------------------------------------------------------------------------------------------------------

1. The pressure/temperature limits in this manual, and any applicable code or standard limitation, should not be exceeded.

Table 2. Fisher A81 Valve / Lever-Lock Handlever Compatibility

HANDLEVER ACTUATOR SIZE	VALVE SIZE		SHAFT SIZE		SQUARE SIZE
	DN	NPS	mm	Inches	mm
I	50	2	12.7	1/2	9
	80	3	15.9	5/8	11
II	100	4	19.1	3/4	14
	150	6	25.4	1	17

Table 3. Maximum Allowable Torques and Handlever Force Requirements

VALVE DISK POSITION	MAXIMUM TORQUE				HANDLEVER FORCE REQUIRED	
	Size I		Size II		N	Lbf
	N•m	In•Lb	N•m	In•Lb		
0 Degrees (Breakout Torque)	119	1050	164	1450	423	95
All Other Angles (Dynamic Torque)	47	420	70	620	178	40

Installation

The Lever-Lock handlever actuator is normally shipped mounted on the valve at the factory. If the handlever was ordered separately, install the handlever on the valve by following the instructions in this section.



WARNING

Sudden or unexpected movement of the handle can result from unbalanced flow forces. Firmly grip the handlever and ensure stable footing when operating the handlever to avoid personal injury or property damage.

Installing the Handlever

Orientation

Mount the Lever-Lock bracket assembly, less the handle, to the valve body. The handle is perpendicular to the pipeline when the valve is in the shut position. Rotation of the lever/valve shaft in the counter-clockwise direction will open the valve. Attach the Lever-Lock Handlever actuator to the valve in this orientation but do not fully tighten

(torque) the bracket to valve bolting until after the zeroing process below.

Handle assembly

Place the handle and lever assembly on the valve shaft with the valve closed. Squeeze the lever to compress the spring, position the lever over the notch indicating the closed position, and slide the square cutout portion of the handle over the valve shaft as far as it will go. Maintain at least a 0.8 mm (1/32 inch) gap between the handle and the plate, so the handle doesn't rub on the plate during operation. Torque the two hex socket set screws against the shaft to 2.7 N•m (24 in•lbf).

Zeroing

After tightening the set screws, check the orientation of the disk relative to the body seal retainer. Place a straight edge on the seal retainer which spans the valve opening. Visually check to ensure there is equal space (within 0.8 mm [1/32 inch]) between this straight edge and the top and bottom of the disk to ensure the valve is fully engaged in the seal. To adjust this position, rotate the bracket within the clearance of the mounting bolt holes between the valve body and bracket. Once there is equal distance between the disk and the straight edge, tighten the mounting bolts to 115 N•m (88 ft•lbf). After tightening, recheck disk position at shutoff to ensure nothing shifted during the tightening process.

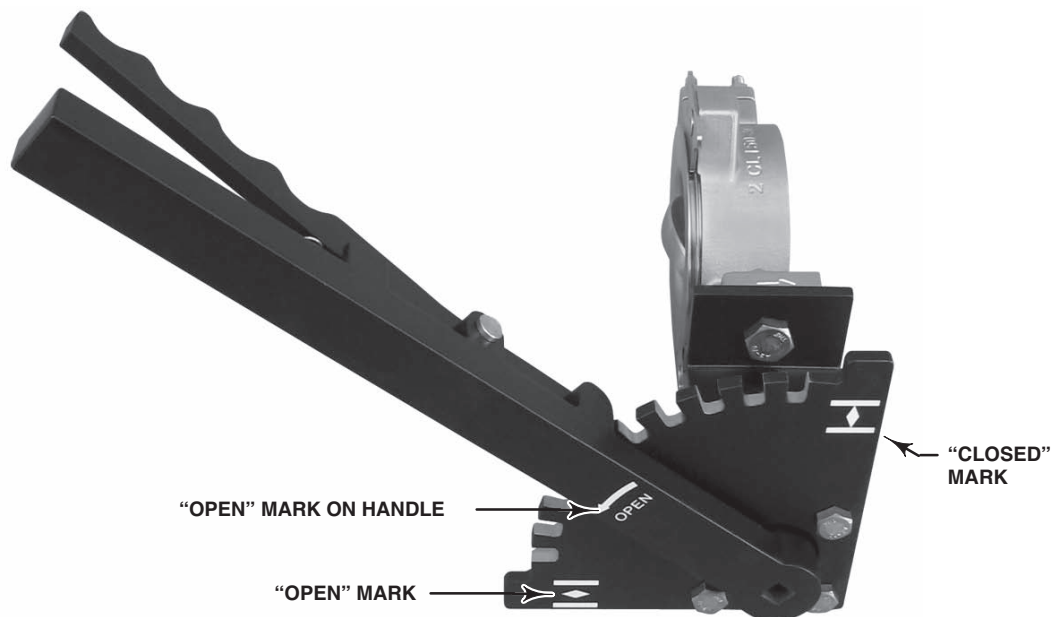

W9583

Figure 2. Fisher Lever-Lock Handlever Actuator for A81 Valve (Open/Closed Marks)

Lever-Lock Handlever Actuator

Maintenance

Handlever parts are subject to normal wear/corrosion and must be inspected and replaced when necessary. The frequency of inspection and replacement depends on the severity of service conditions.

WARNING

Avoid personal injury or damage to property from sudden release of pressure or uncontrolled process fluid. Before starting disassembly:

- Do not remove the actuator from the valve while the valve is still pressurized.
- Always wear protective gloves, clothing, and eyewear when performing any maintenance operations to avoid personal injury.

- Use bypass valves or completely shut off the process to isolate the valve from process pressure. Relieve process pressure on both sides of the valve. Drain the process media from either side of the valve.

- Use lock-out procedures to be sure that the above measures stay in effect while you work on the equipment.

- The valve packing box may contain process fluids that are pressurized, *even when the valve has been removed from the pipeline.* Process fluids may spray out under pressure when removing the packing hardware or packing rings, or when loosening the packing box pipe plug.

- Check with your process or safety engineer for any additional measures that must be taken to protect against process media.

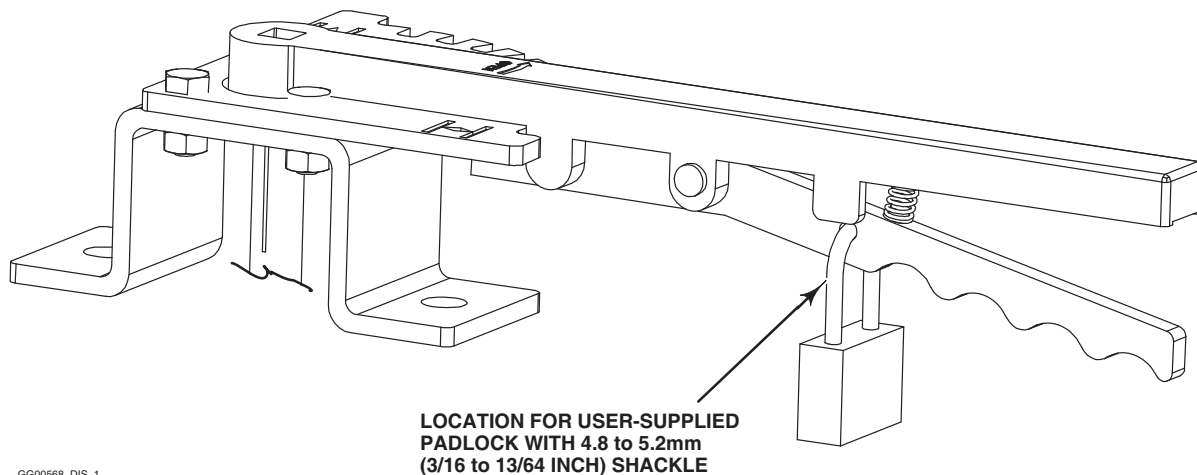

GG00568_DIS_1

Figure 3. Fisher Lever-Lock Handlever Actuator for A81 Valve (Showing Padlock Location)

Ordering Replacements

When corresponding with your Emerson Process Management sales office about this equipment, always mention the valve serial number. It is recommended that complete assemblies are considered for replacements to ensure the latest version of the product is supplied.



WARNING

Use only genuine Fisher replacement parts. Components that are not supplied by Emerson Process Management should not, under any

circumstances, be used in any Fisher valve, because they may void your warranty, might adversely affect the performance of the valve, and could cause personal injury and property damage.

Note

Neither Emerson, Emerson Process Management, nor any of their affiliated entities assumes responsibility for the selection, use, or maintenance of any product. Responsibility for the selection, use, and maintenance of any product remains with the purchaser and end user.

Lever-Lock Handlever Actuator

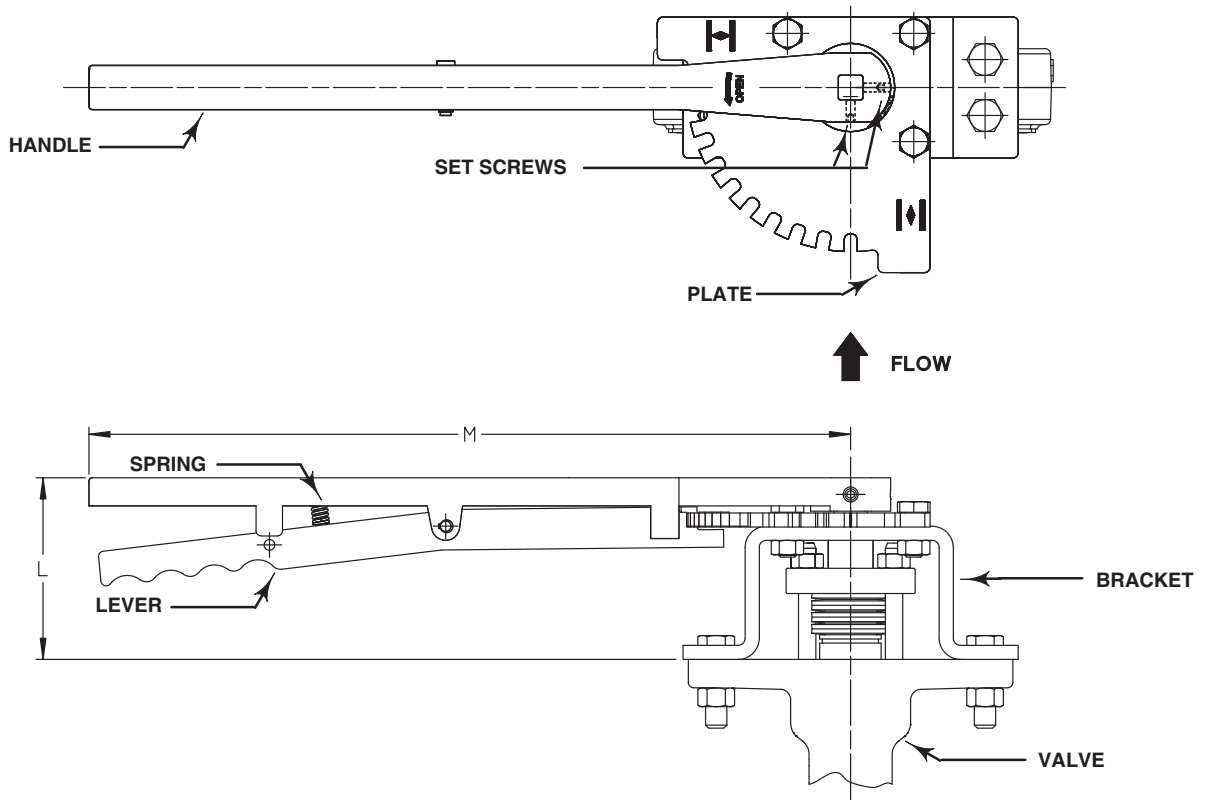

GG03237_1

Figure 4. Fisher Lever-Lock Handlever Actuator for A81 Valve (fully closed valve position shown)

Table 4. Dimensions and Weights

VALVE SIZE		M		L		WEIGHT	
DN	NPS	mm	Inch	mm	Inch	kg	lbs
50	2	315	12.4	85	3.35	2.72	3
80	3	315	12.4	85	3.35	2.72	3
100	4	432	17.0	103	4.06	3.63	4
150	6	432	17.0	103	4.06	3.63	4

Fisher and POSI-SEAL are marks owned by one of the companies in the Emerson Process Management business division of Emerson Electric Co. Emerson Process Management, Emerson, and the Emerson logo are trademarks and service marks of Emerson Electric Co. All other marks are the property of their respective owners.

The contents of this publication are presented for informational purposes only, and while every effort has been made to ensure their accuracy, they are not to be construed as warranties or guarantees, express or implied, regarding the products or services described herein or their use or applicability. All sales are governed by our terms and conditions, which are available upon request. We reserve the right to modify or improve the designs or specifications of such products at any time without notice. Neither Emerson, Emerson Process Management, nor any of their affiliated entities assumes responsibility for the selection, use or maintenance of any product. Responsibility for proper selection, use, and maintenance of any product remains solely with the purchaser and end-user.

Emerson Process Management

Marshalltown, Iowa 50158 USA

Sorocaba, 18087 Brazil

Chatham, Kent ME4 4QZ UK

Dubai, United Arab Emirates

Singapore 128461 Singapore

www.Fisher.com