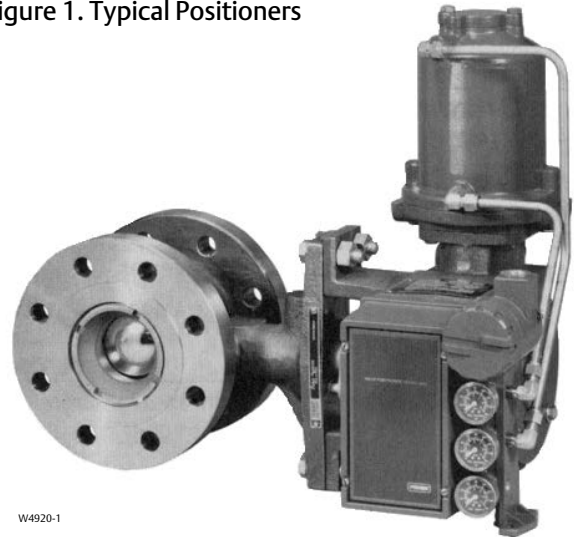


# Fisher™ 3610J and 3620J Positioners and 3622 Electro-Pneumatic Converter

## Contents

Introduction .....	2
Scope of Manual .....	2
Description .....	2
Type Number Description .....	6
Specifications .....	6
Educational Services .....	7
Installation .....	7
Hazardous Area Classifications and Special Instructions for “Safe Use” and Installation in Hazardous Locations for 3622 converter .....	8
Mounting 3610J and 3620J Positioners on 2052 Actuators .....	8
Changing Cams—Actuator Styles A, B, C, and D .....	10
Mounting 3611JP and 3621JP Positioners on 585 and 585R Actuators .....	10
Mounting 3611JP and 3621JP Positioners on 585C and 585CR Actuators .....	12
Mounting 3611JP and 3621JP Positioners on Long Travel Sliding-Stem Actuators .....	14
Installing the 3622 Electro-Pneumatic Converter .....	15
Changing Positioner Types .....	15
Pressure Connections .....	16
Supply Connection .....	16
Output Connections .....	17
Instrument Connection .....	18
Diagnostic Connections .....	19
Vent Connection .....	19
Electrical Connections for 3620J Positioners .....	20
Calibration .....	21
Minor Loop Gain Adjustment .....	21
Crossover Adjustment .....	23
3610J or 3620J Positioner, Spring and Diaphragm Actuators .....	23
3610JP, 3611JP, 3620JP, or 3621JP Positioner, Piston Actuators .....	23

Figure 1. Typical Positioners



W4920-1

**3620JP POSITIONER WITH  
1061 ACTUATOR AND V500 VALVE**



X1284

**3610J POSITIONER WITH  
2052 ACTUATOR AND V500 VALVE**

Zero and Span Adjustments .....	24	Disassembling the Nozzle Assembly .....	38
Changing Positioner Action .....	26	Disassembling the Input Module .....	39
Changing to Direct Action .....	26	Positioner Reassembly .....	39
Changing to Reverse Action .....	27	Assembling the Input Module .....	39
Split Range Operation .....	27	Assembling the Nozzle Assembly .....	40
Characterized Cams for 3610J, 3610JP, 3620J, and 3620JP Positioners .....	28	Assembling the Summing Beam Assembly ..	40
Principle of Operation .....	29	Assembling the Relay .....	41
Maintenance .....	32	Assembling the Reversing Plate and Gasket .....	42
Positioner Disassembly .....	34	Assembling the Gauge Block .....	42
Removing the Positioner from the Actuator .	34	Assembling the 3622 Electro-Pneumatic Converter .....	42
Disassembling the Bypass Valve .....	35	Assembling the Feedback Lever Assembly ...	43
Disassembling the Gauge Block .....	35	Assembling the Bypass Valve Assembly .....	43
Disassembling the 3622 Electro-Pneumatic Converter .....	36	Changing Positioner Types .....	44
Disassembling the Feedback Lever Assembly .....	36	Parts Ordering .....	46
Disassembling the Reversing Plate and Gasket .....	37	Parts Kits .....	46
Disassembling the Relay .....	37	Parts List .....	46
Disassembling the Summing Beam Assembly .....	37	Positioner Common Parts .....	46
		3622 Electro-Pneumatic Converter .....	49
		Diagnostic Connections .....	50

## Introduction

### Scope of Manual

This instruction manual includes installation, operation, calibration, maintenance, and parts ordering information for Fisher 3610J and 3620J positioners. (i.e. 3610J, 3610JP, 3611JP, 3620J, 3620JP, and 3621JP). This manual also provides field installation information for the Fisher 3622 electro-pneumatic converter. Refer to separate instruction manuals for information on the actuator and control valve. Contact your [Emerson sales office](#) if assistance is needed in obtaining actuator or control valve instruction manuals.



Do not install, operate or maintain a 3610J or 3620J positioner without being fully trained and qualified in valve, actuator and accessory installation, operation and maintenance. To avoid personal injury or property damage it is important to carefully read, understand, and follow all of the contents of this manual, including all safety cautions and warnings. If you have any questions about these instructions, contact your Emerson sales office before proceeding.

### Description

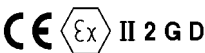
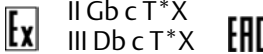
3610J or 3610JP pneumatic positioners and 3620J or 3620JP electro-pneumatic positioners are used with diaphragm rotary actuators and piston rotary actuators as shown in figure 1. 3611JP and 3621JP positioners are used with Fisher 585, 585R, 585C, 585CR, or other sliding-stem actuators, as shown in figure 2.

Table 1. Specifications

<p>Unless otherwise specified, the specifications listed are for all positioner type numbers</p> <p><b>Available Configurations</b> Refer to the type number description on page 6</p> <p><b>Input Signal</b> 3610J, 3610JP, and 3611JP: Standard: ■ 0.2 to 1.0 bar (3 to 15 psig), ■ 0.4 to 2.0 bar (6 to 30 psig), or ■ split range, see table 8 <i>Adjustable:</i> Zero is adjustable from 0.07 to 1.5 bar (1 to 22 psig) for standard valve rotations or valve travels. Span is adjustable from 0.2 to 2.0 bar (3.2 to 28.8 psi) for standard valve rotations or valve travels. Adjustment locations are shown in figure 14. 3620J, 3620JP, and 3621JP: 4 to 20 mA DC constant current with 30 VDC maximum compliance voltage. Minimum terminal voltage is 2.4 VDC at 20 mA. Split range is also available, see table 8.</p> <p><b>Equivalent Circuit</b> 3620J, 3620JP, and 3621JP: 120 ohms shunted by three 5.6 V zener diodes</p> <p><b>Output Signal</b> Pneumatic pressure as required by the actuator up to full supply pressure Action<sup>(1)</sup>: Field-reversible between ■ direct and ■ reverse within the pneumatic positioner</p> <p><b>Typical Performance for 3610J, 3610JP, 3620J, and 3620JP Positioners with 1051, 1052, and 1061 Actuators</b></p> <p><b>Independent Linearity</b> <i>Direct-Acting 3610J and 3620J:</i> ±1.5% of output span <i>Reverse-Acting 3610J and 3620J:</i> ±0.75% of output span <i>Direct-Acting 3610JP and 3620JP:</i> ±1.25% of output span <i>Reverse-Acting 3610JP and 3620JP:</i> ±0.5% of output span</p> <p><b>Hysteresis</b> 3610J: 1.0% of output span 3620J: 0.75% of output span 3610JP: 0.5% of output span 3620JP: 0.6% of output span</p> <p><b>Deadband:</b> 0.1% of input span Refer to table 3 for typical performance for 3611JP and 3621JP positioners</p>	<p><b>Electromagnetic Compatibility for 3622 electro-pneumatic converter</b> Meets EN 61326-1:2013 Immunity—Industrial locations per Table 2 of the EN 61326-1 standard. Performance is shown in table 2 below. Emissions—Class A ISM equipment rating: Group 1, Class A</p> <p>The electromagnetic compatibility specifications also apply to 3620J, 3620JP, and 3621JP electro-pneumatic positioners.</p> <p><b>Maximum Supply Air Demand<sup>(2)</sup></b></p> <p>3610J and 3620J: 1.4 bar (20 Psig) Supply: 13 normal m<sup>3</sup>/hour (490 scfh) 2.4 bar (35 Psig) Supply: 17 normal m<sup>3</sup>/hour (640 scfh) 3610JP, 3620JP, 3611JP, and 3621JP: 5.2 Bar (75 Psig) Supply: 37 normal m<sup>3</sup>/hour (1380 scfh) 6.9 Bar (100 Psig) Supply: 46 normal m<sup>3</sup>/hour (1700 scfh)</p> <p><b>Operating Influences for 3610J, 3610JP, 3620J, and 3620JP</b></p> <p>Supply Pressure Sensitivity: A 10% change in supply pressure changes the valve shaft position less than the following percentages of valve rotation: 3610J and 3620J: 1.0% at 1.4 bar (20 psig) supply pressure 3610JP and 3620JP: 1.5% at 4.1 bar (60 psig) supply pressure</p> <p><b>Supply Pressure<sup>(3)</sup></b></p> <p><b>Minimum Recommended:</b> 0.3 bar (5 psig) above actuator requirement [1.4 bar (20 psig) for a 0.2 to 1.0 bar (3 to 15 psig) nominal actuator signal; 2.4 bar (35 psig) for a 0.4 to 2.0 bar (6 to 30 psig) nominal actuator signal] <b>Maximum:</b> 10.3 bar (150 psig) or maximum pressure rating of the actuator, whichever is lower</p>
--	---

- continued -

Table 1. Specifications (Continued)

<p><b>Supply Medium: Air or Natural Gas</b></p> <p>Supply medium must be clean, dry, and noncorrosive</p> <p><b>Per ISA Standard 7.0.01</b> A maximum 40 micrometer particle size in the air system is acceptable. Further filtration down to 5 micrometer particle size is recommended. Lubricant content is not to exceed 1 ppm weight (w/w) or volume (v/v) basis. Condensation in the air supply should be minimized</p> <p><b>Per ISO 8573-1</b> <i>Maximum particle density size: Class 7</i> <i>Oil content: Class 3</i> <i>Pressure Dew Point: Class 3 or at least 10°C less than the lowest ambient temperature expected</i></p> <p>3620J, 3620JP, 3621JP positioners are not approved for use with natural gas as the supply medium.</p> <p><b>Steady-State Air Consumption<sup>(2)</sup></b></p> <p>3610J: 0.40 normal m<sup>3</sup>/hour (15 scfh) at 1.4 bar (20 psig) supply pressure 3610JP: 0.64 normal m<sup>3</sup>/hour (24 scfh) at 6.9 bar (100 psig) supply pressure 3620J: 0.49 normal m<sup>3</sup>/hour (18.2 scfh) at 1.4 bar (20 psig) supply pressure 3620JP: 0.93 normal m<sup>3</sup>/hour (35.0 scfh) at 6.9 bar (100 psig) supply pressure</p> <p><b>Operative Temperature Limits<sup>(3)</sup></b></p> <p>-40 to 82°C (-40 to 180°F)</p> <p><b>Hazardous Area Classification for 3610J, 3610JP, and 3611JP</b></p> <p>Complies with the requirements of ATEX Group II Category 2 Gas and Dust</p> <p> Ex h IIC Tx Gb Ex h IIIC Tx Db</p> <p>Maximum surface temperature (Tx) depends on operating conditions</p> <p>Gas: T6 Dust: T82</p> <p>Meets Customs Union technical regulation TP TC 012/2011 for Groups II/III Category 2 equipment</p> <p></p>	<p><b>Electrical Classification for 3622</b></p> <p><b>Hazardous Area:</b></p> <p>CSA—Intrinsically Safe, Explosion proof, Type n, Dust-Ignition proof, DIV 2</p> <p>FM—Intrinsically Safe, Explosion proof, Type n, Dust-Ignition proof, Non-incendive</p> <p>ATEX—Intrinsically Safe, Flameproof, Type n</p> <p>IECEX—Intrinsically Safe, Flameproof, Type n (Gas Atmospheres only)</p> <p><b>Note:</b> These classifications also apply to 3620J positioners</p> <p><b>Other Classifications/Certifications for 3622</b></p> <p>CUTR—Customs Union Technical Regulations (Russia, Kazakhstan, Belarus, and Armenia)</p> <p>INMETRO— National Institute of Metrology, Quality and Technology (Brazil)</p> <p>KTL— Korea Testing Laboratory (South Korea)</p> <p>Contact your <a href="#">Emerson sales office</a> for classification/certification specific information</p> <p><b>Note:</b> These classifications also apply to 3620J positioners</p> <p><b>Housing Classification for 3622</b></p> <p>CSA—Type 3 Encl.</p> <p>FM—NEMA 3, IP54</p> <p>ATEX—IP64</p> <p>IECEX—IP54</p> <p>Mount instrument with vent on side or bottom if weatherproofing is a concern</p> <p><b>Note:</b> These classifications also apply to 3620J positioners</p> <p><b>Pressure Connections</b></p> <p>1/4 NPT internal</p> <p><b>Electrical Connection for 3620J, 3620JP, and 3621JP</b></p> <p>1/2-14 NPT conduit connection</p>
--	---

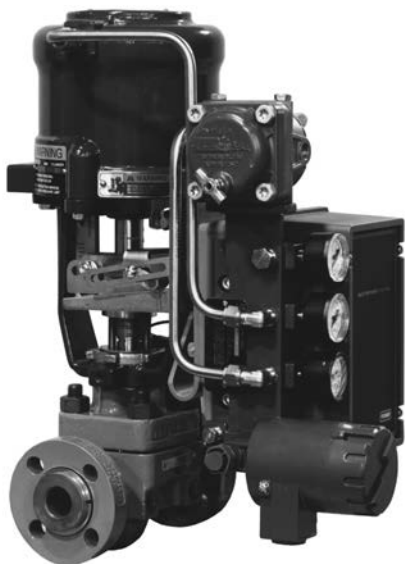
- continued -

Table 1. Specifications (Continued)

<p><b>Rotary Valve Rotation</b> 60, 75, or 90 degrees</p> <p><b>Sliding-Stem Valve Travel</b> 102 mm (4 inches), adjustable to lesser travel with standard input signals Contact your Emerson sales office for travel greater than 102 mm (4 inches)</p> <p><b>Approximate Weight</b> 3610J positioners: 2.5 kg (5.6 pounds) 3620J positioners: 3.6 kg (8.0 pounds)</p>	<p><b>Declaration of SEP</b></p> <p>Fisher Controls International LLC declares this product to be in compliance with Article 4 paragraph 3 of the PED Directive 2014/68/EU. It was designed and manufactured in accordance with Sound Engineering Practice (SEP) and cannot bear the CE marking related to PED compliance.</p> <p>However, the product <i>may</i> bear the CE marking to indicate compliance with <i>other</i> applicable European Community Directives.</p>
---	--

NOTE: Specialized instrument terms are defined in ANSI/ISA Standard 51.1 - Process Instrument Terminology.  
 1. For direct action, an increasing input signal extends actuator rod. For reverse action, an increasing input signal retracts actuator rod.  
 2. Normal m<sup>3</sup>/hr—Normal cubic meters per hour (0°C and 1.01325 bar, absolute). Scfh—Standard cubic feet per hour (60°F and 14.7 psia).  
 3. The pressure and temperature limits in this document, and any applicable code or standard should not be exceeded.

Figure 2. Fisher 3621JP Positioner with 585C Actuator



W6594

Table 2. Fisher 3622 Electro-Pneumatic Converter<sup>(1)</sup> EMC Summary Results—Immunity

Port	Phenomenon	Basic Standard	Test Level	Performance Criteria <sup>(1)</sup>
Enclosure	Electrostatic Discharge (ESD)	IEC 61000-4-2	4 kV contact; 8 kV air	A
	Radiated EM field	IEC 61000-4-3	80 to 1000 MHz @ 10V/m with 1 kHz AM at 80% 1400 to 2000 MHz @ 3V/m with 1 kHz AM at 80% 2000 to 2700 MHz @ 1V/m with 1 kHz AM at 80%	A
	Rated power frequency magnetic field	IEC 61000-4-8	60 A/m at 50 Hz	A
I/O signal/control	Burst	IEC 61000-4-4	1 kV	A
	Surge	IEC 61000-4-5	1 kV (line to ground only, each)	B
	Conducted RF	IEC 61000-4-6	150 kHz to 80 MHz at 3 Vrms	A

Specification limit = ±1% of span  
 1. The information contained in the table also applies to 3620J, 3620JP, and 3621JP electro-pneumatic positioners.  
 2. A=No degradation during testing. B = Temporary degradation during testing, but is self-recovering.

Table 3. Typical Performance Specifications<sup>(1)</sup> for Fisher 3611JP and 3621JP Positioners with 585, 585R, 585C, and 585CR Actuators

Characteristic	585C and 585CR Size 25 Actuator <sup>(2)</sup>	585C and 585CR Size 50 Actuator <sup>(2)</sup>	585 and 585R Size 100 Actuator Standard	585 and 585R Size 100 Actuator with Boosters <sup>(3)</sup>
Deadband <sup>(1)</sup>	0.1% of input span	0.1% of input span	0.1% of input span	0.1% of input span
Step Response <sup>(1,4,5)</sup>	0.3 seconds	0.3 seconds	2 seconds	0.3 seconds
Steady-State Air Consumption <sup>(6,7)</sup>	0.01 normal m <sup>3</sup> /min (0.4 scfm)	0.01 normal m <sup>3</sup> /min (0.4 scfm)	0.01 normal m <sup>3</sup> /min (0.4 scfm)	0.01 normal m <sup>3</sup> /min (0.4 scfm)
Hysteresis <sup>(3)</sup>	0.5% of output span	0.5% of output span	0.5% of output span	0.5% of output span
Terminal-Based Linearity <sup>(8)</sup>	1% of output span	1% of output span	1% of output span	1% of output span
Frequency Response <sup>(1)</sup> (-6 dB)	2 Hz	2 Hz	0.2 Hz	2 Hz
Supply Pressure Sensitivity	10% change in supply pressure changes the actuator stem position less than 0.1%			

1. Performance tests are based on 6.9 bar (100 psig) supply pressure and lightest actuator springs. Performance will vary with other pressures and springs.  
 2. Size 25 and 50 actuators tested with appropriate parallel flexure (key 179).  
 3. Equipped with two 2625 boosters with 1/2 inch supply and exhaust ports.  
 4. Step response is the time for the actuator to reach 63 percent of expected travel after a 10 percent step change in input signal.  
 5. 3621JP positioner step response equals 0.4 seconds.  
 6. At 6.9 bar (100 psig) supply pressure. Normal m<sup>3</sup>/min-cubic meters per minute (0°C and 1.01325 bar). Scfm--standard cubic feet per minute (60°F and 14.7 psia).  
 7. 3621JP positioner steady-state air consumption equals 0.02 normal m<sup>3</sup>/min (0.58 scfm).  
 8. 3621JP positioner terminal-based linearity equals ±2.25%.

## Type Number Description

The Fisher 3600 series of positioners include the models listed below.

The following descriptions provide specific information on the different positioner constructions. If the type number is not known, refer to the nameplate on the positioner. For the nameplate location, refer to key 157, figure 26.

**3610J:** A single-acting pneumatic rotary valve positioner for use with Fisher 1051, 1052, and 2052 actuators.

**3610JP:** A double-acting pneumatic rotary valve positioner for use with Fisher 1061 and 1069 rotary actuators, and 585C size 60 and above sliding-stem actuators.

**3611JP:** A double-acting pneumatic sliding-stem valve positioner for use with 585, 585R, 585C, and 585CR for size 25 and 50.

**3620J:** A single-acting electro-pneumatic rotary valve positioner for use with 1051, 1052, and 2052 actuators.

**3620JP:** A double-acting electro-pneumatic rotary valve positioner for use with 1061 and 1069 rotary actuators, and 585C size 60 and above sliding-stem actuators.

**3621JP:** A double-acting electro-pneumatic sliding-stem valve positioner for use with 585, 585R, 585C, and 585CR for size 25 and 50.

**3622:** An electro-pneumatic converter used for conversion of a 4 to 20 milliampere DC input signal to a 0.2 to 1.0 bar (3 to 15 psig) input signal for the pneumatic positioner. Use this unit in combination with a 3610J, 3610JP, or 3611JP positioner to make a 3620J, 3620JP or a 3621JP positioner.

## Specifications

### **⚠ WARNING**

**This product is intended for a specific range of pressure, temperatures and other application specifications. Applying different pressure, temperature and other service conditions could result in malfunction of the product, which could cause property damage or personal injury.**

Specifications for the valve positioners are shown in table 1. Performance specifications for 3611JP and 3621JP positioners are shown in table 3.

## Educational Services

Emerson Automation Solutions  
Educational Services - Registration  
Phone: +1-800-338-8158  
E-mail: education@emerson.com  
emerson.com/mytraining

## Installation

Normally, a positioner is shipped with the actuator. If so, the factory mounts and calibrates the positioner and connects the positioner to actuator tubing. If the positioner is ordered separately from the actuator, perform the appropriate mounting procedure, and follow the Calibration procedures in this instruction manual. Refer to the appropriate instruction manuals for actuator and valve mounting procedures.

### **⚠ WARNING**

Avoid personal injury from sudden release of process pressure. Before mounting the positioner:

- Always wear protective clothing gloves, and eyewear when performing any installation operations to avoid personal injury.
- When installing 3620J, 3620JP, and 3621JP positioners in a hazardous area, turn off control signals until installation is complete. Be sure all safety barriers, connections, and the converter housing cap and O-ring are properly installed before applying a control signal to the unit.
- If installing into an existing application, also refer to the WARNING at the beginning of the Maintenance section.
- Check with your process or safety engineer for any additional measures that must be taken to protect against process media.

### **⚠ WARNING**

Personal injury or property damage may result from fire or explosion if natural gas is used as the supply medium and appropriate preventive measures are not taken. Preventive measures may include, but are not limited to, one or more of the following: Remote venting of the unit, re-evaluating the hazardous area classification, ensuring adequate ventilation, and the removal of any ignition sources.

3620J, 3620JP, 3621JP positioners and the 3622 electro-pneumatic converter do not meet third party approvals for use with natural gas as the supply medium. Use of natural gas as the supply medium can result in personal injury or property damage from fire or explosion.

### **NOTICE**

Do not use sealing tape on pneumatic connections. This instrument contains small passages that may become obstructed by detached sealing tape. Thread sealant paste should be used to seal and lubricate pneumatic threaded connections.

## Hazardous Area Classifications and Special Instructions for “Safe Use” and Installation in Hazardous Locations for 3622 Converter

Certain nameplates may carry more than one approval, and each approval may have unique installation/wiring requirements and/or conditions of “safe use”. These special instructions for “safe use” are in addition to, and may override, the standard installation procedures. Special instructions are listed by approval.

Refer to the following instruction manual supplements for approval information.

- CSA Hazardous Area Approvals - Fisher 3622 Electro-Pneumatic Converter ([D104323X012](#))
- FM Hazardous Area Approvals - Fisher 3622 Electro-Pneumatic Converter ([D104324X012](#))
- ATEX Hazardous Area Approvals - Fisher 3622 Electro-Pneumatic Converter ([D104325X012](#))
- IECEx Hazardous Area Approvals - Fisher 3622 Electro-Pneumatic Converter ([D104326X012](#))

All documents are available from your [Emerson sales office](#) or visit Fisher.com. Contact your Emerson sales office for all other approval/certification information.

## Mounting 3610J and 3620J Positioners on 2052 Actuators

During the following mounting procedures, refer to figure 3 for part locations. Refer to figure 29 for key number locations unless otherwise indicated.

1. Remove the actuator cover plate from the actuator housing.

---

### Note

Cams A, B, and C have the letter D (direct acting) on one side. Always install the cam with the letter D on the same side as the cam mounting screw heads (key 83, figure 3).

---

2. Install the desired cam (key 82) on the actuator lever with the cam mounting screws (key 83). Cams B and C use the cam adjustment indicator (key 84) between the screw heads and the cam. Align the cam adjustment indicator with the desired total valve rotation indication on the cam. Cam A does not use the cam adjustment indicator and does not require adjustment.
3. Remove the positioner cover (key 41) from the positioner. Slide the positioner into the actuator housing so the cam roller (key 39) rests on the cam. Insert and tighten the socket head screws (key 54) to secure the positioner to the actuator housing.
4. Replace the positioner cover (key 41) on positioner.

### **NOTICE**

**To avoid parts damage, do not completely stroke the actuator while the actuator cover is removed.**

---



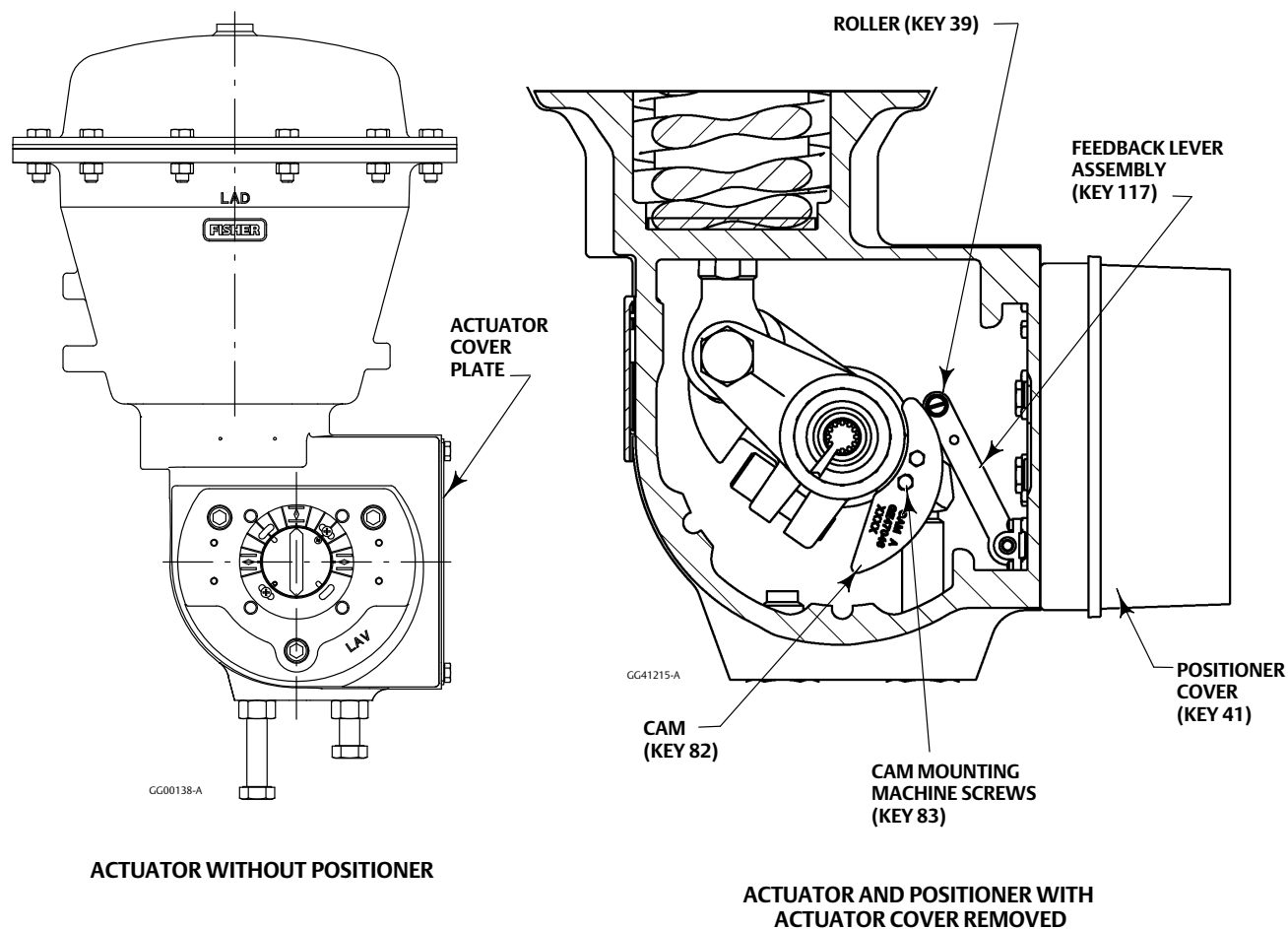
**⚠ WARNING**

To avoid personal injury from moving parts, keep fingers and tools clear while stroking the actuator with the cover removed.

**Note**

The travel stop for 1051 and 1052 actuators are different for 2052 actuators. Refer to the appropriate instruction manual for 1051 and 1052 actuator mounting details.

Figure 3. Typical Mounting Details for Fisher 3610J and 3620J Positioners on 2052 Actuators



---

**Note**

Refer to the appropriate 1061 and 1069 instruction manual or contact your [Emerson sales office](#) for information on mounting on these actuators.

---

## Changing Cams—Actuator Styles A, B, C, and D

During the following procedures, refer to figure 3 for part locations and refer to figure 29 for key number locations unless otherwise indicated. For the different actuator mounting styles, refer to the applicable instruction manual.

1. Remove the actuator cover plate from the actuator housing.
- 

**Note**

Cams A, B, and C have the letter D (direct acting) on one side. Always install the cam with the letter D on the same side as the cam mounting screw heads (key 83, figure 3).

---

2. Uninstall the existing cam (key 82) from the actuator lever by removing the cam mounting screws (key 83).
3. Install the desired cam (key 82) on the actuator lever with the cam mounting screws (key 83). Cams B and C use the cam adjustment indicator (key 84) between the screw heads and the cam. Align the cam adjustment indicator with the desired total valve rotation indication on the cam. Cam A does not use the cam adjustment indicator and does not require adjustment.

**NOTICE**

To avoid parts damage, do not completely stroke the actuator while the actuator cover is removed.

---

**⚠ WARNING**

To avoid personal injury from moving parts, keep fingers and tools clear while stroking the actuator with the cover removed.

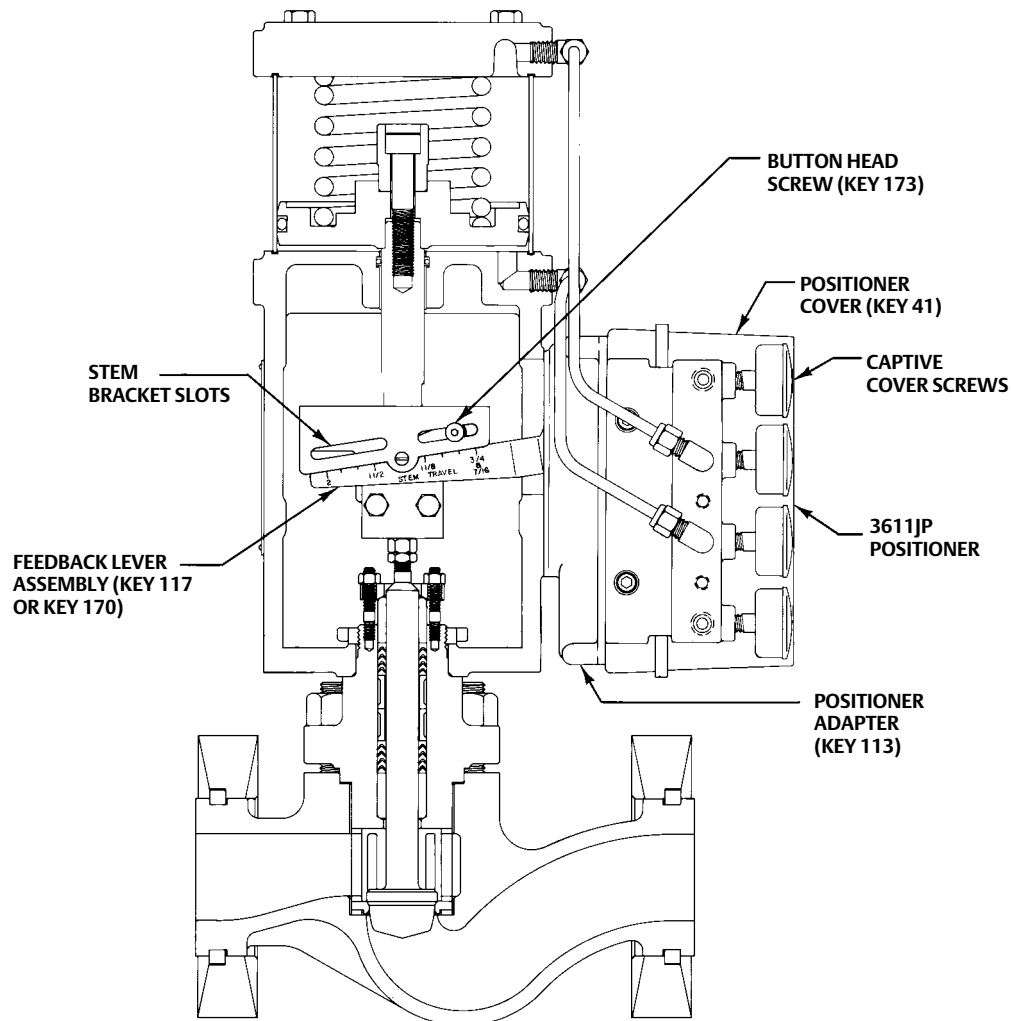
---

4. Replace the actuator cover plate.

## Mounting 3611JP and 3621JP on 585 and 585R Size 100 Actuators

Refer to figure 4 for part locations. Refer to figure 30 for key number locations unless otherwise indicated.

Figure 4. Typical Mounting Details for Fisher 3611JP and 3621JP Positioners on 585 Actuators



CONTROL VALVE ASSEMBLY WITH ACTUATOR FRONT YOKE COVER PLATE REMOVED

49A3788-A  
A3231-2

1. Refer to the appropriate actuator instruction manual. Loosen the four screws, and remove the front yoke cover plate from the actuator.
2. Stroke the actuator from the top stop to the bottom stop, and record the travel distance.
3. Loosen the four captive cover screws and remove the positioner cover (key 41, figure 29).
4. Refer to the appropriate actuator instruction manual. Loosen the four screws, and remove the actuator blanking plate.
5. Attach the positioner adapter (key 113) to the actuator with four socket head screws (key 54).
6. Disconnect the positioner range spring (key 150, figure 26) from the range spring hanger (key 130, figure 26).
7. Attach the roller (key 175) and washers (key 184) to the adjuster assembly (key 174) and secure with the retaining ring (key 172).
8. Apply pressure to the actuator piston and move the actuator to approximately the mid-travel position.
9. Install the positioner on the actuator so the feedback lever assembly (key 170) is under the stem bracket and secure the positioner to the adapter (key 113) with the four socket head screws (key 54).

10. With the actuator still at mid-travel and the top edge of the feedback lever assembly perpendicular to the actuator stem, install the adjuster assembly/roller in the appropriate stem bracket slot with the button head screw (key 173) so the roller is centered over the correct actuator travel marked on the feedback lever assembly (key 170) as shown in figure 4.
11. Tighten the button head screw (key 173) and replace the range spring (key 150, figure 26).
12. For size 100 actuators with greater than a 51 mm (2 inch) travel, install the feedback lever spring (key 185).
13. Replace the positioner cover.
14. Replace the front actuator cover plate.
15. Discard the actuator blanking plate and the four screws.

## Mounting 3611JP and 3621JP on 585C and 585CR Size 25 and 50 Actuators

The 3611JP pneumatic positioner and the 3621JP electro-pneumatic positioner can be mounted on either a 585C or 585CR piston actuator. A positioner adaptor (key 113) attaches to the back of the positioner and serves as the interface to the mounting bracket (key 194). Refer to the 585C and 585CR actuators instruction manual ([D102087X012](#)) for additional information on the actuator.

Refer to figure 5 for parts identification.

1. Stroke the actuator from the top stop to the bottom stop, and record the travel distance.
2. Loosen the four captive cover screws and remove the positioner cover (key 41, figure 29).
3. Mount the stem bracket (key 195) to the actuator with two hex nuts (key 197).
4. Disconnect the positioner range spring (key 150, figure 26) from the range spring hanger (key 130, figure 26).
5. Attach the feedback roller (key 175) to the stem bracket (key 195) with the button head screw (key 173).
6. Attach the positioner adaptor (key 113) to the mounting bracket (key 194) with four hex nuts (key 197) and four hex socket cap screws (key 54).
7. Remove the positioner cover. Attach the 3611JP or 3621JP positioner to the positioner adaptor/mounting bracket assembly with four hex socket cap screws (key 54).
8. Apply pressure to the actuator piston and move the actuator to approximately the mid-travel position.
9. Thread one of the three hex head cap screws (key 196) into the yoke leg threaded hole approximately two (2) turns.
10. Install the assembly from step 7 to the 585C or 585CR actuator by sliding the mounting bracket slot (see figure 6) onto the yoke leg cap screw. As you attach this assembly to the actuator, center the spring-loaded feedback arm under the feedback roller (key 175) on the stem bracket (key 195). Align the mounting bracket top holes (see figure 6) with the cylinder holes and install the remaining two hex head cap screws (key 196). Tighten all screws.
11. With the actuator still at mid travel and the top edge of the feedback lever assembly perpendicular to the actuator stem, install the adjuster assembly/roller in the appropriate stem bracket slot with the button head screw (key 173) so the roller (key 175) is centered over the correct actuator travel marked on the feedback lever assembly.
12. Tighten the feedback roller button head screw (key 173) and replace the range spring (key 150, figure 26).
13. Replace the positioner cover.

Figure 5. Typical Mounting Details for Fisher 3611JP and 3621JP Positioners on 585C Actuator

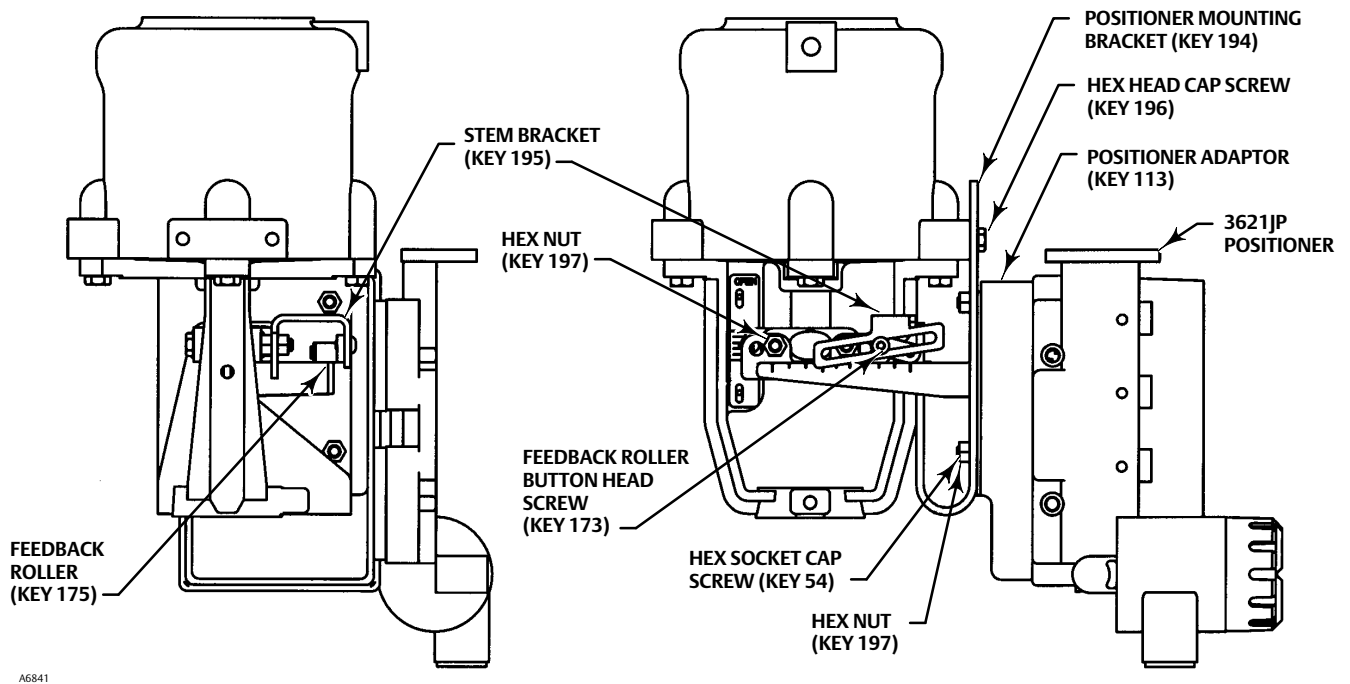
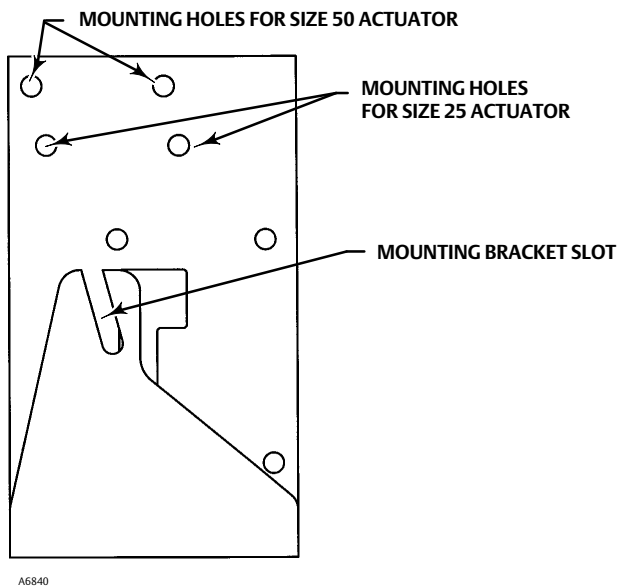


Figure 6. Positioner Mounting Bracket



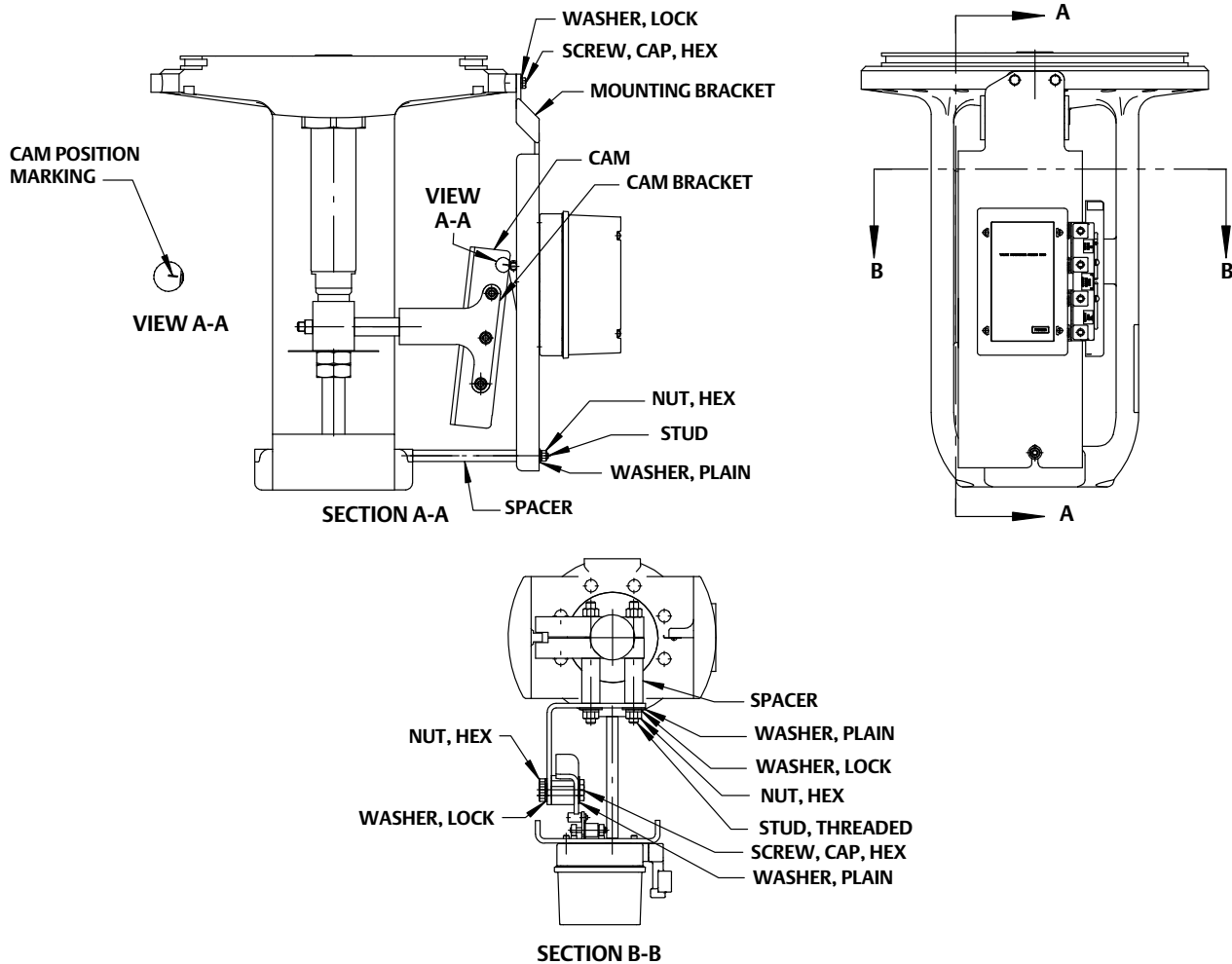
## Mounting 3610JP and 3620JP Positioners on Long Travel Sliding-Stem Actuators

If ordered as part of a control valve assembly, the factory mounts the 3610JP or 3620JP on the actuator, makes pneumatic connections to the actuator, sets up, and calibrates the instrument. If you purchased the 3610JP or 3620JP, or mounting kit separately, you will need to mount the 3610JP or 3620JP on the actuator. See the instructions that come with the mounting kit for detailed information on mounting to a specific actuator model.

3610JP and 3620JP positioners use a cam (designed for linear response) and roller as the feedback mechanism. Figure 7 shows an example of mounting on sliding-stem actuators with long travel.

1. If a cam is not already installed on the sliding-stem actuator, install as described in the drawing instructions included with the mounting kit.

Figure 7. Typical Mounting Details for Fisher 3610JP and 3620JP Positioners on Long Travel Sliding-Stem Actuators



2. Install the mounting plate and fasten it to the actuator. Stroke the actuator from the top stop to the bottom stop and record the travel distance.
3. Remove the positioner cover (key 41, figure 29) by loosening the four captive cover screws.
4. Attach the 3611JP or 3621JP positioner to the positioner mounting bracket assembly with four hex socket cap screws (key 54).
5. Apply pressure to the actuator piston and move the actuator to the top position. Check that roller aligns with the position mark on the cam (see figure 7); if it does not align, adjust the cam position.
6. Replace the positioner cover.

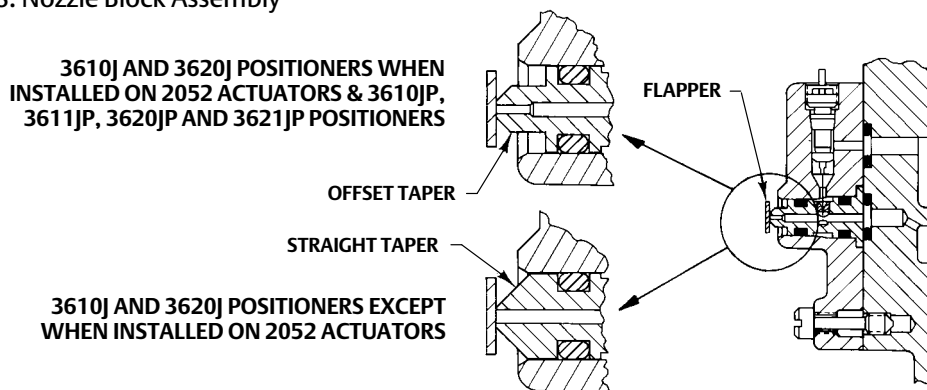
## Installing the 3622 Electro-Pneumatic Converter

If installing the converter on an existing pneumatic positioner, refer to the Gauge Block Disassembly procedures in the Maintenance section. The converter module replaces the original pneumatic gauge block. Refer to the 3622 Electro-pneumatic Converter Assembly procedure to install the converter. When calibrating the electro-pneumatic positioner for a 4 to 20 milliampere DC input range, use the range spring hole that corresponds to a 0.2 to 1.0 bar (3 to 15 psig) input range [0.8 bar (12 psig) span]. See tables 6 and 7 and figure 16 for the range spring and range spring hole selection.

## Changing Positioner Types

All 3610J and 3620J positioners have the same basic construction. For 3611JP or 3621JP, a parallel flexure (key 179, figure 14) is added (not required on 585 size 100 actuator). When changing positioner types, other parts may require changing, such as the nozzle assembly (key 116, figure 26), the feedback lever assembly (key 117 or 170, figure 30), and the range spring (key 150, figure 26). Refer to the Parts List for part number identification. Changing parts may require partial disassembly and reassembly as described in the Maintenance section. Figure 8 illustrates the slight difference in nozzle assemblies between the single-acting (3610J and 3620J) and double-acting (3610JP, 3620JP, 3611JP and 3621JP) positioners. See the Changing Positioner Types procedure in the Maintenance section for additional information.

Figure 8. Nozzle Block Assembly



36A5654-A  
A3234-1

## Pressure Connections

### **⚠ WARNING**

The positioner is capable of providing full supply pressure to connected equipment. To avoid personal injury or equipment damage caused by parts bursting from system overpressure, make sure the supply pressure never exceeds the maximum safe working pressure of any connected equipment.

### **NOTICE**

Do not use sealing tape on pneumatic connections. This instrument contains small passages that may become obstructed by detached sealing tape. Thread sealant paste should be used to seal and lubricate pneumatic threaded connections.

To complete the installation of a 3610J or 3620J positioner requires connecting tubing and fittings between the positioner and the actuator. The fittings, tubing, and mounting parts required depend on the type number and optional equipment: such as filter, regulator, and bypass valve. Positioner pressure connection locations are shown in figure 9. All pressure connections to the 3610J and 3620J positioners are 1/4 NPT internal. Use 3/8-inch tubing or 1/4-inch pipe for all tubing connections. Refer to the Vent Connection section for remote vent connections.

## Supply Connection

### **⚠ WARNING**

Severe personal injury or property damage may occur from process instability if the instrument supply medium is not clean, dry and oil-free air, and noncorrosive gas. While use and regular maintenance of a filter that removes particles larger than 40 micrometers in diameter will suffice in most applications, check with an Emerson field office and industry instrument air quality standards for use with corrosive gas or if you are unsure about the proper amount or method of air filtration or filter maintenance.

### **⚠ WARNING**

3620J, 3620JP, 3621JP positioners and the 3622 electro-pneumatic converter do not meet third party approvals for use with natural gas as the supply medium. Use of natural gas as the supply medium can result in personal injury or property damage from fire or explosion.

Supply pressure must be clean, dry, and oil-free air or noncorrosive gas. Use of a 67CFR filter regulator with standard 5 micrometer filter, or equivalent, to filter and regulate supply air should suffice in most applications. The 67CFR filter regulator can be integrally mounted with the positioner. Use 3/8-inch tubing or 1/4-inch pipe for the supply line.

### **NOTICE**

To avoid equipment damage caused by excessive pressure, do not exceed the maximum pressure rating of the actuator or positioner. Refer to the appropriate instruction manual to determine the maximum pressure rating of the actuator, and to table 1 for the maximum pressure rating of the positioner.



The supply pressure should be high enough to permit setting the regulator 0.3 bar (5 psi) above the upper limit of the appropriate pressure range, for example: 1.4 bar (20 psig) for a 0.2 to 1.0 bar (3 to 15 psig) range. However, do not exceed the maximum allowable supply pressure of 10.3 bar (150 psig) nor the pressure rating of any connected equipment.

### Output Connections

For the 3610J or 3620J positioner, the OUTPUT A connection must be plugged. Connect the OUTPUT B connection to the actuator diaphragm casing connection. Figure 9 shows a positioner with a bypass valve. When the bypass valve is used, connect the OUTPUT connection on the bypass valve to the diaphragm casing connection on the actuator. A manifold in the bypass body adapter internally connects OUTPUT B to the bypass valve.

Figure 9. Typical Mounting Dimensions and Connections

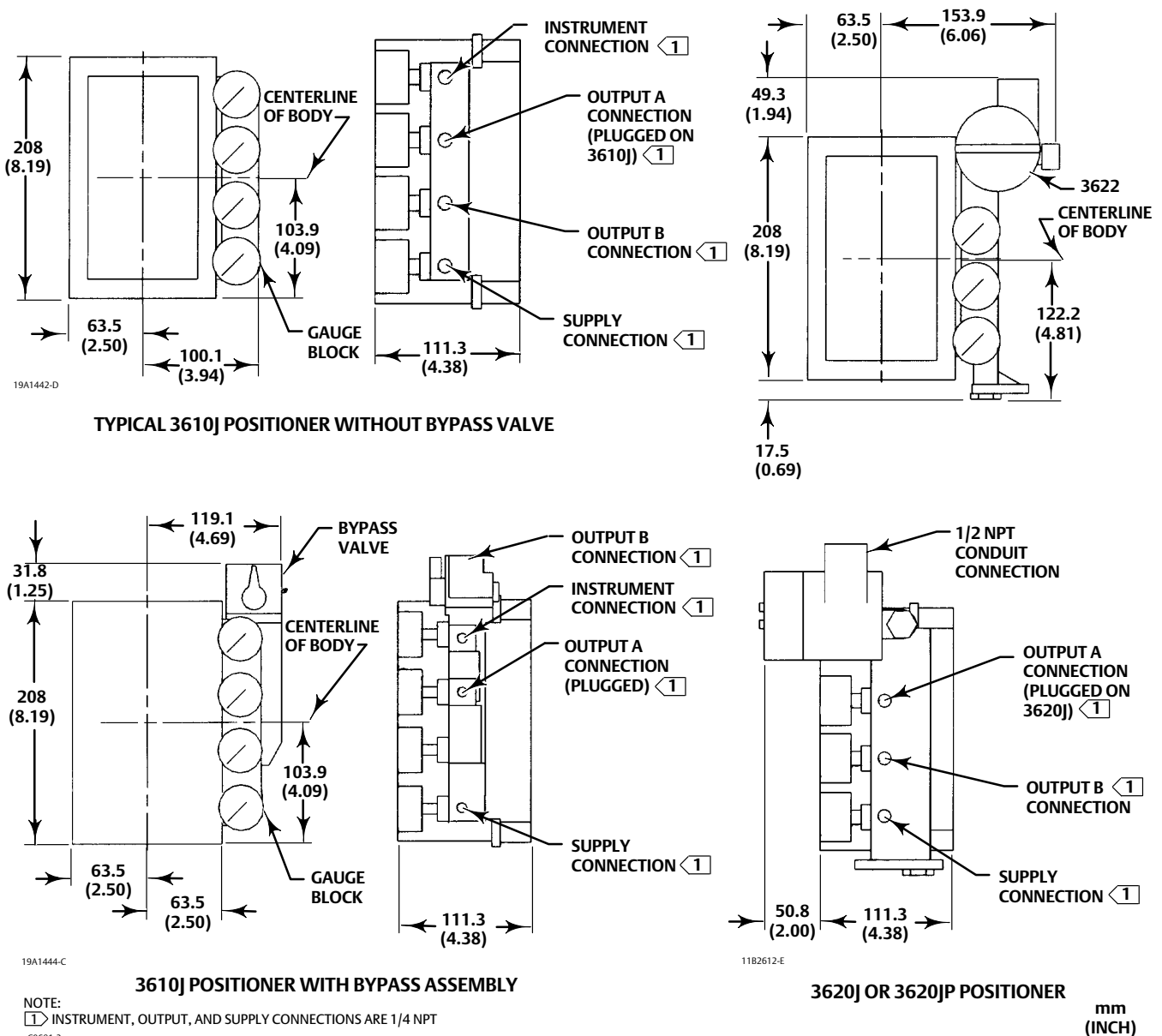
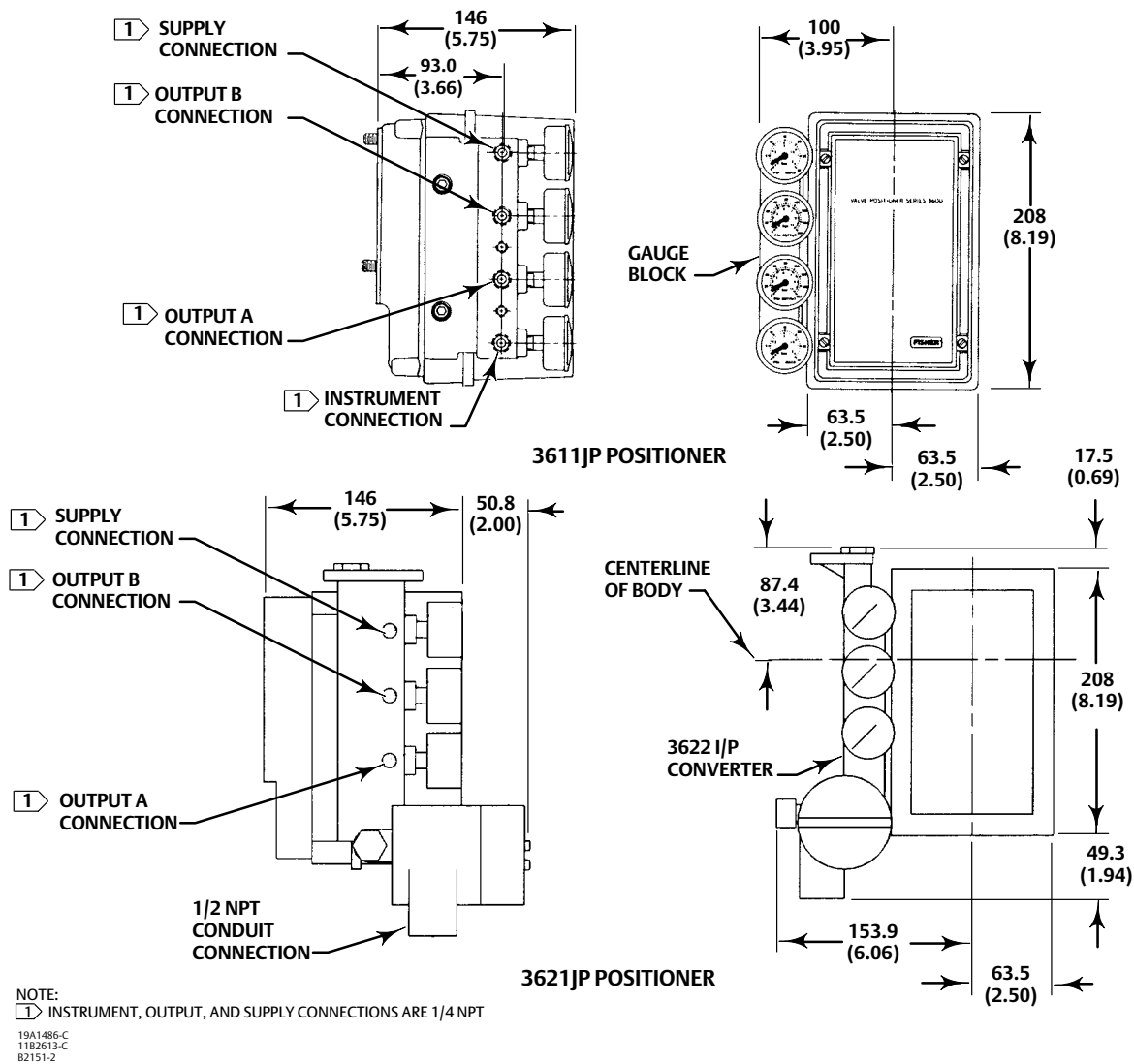


Figure 9. Typical Mounting Dimensions and Connections (Continued)



Use 3/8-inch tubing between the actuator and the positioner.

For the 3610JP or 3620JP positioner, connect the OUTPUT A connection to the lower actuator cylinder connection and the OUTPUT B connection to the upper actuator cylinder connection. Figure 1 shows the positioner connected to a piston actuator. Use 3/8-inch tubing between the actuator and positioner.

For the 3611JP or 3621JP positioner, connect the OUTPUT A connection to the lower actuator cylinder connection and the OUTPUT B connection to the upper actuator cylinder connection. Figure 2 shows the positioner connected to a 585C actuator. Use 3/8-inch tubing between the actuator and the positioner.

### Instrument Connection

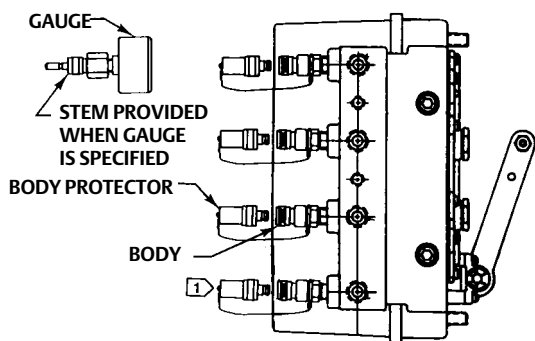
Use 3/8-inch tubing to connect the output from the control device to the INSTRUMENT connection on a pneumatic positioner. For the electro-pneumatic positioner, refer to the Electrical Connections section.

## Diagnostic Connections

To support diagnostic testing of valve/actuator/positioner/accessory packages, special connectors and hardware are available. The hardware used includes 1/8 NPT connector bodies and body protectors. If the diagnostic connectors are ordered for a positioner with gauges, 1/8-inch stems are also included.

Install the connectors on the 3610J positioner gauge block or bypass block assembly as shown in figure 10. For 3620J positioners, install the connectors on the 3622 housing as shown in figure 11. Before installing the connectors on the positioner, apply sealant to the threads. Sealant is provided with the diagnostic connections and hardware.

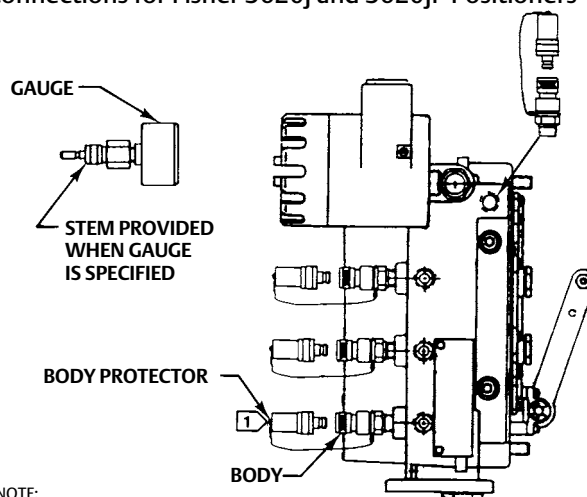
Figure 10. FlowScanner™ Diagnostic System Connections for Fisher 3610J and 3610JP Positioners



NOTE:  
 1 BODY PROTECTOR AND BODY NOT REQUIRED WITH THE 3610J POSITIONER.

1288050-A  
 A6081-1

Figure 11. FlowScanner Diagnostic System Connections for Fisher 3620J and 3620JP Positioners



NOTE:  
 1 BODY PROTECTOR AND BODY NOT REQUIRED WITH THE 3620J POSITIONER.

1288051-B  
 A6083-1

## Vent Connection

3610J and 3620J positioner relays exhaust actuator pressure through the positioner case and into the 1051, 1052, 1061, and 1069 actuator housings. These actuator housings provide a 1/4 NPT connection and a screen is normally installed in this connection to prevent blockage from debris or insects. Restricting this vent area can produce a pressure buildup in the case and degrade positioner performance. There is also a 1/4 NPT connection on the 3622 converter housing where the vent (key 28) is installed. 585, 585R, 585C, and 585CR actuators do not have a 1/4-inch vent connection.

### **⚠ WARNING**

Personal injury or property damage could result from fire or explosion of accumulated gas if a flammable gas is used as the supply pressure medium and the positioner/actuator is in an enclosed area. The positioner/actuator assembly does not form a gas-tight seal, and a remote vent line is recommended. However, a remote vent line cannot be relied upon to remove all hazardous gas, and leaks may still occur. Provide adequate ventilation and necessary safety measures. Vent line piping should comply with local and regional codes and should be as short as possible with adequate inside diameter and few bends to reduce case pressure buildup.

**⚠ WARNING**

3620J, 3620JP, 3621JP positioners and the 3622 electro-pneumatic converter do not meet third party approvals for use with natural gas as the supply medium. Use of natural gas as the supply medium can result in personal injury or property damage from fire or explosion.

If a remote vent is required, the vent line must be as short as possible with a minimum number of bends and elbows. Vent line piping should have a minimum inside diameter of 19 mm (3/4 inches) for runs up to 6.1 m (20 feet) and a minimum inside diameter of 25 mm (1 inch) for runs from 6.1 to 30.5 meters (20 to 100 feet).

## Electrical Connection for 3620J Positioners

**⚠ WARNING**

Personal injury or property damage may result from fire or explosion if power is not disconnected before removing the 3622 converter cap.

For Class I, Division 1 explosion-proof applications, install rigid metal conduit and a conduit seal no more than 457 mm (18 inches) from the 3622 converter. Personal injury or property damage may result from explosion if the seal is not installed.

For intrinsically-safe installations, refer to the loop schematics included in the appropriate Hazardous Area Approval Supplement (CSA, [D104323X012](#) or FM, [D104324X012](#)) or to instructions provided by the barrier manufacturer for proper wiring and installation.

Select wiring and/or cable glands that are rated for the environment of use (such as hazardous area, ingress protection and temperature). Failure to use properly rated wiring and/or cable glands can result in personal injury or property damage from fire or explosion.

Wiring connections must be in accordance with local, regional, and national codes for any given hazardous area approval. Failure to follow the local, regional, and national codes could result in personal injury or property damage from fire or explosion.

Use the 1/2-14 NPT conduit connection for field wiring installation. Refer to figures 12 and 13 when connecting field wiring from the control device to the converter. Connect the positive wire from the control device to the converter + terminal and the negative wire from the control device to the converter - terminal. Do not overtighten the terminal screws. Maximum torque is 0.45 N•m (4 lbf•in).

Figure 12. Fisher 3622 Converter Equivalent Circuit

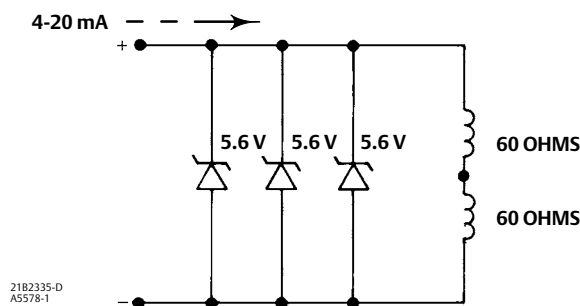
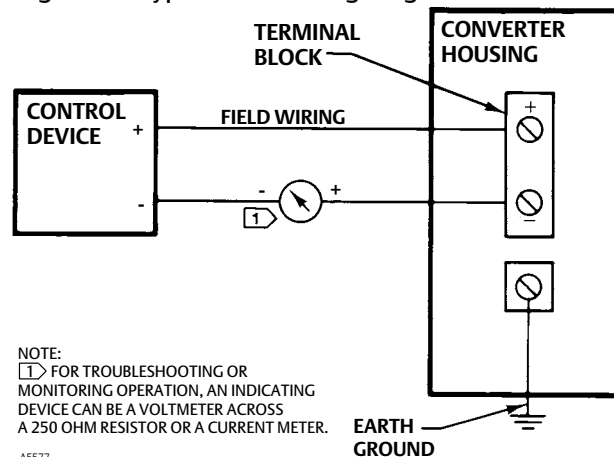


Figure 13. Typical Field Wiring Diagram



## Calibration

The following calibration procedures are for pneumatic positioner adjustment. For 3620J, 3620JP, or 3621JP positioners, there are no adjustments within the converter portion of the positioner. All adjustments are accomplished within the pneumatic portion of the positioner.

### **⚠ WARNING**

**During calibration the valve may move. To avoid personal injury or property damage caused by the release of pressure or process fluid, provide some temporary means of control for the process.**

Refer to figure 26 for key number locations. Adjustments are shown in figure 14.

## Minor Loop Gain Adjustment

The minor loop gain adjustment varies the dynamic gain of the positioner to match the specific size and characteristic of the actuator. This adjustment allows tuning of the positioner transient response to the application without significantly affecting the static operating performance.

The minor loop gain adjustment is factory set for a positioner shipped with the actuator. However, additional adjustment should be made to suit the particular application requirement. The minor loop gain also may require adjustment if:

- the positioner was not installed on the actuator by the factory,
- installing the positioner on an actuator other than the type for which the positioner was originally set up,
- maintenance was performed on the positioner.

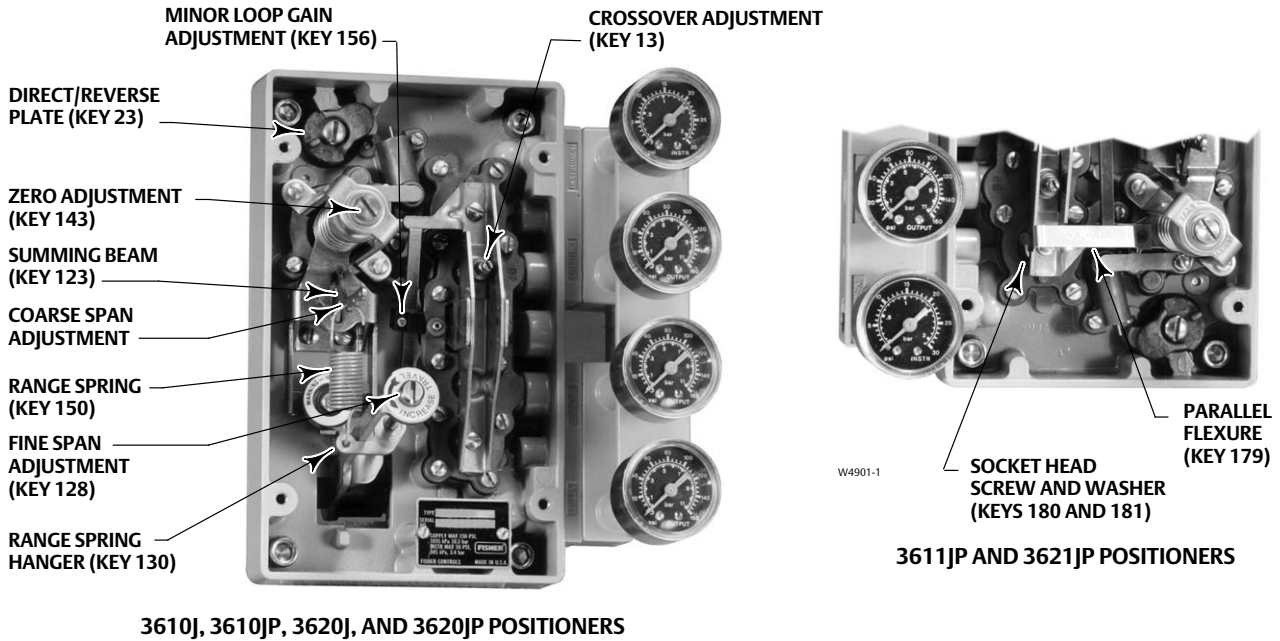
The minor loop gain should be adjusted before performing the other calibration procedures.

Figure 14 shows the minor loop gain adjustment location. As shown in figure 15, the adjustment is made by moving the flexure adjustment (key 156) along the top flexure.

The table in figure 15 and a label inside the positioner cover (key 41, figure 29) recommend flexure adjustment starting positions for various actuator types. Start with the flexure adjustment set to the recommended starting distance from the gain adjustment plate, the X dimension in figure 15. To adjust the minor loop gain, proceed as follows:

1. Unscrew the four captive cover screws and remove the cover (key 41, figure 29).
2. Refer to figures 14 and 15 and identify the gain adjustment plate, the flexure adjustment (key 156), and the X dimension between the plate and the adjustment.

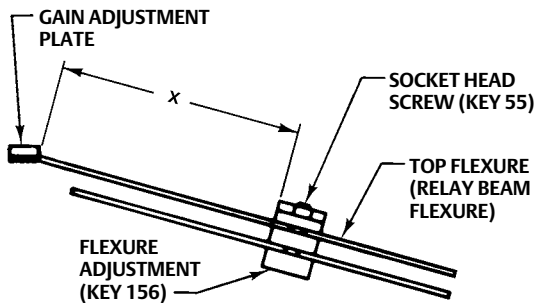
Figure 14. Calibration Adjustments



W4900-1

3. Loosen the flexure adjustment socket head screw (key 55, figure 15) and slide the flexure adjustment on the flexures to increase or decrease the X dimension. Moving the flexure adjustment in the direction of the arrow on the top flexure (decreasing the X dimension) slows the positioner response. Moving the flexure adjustment in the opposite direction speeds up the positioner response.
4. Tighten the flexure adjustment screw and check the positioner response. Repeat step 3 if readjustment is required.
5. If this is the only adjustment, replace the cover. If not, continue with the Crossover Adjustment.

Figure 15. Minor Loop Gain Adjustment



20B1277-E  
A3233-2

Actuator	"X" Dimension	
	mm	Inches
1052/20, 2052/1	22	7/8
1051, 1052/30, 33, and 40, 2052/2	24	15/16
1051, 1052/60	35	1-3/8
1052/70	38	1-1/2
2052/3	37	1-7/16
1061/30	21	13/16
1061/40	22	7/8
1061/60	24	15/16
1061/80	27	1-1/16
1061/100	29	1-1/8
1069/100	44	1-3/4
585C/25 and 50 585/100	33	1-5/16

## Crossover Adjustment

Perform one or the other of the following procedures, depending on the positioner and actuator type. When finished with the crossover adjustment, proceed to the zero and span adjustments.

### Spring and Diaphragm Actuators (3610J or 3620J Positioners)

---

**Note**

Do not perform these steps 1 through 6 if calibrating a 3610JP, 3611JP, 3620JP, or 3621JP positioner. These 6 steps are only applicable to 3610J and 3620J positioners used on spring and diaphragm actuators.

---

1. Unscrew the four captive cover screws and remove the cover (key 41, figure 29).
2. If the positioner does not have pressure gauges, connect a pressure gauge to OUTPUT A.
3. Apply supply pressure.
4. Apply an input signal (pneumatic or electrical) to the positioner to position the actuator at approximately mid-travel. If necessary, you can use the zero adjustment to position the actuator at approximately mid-travel. The actuator should not be under load during crossover adjustment.

---

**Note**

Large step changes may cause the supply pressure gauge reading to momentarily drop.

---

5. Using a screwdriver, turn the crossover adjusting screw (key 13, figure 14) counterclockwise until the OUTPUT A pressure gauge reads zero pressure; then turn it clockwise until full supply pressure is obtained. Once supply pressure is obtained, turn the adjusting screw an additional four, 360-degree turns clockwise. The gauge should read supply pressure.
6. Continue calibration by performing the zero and span adjustments.

### Piston Actuators (3610JP, 3611JP, 3620JP, or 3621JP Positioners)

---

**Note**

Do not perform these steps 1 through 6 if calibrating a 3610J or 3620J positioner. These 6 steps are only applicable to 3610JP, 3611JP, 3620JP, and 3621JP positioners used on piston actuators.

---

1. Unscrew the four captive cover screws and remove the cover (key 41, figure 29).
2. If the positioner does not have pressure gauges, connect pressure gauges to OUTPUT A and OUTPUT B.
3. Apply supply pressure.

- Apply an input signal (pneumatic or electrical) to the positioner to position the actuator at approximately mid-travel. If necessary, you can use the zero adjustment to position the actuator at approximately mid-travel. The actuator should not be under load during crossover adjustment.

**Note**

Large step changes may cause the supply pressure gauge reading to momentarily drop.

- Using a screwdriver, turn the crossover adjusting screw (key 13) until the sum of the OUTPUT A and OUTPUT B pressures is 140 to 160 percent of supply pressure. Clockwise rotation increases the OUTPUT A and OUTPUT B pressures.

**Note**

Make sure that neither the OUTPUT A pressure or the OUTPUT B pressure equal the supply pressure when adjusting the crossover screw. If either pressure is equal to supply, an accurate crossover setting cannot be achieved. This may occur with the 3611JP or 3621JP positioner due to the spring(s) in the 585, 585R, 585C, 585CR, or other piston actuator. If one of the cylinder pressures equals supply pressure when adjusting the crossover, do one or both of the following:

- Move the actuator to some position other than mid-travel. This new position must be in the direction which decreases the difference between OUTPUT A and OUTPUT B (the direction which reduces compression of the actuator springs). The actuator or valve must not be contacting a stop, but must be somewhere between the up and down stops. With the lower differential between the OUTPUT A and OUTPUT B pressures, adjusting the crossover with neither the OUTPUT A pressure or OUTPUT B pressure equal to supply pressure should be possible. If not, the supply pressure must be increased.
  - Increase supply pressure noting the limitations in the Supply Connection section and repeat the cross-over adjustment. The actuator or valve must not contact the stop, but must be somewhere between the up and down stops. Increase supply pressure sufficiently, so that a crossover setting can be achieved with neither cylinder output pressure equal to supply pressure.
- Continue calibration by performing the zero and span adjustments.

## Zero and Span Adjustments

- Unscrew the four captive cover screws, and remove the cover (key 41, figure 29).
- Use tables 4 through 7 and figure 16 to select the desired range spring and coarse span adjustment. (The tables and figure 16 are only valid for the standard valve travel/range spring combinations shown.) Insert one end of the range spring (key 150, figure 26) into the hole on the range spring hanger (key 130) as shown in figure 16. Insert the other end of the range spring into the hole selected on the summing beam assembly (key 123, figure 16).

Table 4. Fisher 3610J and 3610JP Positioner Range Spring Selection and Coarse Span Adjustment<sup>(1)</sup>

Valve Rotation (Degrees)	Input Span <sup>(2)</sup>									
	0.8 bar (12 psi)		1.7 bar (24 psi)		0.3 bar (4 psi)		0.4 bar (6 psi)		0.6 bar (8 psi)	
	Range Spring	Hole Number	Range Spring	Hole Number	Range Spring	Hole Number	Range Spring	Hole Number	Range Spring	Hole Number
90	Blue	3	Blue	5	Blue	1	Blue	2	Blue	3
75	Yellow	4	Red	4	Yellow	2	Yellow	3	Yellow	3
60	Red	3	Red	5	Red	1	Red	2	Red	3

1. For positioners mounted on 1051, 1052, 1061 and 1069 actuators.

2. This table is only valid for the valve rotation and range spring combinations listed. Contact your [Emerson sales office](#) for rotations or input spans not shown for the valve rotation/range spring combination.



Table 5. Fisher 3611JP Positioner Range Spring Selection and Coarse Span Adjustment<sup>(1)</sup>

Valve Travel mm (Inches)	Input Span <sup>(2)</sup>									
	0.8 bar (12 psi)		1.7 bar (24 psi)		0.3 bar (4 psi)		0.4 bar (6 psi)		0.6 bar (8 psi)	
	Range Spring	Hole Number	Range Spring	Hole Number	Range Spring	Hole Number	Range Spring	Hole Number	Range Spring	Hole Number
11 (0.4375)	Blue	4	Red	5	Red	1	Red	2	Red	3
14 (0.5625)	Blue	4	Red	5	Red	1	Red	2	Red	2
19 to 51 (0.75 to 2)	Blue	3	Yellow	5	Yellow	1	Yellow	2	Yellow	3
51 to 102 (2 to 4) <sup>(3)</sup>	Blue	3	Yellow	5	Yellow	1	Yellow	2	Yellow	3
Other piston actuator with cam feedback	Blue	3	Blue	5	Blue	1	Blue	2	Blue	3

1. For positioners mounted on 585, 585R, 585C and 585CR actuators.  
 2. This table is only valid for the valve travel and range spring combinations listed. Contact your Emerson sales office for travels or input spans not shown for the valve travel/range spring combination.  
 3. For 585 actuator, size 100 only

Table 6. Fisher 3620J and 3620JP Positioner Range Spring Selection and Coarse Span Adjustment<sup>(1)</sup>

Valve Rotation (Degrees)	Input Span <sup>(2)</sup>					
	16 mA		5.3 mA		8 mA	
	Range Spring	Hole Number	Range Spring	Hole Number	Range Spring	Hole Number
90	Blue	3	Blue	1	Blue	2
75	Yellow	4	Yellow	2	Yellow	3
60	Red	3	Red	1	Red	2

1. For positioners mounted on 1051, 1052, 1061 and 1069 actuators.  
 2. This table is only valid for the valve rotation and range spring combinations listed. Contact your Emerson sales office for rotations or input spans not shown for the valve rotation/range spring combination.

Table 7. Fisher 3621JP Positioner Range Spring Selection and Coarse Span Adjustment<sup>(1)</sup>

Valve Travel mm (Inches)	Input Span <sup>(2)</sup>					
	16 mA		5.3 mA		8 mA	
	Range Spring	Hole Number	Range Spring	Hole Number	Range Spring	Hole Number
11 (0.4375)	Blue	4	Red	1	Red	2
14 (0.5625)	Blue	4	Red	1	Red	2
19 to 51 (0.75 to 2)	Blue	3	Yellow	1	Yellow	2
51 to 102 (2 to 4) <sup>(3)</sup>	Blue	3	Yellow	1	Yellow	2
Other piston actuators with cam feedback	Blue	3	Blue	1	Blue	2

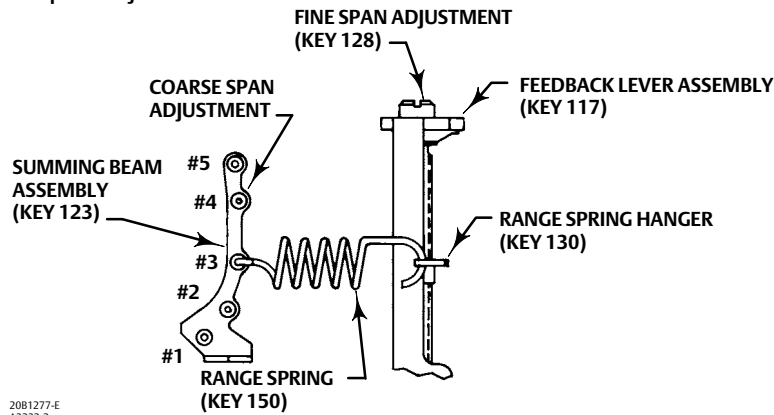
1. For positioners mounted on 585, 585R, 585C, and 585CR actuators.  
 2. This table is only valid for the valve travel and range spring combinations listed. Contact your [Emerson sales office](#) for travels or input spans not shown for the valve travel/range spring combination.  
 3. For the 585 actuator, size 100 only

**Note**

Be sure the range spring hanger (key 130) passes under the feedback lever assembly (key 117) as shown in figure 16.

3. Apply supply pressure.
4. Apply an input signal equal to the low value of the input signal range; for example, if the input signal range is 0.2 to 1.0 bar (3 to 15 psig), apply 0.2 bar (3 psig.)
5. Rotate the zero adjustment screw (key 143, figure 14) until the actuator is at the starting point position (fully up or down depending on the action selected) corresponding to the low input signal. Clockwise rotation of the zero adjustment screw retracts the actuator stem.

Figure 16. Span Adjustment



6. Slowly increase the input signal toward the high end of the input signal range and observe the actuator stroke. If the actuator stroke is short of its expected range, increase the travel by rotating the fine span adjustment screw (key 128, figure 14) counterclockwise with a screwdriver. If the actuator reaches the end of its desired travel with an input signal less than the high value of the input signal range, decrease the travel by rotating the fine span adjustment screw clockwise with a screwdriver.
7. Repeat steps 4, 5, and 6 until the actuator stroke corresponds to the input signal range.
8. Replace the cover on the positioner.

## Changing Positioner Action

This section explains how to change the positioner action from direct to reverse or reverse to direct. With direct action, the actuator stem extends as the input signal to the positioner increases. With reverse action, the actuator stem retracts as the input signal to the positioner increases.

### **⚠ WARNING**

**Avoid personal injury or equipment damage from sudden release of process fluid and improper valve operation. Before reversing the action:**

- Wear protective clothing, gloves, and eyewear whenever possible.
- Do not remove the actuator from the valve while the valve is still pressurized.
- Disconnect any operating lines providing air pressure, or a control signal to the actuator. Be sure the actuator cannot suddenly open or close the valve.
- When disconnecting any of the pneumatic connections, natural gas, if used as the supply medium, will seep from the unit and any connected equipment into the surrounding atmosphere. Personal injury or property damage may result from fire or explosion if appropriate preventative measures are not taken, such as adequate ventilation and the removal of any ignition sources.
- Use bypass valves or completely shut off the process to isolate the valve from process pressure.
- Vent the actuator loading pressure and disconnect positioner supply pressure.
- Use lock-out procedures to be sure that the above measures stay in effect while you work on the equipment.
- Check with your process or safety engineer for any additional measures that must be taken to protect against process media.

### Changing to Direct Action

1. Unscrew the four captive cover screws, and remove the cover (key 41, figure 29).

2. Loosen the reversing plate screw (key 49, figure 26), and adjust the reversing plate (key 23, figure 14) to expose the letter D and cover the letter R. Tighten the screw.

---

**Note**

Direct acting 3610J and 3620J positioners require use of the counter spring (key 125, figure 26). Reverse acting 3610J and 3620J positioners set up for 60 degree valve rotation, or reverse acting 3611JP and 3621JP positioners set up for 11 mm (7/16-inch) actuator travel do not require use of the counter spring. Refer to the parts list for the counter spring part number to be ordered.

---

3. Refer to the note above to determine if a counter spring is needed. If a counter spring is required, install the counter spring (key 125, figure 26) by first removing the machine screw (key 127, figure 26), and the spring seat (key 126, figure 26). Then install the counter spring and replace the spring seat and machine screw.
4. If using characterized cam B or C, refer to the Changing Cams procedures.
5. Perform the Zero and Span adjustment procedure.
6. Replace the cover.

## Changing to Reverse Action

**NOTICE**

**Do not use bypass when the valve positioner is reverse-acting. In this case, bypassing the valve positioner sends the input signal directly to the actuator. Such a change will affect the desired operation and possibly upset the system. Use bypass only when the input signal range is the same as the valve positioner range required for normal actuator operation.**

---

1. Unscrew the four captive cover screws, and remove the cover (key 41, figure 29).
2. Loosen the reversing plate screw (key 49, figure 26), and adjust the reversing plate (key 23, figure 14) to expose the letter R and cover the letter D.
3. For 3610J and 3620J positioners set up for 60 degree valve rotation, or 3611JP and 3621JP positioners set up for 11 mm (7/16-inch) actuator travel or less, a change to reverse action also requires that the counter spring (key 125, figure 26) be removed and discarded. To remove the counterspring, remove the machine screw (key 127, figure 26), the spring seat (key 126, figure 26), and the counter spring (key 125, figure 26). Then replace the spring seat and machine screw.
4. If using characterized cam B or C, refer to the Changing Cams procedures.
5. Perform the Zero and Span adjustment procedure.
6. Replace the cover.

## Split-Range Operation

**NOTICE**

**Do not use bypass when the valve positioner is in split-range operation. In this case, bypassing the valve positioner sends the input signal directly to the actuator. Such a change will affect the desired operation and possibly upset the system. Use bypass only when the input signal range is the same as the valve positioner range required for normal actuator operation.**

---

Split-range operation is possible with 3610J and 3620J positioners. With split-range operation, the input signal from a single control device is split between two or three control valves. The positioners will fully stroke the actuator with an input signal span of 0.2 bar (3.2 psig) minimum to 2.0 bar (28.8 psig).

The zero adjustment of the positioner is continuously adjustable between 0.07 to 1.5 bar (1 and 22 psig).

Table 8 shows some typical split ranges for the positioners. Refer to tables 4 through 7 and figure 16 for the correct range spring and range spring hole selection for the desired coarse span adjustment. Contact your [Emerson sales office](#) for input signal ranges not shown in table 8.

#### Note

The following is an example of range spring and range spring hole selection in tables 4 through 7. Assume a 0.2 to 0.6 bar (3 to 9 psig) input. This is equivalent to a span of 0.4 bar (6 psi) [0.6 bar - 0.2 bar = 0.4 bar (9 psig - 3 psig = 6 psi)]. Therefore for a 90 degree valve rotation and a span of 0.4 bar (6 psi), select a blue range spring. Place the range spring in hole number 2 on the summing beam assembly.

Table 8. Split-Ranging Capabilities

3610J Positioners <sup>(1)</sup>				
Split	0.2 to 1.0 Bar or 3 to 15 Psig Input Signal		0.4 to 2.0 Bar or 6 to 30 Psig Input Signal	
	Bar	Psig	Bar	Psig
Two-way	0.2 to 0.6 0.6 to 1.0	3 to 9 9 to 15	0.4 to 1.2 1.2 to 2.0	6 to 18 18 to 30
Three-way	0.2 to 0.5 0.5 to 0.7 0.7 to 1.0	3 to 7 7 to 11 11 to 15	0.4 to 0.9 0.9 to 1.5 1.5 to 2.0	6 to 14 14 to 22 22 to 30
3620J Positioners <sup>(1)</sup>				
Split	4 to 20 Milliampere DC Input Signal			
Two-way	4 to 12 12 to 20			
Three-way	4 to 9.3 9.3 to 14.7 14.7 to 20			

1. This table is only valid for the standard valve rotation or travel and range spring combinations listed in tables 4 through 7. Contact your [Emerson sales office](#) for input signal ranges not listed.

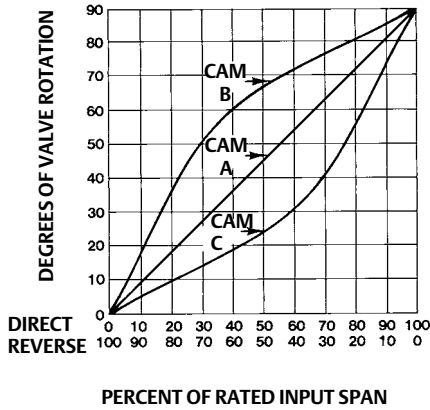
## Characterized Cams for 3610J, 3610JP, 3620J, and 3620JP Positioners

3610J, 3610JP, 3620J, and 3620JP positioners are available with any one of three cams: a linear cam (cam A) and two characterized cams (cams B and C).

When the linear cam is used, there is a linear relationship between an incremental input signal change and the resultant valve rotation. The flow characteristic is that of the control valve.

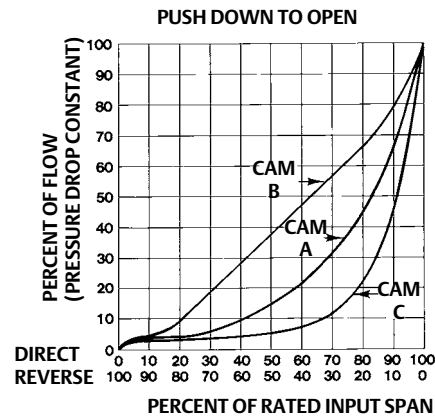
When either of the characterized cams are used, the relationship between an incremental input signal change and the valve rotation is changed. Curves illustrating the relationship between the input signal and the valve rotation, and between the input signal and the flow characteristic of an equal percentage valve, are shown in figures 17, 18, and 19.

Figure 17. Input Signal Versus Valve Rotation



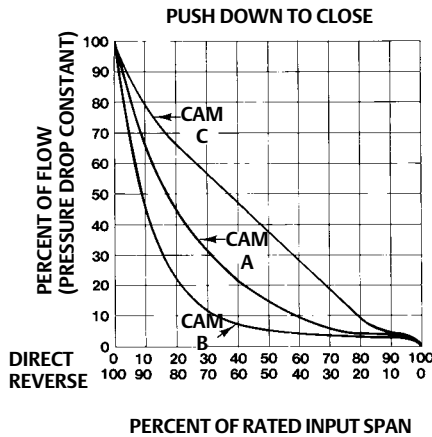
A2264-2

Figure 18. Flow Characteristics for the Various Cams When Used With an Equal Percentage Valve Characteristic, Push-Down-to-Open Valve



33A4959-A  
A1581-3

Figure 19. Flow Characteristics for the Various Cams When Used With an Equal Percentage Valve Characteristic Push-Down-to-Close Valve



33A4960-A  
A1582-3

## Principle of Operation

3610J positioners accept a pneumatic input signal and 3620J positioners accept a DC current input signal from a control device. 3620J electro-pneumatic positioners use a 3622 converter to provide a pneumatic input to the pneumatic portion (3610J) of the positioner. 3610J positioners are force-balanced instruments that provide a control valve position proportional to the pneumatic input signal. The following describes the principle of operation for 3610JP and 3620JP positioners. The principle of operation for 3610J and 3620J positioners is similar except relay A is not used. The principle of operation for 3611JP and 3621JP positioners is similar except the feedback linkage does not use a cam.

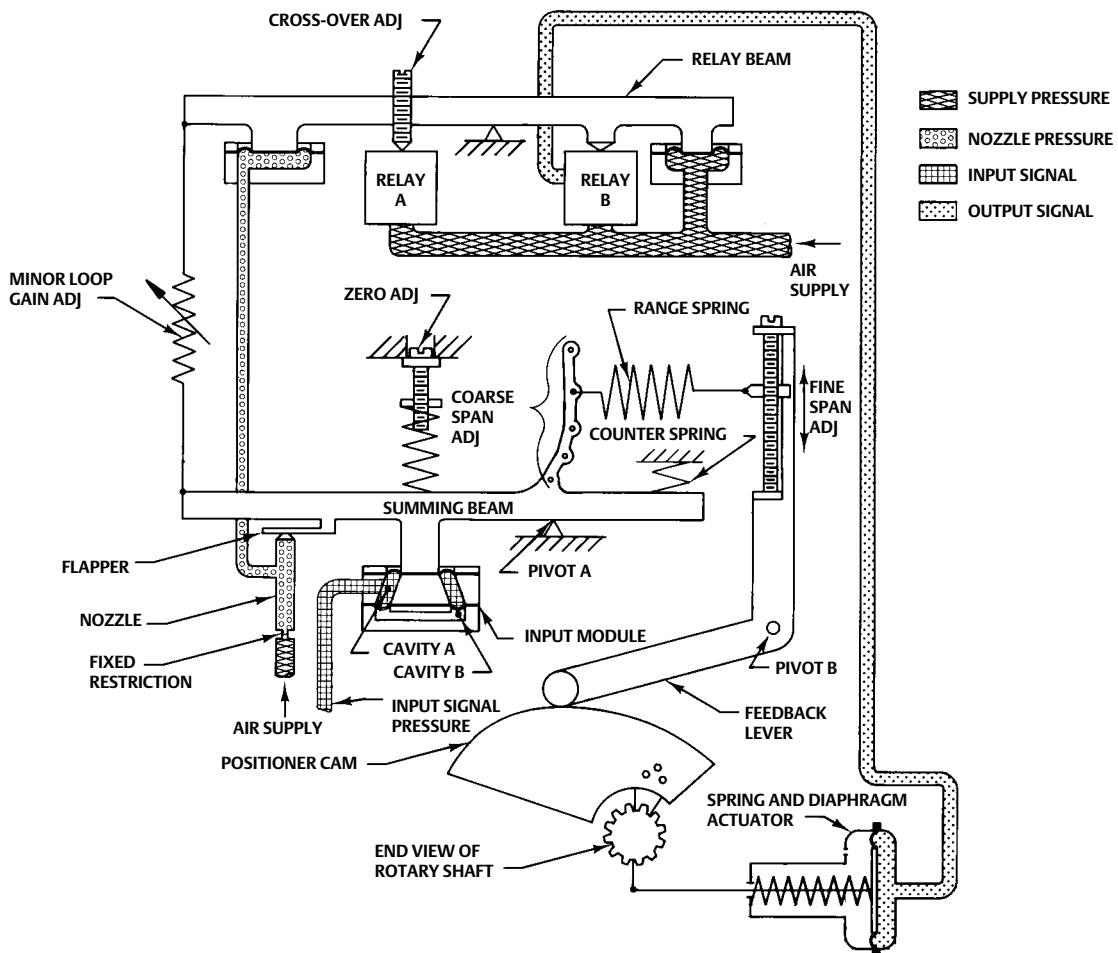
Refer to the schematic diagrams as indicated:

- 3610J—figure 20
- 3610JP—figure 21

- 3611JP—figure 22
- 3620J—figure 23
- 3620JP—figure 24
- 3621JP—figure 25

For direct action, input signal pressure from a control device is channeled to cavity A in the input module. An increase in input signal pressure results in a downward force on the summing beam, pivoting the summing beam counterclockwise. This moves the flapper slightly toward the nozzle, increasing the nozzle pressure. As nozzle pressure increases, the relay beam pivots clockwise, causing relay B to increase actuator upper cylinder pressure and relay A to exhaust actuator lower cylinder pressure to atmosphere.

Figure 20. Schematic of Fisher 3610J Positioner



38A8901-B  
B1844-1

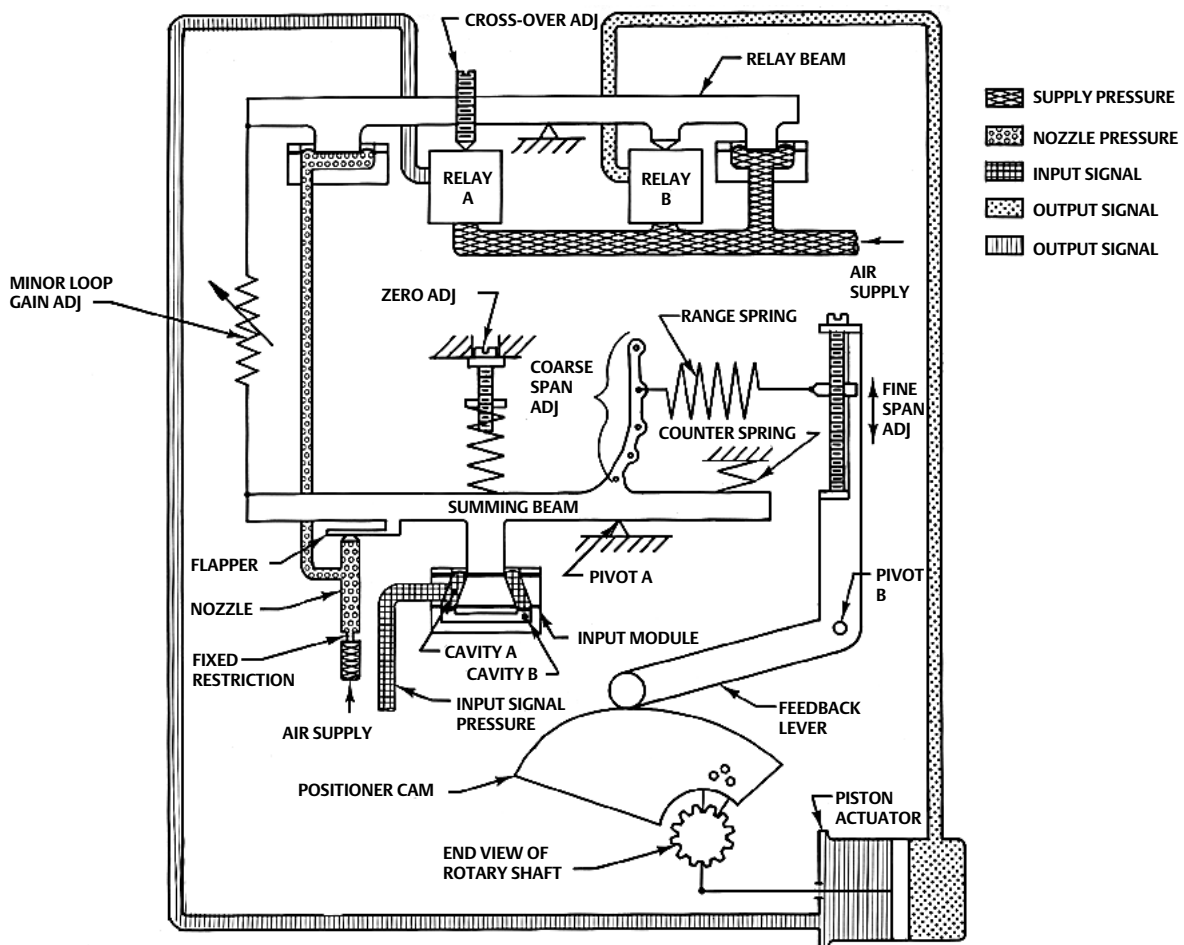
As a result, the actuator rod extends and the actuator rotary shaft rotates clockwise. This causes the feedback lever to pivot clockwise increasing the force applied to the summing beam by the range spring. This force, which opposes the downward force on the summing beam caused by the increasing input signal pressure, continues to increase until the summing beam torques are in equilibrium. At this point, the valve shaft is in the correct position for the specific input signal applied.

For reverse action, input signal pressure is channeled to both cavities A and B. An increase in input signal pressure results in an upward force on the summing beam, pivoting the summing beam clockwise and causing relay B to exhaust actuator upper cylinder pressure to atmosphere and relay A to increase actuator lower cylinder pressure. As a result, the actuator rod retracts and the actuator rotary shaft rotates counterclockwise. This causes the feedback arm to pivot counterclockwise reducing the force applied to the summing beam by the range spring.

As the valve shaft rotates counterclockwise, the range spring force on the summing beam continues to reduce until the summing beam torques are in equilibrium. At this point, the valve shaft is in the correct position for the specific input signal applied.

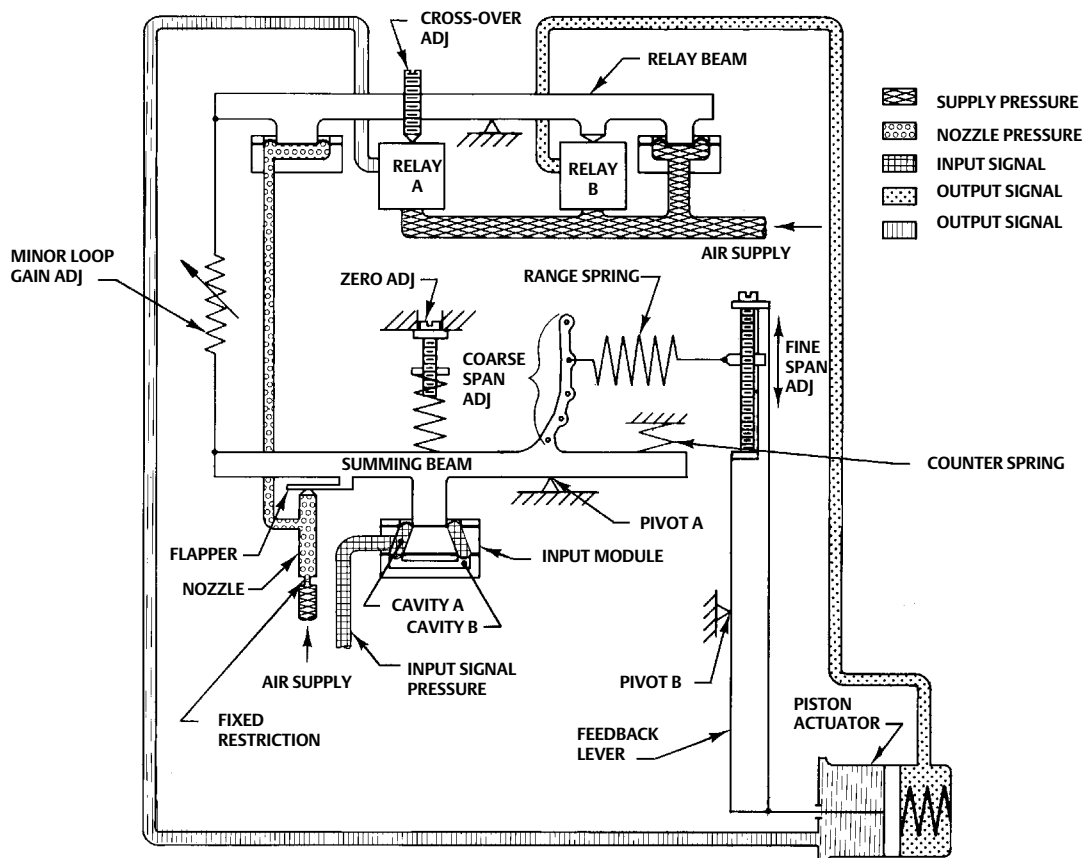
The 3620J positioner is a combination of a 3610J positioner with a 3622 electro-pneumatic converter. The electro-pneumatic converter provides a 0.2 to 1.0 bar (3 to 15 psig) output pressure proportional to the 4 to 20 milliampere DC input signal. The 0.2 to 1.0 bar (3 to 15 psig) output pressure becomes the input signal pressure to the 3610J pneumatic positioner.

Figure 21. Schematic of Fisher 3610JP Positioner



38A8900-B  
B1845-1

Figure 22. Schematic of Fisher 3611JP Positioner

36A8902-B  
B1846-1

## Maintenance

Positioner parts are subject to normal wear and must be inspected and replaced as necessary. The frequency of inspection and replacement depends upon the severity of service conditions. The following procedure describes disassembly and reassembly of the positioner. When inspection or repairs are required, disassemble only those parts necessary to accomplish the task. When reassembly is complete, make adjustments as described in the Calibration section.

### ⚠ WARNING

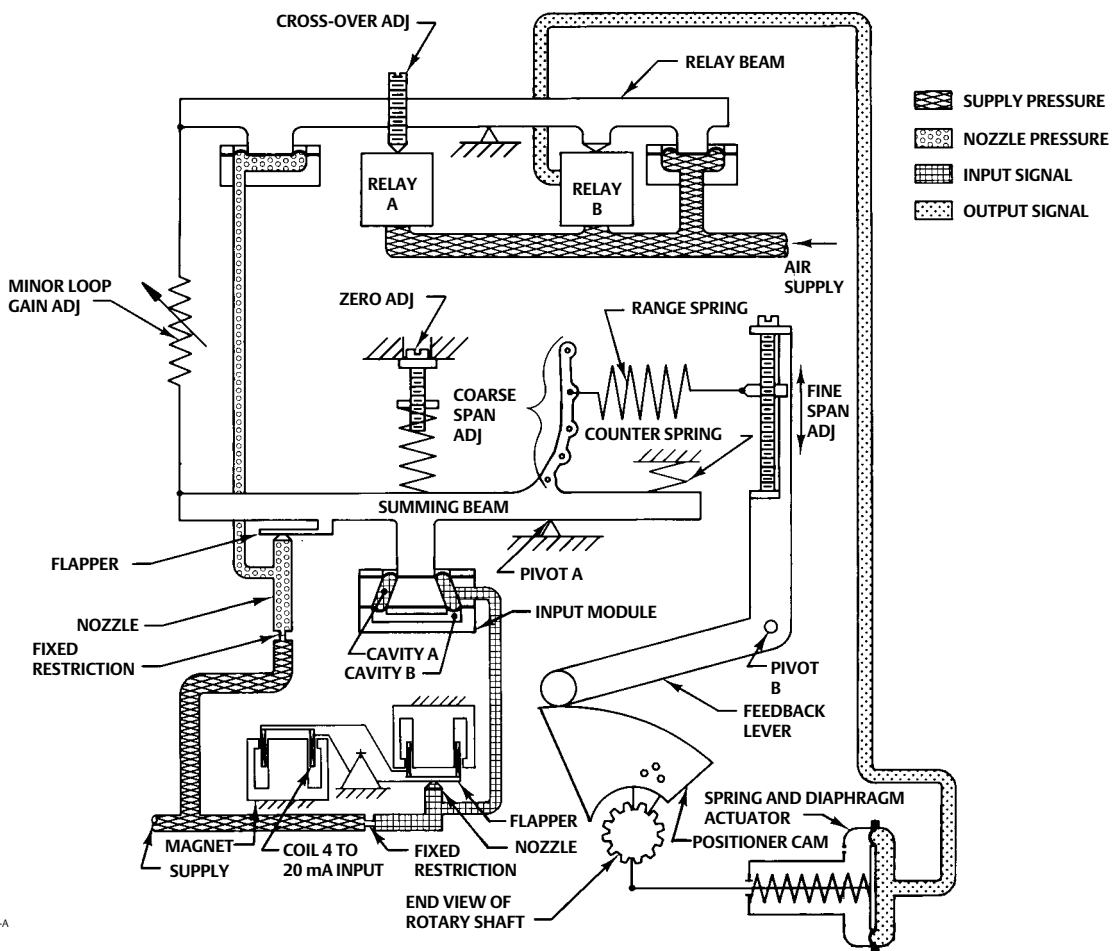
**Avoid personal injury or property damage from sudden release of process pressure. Before performing any maintenance operations:**

- Always wear protective clothing, gloves, and eyewear when performing any maintenance operations to avoid personal injury.



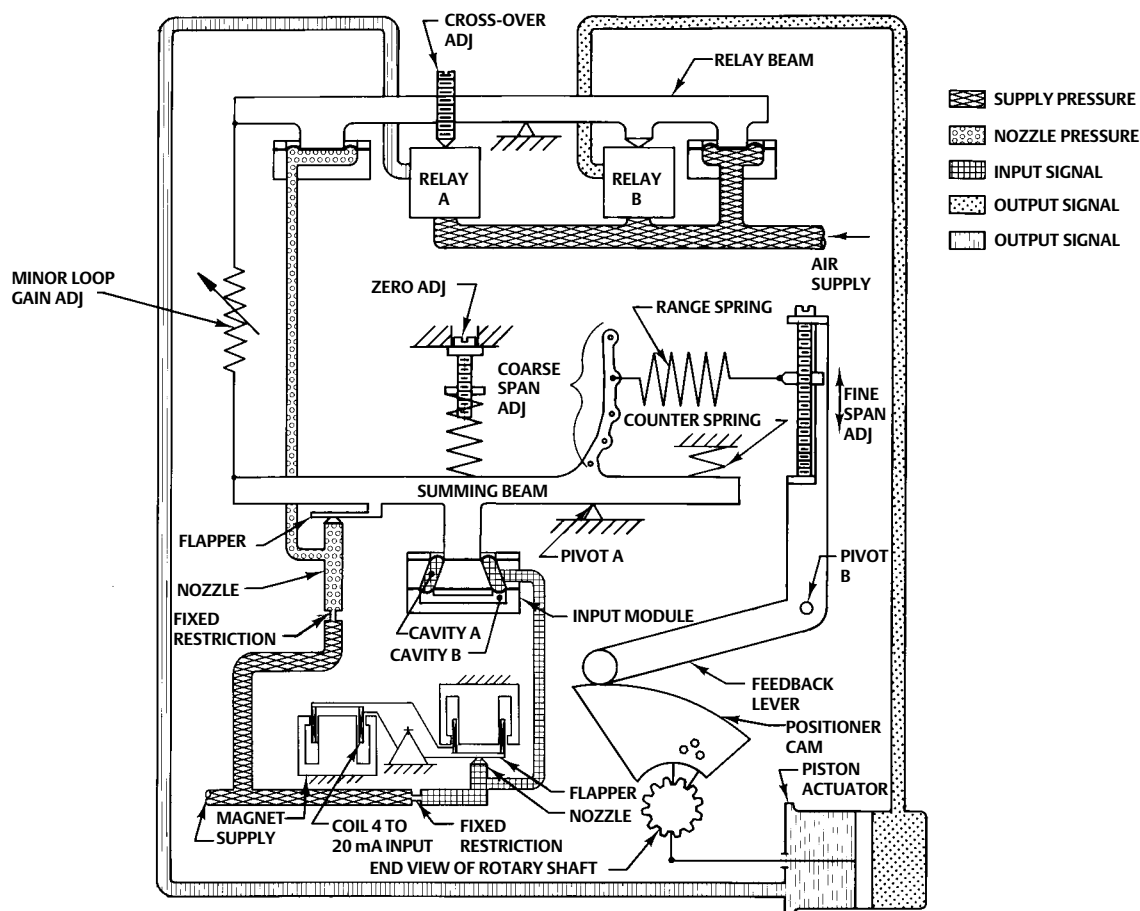
- Do not remove the actuator from the valve while the valve is still pressurized.
- Disconnect any operating lines providing air pressure, or a control signal to the actuator. Be sure the actuator cannot suddenly open or close the valve.
- When disconnecting any of the pneumatic connections, natural gas, if used as the supply medium, will seep from the unit and any connected equipment into the surrounding atmosphere. Personal injury or property damage may result from fire or explosion if appropriate preventative measures are not taken, such as adequate ventilation and the removal of any ignition sources.
- Use bypass valves or completely shut off the process to isolate the valve from process pressure.
- Vent the actuator loading pressure and disconnect positioner supply pressure.
- For explosion proof applications, disconnect power before removing the converter housing cap in an explosive atmosphere.
- Use lock-out procedures to be sure that the above measures stay in effect while you work on the equipment.
- Check with your process of safety engineer for any additional measures that must be taken to protect against process media.

Figure 23. Schematic of Fisher 3620J Positioner



38A6593-A  
B2150

Figure 24. Schematic of Fisher 3620JP Positioner

38A6594-A  
B2149

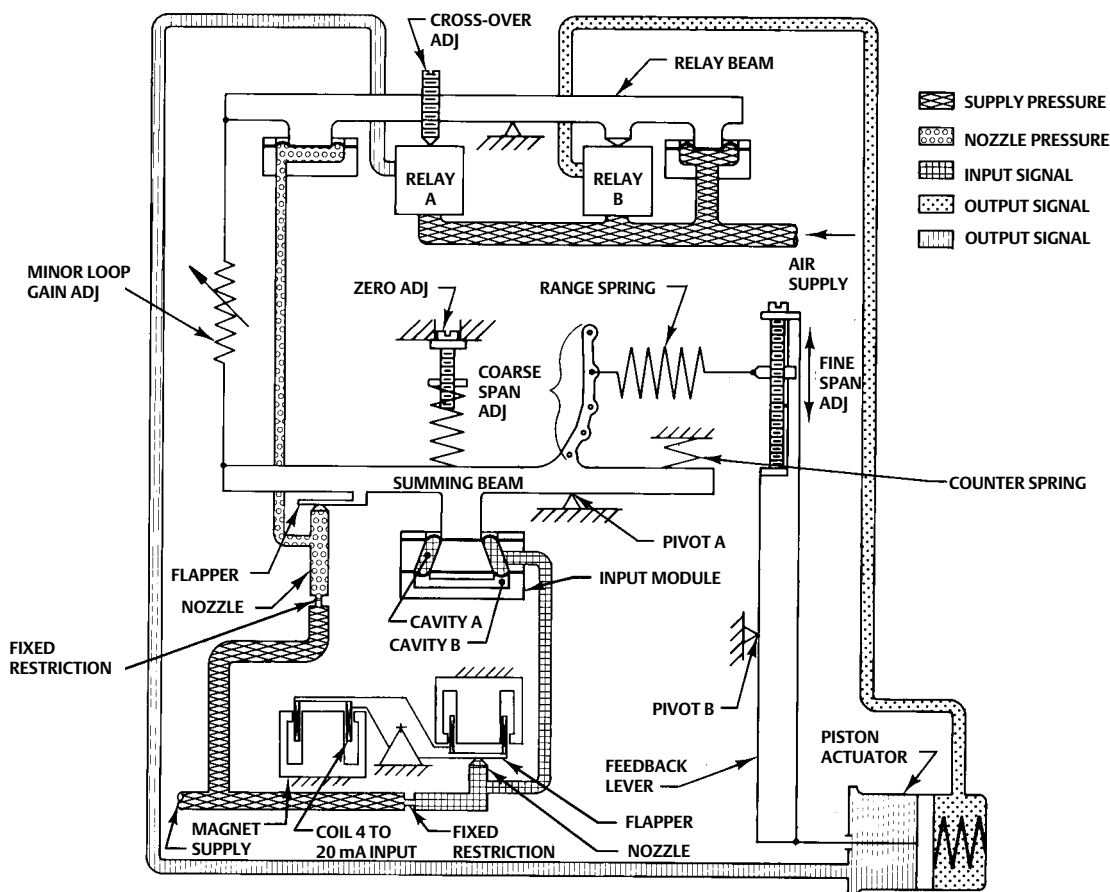
## Positioner Disassembly

### Removing the Positioner from the Actuator

Refer to figure 29 or 30 for key number locations, unless otherwise indicated, while removing the positioner from the actuator.

1. Unscrew the four socket head screws (key 54), and remove the positioner from the actuator or positioner adaptor (key 113—the positioner adaptor is used only on selected actuator types and sizes).
2. Release all pressure to the positioner. Disconnect the supply, instrument, and output tubing.  
**WARNING!** If using gas as the supply medium, ensure adequate ventilation and remove any ignition sources.
3. Unscrew the four captive cover screws and remove the cover (key 41).
4. For the 3611JP or 3621JP mounted on a 585 or 585R, size 100 with a 51 through 102 mm (2 through 4 inch) travel only, disconnect the extension spring (key 185) from the feedback lever.
5. Unscrew the four socket head screws (key 54), and remove the positioner from the actuator or positioner adaptor (key 113—the positioner adapter is used only on selected actuator types and sizes).

Figure 25. Schematic of Fisher 3621JP Positioner



38A6592-A  
B2147

## Disassembling the Bypass Valve

Refer to figure 27 for key number locations while disassembling the bypass valve.

1. Remove all pressure from the positioner. Disconnect the supply, instrument, and output tubing.  
**WARNING!** If using gas as the supply medium, ensure adequate ventilation and remove any ignition sources.
2. Remove the four socket head screws (key 169), and lift the bypass body (key 161) and bypass body gasket (key 163) from the bypass body adaptor (key 162). Inspect the gasket and replace if necessary.
3. Remove the wire tie (key 166) and the retaining ring (key 165).
4. With a gentle pulling and turning motion, slide the bypass lever assembly (key 160) from the bypass body (key 161). Inspect the O-rings (keys 159, 167, and 168) for nicks or wear and replace if necessary. Apply lubricant (key 153) to the O-rings before replacement.
5. Remove the two socket head screws (key 54) and remove the bypass body adaptor (key 162) and adaptor gasket (key 164) from the gauge block (key 158).
6. Inspect the adaptor gasket (key 164) and replace if necessary.

## Disassembling the Gauge Block

Refer to figure 27 for key number locations, unless otherwise indicated, while disassembling the gauge block.

1. If the positioner has a bypass valve, perform steps 1, 5, and 6 of the Disassembling the Bypass Valve procedures.
2. Release all pressure from the positioner. Disconnect the supply, instrument, and output tubing.  
**WARNING!** If using gas as the supply medium, ensure adequate ventilation and remove any ignition sources.
3. Remove all gauges [key 79 (not shown), 80 and 81], pipe plugs (key 72 and 78), or tire valves (key 73, not shown) from the gauge block (key 158).
4. Remove the two socket head screws (key 187) and remove the gauge block from the positioner case (key 115A, figure 26). Inspect the four O-rings (key 159) and replace if necessary. Apply lubricant (key 153) to the O-rings before replacement.

## Disassembling the 3622 Electro-Pneumatic Converter

Refer to figure 31 for key number locations while disassembling the converter.

---

### Note

To check the operation of the electro-pneumatic converter, remove the pipe plug nearest the converter (key 37, figure 31), and connect a pressure gauge. Provide a 1.4 bar (20 psig) supply pressure to the positioner. For a 4 milliamper DC input signal, the pressure gauge should read 0.17 to 0.23 bar (2.5 to 3.5 psig). For a 20 milliamper DC input signal, the pressure gauge should read 0.96 to 1.07 bar (14.0 to 15.5 psig).

---

1. Turn off electrical power to the converter. Release all supply pressure from the positioner.
2. Remove the cap (key 20), and disconnect the field wiring from the terminal block.
  - a. If a grounding wire is used inside the housing compartment, disconnect the wire from the interior housing ground screw (key 31).
  - b. If an exterior grounding wire is used, disconnect the grounding wire from the external ground screw (key 31).
3. To remove the converter module, remove the two screws (key 30) and pull the module out of the housing. Inspect the O-ring (key 26) and replace it, if necessary.
  - a. If removing the 3622 electro-pneumatic converter assembly from the pneumatic positioner, continue with steps 4 through 6. Or,
  - b. If replacing the converter module only, obtain a replacement converter module and refer to the Assembling the 3622 Electro-pneumatic Converter procedure. If replacing the converter module, calibrate the pneumatic portion of the positioner by performing the Calibration procedures after module replacement. There is no converter module calibration.
4. Disconnect the supply tubing, output tubing, and conduit from the converter.
5. If the optional 67CFR filter regulator is used, remove the two screws (key 89, figure 28), and remove the filter regulator from the converter assembly. Inspect the O-ring (key 190, figure 28) and replace if necessary. Apply lubricant (key 17) to the O-ring before replacement.
6. Remove the two socket head screws (key 35) and remove the converter from the positioner case (key 115A, figure 26). Inspect the four O-rings (key 36) and replace them if necessary. Apply lubricant (key 17) to the O-rings before replacement.

## Disassembling the Feedback Lever Assembly

Refer to figure 29 for key number locations, unless otherwise indicated, while disassembling the feedback lever assembly.

For 1051, 1052, 1061, 585, 585R, 585C, and 585CR actuators:

1. Remove the range spring (key 150, figure 26).
2. Turn the positioner over and unscrew the four machine screws (key 43) and remove the feedback lever assembly (key 117 or 170) from the positioner.
3. Remove the range spring hanger (key 130, figure 26) and the span adjustment screw (key 128, figure 26) from the feedback lever assembly (key 117 or 170) by removing the retaining ring (key 129, figure 26) and threading the span adjustment screw out of the spring hanger.
4. Remove the E-ring (key 61) and separate the pillow blocks (key 35), the spring (key 70), the spacer (key 149) and the mandrel (key 148) from the feedback lever assembly. For 3610J, 3610JP, 3620J, and 3620JP positioners only, unscrew the hex nut (key 60) and remove the follower post (key 38) and roller (key 39).
5. Press out the two flange bearings (key 37) from the pillow blocks (key 35). Inspect them for wear and replace if necessary.

## Disassembling the Reversing Plate and Gasket

Refer to figure 26 for key number locations. Remove the reversing plate screw (key 49), the reversing plate (key 23), and the gasket (key 24). Inspect the gasket, and replace if necessary.

---

### Note

When installing the gasket (key 24), ensure it is not reversed. Install the gasket so the slot in the case assembly (key 115A) aligns with one of the three holes in the gasket (key 24).

---

## Disassembling the Relay

During the following relay disassembly procedures, refer to figure 26 for key number locations.

1. Loosen the socket head screw (key 55) and remove the flexure adjustment (key 156) by carefully sliding it off the end of the two flexures (on earlier positioners, a stick-on label will have to be removed from the top flexure prior to removing the flexure adjustment). For 3611JP or 3621JP positioners only, remove the two socket head screws and lock washers (keys 180 and 181) and the parallel flexure (key 179) (not used on positioners for 585 size 100 actuators).
2. Unscrew the 12 machine screws (key 47) and lift the relay manifold (key 9) and relay beam assembly (key 122) from the positioner.
3. Remove the relay nozzle diaphragm assembly (key 8) and relay supply diaphragm assembly (key 7). Inspect them for wear and replace if necessary.
4. Unscrew the two screws (key 50) that hold the nozzle relay head (key 14) and the supply relay head (key 15), and separate them from the relay beam assembly (key 122).
5. Loosen the two set screws (key 57) in the relay manifold (key 9) and remove the pivot pin (key 10) and relay beam assembly (key 122) from the relay manifold.
6. Turn the positioner over and remove the two body plugs (key 115E) and body plug gaskets (key 115F). The valve plug springs (key 115H), valve plug shrouds (key 115K), and valve plugs (key 115G) are now exposed and can also be removed. Inspect the valve plugs for wear and replace if necessary. Inspect the body plug gaskets (key 115F) and replace if necessary.
7. Unscrew the 10 machine screws (key 115J), and remove the pressure plate (key 115C) and gasket (key 115D). Inspect the pressure plate gasket and replace if necessary.

## Disassembling the Summing Beam Assembly

During the following summing beam disassembly procedures, refer to figure 26 for key number locations.

1. Loosen the socket head screw (key 55) and remove the flexure adjustment (key 156) by carefully sliding it off the end of the two flexures (on earlier positioners, a stick-on label will have to be removed from the top flexure prior to removing the flexure adjustment). For 3611JP or 3621JP positioners only, remove the two socket head screws and lock washers (keys 180 and 181) and the parallel flexure (key 179) (not used on positioners for 585 size 100 actuators).

---

**Note**

Early 3611JP positioners do not have the parallel flexure described in step 1. The parallel flexure should be added if absent. This may require a new summing beam assembly (key 123) and relay beam assembly (key 122) if these parts are not drilled and tapped to accept the parallel flexure. See figure 26 for the location of the parallel flexure mounting screws.

---

2. Remove the range spring (key 150).
3. Relieve the tension on the zero spring (key 141) by rotating the zero adjustment screw (key 143) fully clockwise. Remove the two screws (key 139) which retain the zero spring bracket (key 144). Remove the zero spring bracket, the zero adjustment screw, and the spring seat (key 142). Remove the spring seat from the zero adjustment screw by rotating the screw counterclockwise.
4. Unscrew the counter spring screw (key 127), and remove the counter spring seat (key 126) and the counter spring (key 125).

**NOTICE**

**Rotation of the diaphragm connector will damage the input diaphragms.**

---

5. Remove the machine screw (key 140) while holding the hex diaphragm connector (key 135) with an open end wrench to prevent rotation.
6. Remove the two summing beam mounting screws (key 124). Lift the summing beam assembly (key 123) from the positioner case.
7. Remove the flapper (key 18) from the summing beam assembly by removing the flapper screw and washer (keys 51 and 176).

## Disassembling the Nozzle Assembly

During the following nozzle assembly disassembly procedures, refer to figure 26 for key number locations.

1. Perform steps 1 through 5 of the Disassembling the Summing Beam Assembly procedure.
2. Unscrew the two captive machine screws (key 45) in the nozzle block (key 146) and remove the nozzle block. Inspect the two O-rings (key 64) and replace them if necessary. Apply lubricant (key 153) to the O-rings before replacement.

**NOTICE**

**To avoid damage to the nozzle during the next step, be careful not to apply force to the exposed nozzle primary orifice. Excess force may loosen or crack the orifice.**

---

3. Remove the nozzle (key 116) from the nozzle block (key 146) by carefully pushing on the nozzle tip with the thumb or other soft object until the base of the nozzle begins to protrude from the back of the nozzle block. Grasp the base

of the nozzle and pull the nozzle from the nozzle block. Inspect the O-rings (keys 120 and 121) and replace them if necessary. Apply lubricant (key 153) to the O-rings before replacement.

4. Remove the core and wire assembly (key 147) from the nozzle block (key 146) by unscrewing the core from the nozzle block.

## Disassembling the Input Module

During the following input module disassembly procedures, refer to figure 26 for key number locations.

1. Perform steps 1 through 5 of the Disassembling the Summing Beam Assembly procedure.
2. Unscrew the remaining two input module machine screws (key 177) and remove the input diaphragm flange (key 138).
3. Remove the following as an assembly: the lower and upper diaphragms (keys 118 and 119), the lower and upper diaphragm plates (keys 132 and 134), the diaphragm spacer (key 133), the diaphragm connector (key 135), the diaphragm spacer (key 137), and the sealing screw (key 136). To disassemble this sub-assembly, unscrew the sealing screw (key 136) from the diaphragm connector (key 135) and separate the parts. Inspect the diaphragms and sealing screw O-ring and replace if necessary [earlier positioners use a standard machine screw instead of a sealing screw; replace the old standard screw with a sealing screw (key 136)].

## Positioner Reassembly

### Assembling the Input Module

Refer to figure 26 for key number locations while assembling the input module.

1. Orient the input module sub-assembly parts as shown in figure 26 and tighten the sealing screw (key 136) into the diaphragm connector (key 135).

### **NOTICE**

**Failure to use lubricant in the next step may cause damage to the sealing ribs during assembly and subsequent leakage.**

2. Apply a light lubricant silicone spray to the sealing ribs on the lower and upper input diaphragms (keys 118 and 119). See figure 26 for location.
3. Place the input module sub-assembly into the positioner case (key 115A) and align the four lower diaphragm (key 118) screw holes with the four screw holes in the positioner case. Ensure that the hole in the lobe of the lower diaphragm is aligned with the instrument air passageway in the positioner case.
4. Install the two input module machine screws (key 177) in the two holes not used to mount the zero spring bracket (key 144) and tighten. These are the two shorter screws of the four which mount the input module.
5. If the nozzle assembly was previously removed, perform the Assembling the Nozzle Assembly procedure.
6. Perform the Assembling the Summing Beam Assembly procedure and then, continue with steps 7 through 9 below.
7. If the reversing plate (key 23) was previously removed, install the gasket (key 24) and reversing plate, and reversing plate screw (key 49). When installing the gasket, make sure one of the three gasket holes is over the exhaust slot in the positioner case (key 115A). Adjust the reversing plate so the letter R is showing and the letter D is entirely covered. Tighten the screw (key 49).
8. Connect an air line to the positioner instrument connection and apply 2.4 bar (35 psig). Check the input module sealing surfaces for air leaks using a soap solution or other suitable solution compatible with nitrile rubber.
9. If reverse action is required, leave the reversing plate (key 23) as it is. If direct action is required, loosen the machine screw (key 49) and rotate the reversing plate so the letter D is showing and the letter R is entirely covered. Tighten the screw (key 49).

## Assembling the Nozzle Assembly

Refer to figure 26 for key number locations while assembling the nozzle assembly.

1. Thread the core and wire assembly (key 147) back into the nozzle block (key 146) if previously removed.
2. Apply a very light coat of lubricant (key 153) to the nozzle O-rings (keys 120 and 121). The lubricant must be applied very sparingly to avoid accidental plugging of the nozzle primary orifice.
3. Assemble the nozzle (key 116) into the nozzle block (key 146) with a gentle pushing and twisting motion to avoid nicking the O-rings. To fully seat the nozzle, align the flat at the nozzle base with the flat cast into the underside of the nozzle block.
4. Apply a very sparing amount of lubricant (key 153) to the two O-rings (key 64) and install them into the positioner case (key 115A).
5. Place the nozzle block (key 146) on the positioner case and tighten the two captive nozzle block mounting screws (key 45).
6. Perform the Assembling the Summing Beam Assembly procedure.

## Assembling the Summing Beam Assembly

Refer to figure 26 for key number locations while assembling the summing beam.

1. Install the flapper (key 18) into the summing beam assembly (key 123) with the flapper screw and washer (keys 51 and 176) so that the letter A is visible as shown in figure 26.
2. If the nozzle (key 116) has been removed, perform the Assembling the Nozzle Assembly procedure.
3. If the relay beam assembly (key 122) is removed, perform steps 1 through 7 of the Assembling the Relay Beam Assembly procedure.
4. Place the summing beam assembly (key 123) in the positioner case (key 115A) and ensure the summing beam assembly flexure is under the relay beam (key 122) flexure.
5. Loosely install the two summing beam mounting screws (key 124).
6. The summing beam assembly (key 123) must simultaneously align with the relay beam assembly (key 122) and diaphragm connector (key 135) as follows:
  - a. Depress the summing beam assembly (key 123) until the flapper lightly touches the nozzle, then slide the summing beam assembly such that the hole for the machine screw (key 140) is centered over the tapped hole in the diaphragm connector (key 135).
  - b. While keeping the above hole centered, slide the summing beam assembly such that the summing beam assembly flexure is aligned with the relay beam assembly flexure along its entire length.
  - c. While maintaining the above orientations, tighten the two mounting screws (key 124).
  - d. After tightening the mounting screws check the alignments described in steps a and b and repeat if necessary.

For optimum positioner performance, be sure the summing beam assembly is aligned as described.

7. While holding the hex diaphragm connector (key 135) with an open end wrench to prevent rotation (rotation of the diaphragm connector may damage the input diaphragms or twist them and reduce positioner performance), install the machine screw (key 140).
8. Install the counter spring (key 125), counter spring seat (key 126), and counter spring screw (127) and tighten. Ensure that the counter spring seat does not rub against the summing beam assembly (key 123) as the summing beam assembly pivots.
9. If the zero adjustment spring seat (key 142), zero spring bracket (key 144), and zero adjustment screw (key 143) were previously disassembled, place a light amount of lubricant (key 153) on the zero adjustment screw threads for



smooth zero adjustment, insert the zero adjustment screw through the zero spring bracket, and thread the zero adjustment spring seat onto the zero adjustment screw.

10. Place the zero spring (key 141) and zero spring bracket (key 144) on the positioner input module and ensure that the zero spring ends are centered on the seats. Ensure that the tab on the zero adjustment spring seat (key 142) is inserted in the anti-rotator slot in the zero spring bracket. Insert the two machine screws (key 139) through the zero spring bracket, carefully compress the zero spring by pushing down on the zero spring bracket, and tighten the screws in the positioner case.
11. If the feedback lever assembly (key 117 or 170, figure 29) was previously removed, perform the Assembling the Feedback Lever Assembly procedure; then, continue with steps 13 through 15 below.
12. Install the range spring (key 150). Refer to tables 4 through 7 and figure 16 for the correct summing beam hole number.
13. Assemble the flexure adjustment (key 156) onto the two minor loop feedback flexures. Slide the flexure adjustment along the entire length of the flexures, making sure it does not rub against the relay at any point. If contact is made with the relay or diaphragm edges at any point, remove the flexure adjustment, loosen the twelve machine screws (key 47), slide the relay manifold slightly to provide clearance and tighten the machine screws (key 47). Perform steps 2 through 5 of the Disassembling the Summing Beam Assembly procedure and loosen the two machine screws (key 124). Perform steps 4 through 10 of the Assembling the Summing Beam Assembly procedure. Assemble the flexure adjustment on the minor loop feedback flexures and check for clearance.
14. Slide the flexure adjustment (key 156) to the proper X dimension per figure 15 and tighten the socket head screw (key 55). For 3611JP and 3621JP positioners only, install the parallel flexure (key 179) with the two socket head screws and lock washers (keys 180 and 181). The parallel flexure is not used on positioners with 585 size 100 actuators.

## Assembling the Relay

Refer to figure 26 for key number locations while assembling the relay.

1. Replace the pressure plate gasket (key 115D) and pressure plate (key 115C) with the ten machine screws (key 115J). Visually align the two large holes in the pressure plate with the two stainless steel pressed-in valve seats in the positioner case (key 115A) and tighten the machine screws.
2. Install the valve plugs (key 115G), valve plug springs (key 115H), and valve plug shrouds (key 115K) in the two relay holes. Place the body plug gaskets (key 115F) on the body plugs (key 115E) and tighten in the positioner case.
3. If the pivot pin (key 10) was removed from the relay manifold (key 9), apply a light coat of lubricant (key 153) to the pin and slide it into the relay manifold and relay beam assembly (key 122). Position the pivot pin so it is flush with the left side of the relay manifold as viewed in figure 14, and tighten the two set screws (key 57). The pivot pin must not rub against the flexure adjustment (key 156).
4. Assemble the supply relay head (key 15) and nozzle relay head (key 14) onto the relay beam assembly (key 122) with the two machine screws (key 50), but do not tighten the screws. The nozzle relay head is the larger in diameter of the two and is installed in the large manifold hole. Insert the nozzle relay head holder from the repair kit through the larger manifold hole and into the nozzle relay head (key 14). Insert the supply relay head holder from the repair kit through the smaller manifold hole and into the supply relay head (key 15). Tighten the two machine screws (key 50). Remove the nozzle relay head holder and supply relay head holder from the manifold. The nozzle relay head (key 14) and supply relay head (key 15) are now correctly aligned in the center of the manifold holes.
5. Dimple the relay nozzle diaphragm (key 8) and relay supply diaphragm (key 7). Place both diaphragms in the positioner case (key 115A) with the fabric side of the diaphragms showing and align the diaphragm holes with the mounting holes in the positioner case.
6. Carefully place the relay manifold/beam assembly over the relay diaphragms. Ensure the relay diaphragms are lying flat and the diaphragm edges are not doubled over. Ensure that the diaphragm convolutions are centered in the relay manifold holes and are not pinched. The relay beam assembly (key 122) flexure must be on top of the summing beam assembly (key 123) flexure as shown in figure 15).
7. Install the twelve relay manifold machine screws (key 47), but do not tighten them.
8. If the summing beam assembly (key 123) is removed, perform the Assembling the Summing Beam Assembly procedure, steps 1 through 12. Then, continue with steps 9 through 11 below.

9. Slide the relay manifold (key 9) slightly if necessary, to visually align the relay beam assembly (key 122) flexure with the summing beam assembly (key 123) flexure along their entire length. Tighten the twelve machine screws (key 47).
10. Assemble the flexure adjustment (key 156) onto the two minor loop feedback flexures. Slide the flexure adjustment along the entire length of the flexures making sure it does not rub against the relay at any point. If contact is made with the relay or diaphragm edges at any point, remove the flexure adjustment, loosen the twelve machine screws (key 47), slide the relay manifold slightly to provide clearance and tighten the machine screws (key 47). Perform steps 2 through 5 of the Disassembling the Summing Beam Assembly procedure and loosen the two machine screws (key 124). Perform steps 4 through 10 of the Assembling the Summing Beam Assembly procedure. Assemble the flexure adjustment on the minor loop feedback flexures and check for clearance.
11. Check the supply relay head (key 15) and nozzle relay head (key 14) to ensure they are centered in the diaphragms. If not, loosen the connecting screws (key 50) and center.
12. Slide the flexure adjustment (key 156) to the proper X dimension per figure 15 and tighten the socket head screw (key 55). For 3611JP and 3621JP positioners only, install the parallel flexure (key 179) with the two socket head screws and lock washers (keys 180 and 181). The parallel flexure is not used on positioners with 585 size 100 actuators.

## Assembling the Reversing Plate and Gasket

Refer to figure 26 for key number locations while assembling the reversing plate and gasket.

Install the reversing plate gasket (key 24) and reversing plate (key 23) with the reversing plate screw (key 49). When installing the gasket, make sure one of the three gasket holes is over the exhaust slot in the positioner case (key 115A). If direct action is required, adjust the reversing plate so the letter D is showing and the letter R is entirely covered. If reverse action is required, adjust the reversing plate so the letter R is showing and the letter D is entirely covered. Tighten the screw (key 49).

## Assembling the Gauge Block

Refer to figure 27 for key number locations, unless otherwise indicated, while assembling the gauge block.

1. Apply lubricant (key 153) to the four O-rings (key 159) and install in the positioner case (key 115A, figure 26). Attach the gauge block (key 158) with the two socket head screws (key 187). During assembly of the gauge block, ensure that the O-rings stay in place to avoid leaks.
2. Assemble gauges [keys 79 (not shown), 80, and 81], pipe plugs (keys 72 and 78), or tire valves (key 73, not shown) as applicable to the gauge block (key 158). Apply sealant (key 154) to the threads of the gauges, pipe plugs, or tire valves.
3. If other positioner components are removed, refer to the appropriate reassembly procedures and assemble the positioner completely.
4. Plug the relay A and relay B output connections and apply 2.0 bar (30 psig) to the instrument connection and 2.4 bar (35 psig) minimum supply pressure to the supply connection.
5. Using soap solution or some other solution compatible with Nitrile rubber, check the gauge block O-rings and any other O-rings, gaskets, or diaphragms which were disassembled for leaks.

## Assembling the 3622 Electro-Pneumatic Converter

Refer to figure 31 for key number locations, unless otherwise indicated, while assembling the converter.

1. If the 3622 electro-pneumatic converter was removed from the pneumatic positioner, apply lubricant (key 17) to the four O-rings (key 36), and install the O-rings in the case (key 115A, figure 26). Ensure that the O-rings remain in place. Attach the converter assembly to the case with the two socket head screws (key 35) and tighten the socket head screws.

2. Install gauges (key 43), pipe plugs (key 37), or tire valves (key 41, not shown) as applicable to the converter. Apply sealant (key 39) to the threads of the gauges, pipe plugs or tire valves.
3. If the converter module was removed from the pneumatic positioner, apply lubricant (key 17) to the O-ring (key 26) and insert the converter module into the housing.
4. Replace the two screws (key 30) and tighten them.
5. If other positioner components are removed, refer to the appropriate reassembly procedures and assemble the positioner completely.
6. Connect the supply tubing, output tubing, and conduit to the converter.
7. Connect the wiring to the terminal block by using installation procedures.
  - a. If an internal grounding wire is used inside the housing compartment, connect the wire to the housing ground screw (key 31) and replace the cap (key 20).
  - b. If an exterior grounding wire is used, connect the grounding wire to the exterior ground screw (key 31).
8. Plug relay A and relay B output connections and apply 2.4 bar (35 psig) to the supply pressure connection. Apply a 20 milliamper DC input signal to the converter.
9. Check for leaks using a soap solution or other solution compatible with nitrile; check the O-rings (key 36) and any other components which were disassembled or disconnected.
10. If the converter module was replaced, calibrate the pneumatic portion of the positioner by performing the procedures in the Calibration section. There is no converter module calibration.

## Assembling the Feedback Lever Assembly

Refer to figure 29 for key number locations while assembling the feedback lever assembly.

1. Press the two flange bearings (key 37) into the pillow blocks (key 35) if removed.
2. Assemble the mandrel (key 148), the spacer (key 149), the spring (key 70), and the pillow blocks (key 35) onto the feedback lever assembly (key 117) and install the E-ring (key 61). For 3610J, 3610JP, 3620J, and 3620JP positioners only, assemble the roller (key 39) and follower post (key 38) onto the feedback lever assembly and tighten the hex nut (key 60).
3. If the span adjustment screw (key 128, figure 26) was disassembled, lightly coat the threads with lubricant (key 153) and insert the span adjustment screw into the feedback lever assembly (key 117) and thread into the spring hanger (key 130, figure 26). Ensure the tip of the span adjustment screw is in the guide hole and install the retaining ring (key 129, figure 26).
4. Assemble the feedback lever assembly (key 117) onto the positioner case (key 115A, figure 26) by attaching the pillow blocks (key 35) with the four machine screws (key 43).
5. Turn the positioner over and install the range spring (key 150, figure 26). Refer to tables 4 through 7 and figure 16 for the correct summing beam hole number.

## Assembling the Bypass Valve Assembly

Refer to figure 27 for key number locations while assembling the bypass valve assembly.

1. If the gauge block (key 158) is removed, perform the Assembling the Gauge Block procedure.
2. Assemble the adaptor gasket (key 164) and bypass body adaptor (key 162) onto the gauge block (key 158) and tighten the two socket head screws (key 54).
3. Apply lubricant (key 153) to the O-rings (keys 159, 167, and 168) sparingly and install the O-rings on the bypass lever assembly (key 160). The two center O-rings are retained in the bypass lever assembly by applying a slight twist to the O-ring with the thumb and first finger while pushing the O-ring into place.
4. Install the bypass lever assembly (key 160) into the bypass body (key 161) with a gentle twisting and pushing motion to reduce the chance of nicking an O-ring.

5. Install the retaining ring (key 165) and the wire tie (key 166).
6. Assemble the bypass body (key 161) and the bypass body gasket (key 163) onto the bypass body adaptor (key 162) with the four socket head screws (key 169). Ensure that the holes in the gasket are aligned with the holes in the bypass body. If the gasket is installed upside down, the bypass valve will not work.
7. If the reversing plate (key 23, figure 26) is removed, install the reversing plate gasket (key 24, figure 26) and reversing plate (key 23, figure 26) with the reversing plate screw (key 49, figure 26). When installing the gasket, make sure one of the three gasket holes is over the exhaust slot in the positioner case (key 115A, figure 26). If direct action is required, adjust the reversing plate so the letter D is showing and the letter R is entirely covered. If reverse action is required, adjust the reversing plate so the letter R is showing and the letter D is entirely covered. Tighten the screw (key 49).
8. If the input module is removed, perform the Assembling the Input Module procedure.
9. Plug the relay A and relay B output connections and apply 2.4 bar (35 psig) to the Instrument connection. Using soap solution or some other solution compatible with Nitrile rubber, check the bypass assembly for leaks at the gasket and O-ring seals while rotating the bypass lever to both BYPASS and POSITIONER.

## Changing Positioner Types

### Changing a 3610J to a 3610JP Positioner, Changing a 3620J to a 3620JP Positioner, or Vice Versa:

1. The nozzle (key 116, figure 26) must be changed. 3610J, 3610JP, 3620J, and 3620JP nozzles can be identified by referring to figure 8. Refer to the Disassembling the Nozzle Assembly and Assembling the Nozzle Assembly maintenance procedures.
2. The supply and output gauges [keys 79 (not shown) and 81, figure 27] must be changed and possibly the instrument gauge (key 80, figure 27) depending on the instrument input signal. Apply sealant (key 154) to the threads of the gauges.
3. The feedback lever assembly (key 117, figure 29) may need to be changed or altered depending on actuator type and size. Refer to keys 117, 170, 171, 75, 76, 77, and 99 in the parts list. To change from key 117 to 170, or vice versa, refer to the Disassembling the Feedback Lever Assembly and Assembling the Feedback Lever Assembly maintenance procedures.
4. The cam (key 82, figure 29) may need to be changed depending on actuator type and size. If the cam is changed, two screws (key 83, figure 29) may also be required and possibly a cam adjustment indicator (key 84, figure 29). The cam adjustment indicator is only used with the characterized cams B or C. Refer to the Changing Cams procedure.
5. The range spring (key 150, figure 26) may need to be changed depending on actuator type and size. Refer to tables 4 through 7 for range spring selection and hole position on the summing beam assembly for coarse span adjustment.
6. A positioner adaptor may be required depending on actuator type and size. Refer to key 113 in the parts list. If the positioner adaptor is required, four socket head screws (key 54, figure 29) will also be required for mounting.
7. Changing from a 3610JP to a 3610J or a 3620JP to a 3620J requires a pipe plug (key 78, figure 27) to plug output A. Apply sealant (key 154) to the threads of the pipe plugs.

### Changing a 3610JP to a 3611JP Positioner, Changing a 3620JP to a 3621JP Positioner, or Vice Versa:

1. Change the feedback lever assembly (key 117 or 170, figure 29) as described in the Disassembling the Feedback Lever Assembly and Assembling the Feedback Lever Assembly maintenance procedures.
2. Changing from a 3610JP to a 3611JP or a 3620JP to a 3621JP requires the following feedback parts: keys 172, 173, 174, 175, 184 (585 size 100 actuator only), and 185 [585 size 100 actuator with 51 through 102 mm (2 through 4 inch) travels only, see figure 30].
3. Changing from a 3610JP to a 3611JP, or a 3620JP to a 3621JP requires installing a parallel flexure (key 179, figure 26). The parallel flexure is not used on positioners for 585 size 100 actuators. Earlier 3611JP positioners do not have

this part. Therefore, the summing beam assembly (key 123, figure 26) or relay beam assembly (key 122, figure 26) or both may be required if they are not drilled and tapped to accept this parallel flexure. Refer to figure 26 for the location of the required tapped holes. The following parts are required: keys 179, 180, and 181, figure 26.

4. Changing from a 3610JP to a 3611JP or a 3620JP to a 3621JP requires a positioner adaptor (key 113, figure 30). Use four socket head screws (key 54, figure 30) to mount the adaptor.
5. Changing from a 3611JP to a 3610JP or a 3621JP to a 3620JP requires the following feedback parts: keys 38, 39, and 60, figure 29.
6. Changing from a 3611JP to a 3610JP or a 3621JP to a 3620JP requires a cam (key 82, figure 29). Two screws (key 83, figure 29) mount the cam and a cam adjustment indicator (key 84, figure 29—used only with characterized cams B or C). Refer to the Mounting 3610J, 3610JP, 3620J, and 3620JP Positioners procedures for correct cam mounting.
7. Changing from a 3611JP to a 3610JP or a 3621JP to a 3620JP may require additional feedback parts depending on actuator type and size. Refer to keys 75, 76, 77, 99, and 171 in the parts list and figure 29 to determine if they are required.
8. The range spring (key 150, figure 26) may need to be changed depending on actuator type and size. Refer to tables 4 through 7 for range spring selection and hole position on the summing beam assembly for coarse span adjustment.
9. The instrument gauge (key 80, figure 27) may need to be changed depending on the input signal. Apply sealant (key 154) to the threads of the gauge.

#### Changing a 3610J to a 3611JP Positioner, Changing a 3620J to a 3621JP Positioner, or Vice Versa:

1. Change the feedback lever assembly (key 117, figure 29) by performing the Disassembling the Nozzle Assembly and Assembling the Feedback Lever Assembly maintenance procedures.
2. The nozzle (key 116, figure 26) must be changed. Refer to the parts list for the correct nozzle assembly part number. Refer to figure 8 to identify 3610J, 3620J, 3611JP, and 3621JP nozzles. Refer to the Disassembling the Nozzle Assembly and Assembling the Nozzle Assembly maintenance procedures.
3. The supply and output gauges [keys 79 (not shown) and 81, figure 27] must be changed and possibly the instrument gauge (key 80, figure 27) depending on the input signal. Apply sealant (key 154) to the threads of the gauges.
4. Changing from a 3610J to a 3611JP or a 3620JP to a 3621JP requires the following feedback parts: keys 172, 173, 174, 175, 184 (585, size 100 actuator only), and 185 [585 actuator, size 51 through 102 mm (100 with 2 through 4 inch) travels only, see figure 30].
5. Changing from a 3610J to a 3611JP or a 3620J to a 3621JP requires installing a parallel flexure (key 179, figure 26). The parallel flexure is not used on positioners for 585 size 100 actuators. Earlier 3611JP positioners do not have this part. Therefore, the summing beam assembly (key 123, figure 26) or relay assembly (key 122, figure 26) or both may be required if they are not drilled and tapped to accept this parallel flexure. The following parts are required: keys 179, 180, and 181, figure 26.
6. Changing from a 3610J to a 3611JP or a 3620JP to a 3621JP may require a positioner adaptor (key 113, figure 29). Use four socket head screws (key 54, figure 29) to mount the adaptor.
7. Changing from a 3611JP to a 3610J or a 3621JP to a 3620J requires the following feedback parts: keys 38, 39, and 60 in figure 29.
8. Changing from a 3611JP to a 3610J or a 3621JP to a 3620J, requires a cam (key 82, figure 29). Mount the cam with two screws (key 83, figure 29) and a cam adjustment indicator (key 84, used only with characterized cams B or C, figure 29). Refer to the Mounting 3610J, 3610JP, 3620J, and 3620JP Positioners procedures for correct cam mounting.
9. Changing from a 3611JP to a 3610J or a 3621JP to a 3620J requires a pipe plug (key 78, figure 27) to plug output A. Apply sealant (key 154) to the threads of the pipe plug.
10. The range spring (key 150, figure 26) may need to be changed depending on actuator type and size. Refer to tables 4 through 7 for range spring selection and hole position on the summing beam assembly for coarse span adjustment.

## Parts Ordering

When corresponding with your [Emerson sales office](#) about this equipment, always mention the positioner serial number.

### **⚠ WARNING**

**Use only genuine Fisher replacement parts. Components that are not supplied by Emerson should not, under any circumstances, be used in any Fisher instrument. Use of components not supplied by Emerson may void your warranty, might adversely affect the performance of the instrument, and could cause personal injury and property damage.**

## Parts Kits

Key	Description	Part Number
	For 3610J w/bypass (kit contains keys 7, 8, 18, 24, 64, 115D, 115F, 115G, 115H, 116, 118, 119, 120, 121, 136, 159, 163, 164, 167, 168, instructions, and supply and nozzle relay head holders)	R3610JX0012
	For 3610JP, 3611JP, 3620JP, and 3621JP positioners and 3610J (w/o bypass) and 3620J with 2052 actuator (kit contains keys 7, 8, 18, 24, 64, 115D, 115F, 115G, 115H, 116, 118, 119, 120, 121, 136, 159, instructions, and supply and nozzle relay head holders)	R3610JPX012
	For 3610J bypass valve (kit contains keys 54, 164, and bypass valve assembly)	R3610JXBP12
	For 3622 converter, the kit contains keys 22, 23, 24, 26, 27, 29, and 36. An additional O-ring is also included for the I/P converter outlet.	R3622X00012
	For 3610J and 3620J positioners on 2052 actuators. (kit contains keys 18, 45, 51, 64, 116, 120, 121, 146, 147, 176, nozzle and flapper replacement)	R3610JX0062
	3622 I/P Converter module	33B7073X032

## Parts List

### Note

Contact your [Emerson sales office](#) for Part Ordering information.

## Positioner Common Parts

Key	Description
7	Relay supply diaphragm assembly
8	Relay nozzle diaphragm assembly
9	Relay manifold
10	Pivot pin
13	Crossover screw
14	Nozzle relay head
15	Supply relay head
18*	Flapper
23	Reversing plate
24*	Reversing plate gasket
35	Pillow block (2 req'd)
37	Flange bearing (2 req'd)
38	Follower post, for 3610J, 3610JP, 3620J, and 3620JP
39	Roller, for 3610J, 3610JP, 3620J, and 3620JP
41	Cover assembly (includes cover screws)

Key	Description	Part Number	Key	Description
43	Machine screw (4 req'd)		82	Cam
45	Access cover screw (2 req'd)			w/1051, size 40 or 60
47	Machine screw (12 req'd)			w/1052, size 40, 60, or 70
49	Machine screw			w/1061, size 30 through 68
50	Machine screw (2 req'd)			Cam A (linear)
51	Machine screw			Cam B (direct acting)/Cam C (reverse acting)
54	Cap screw (number required per assembly varies; maximum req'd for any assembly is 10)			Cam C (direct acting)/Cam B (reverse acting)
				w/1052 size 20
55	Machine screw			Cam A (linear)
56	Self tapping screw (2 req'd)			Cam B (direct acting)/Cam C (reverse acting)
57	Set screw (2 req'd)			Cam C (direct acting)/Cam B (reverse acting)
60	Hex nut For 3610J, 3610JP, 3620J and 3620JP			w/1051, size 33
				w/1052, size 33
				Cam A (linear)
61	E-ring			Cam B (direct acting)/Cam C (reverse acting)
64*	O-ring (2 req'd)			Cam C (direct acting)/Cam B (reverse acting)
70	Spring			w/1061 size 80, 100, or 130
				Cam A (linear)
				Cam B (direct acting)/Cam C (reverse acting)
72	Pipe plug, 1/8 NPT (None req'd w/supply gauge option) 1 req'd for gauge option w/o supply gauge or tire valve option 4 req'd w/o gauges or tire valves, w/pipe plug option			Cam C (direct acting)/Cam B (reverse acting)
				w/1069 size 100
				Cam A (linear)
				Cam B (direct acting)/Cam C (reverse acting)
73	Tire valve, w/tire valve option (3 req'd)			Cam C (direct acting)/Cam B (reverse acting)
75	Machine screw (2 req'd) For 3610JP and 3620JP w/1061, size 80, 100, or 130			w/1069 size 100
				Cam A (linear)
				Cam B (direct acting)/Cam C (reverse acting)
				Cam C (direct acting)/Cam B (reverse acting)
76	Follower arm extension For 3610JP and 3620JP w/1061, size 80 or 100 w/1061, size 130			w/2052, size 1
				Cam A (linear)
				Cam B (direct acting)/Cam C (reverse acting)
				Cam C (direct acting)/Cam B (reverse acting)
77	Hex nut (2 req'd), For 3610JP and 3620JP w/1061, size 80, 100, or 130			w/2052, size 2 or 3
				Cam A (linear)
				Cam B (direct acting)/Cam C (reverse acting)
				Cam C (direct acting)/Cam B (reverse acting)
78	Pipe Plug, for 3610J and 3620J w/o bypass		83	Machine screw (2 req'd)
				w/1051, size 40 or 60
				w/1052, size 40, 60, or 70
				w/1061, size 30 through 68
				w/1052, size 20 or 33
				w/1051, size 33
				w/1061, size 80 100, or 130
				w/1069, size 100
				w/2052, size 1, 2, or 3
79*	Supply gauge, plastic case w/brass chrome plated conn (w/supply gauge option) Triple scale 0 to 2 bar/0 to 0.2 MPa/0 to 30 psig 0 to 4 bar/0 to 0.4 MPa/0 to 60 psig 0 to 11 bar/0 to 1.1 MPa/ 0 to 160 psig	11B4036X012 11B4036X022 11B4036X032	84	Cam adjustment indicator For 3610J, 3610JP, 3620J, and 3620JP (w/Cams B or C only, not req'd w/Cam A or w/1069, size 100) w/1051, size 33, 40 or 60 w/1052, size 20, 33, 40, 60, or 70 w/1061, size 30 through 68 w/1061, size 80, 100, or 130 w/2052, size 1 w/2052, size 2 or 3
80*	Instrument gauge, plastic case w/brass chrome plated conn Triple scale 0 to 2 bar/0 to 0.2 MPa/0 to 30 psig 0 to 4 bar/0 to 0.4 MPa/0 to 60 psig 0 to 11 bar/0 to 1.1 MPa/0 to 160 psig	11B4036X012 11B4036X022		
81*	Output gauge, plastic case w/brass chrome plated conn (2 req'd) Triple scale 0 to 2 bar/0 to 0.2 MPa/0 to 30 psig 0 to 4 bar/0 to 0.4 MPa/0 to 60 psig 0 to 11 bar/0 to 1.1 MPa/0 to 160 psig	11B4036X012 11B4036X022 11B4036X032	87	Tubing connector (specify quantity required) (not shown) 1/4 NPT x 3/8 O.D.
			88	Tubing elbow (specify quantity required) 1/4 NPT x 3/8 O.D.
			89	Cap screw (2 req'd) For mounting regulator

\* Recommended spare parts

Key	Description	Key	Description
92	Lockwasher (not shown) (specify quantity) Yoke or casing mounted filter regulator	133	Diaphragm spacer
99	Lockwasher (2 req'd) For 3610JP and 3620JP w/1061, size 80, 100, or 130	134	Upper diaphragm plate
109	Anti-Seize Compound (not furnished with the positioner)	135	Diaphragm connector
113	Positioner adaptor For 3610J and 3620J w/1051, size 33 w/1052, size 20 and 33 w/2052, size 1 For 3610JP w/ 1069 size 100 For 3611JP and 3621JP w/585, 585C, 585CR and 585R actuators	136	Sealing screw
115	Valve seat assembly (includes keys 115A, 115B, 115C, 115D, 115E, 115F, 115G, 115H, 115J, & 115K)	137	Diaphragm spacer
115A	Case assembly [includes case (key 115A) and valve seats (key 115B)]	138	Input diaphragm flange
115B	Valve seat (2 req'd)	139	Machine screw (2 req'd)
115C	Pressure plate	140	Machine screw
115D*	Pressure plate gasket	141	Zero spring
115E	Body plug (2 req'd)	142	Spring seat
115F*	Body plug gasket (2 req'd)	143	Zero adjustment screw
115G	Valve plug (2 req'd)	144	Zero spring bracket
115H	Valve plug spring (2 req'd)	146	Nozzle block
115J	Machine screw (10 req'd)	147	Core & wire assembly
115K	Shroud (2 req'd)	148	Mandrel
116*	Nozzle assembly For 3610J and 3620J except with 2052 actuator For 3610J and 3620J with 2052 actuator, and 3610JP, 3620JP, 3611JP, and 3621JP	149	Spacer
117	Feedback lever assembly For 3610J, 3610JP, 3620J, and 3620JP w/1051, all sizes except size 33 w/1052, all sizes except size 20 and 33 w/1051, size 33 w/1052, size 20 and 33 w/2052, size 1 w/2052, size 2 and 3 For 3611JP and 3621JP w/585C, size 25 and 50 See key 170 for 585, size 100 and 1069, size 100	150	Range spring color coded blue color coded red color coded yellow
118*	Lower input diaphragm	151	Warning label
119*	Upper input diaphragm	153	Lithium grease (not furnished with positioner)
120*	O-Ring	154	Anti-seize sealant (not furnished with positioner)
121*	O-Ring	155	Pipe Nipple
122	Beam assembly	156	Flexure adjustment
123	Summing beam assembly	157	Nameplate
124	Machine screw (2 req'd)	158	Gauge block, for 3610J, 3610JP, and 3611JP only
125	Counterspring	159*	O-Ring, (4 req'd w/gauge block, or 5 req'd w/gauge block and bypass valve)
126	Spring seat	160	Bypass lever assembly
127	Machine screw	161	Bypass body
128	Span adjustment screw	162	Bypass body adapter
129	Prong-lock ring	163*	Bypass body gasket
130	Range spring hange	164*	Adapter gasket
131	Instruction label	165	Retaining ring
132	Lower diaphragm plate	166	Wire tie
		167*	O-ring
		168*	O-ring (2 req'd)
		169	Machine screw (4 req'd)
		170	Feedback lever assembly For 3611JP and 3621JP w/ 585, size 100 19 to 51 mm travel (3/4 to 2-inch) 51 to 102 mm travel (2 to 4-inch) For 3610JP and 3620JP w/1069, size 100
		171	Torsion spring For 3610J and 3620JP w/1069, size 100
		172	Retaining ring For 3611JP and 3621JP
		173	Button head screw For 3611JP and 3621JP
		174	Adjuster assembly For 3611JP and 3621JP w/585C, size 25 or 50 w/585, size 100



Key	Description	Key	Description	Part Number
175	Roller, for 3611JP and 3621JP	21	Filter plug, used w/o integrally mounted 67CFR filter regulator	
176	Lockwasher	22*	Filter, 40 micrometer, used w/o integrally mounted 67CFR filter regulator	
177	Machine screw (2 req'd)	23*	O-ring	
178	Anti-seize sealant (not furnished with positioner)	24	O-ring, used w/o integrally mounted 67CFR filter regulator	
179	Parallel flexure For 3611JP and 3621JP w/585C, size 25 w/585C, size 50 None req'd for 585, size 100	25	Nozzle restriction	
180	Machine screw (2 req'd) For 3611JP and 3621JP w/ 585C, size 25 or 50 None req'd for 585 size 100	26	O-ring	
181	Lockwasher (2 req'd) For 3611JP and 3621JP w/585C, size 25 or 50 None req'd for 585, size 100	27*	O-ring	
184	Washer (2 req'd) For 3611JP or 3621JP w/585, size 100	28	Vent	
185	Extension spring For 3611JP or 3621JP w/585, size 100, w/51-102 mm (2-4 inch) travel	29*	O-ring	
187	Machine screw (2 req'd)	30	Machine screw (2 req'd)	
188	Thread Locking adhesive (medium strength), (not furnished with positioner)	31	Wire retaining screw (2 req'd)	
190	O-ring	32	Nameplate, non-approved	
191	Pipe Plug, used with integral mounted filter/regulator	33	Drive screw (2 req'd)	
193	Lubricant, silicone sealant (not furnished with positioner)	35	Cap screw (2 req'd)	
194	Mounting bracket For 3611JP and 3621JP w/585C actuator	36*	O-ring (4 req'd)	
195	Stem bracket For 3611JP and 3621JP w/585C actuator	37	Pipe plug use only when specified w/o gauges or tire valves (3 req'd) w/o gauges and w/tire valves (1 req'd)	
196	Cap screw (3 req'd) For 3611JP and 3621JP w/585C actuator	38*	Supply gauge, plastic case w/brass chrome plated conn (w/supply gauge option) Triple scale 0 to 2 bar/0 to 0.2 MPa/0 to 30 psig 0 to 4 bar/0 to 0.4 MPa/0 to 60 psig 0 to 11 bar/0 to 1.1 MPa/ 0 to 160 psig	11B4036X012 11B4036X022 11B4036X032
197	Hex Nut (6 req'd) For 3611JP and 3621JP w/585C actuator	39	Anti-seize sealant (not furnished with positioner)	
		41	Tire valve, use only when specified, (2 req'd)	
		42	Anti-seize lubricant (not furnished with positioner)	
		43*	Output gauge, plastic case w/brass chrome plated conn (2 req'd) Triple scale 0 to 2 bar/0 to 0.2 MPa/0 to 30 psig 0 to 4 bar/0 to 0.4 MPa/0 to 60 psig 0 to 11 bar/0 to 1.1 MPa/0 to 160 psig	11B4036X012 11B4036X022 11B4036X032
		48	Pipe plug, used with 3620J only	

**3622 Electro-Pneumatic Converter**

	I/P Converter module
17	Lithium grease (not furnished with positioner)
19	Housing 1/2-14 NPT conduit connection
20	Cap

## Diagnostic Connections

FlowScanner valve diagnostics system hook-up

Includes connector body and body protector. If ordered for units with gauges, a stem is also included.

### Description

For 3610J Positioners  
For units w/gauges  
For units w/o gauges

### Description

For 3610JP Positioners  
For units w/gauges  
For units w/o gauges

For 3620J Positioners  
For units w/gauges  
For units w/o gauges

For 3620JP Positioners  
For units w/gauges  
For units w/o gauges

Figure 26. Positioner Assembly

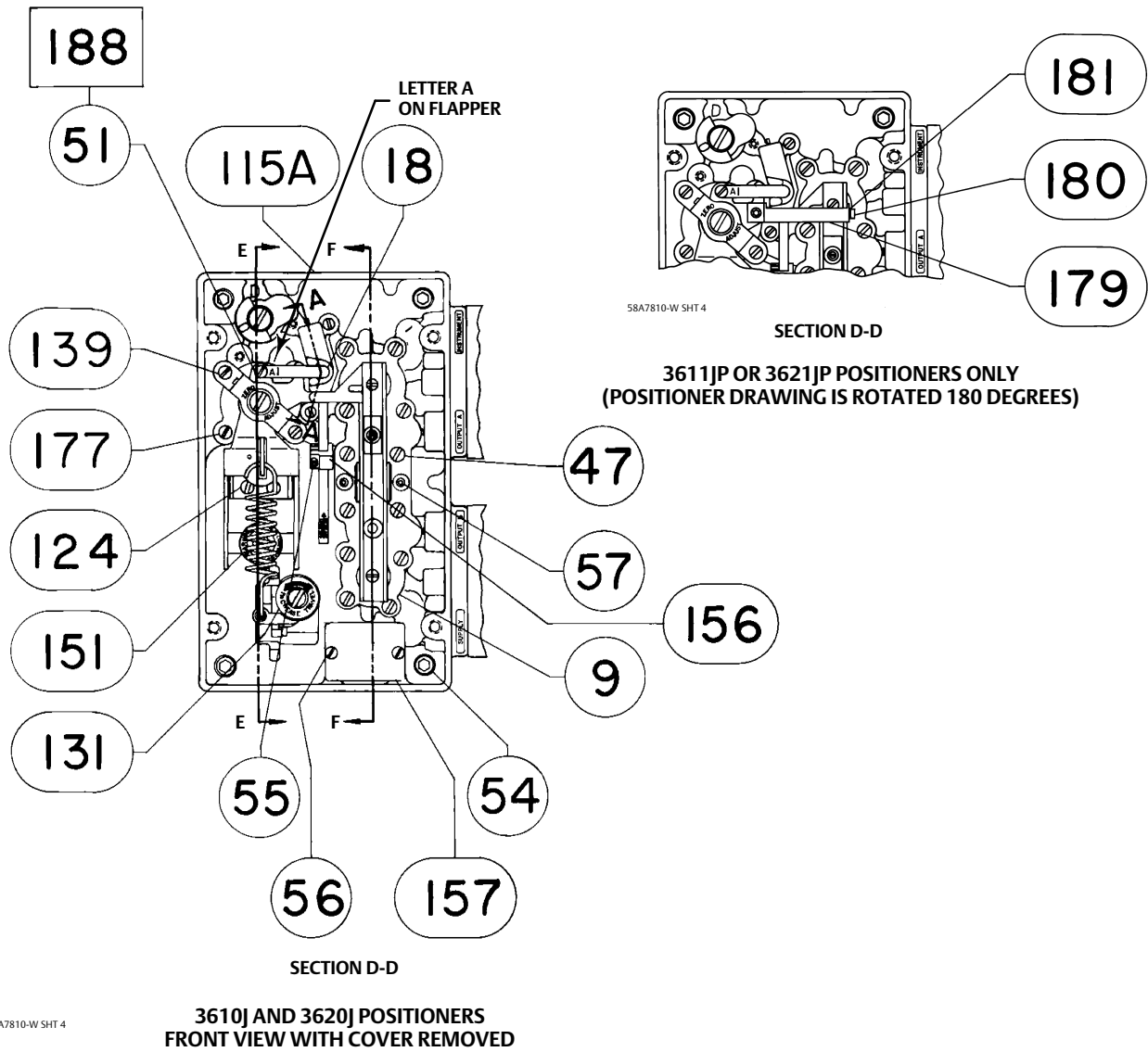
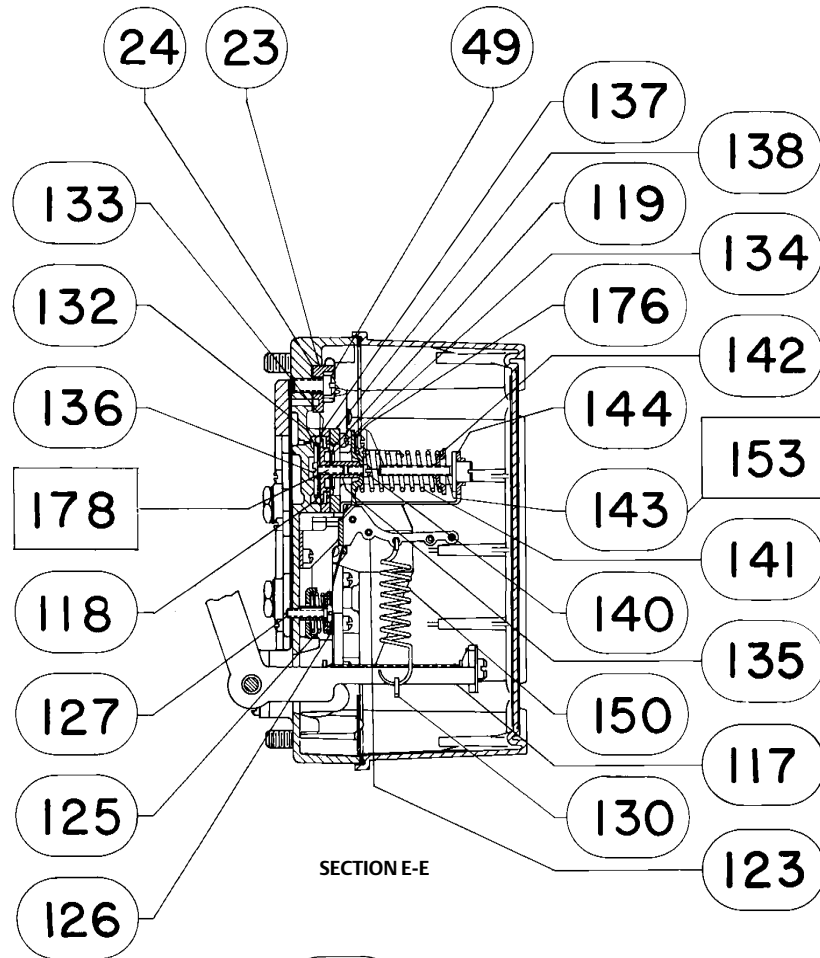
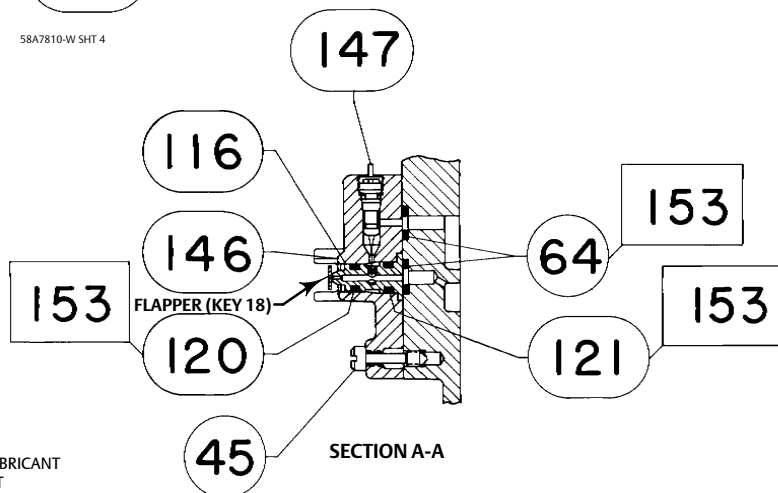


Figure 26. Positioner Assembly (continued)



58A7810-W SHT 4



□ APPLY LUBRICANT OR SEALANT

58A7810-W SHT 4

NOZZLE/FLAPPER

Figure 26. Positioner Assembly (continued)

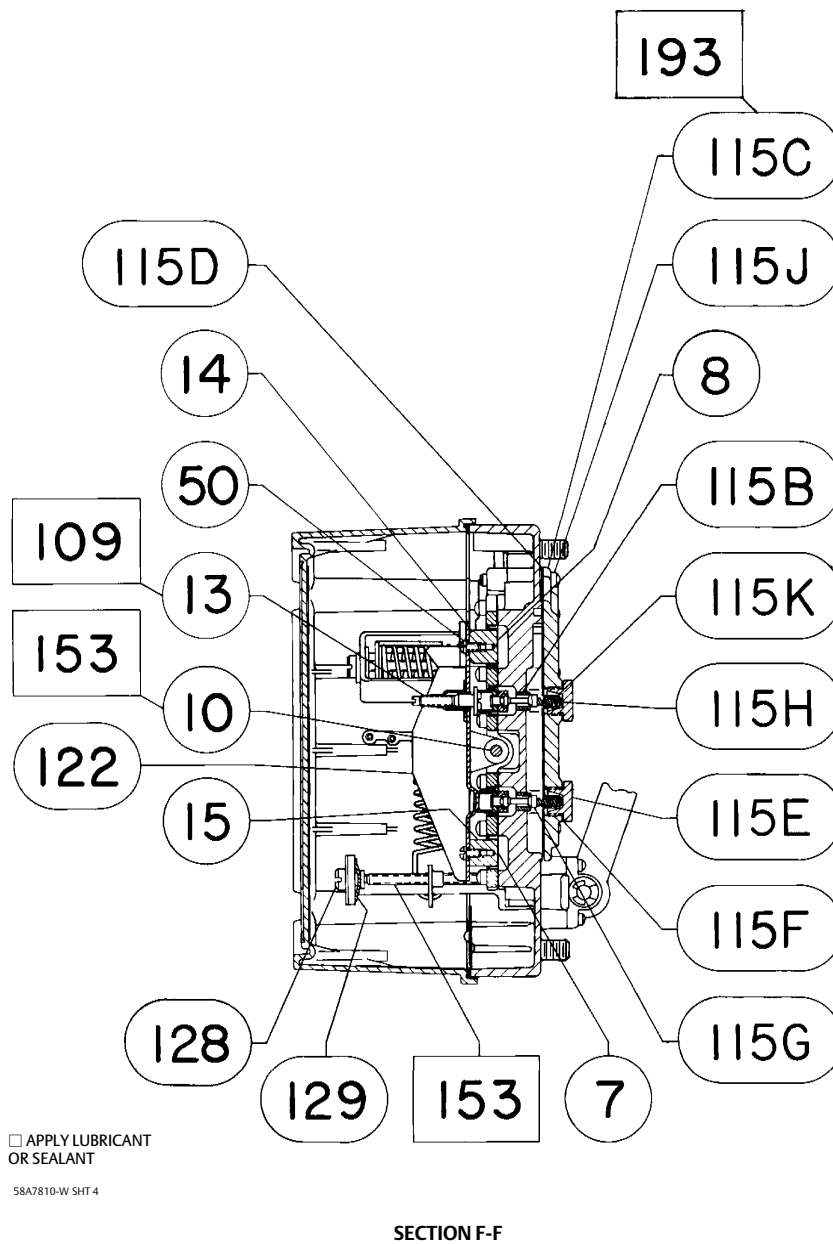
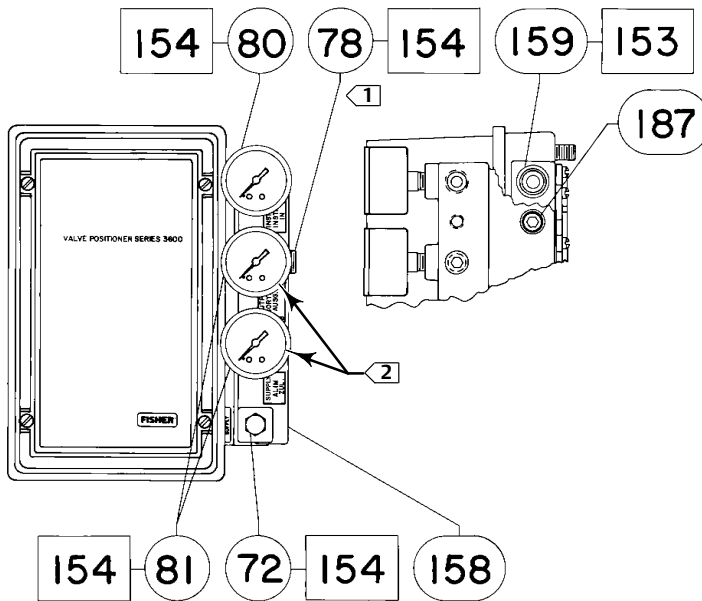
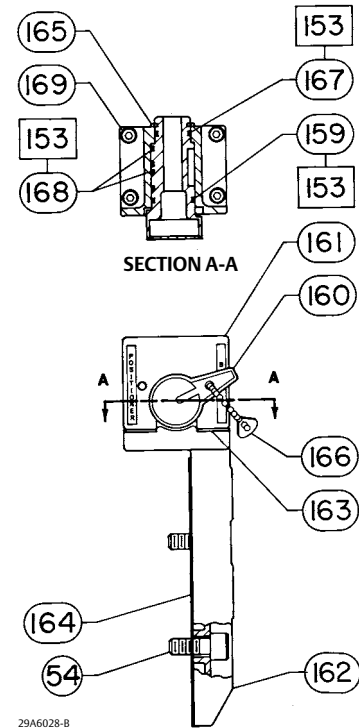


Figure 27. Gauge Block and Bypass Valve Assemblies



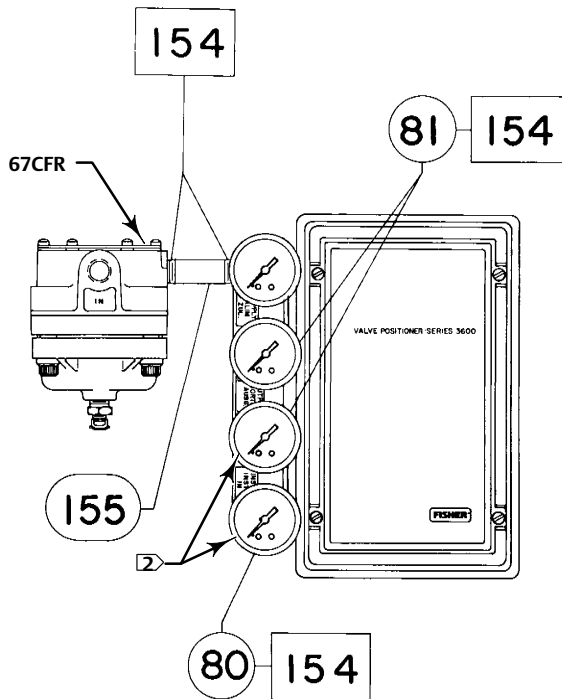
58A7810W SHT 1

3610J AND 3610JP POSITIONER



29A6028-B

BYPASS VALVE ASSEMBLY FOR 3610J POSITIONERS



58A7810-W SHT 3

3611JP POSITIONER WITH GAUGES

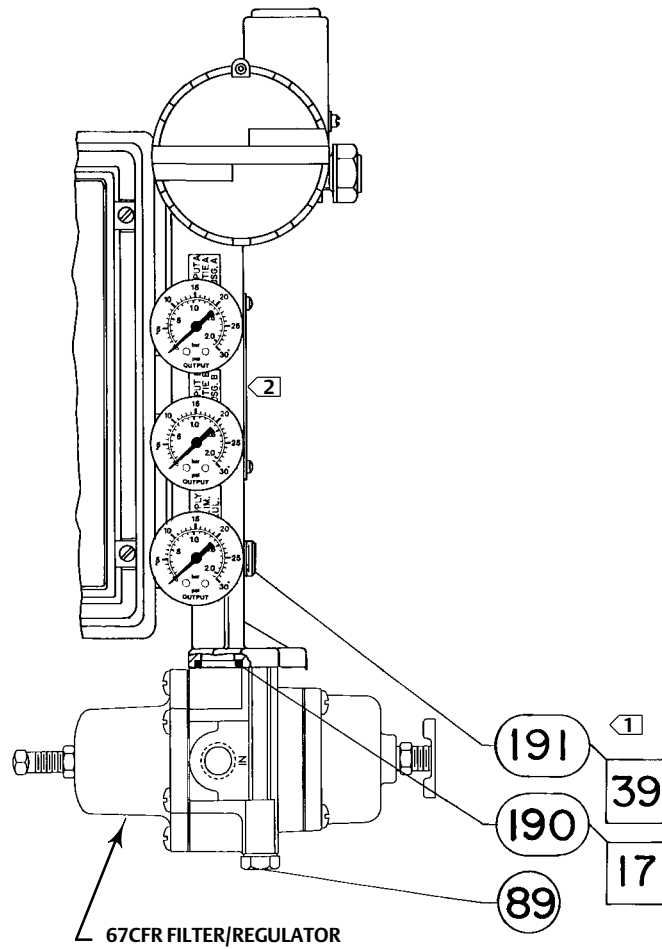
□ APPLY LUBRICANT OR SEALANT

NOTES:

1 KEY 78 IS USED FOR 3610J POSITIONER ONLY.

2 GAUGES MAY BE REPLACED BY PIPE PLUGS (KEY 72) OR TIRE VALVES (KEY 73).

Figure 28. Fisher 3620J Positioner with Integral Mounted Filter/Regulator



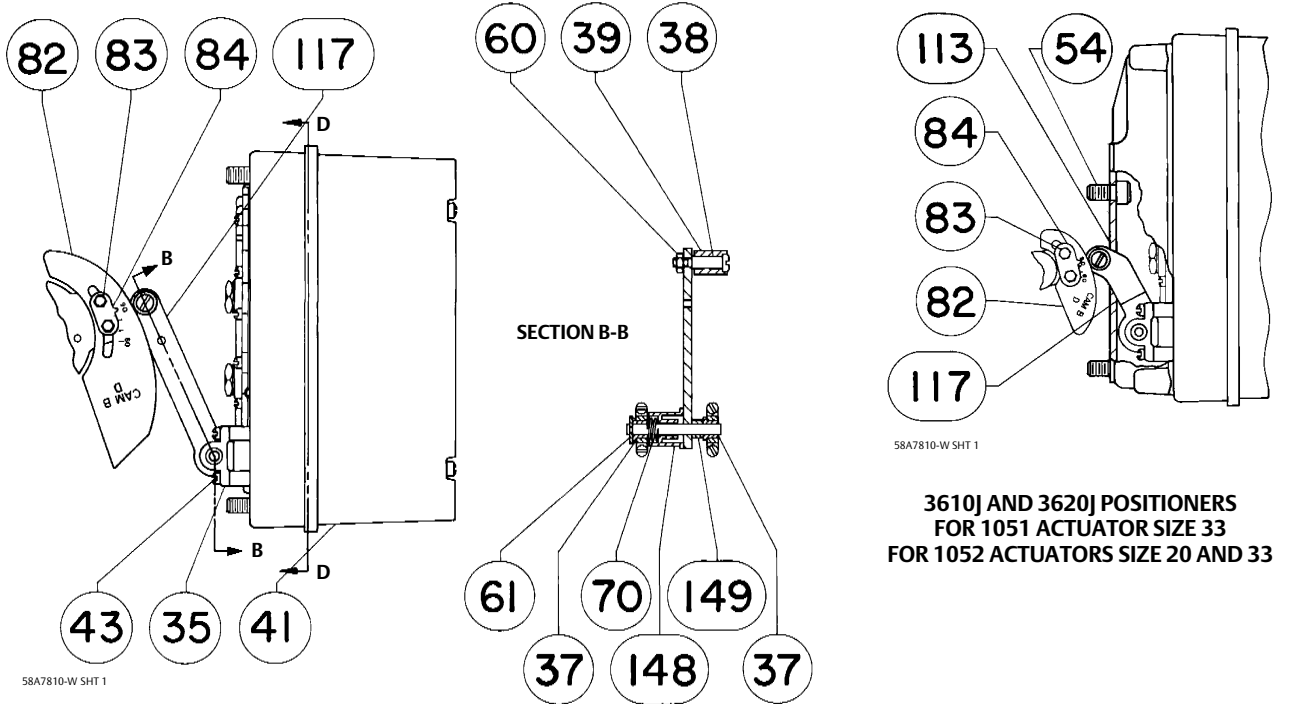
NOTES:

- 1 THIS PIPE PLUG IS USED ONLY WITH INTEGRAL MOUNTED FILTER/REGULATOR.
- 2 SEE FIGURE 31 FOR 3622 ELECTRO-PNEUMATIC CONVERTER KEY NUMBERS.

41B2337-K SHT 1

**3620J POSITIONERS WITH GAUGES AND  
INTEGRAL MOUNTED FILTER/REGULATOR**

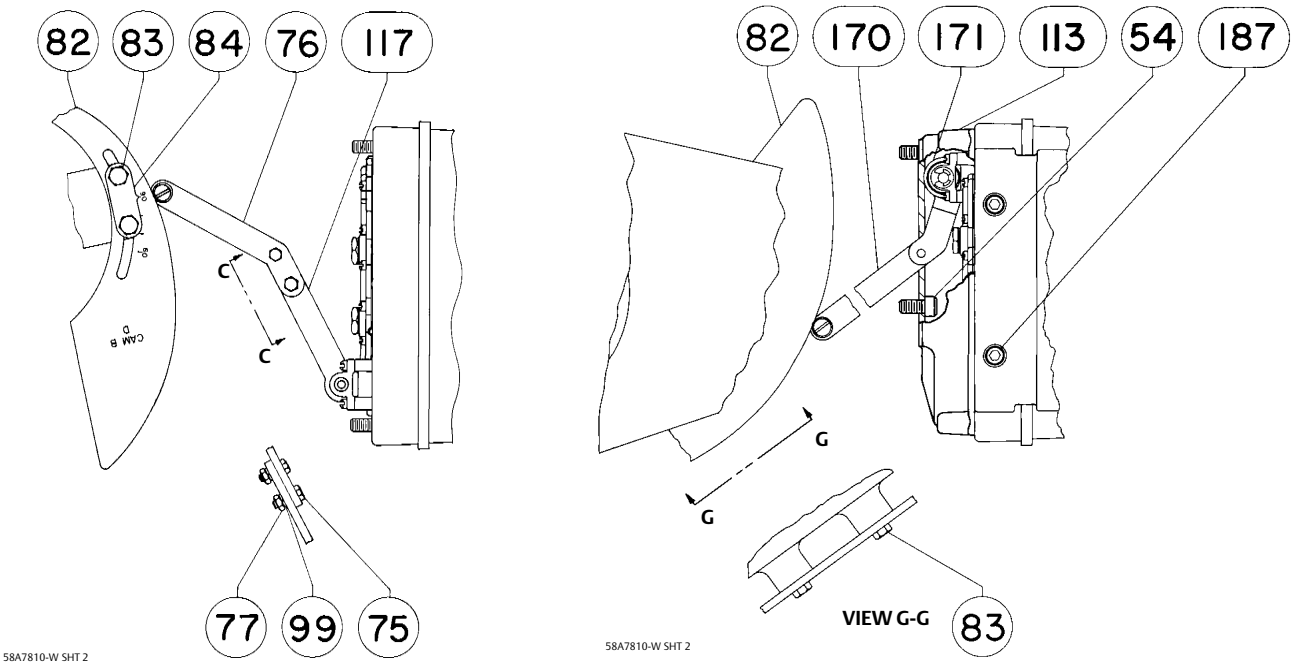
Figure 29. Feedback Assemblies for Fisher 3610J, 3610JP, 3620J, and 3620JP Positioners



**3610J AND 3620J POSITIONERS**  
**FOR 1051 ACTUATORS SIZE 40 AND 60**  
**FOR 1052 ACTUATORS SIZE 40, 60, AND 70**  
**3610JP AND 3620JP POSITIONERS**  
**FOR 1061 ACTUATORS SIZE 30-60**

**3610J AND 3620J POSITIONERS**  
**FOR ALL 1051 AND 1052 ACTUATORS**  
**3610JP AND 3620JP POSITIONERS**  
**FOR 1061 ACTUATORS SIZE 30-60**

**3610J AND 3620J POSITIONERS**  
**FOR 1051 ACTUATOR SIZE 33**  
**FOR 1052 ACTUATORS SIZE 20 AND 33**

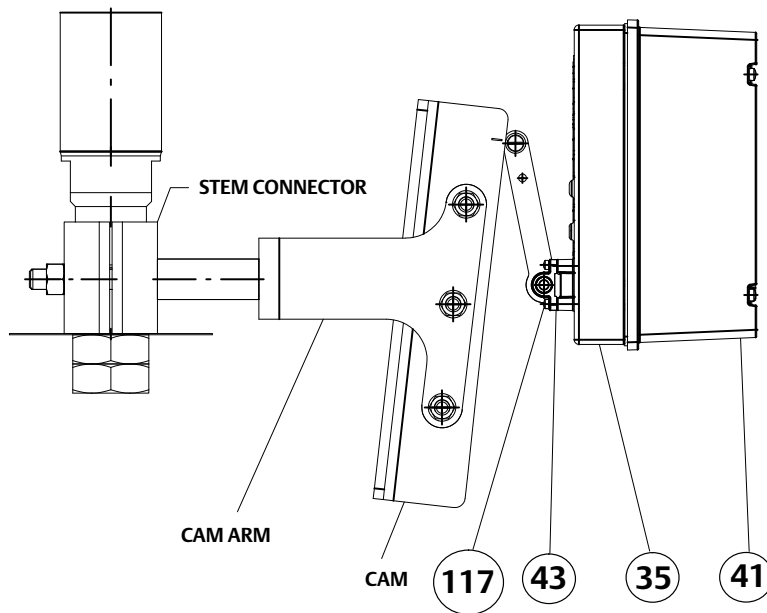
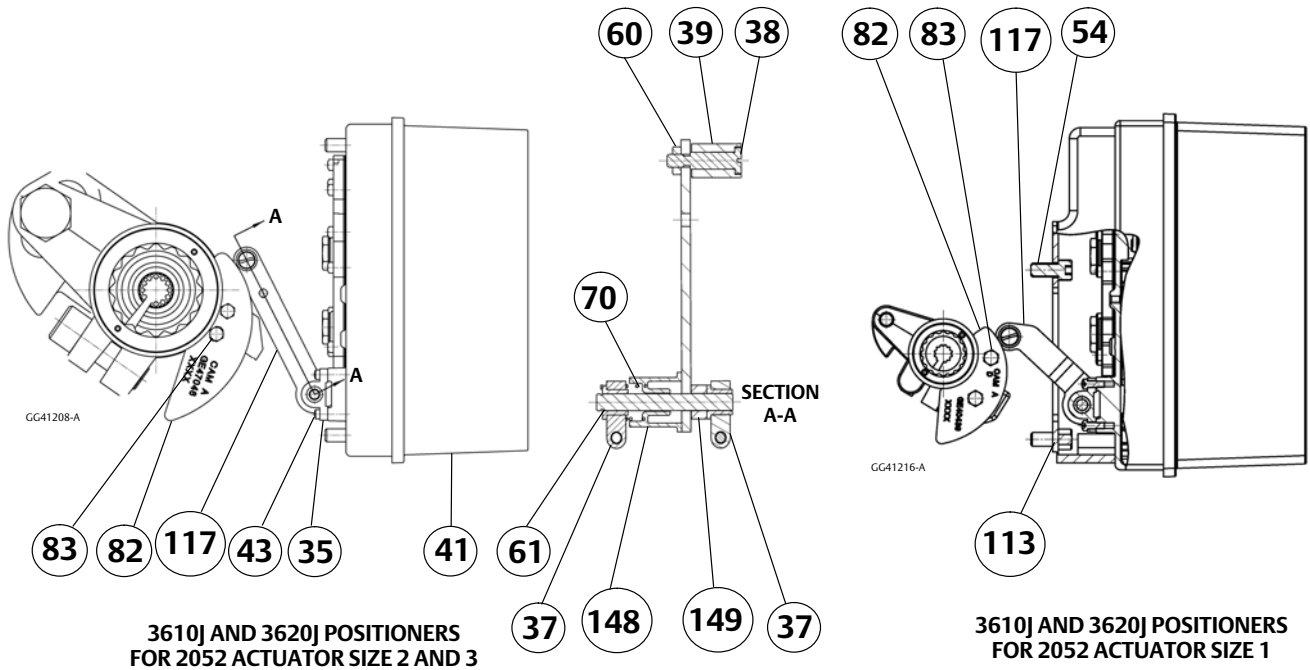


**3610JP AND 3620JP POSITIONERS**  
**FOR 1061 ACTUATORS SIZE 80 - 100**

**3610JP AND 3620JP POSITIONERS**  
**FOR 1069 ACTUATORS SIZE 100**

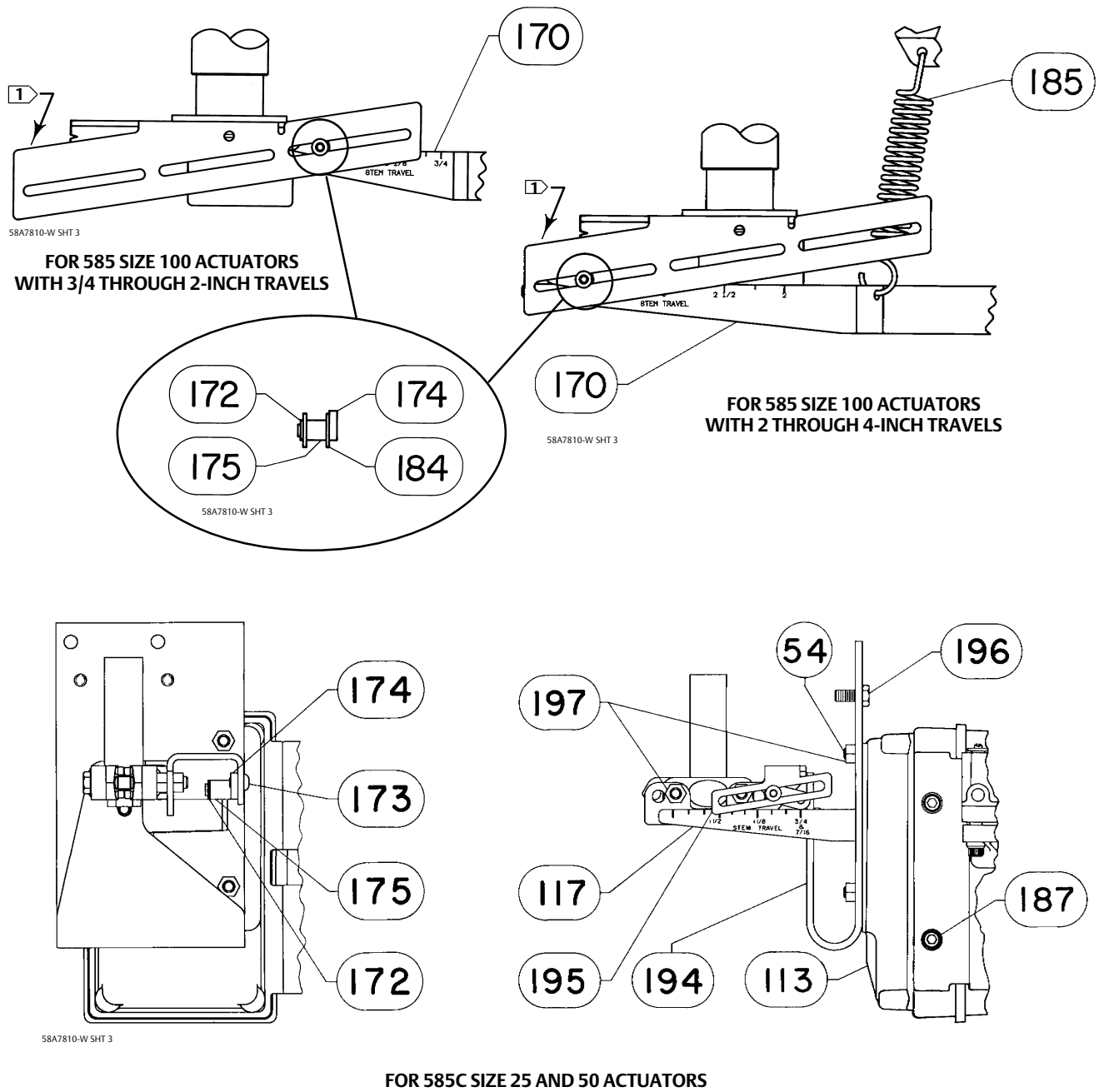


Figure 29. Feedback Assemblies for Fisher 3610J, 3610JP, 3620J, and 3620JP Positioners (Continued)



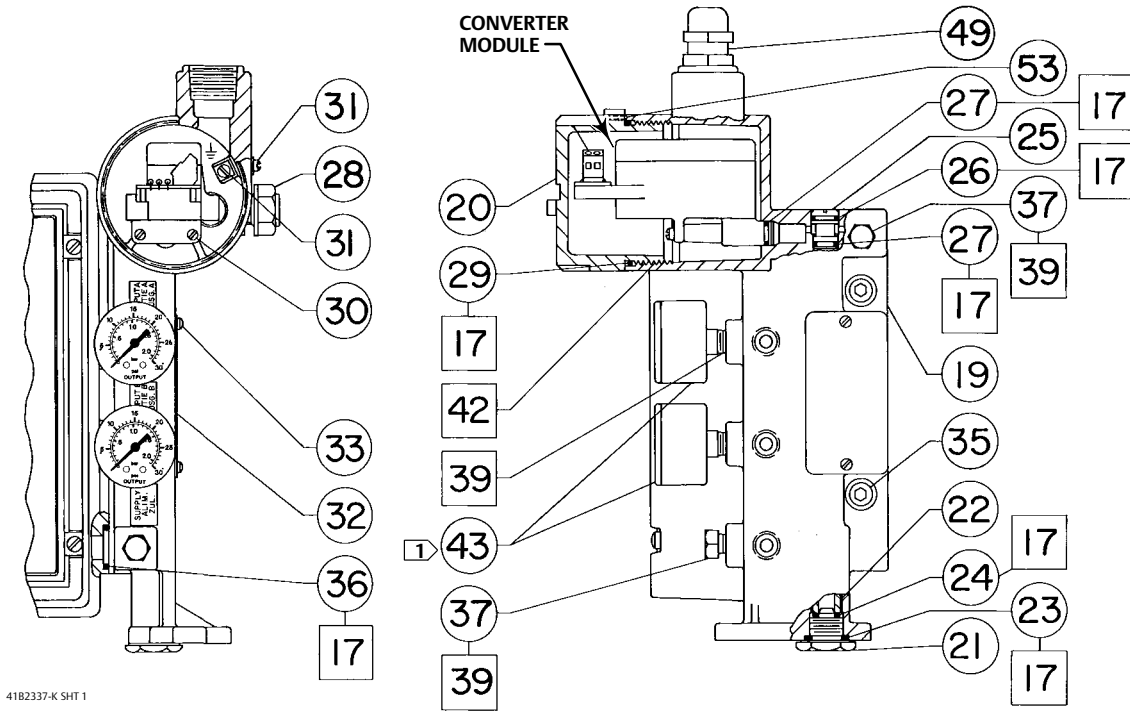
**3610JP AND 3620JP POSITIONERS FOR 585C SIZE 60 AND ABOVE**  
FOR OTHER ACTUATORS REFER TO THE SPECIFIC MOUNTING KIT ASSEMBLY DRAWING FOR DETAILS

Figure 30. Feedback Assemblies for Fisher 3611JP and 3621JP Positioners



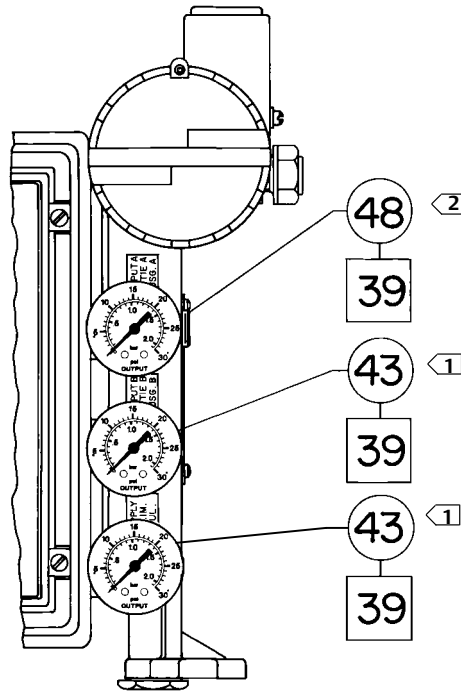
NOTE:  
 [1] FOR THE STEM BRACKET ASSEMBLY, REFER TO THE ACTUATOR INSTRUCTION MANUAL.

Figure 31. Fisher 3622 Electro-Pneumatic Converter Assembly



4182337-K SHT 1

3620JP POSITIONERS



4182337-K SHT 2

3620J POSITIONER WITH GAUGES

□ APPLY LUBRICANT OR SEALANT

NOTE:

1 GAUGES MAY BE REPLACED BY PIPE PLUGS (KEY 37) OR TIRE VALVES (KEY 41)

2 KEY 48 IS USED FOR 3620J POSITIONER ONLY

Neither Emerson, Emerson Automation Solutions, nor any of their affiliated entities assumes responsibility for the selection, use or maintenance of any product. Responsibility for proper selection, use, and maintenance of any product remains solely with the purchaser and end user.

Fisher and FlowScanner are marks owned by one of the companies in the Emerson Automation Solutions business unit of Emerson Electric Co. Emerson Automation Solutions, Emerson, and the Emerson logo are trademarks and service marks of Emerson Electric Co. All other marks are the property of their respective owners.

The contents of this publication are presented for informational purposes only, and while every effort has been made to ensure their accuracy, they are not to be construed as warranties or guarantees, express or implied, regarding the products or services described herein or their use or applicability. All sales are governed by our terms and conditions, which are available upon request. We reserve the right to modify or improve the designs or specifications of such products at any time without notice.

Emerson Automation Solutions  
Marshalltown, Iowa 50158 USA  
Sorocaba, 18087 Brazil  
Cernay, 68700 France  
Dubai, United Arab Emirates  
Singapore 128461 Singapore

[www.Fisher.com](http://www.Fisher.com)

