

# 4660 High-Low Pressure Pilot

## Contents

Introduction .....	1
Scope of Manual .....	1
Description .....	4
Educational Services .....	4
Specifications .....	4
Installation .....	4
Mounting .....	5
Actuator Mounting .....	5
Panel Mounting .....	5
Pipestand Mounting .....	7
Pressure Connections .....	7
Supply Pressure .....	7
Process Pressure .....	8
Output Pressure .....	8
Vent .....	8
Operating Information .....	8
Pilots without Optional Set Point Indication ...	9
Preliminary Adjustments .....	9
Setting the High Set Point .....	9
Setting the Low Set Point .....	10
Alternate Set Point	
Adjustment Procedure .....	10
Pilots with Optional Set Point Indication .....	11
Setting the High and/or Low Set Point(s) ..	11
Prestartup Checks .....	12
Alignment of the Nozzle Beam .....	12
Startup .....	12
Performance .....	13
Principle of Operation .....	13
Maintenance .....	14
Bourdon Tube/Flapper Assembly	
Replacement .....	14
Block-and-Bleed Relay Assembly	
Replacement .....	14
Low or High Set Point Assembly	
Replacement .....	15
Pilots without Set Point Indication .....	15
Pilots with Set Point Indication .....	15
Parts Ordering .....	16
Parts Kits .....	16
Parts List .....	18



FRONT VIEW

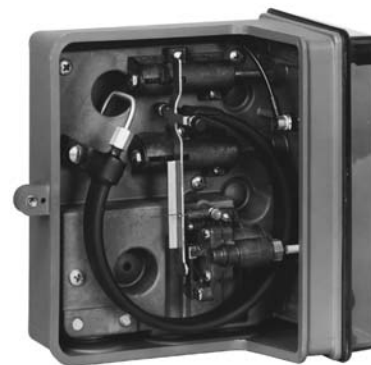

LEFT SIDE WITH CASE COVER OFF

Figure 1. 4660 High-Low Pressure Pilot with Relay

## Introduction



### Scope of Manual

This instruction manual provides installation, operating, maintenance, and parts ordering information for the 4660 high-low pressure pilot. Refer to separate instruction manuals for information regarding the control valve actuator.



# 4660 Pressure Pilot

Table 1. Specifications

<p><b>Available Configurations</b> High-low, low-only, or high-only set point capability</p> <p><b>Input Signal</b> <b>Type:</b> Process pressure sensed with Bourdon tube <b>Bourdon Tube Ratings:</b> See table 2 or 3 <b>Overpressure Protection:</b> Maximum allowable emergency process pressures and maximum allowable process pressures to ensure set point readjustability are shown in table 4</p> <p><b>Output Signal</b> Zero or full supply pressure (automatically resets)</p> <p><b>Supply Pressure<sup>(1)</sup></b> <b>Normal Operating Pressures:</b> 1.4 to 4.4 bar (20 to 65 psig) <b>Medium:</b> Air or natural gas <i>Air Quality:</i> Supply pressure must be clean, dry air that meets the requirements of ISA Standard 7.0.01. A maximum 40 micrometer particle size in the air system is acceptable. Further filtration down to 5 micrometer particle size is recommended. Lubricant content is not to exceed 1 ppm weight (w/w) or volume (v/v) basis. Condensation in the air supply should be minimized <i>Natural Gas:</i> Natural gas must be clean, dry, oil-free, and noncorrosive. H<sub>2</sub>S content should not exceed 20 ppm.</p> <p><b>Steady-State Air Consumption<sup>(2,3)</sup></b> <b>Output Signal at Zero:</b> ≤0.134 normal m<sup>3</sup>/hr≤ (5 scfh) <b>Output Signal at Full Supply Pressure:</b> ≤0.00134 normal m<sup>3</sup>/hr≤ (0.05 scfh)</p> <p><b>Set Point Adjustments</b> Continuously adjustable between 3 and 97% of Bourdon tube rating; see table 2 or 3 for ranges</p> <p><b>Performance in Percentage of Bourdon Tube Rating</b> <b>Repeatability</b> ≤0.25% <b>Set Point <math>\Delta P_{min}</math> (see table 2 or 3)</b> <i>Single High-Low Unit:</i> 10% for up to 172.4 bar (2500 psig) Bourdon tubes; 15% for 344.8 and 517.1 bar (5000 and 7500 psig) Bourdon tubes</p>	<p><i>Low-Only and High-Only Pair:</i> 3% <b>Trip-to-Reset Zone (see table 2 or 3)</b> ≤1.5%</p> <p><b>Exhaust Capacity</b> <math>C_g \geq 15</math></p> <p><b>Pilot Supply Flow Requirement<sup>(2)</sup></b> Pilot requires minimum of 4.02 normal m<sup>3</sup>/hr (150 scfh) to activate relay</p> <p><b>Operating Conditions<sup>(1)</sup></b></p> <table border="1" style="width: 100%;"> <thead> <tr> <th>Condition</th> <th>Normal Operating Limits</th> <th>Nominal Reference</th> </tr> </thead> <tbody> <tr> <td rowspan="3">Ambient temperature</td> <td>Nitrile Elastomers: -40 to 60°C (-40 to 140°F)</td> <td rowspan="3">21°C (70°F)</td> </tr> <tr> <td>Fluorocarbon Elastomers: -7 to 71°C (20 to 160°F)</td> </tr> <tr> <td>Fluorosilicone Elastomers: (Low Temperature Version) -59 to 71°C (-75 to 160°F)</td> </tr> <tr> <td>Process temperature</td> <td>-29 to 93°C (-20 to 200°F)</td> <td>21°C (70°F)</td> </tr> </tbody> </table> <p><b>Operating Influences on Switch Point Sensitivity</b> <b>Supply Pressure:</b> ≤0.05% of Bourdon tube rating for a 10% change in supply pressure <b>Ambient Temperature:</b> ≤1.5% (standard construction) or ≤2% (low temperature construction) of Bourdon tube rating throughout normal operating limits with nominal reference <b>Time:</b> ≤1% of Bourdon tube rating over 30 days at ambient temperature nominal reference <b>Process Pressure:</b> Range shift or set point drift can occur if process pressure exceeds Bourdon tube rating</p> <p><b>Pressure Connections</b> 1/4 NPT internal</p> <p><b>Mounting</b> Panel, rack, pipestand, or actuator</p> <p><b>Hazardous Area Classification</b> Complies with the requirements of ATEX Group II Category 2 Gas and Dust</p> <p>  II 2 G D</p>	Condition	Normal Operating Limits	Nominal Reference	Ambient temperature	Nitrile Elastomers: -40 to 60°C (-40 to 140°F)	21°C (70°F)	Fluorocarbon Elastomers: -7 to 71°C (20 to 160°F)	Fluorosilicone Elastomers: (Low Temperature Version) -59 to 71°C (-75 to 160°F)	Process temperature	-29 to 93°C (-20 to 200°F)	21°C (70°F)
Condition	Normal Operating Limits	Nominal Reference										
Ambient temperature	Nitrile Elastomers: -40 to 60°C (-40 to 140°F)	21°C (70°F)										
	Fluorocarbon Elastomers: -7 to 71°C (20 to 160°F)											
	Fluorosilicone Elastomers: (Low Temperature Version) -59 to 71°C (-75 to 160°F)											
Process temperature	-29 to 93°C (-20 to 200°F)	21°C (70°F)										

-continued-

Table 1. Specifications (continued)

<p><b>Approximate Weight</b></p> <p>2.3 kg (5 pounds)</p> <p><b>Options</b></p> <ul style="list-style-type: none"> <li>■ Visual output indication, ■ fluorocarbon elastomers in relay, ■ low-temperature version to -59°C (-75°F), ■ 316 stainless steel panel mounting flange, ■ set point indication, ■ tamper-resistant front cover</li> </ul>	<p><b>Declaration of SEP</b></p> <p>Fisher Controls International LLC declares this product to be in compliance with Article 3 paragraph 3 of the Pressure Equipment Directive (PED) 97 / 23 / EC. It was designed and manufactured in accordance with Sound Engineering Practice (SEP) and cannot bear the CE marking related to PED compliance.</p> <p>However, the product <i>may</i> bear the CE marking to indicate compliance with <i>other</i> applicable European Community Directives.</p>
---	---

NOTE: Specialized instrument terms are defined in ANSI/ISA Standard 51.1 - Process Instrument Terminology.  
 1. The pressure and temperature limits in this document and any applicable standard or code limitation should not be exceeded.  
 2. Normal m<sup>3</sup>/hr—normal cubic meters per hour (0°C and 1.01325 bar absolute). Scfh—standard cubic feet per hour (60°F and 14.7 psia).  
 3. Supply pressure at 2.4 bar (35 psig).

Table 2. Additional Specifications, Bar

BOURDON TUBE RATING <sup>(1)</sup>	SET RANGE <sup>(1)</sup>	SET POINT ΔP <sub>MIN</sub> (MINIMUM ALLOWABLE DIFFERENCE BETWEEN HIGH AND LOW SETTINGS)		TRIP-TO-RESET ZONE
		Single High-Low Unit	High-Only/ Low-Only Pair	
6.9	0.3 to 6.6	0.7	0.3	0.2
17.2	0.6 to 16.6	1.7	0.6	0.3
34.5	1.1 to 33.4	3.5	1.1	0.6
69.0	2.1 to 67.9	6.9	2.1	1.1
103.4	3.2 to 100.2	10.4	3.2	1.6
172.4	5.2 to 167.2	17.3	5.2	2.6
344.8	10.4 to 334.4	34.5	10.4	5.2
517.2	15.6 to 501.5	51.8	15.6	7.8
689.5 <sup>(2)</sup>	20.7 to 668.8	103.4	20.7	10.3

1. Rating indicated on Bourdon tube and set range on front panel are in kPa (1 bar = 100 kPa).  
 2. Available in N05500 only, for NACE MR0175-2002.

Table 3. Additional Specifications, Psig

BOURDON TUBE RATING	SET RANGE	SET POINT ΔP <sub>MIN</sub> (MINIMUM ALLOWABLE DIFFERENCE BETWEEN HIGH AND LOW SETTINGS)		TRIP-TO-RESET ZONE
		Single High-Low Unit	High-Only/ Low-Only Pair	
100	3 to 97	10	3.0	1.5
250	8 to 242	25	7.5	3.8
500	15 to 485	50	15.0	7.5
1000	30 to 970	100	30.0	15.0
1500	45 to 1455	150	45	23
2500	75 to 2425	250	75	38
5000	150 to 4850	750	150	75
7500	225 to 7275	1025	225	113
10,000 <sup>(1)</sup>	300 to 9700	1500	300	150

1. Available in N05500 only, for NACE MR0175-2002.

Table 4. Maximum Allowable Process Pressure<sup>(1)</sup>

BOURDON TUBE RATING		MAXIMUM ALLOWABLE EMERGENCY PROCESS PRESSURE			
		Stainless Steel Bourdon Tubes		N05500 Bourdon Tubes (NACE MR0175-2002)	
Bar <sup>(2)</sup>	Psig	Bar <sup>(2)</sup>	Psig	Bar <sup>(2)</sup>	Psig
6.9	100	13.8	200	13.8	200
17.2	250	34.2	500	34.2	500
34.5	500	69.0	1000	69.0	1000
69.0	1000	138.0	2000	138.0	2000
103.4	1500	206.8	3000	206.8	3000
172.4	2500	344.8	5000	258.6	3750
344.8	5000	517.2	7500	430.9	6250
517.2	7500	646.3	9375	568.8	8250
689.5	10,000	N/A	N/A	758.5	11,000
MAXIMUM ALLOWABLE PROCESS PRESSURE TO INSURE SET POINT READJUSTABILITY <sup>(3)</sup>					
6.9	100	13.8	200	13.8	200
17.2	250	34.8	500	22.3	325
34.5	500	51.7	750	53.4	775
69.0	1000	103.5	1500	89.7	1300
103.4	1500	155.1	2250	124.0	1800
172.4	2500	172.4	2500	227.5	3300
344.8	5000	517.2	7500	344.8	5000
517.2	7500	646.3	9375	517.2	7500
689.5	10,000	N/A	N/A	689.5	10,000

1. Normal operating process pressures should not exceed the Bourdon tube rating.  
 2. Ratings indicated on Bourdon tube are in psig and kPa (1 bar = 100 kPa).  
 3. Values listed for the N05500 Bourdon tubes are for a 2% deviation from set point due to overpressure.

Do not install, operate or maintain a 4660 high-low pressure pilot without first ● being fully trained and qualified in valve, actuator and accessory installation, operation and maintenance, and ● carefully reading and understanding the contents of this manual. If you have any questions about these instructions, contact your Emerson Process Management™ sales office.

**Description**

The 4660 high-low pressure pilot (figure 1) activates emergency shutdown systems for flowlines, production vessels, and compressors. The pilot can be used with either a single or dual set point capability to maintain full output pressure when the process is operating within the set point range. The primary switching mechanism in this pilot is a block-and-bleed relay assembly.

Unless otherwise noted, all NACE references are to NACE MR0175-2002.

**Specifications**

Specifications for the 4660 high-low pressure pilot are listed in table 1.

**Educational Services**

For information on available courses for the 4660 high-low pressure pilot, as well as a variety of other products, contact:

Emerson Process Management  
 Educational Services, Registration  
 P.O. Box 190; 301 S. 1st Ave.  
 Marshalltown, IA 50158-2823  
 Phone: 800-338-8158 or  
 Phone: 641-754-3771  
 FAX: 641-754-3431  
 e-mail: education@emersonprocess.com

**Installation**

If using natural gas as the pneumatic supply medium, natural gas will be used in the pressure connections of the unit to any connected equipment. The unit will vent natural gas into the surrounding atmosphere, unless it is remote vented.



**To avoid personal injury or property damage caused by a sudden release of pressure:**

- **Always wear protective clothing, gloves, and eyewear when performing any installation operations.**

- **Personal injury or property damage may result from fire or explosion if natural gas is used as the supply medium and preventative measures are not taken. Preventative measures may include: Remote venting of the unit, re-evaluating the hazardous area classification, ensuring adequate ventilation, and the removal of any ignition sources. For information on remote venting of this controller/transmitter, refer to page 8.**

- **Do not exceed the process pressure values in table 4 or the maximum supply pressure values in table 1.**

- **If installing into an existing application, also refer to the WARNING at the beginning of the Maintenance section in this instruction manual.**

- **Check with your process or safety engineer for any additional measures that must be taken to protect against process media**

The following instructions describe various mounting and connecting procedures. Pilots may be connected together to accommodate requirements for single and dual outputs as well as single and dual process pressure lines. Figure 2 shows some typical connections. When a pair of high-only and low-only pilots are used to obtain closer set points as specified by the set point  $-\Delta P_{MIN}$  values in tables 2 and 3 connect the pilots as shown in examples A and D in figure 2. For a two-segment flow line configuration that adheres to API Specification RP14C, connect as shown in example B or C.

## Mounting

Normal installation is with the pilot mounted vertically and with process, supply, and output connections

facing downward as shown in figure 1. All key numbers are shown in figure 8 unless otherwise indicated.

### **Actuator Mounting**

Pilots can be mounted on a control valve actuator as described below.

To yoke-mount the pilot to an actuator, attach the two-holed side of the yoke mounting plate (key 75, not shown) to the spring barrel of the actuator with cap screws and lockwashers (keys 84 and 85, not shown). Then attach the three-bossed side of the pilot case (key 2) to the three-holed side of the yoke mounting plate with the remaining cap screws and lock washers.

To mount the pilot to the diaphragm casing of an actuator, attach the two-holed side of the casing mounting plate (key 75, not shown) to the diaphragm casing of the actuator with the actuator cap screws and nuts. Then attach the three-bossed side of the pilot case (key 2) to the three-holed side of the casing mounting plate with cap screws and lock washers (keys 84 and 85, not shown).

### **Panel Mounting**

If the pilot is not already equipped with a panel mounting plate (key 75), remove the cover screws (key 6), the cover (key 4), and the screws (key 21).

For pilots without set point indication, loosen the set screws and remove the knobs (key 67), the locking disks (key 69), and the front plate (key 74). Insert the panel mounting plate, and reattach the front plate, the locking disks, the knobs, the cable assembly (key 12), the screws, the cover, and the cover screws.

For pilots with set point indication, loosen the module set screws, and remove the modules and the front plate (key 74). Insert the panel mounting plate, and reattach the front plate, the modules, the cable assembly (key 12), the screws, the cover, and the cover screws.

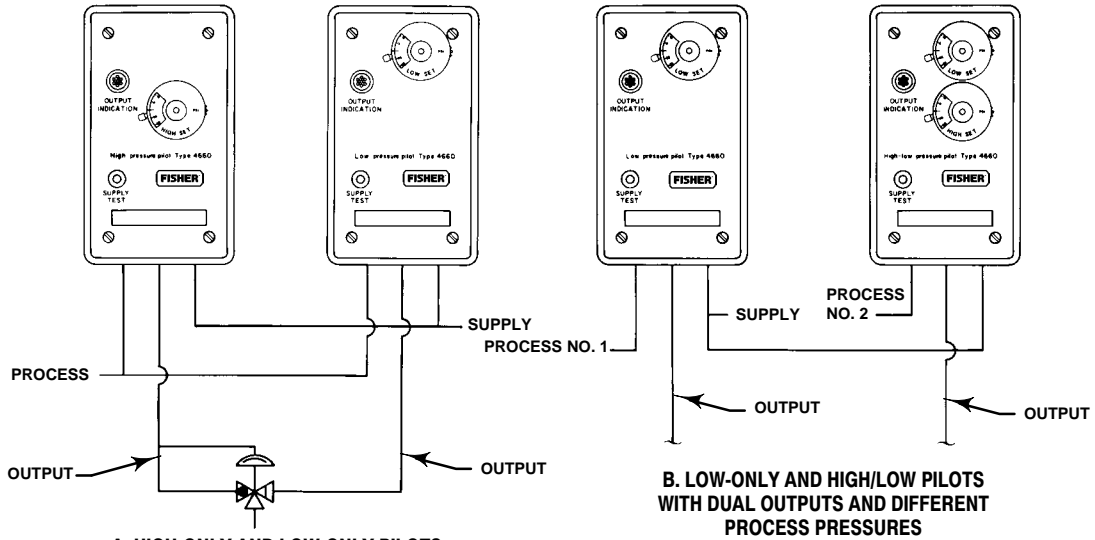

**B. LOW-ONLY AND HIGH/LOW PILOTS WITH DUAL OUTPUTS AND DIFFERENT PROCESS PRESSURES**

38A6084-B

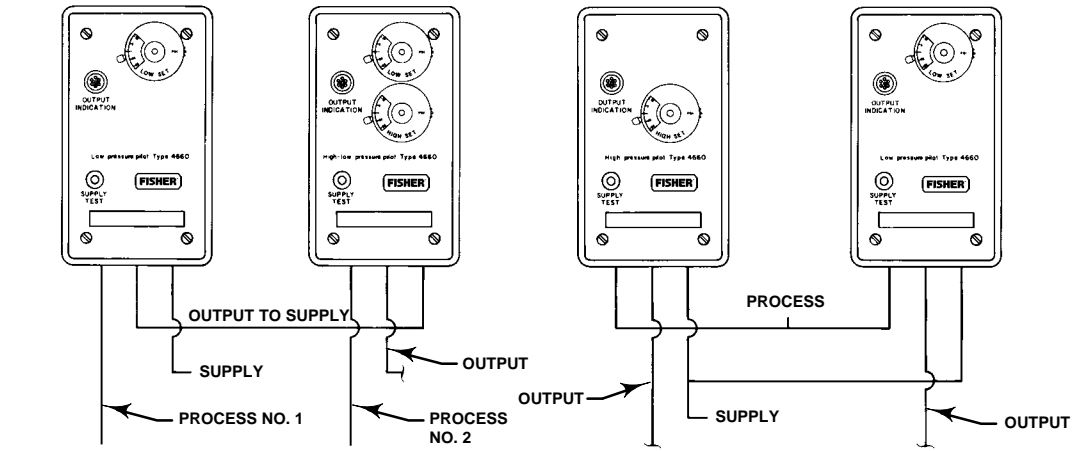

**D. LOW-ONLY AND HIGH-ONLY PILOTS WITH DUAL OUTPUTS AND COMMON PROCESS PRESSURE**

38A6086-B

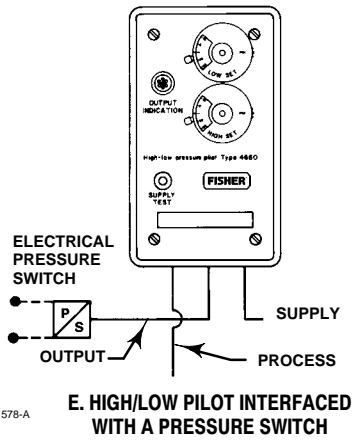

Figure 2. Typical Connection Schematics



# 4660 Pressure Pilot

**most applications, check with an Emerson Process Management field office and industry instrument air quality standards for use with corrosive gas or if you are unsure about the proper amount or method of air filtration or filter maintenance.**

Supply pressure must be clean, dry air or noncorrosive gas that meets the requirements of ISA Standard 7.0.01. A maximum 40 micrometer particle size in the air system is acceptable. Further filtration down to 5 micrometer particle size is recommended. Lubricant content is not to exceed 1 ppm weight (w/w) or volume (v/v) basis. Condensation in the air supply should be minimized. Alternatively, natural gas may be used as the supply pressure medium. Gas must be clean, dry, oil-free, and noncorrosive. H<sub>2</sub>S content should not exceed 20 ppm.

Use a suitable filter regulator, such as the 67CFR regulator with standard 5 micron filter, to remove solid particles and to maintain the supply pressure source within the normal operating range of 1.4 to 4.4 bar (20 to 65 psig). Refer to table 1 for the pilot supply flow requirement (relay construction only). As shown in figure 4, connect supply pressure to the connection marked SUPPLY on the bottom of the pilot case.

## Process Pressure

Connect process pressure to the connection marked PROCESS on the bottom of the pilot case as shown in figure 4. When installing process pressure piping, follow accepted practices to ensure accurate transmission of the process pressure to the pilot. Install shutoff valves, vents, drains, or seal systems as needed in the process pressure line. Install a needle valve in the process pressure line to dampen pulsations.

## Output Pressure

Connect output pressure piping to the connection marked OUTPUT on the bottom of the pilot case as shown in figure 4. Refer to the appropriate control valve or actuator instruction manual to complete the connection of output pressure piping from the pilot to the loading connection of the control valve actuator.

## Vent



**Personal injury or property damage could result from fire or explosion of accumulated gas, or from contact with hazardous gas, if a flammable or hazardous gas is used as the supply pressure medium. Because the instrument case and cover assembly do not form a gas-tight seal when the assembly is enclosed, a remote vent line, adequate ventilation, and necessary safety measures should be used to prevent the accumulation or flammable or hazardous gas. A remote vent pipe alone cannot be relied upon to remove all flammable and hazardous gas.**

**Vent line piping should comply with local and regional codes, should have adequate inside diameter, and should be as short as possible to reduce case pressure buildup.**

If a remote vent is required, use 19 mm (3/4-inch) (minimum inside diameter) pipe for runs up to 6.09 meters (20 feet). For vent piping runs from 6.09 to 30.5 meters (20 to 100 feet), use 25.4 mm (1-inch) (minimum inside diameter) pipe. Remove the vent screen (key 20, figure 8) and install a remote vent pipe to exhaust the vented gas to a safe, well-ventilated area. The vent, as shown in figure 8, or the end of a remote vent pipe must be protected against the entrance of all foreign matter that could block the vent. Check the vent periodically to be certain it is not plugged.

## Operating Information

For high-only and low-only constructions, perform the procedures that are outlined in the adjustments portion of this section. For high-only constructions, perform only those procedures that pertain to setting and checking the high set point. For low-only constructions, perform only those procedures that pertain to setting and checking the low set point. For high-low constructions, perform procedures that pertain to both the high and low set points.

 **WARNING**

**Avoid personal injury or property damage from an uncontrolled process or sudden release of process pressure. Before starting any adjustments:**

- Always wear protective clothing, gloves, and eyewear to avoid personal injury when making adjustments.
- Provide some temporary means of process control before taking the pilot out of service.
- Shut off the process pressure line and the supply pressure line, and bleed all of the supply pressure.
- Bleed all process pressure from the pilot so that no pressure is contained in the Bourdon tube.
- When bleeding the supply or process pressure, natural gas, if used as the supply medium, will seep from the unit into the surrounding atmosphere. Personal injury or property damage may result from fire or explosion if preventative measures are not taken, such as adequate ventilation and the removal of any ignition sources.
- Use lock-out procedures to be sure that the above measures stay in effect while you are working on the equipment.
- Check with your process or safety engineer for any additional measures that must be taken to protect against process media.

**Pilots Without Optional Set Point Indication**

***Preliminary Adjustments***

Make sure each of the following six steps have been performed completely before setting either the high or low set point pressures. Key numbers are shown in figure 8.

1. Refer to the WARNING at the beginning of the Operating Information section. Make sure the Bourdon tube contains no pressure.
2. Install either a pressure gauge or an optional output indicator in the output pressure line.
3. Remove the cover screws and the cover (keys 6 and 4).
4. Unlock each locking disk (key 69) that holds each set point knob in place. Turn the HIGH SET knob clockwise until it has reached the end of its travel. Turn the LOW SET knob (key 67) counterclockwise until it has reached the end of its travel.
5. Turn on the supply pressure. To check that the supply pressure is turned on, push the SUPPLY TEST button located in the cleanout assembly (key 54) on the front plate (key 74) until a flow sound is heard.

 **WARNING**

**To avoid personal injury or property damage caused by a sudden release of pressure, do not exceed the process pressure values in table 4.**

6. Connect an external pressure source to the process pressure connection. This external pressure source should be a regulated air or gas supply that is adjustable to zero. The external pressure source must be capable of supplying a process pressure that will be equal to or greater than the desired high set point pressure.
7. Continue with the appropriate procedures described below. Replace the cover and cover screws after all adjustments are completed.

***Setting the High Set Point***

**Note**

**To ensure that full output pressure will be indicated during the following steps, make sure the previous six steps of the Preliminary Adjustments portion of this section have been completed before proceeding.**

 **WARNING**

**To avoid personal injury or property damage caused by a sudden release of pressure, do not exceed the Bourdon Tube rating (see tables 2 and 3).**

# 4660 Pressure Pilot

To set the high set point pressure, perform the following three steps:

1. Adjust the external pressure source to the desired high set point pressure.
2. Check that full output pressure is being registered by using a pressure gauge installed in the output pressure line or by using the optional output indicator (key 88). The optional output indicator shows a green color when the output pressure is at full pressure and black when the output pressure is at zero.
3. Slowly turn the HIGH SET knob counterclockwise until the desired high set point is obtained. The high set point is obtained when the output pressure of the pilot has changed from full output to zero.
4. Lock the locking disk (key 69).

## Setting the Low Set Point

### Note

To ensure that full output pressure will be indicated during the following steps:

- Make sure that the first six steps of the Preliminary Adjustments portion of this section have been completed before proceeding, and
- Make sure the difference between the high set point pressure and the low set point pressure is greater than or equal to the appropriate Set Point  $\Delta P_{MIN}$  value specified in tables 2 and 3.

To set the low set point pressure, perform the following three steps:

1. Adjust the external pressure source to the desired low set point pressure.
2. Check that full output pressure is being registered by using a pressure gauge installed in the output pressure line or by using the optional output indicator (key 88). The optional output indicator shows a green color when the output pressure is at full pressure and black when the output pressure is at zero.
3. Slowly turn the low set point knob (key 67) clockwise until the low set point is obtained. The low set point is obtained when the output pressure of the pilot has changed from full output to zero.
4. Lock the locking disk (key 69).

Table 5. Alternate Set Point Adjustment

BOURDON TUBE RATING		PRESSURE CHANGE PER DOT <sup>(1)</sup>		PRESSURE CHANGE PER REVOLUTION	
bar	Psig	bar	Psig	bar	Psig
3.4	50	0.1	1	0.4	6
6.9	100	0.1	2	0.8	12
17.2	250	0.4	5	2.1	30
34.5	500	0.7	10	4.1	60
69.0	1000	1.4	20	8.3	120
103.4	1500	2.1	30	12.4	180
172.4	2500	3.4	50	20.7	300
344.8	5000	6.9	100	41.4	600
517.2	7500	10.3	150	62.1	900
689.5	10,000	13.8	200	82.7	1200

1. Six dots per revolution.

## Alternate Set Point Adjustment Procedure

This procedure may be used to closely approximate the desired high and low set points when no external pressure source is available to simulate process pressure. If the pilot does not have the optional output indicator (key 88), provide a means of indicating the output pressure. Refer to figure 5.

For high-low constructions, perform steps 2 through 7. For high-only constructions, perform steps 2, 4, and 5. For low-only constructions, perform steps 2, 3, 6, and 7.

### Note

**Make sure the first 6 steps of the Preliminary Adjustments portion of this section have been completed before proceeding.**

1. Refer to the WARNING at the beginning of the Operating Information section. Make sure the Bourdon tube contains no pressure.
2. Connect supply pressure to the pilot.
3. Turn on the supply pressure. To check that the supply pressure is on, press the SUPPLY TEST button in the cleanout assembly (key 54) until a flow sound is heard.
4. Turn the LOW SET knob counterclockwise until it has reached the end of its travel.

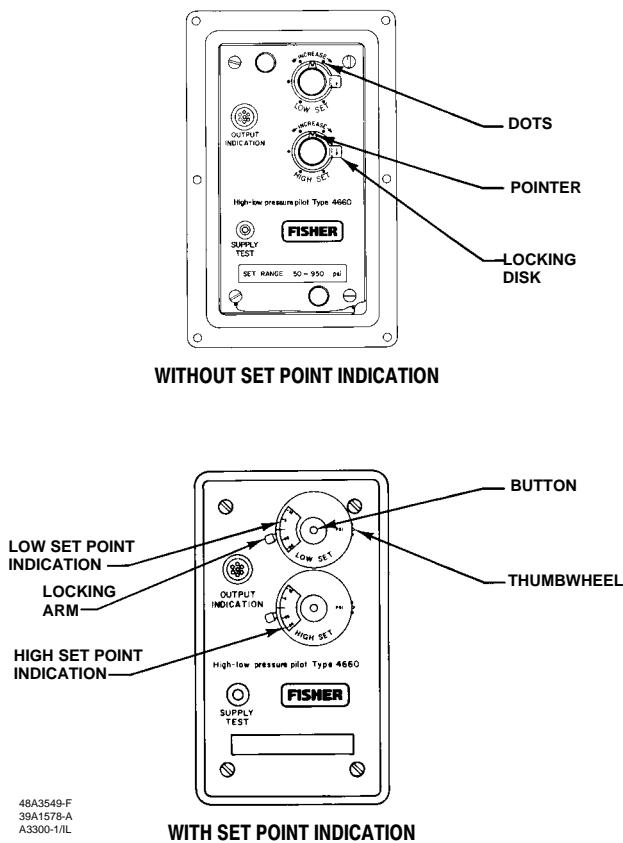

Figure 5. Set Point Adjustment Detail

5. Turn the HIGH SET knob counterclockwise until the high set point pivot just comes in contact with the flapper. The pilot should have full output pressure (green indication on the optional output indicator).
6. Refer to table 5 and turn the HIGH SET knob clockwise to correspond to the desired set point value. For example, with a 690 kPa (100 psig) Bourdon tube, turn the knob five revolutions for a desired high set point of 415 kPa (60 psig).
7. Turn the LOW SET knob clockwise until the low set point pivot just comes in contact with the flapper, moving the nozzle beam off the nozzle. The pilot should have zero output pressure (black indication on the optional output indicator).
8. Refer to table 5 and turn the LOW SET knob clockwise to the desired set point value. For example, with a 690 kPa (100 psig) Bourdon tube, turn the knob two revolutions for a desired low set point of 165 kPa (24 psig).
9. Lock the locking disks (key 69).

### Pilots With Optional Set Point Indication

Make sure each of the following five steps have been performed completely before setting the high and/or low set point pressures. Key numbers are shown in figure 8.

1. Refer to the WARNING at the beginning of the Operating Information section. Make sure the Bourdon tube contains no pressure.
2. Install either a pressure gauge or an optional output indicator (key 88) in the output pressure line.
3. Remove the cover screws (key 6) and the cover (key 4).
4. Turn on the supply pressure. To check that the supply pressure is turned on, press the SUPPLY TEST button located in the cleanout assembly (key 54) until a flow sound is heard.

### ⚠ WARNING

**To avoid personal injury or property damage caused by a sudden release of pressure, do not exceed the process pressure values in table 4.**

5. Connect an external pressure source to the process pressure connection. This external pressure source should be a regulated air or gas supply that is adjustable to zero. The external pressure source must be capable of supplying a process pressure that will be equal to or greater than the desired high set point pressure.
6. Continue with the appropriate procedures described below. Replace the cover and cover screws after all adjustments are completed.

### Setting the High and/or Low Set Point(s)

1. Adjust the external process pressure source to the desired high or low set point. For example, if the pilot is to trip at 3.4 bar (50 psig), apply 3.4 bar (50 psig) to the pilot. Use a pressure gauge to measure the process pressure.
2. Rotate the locking arm clockwise to unlock the module. Slowly turn the HIGH SET or LOW SET knob until the pilot trips.
3. Push the small button in the center of the knob with a ball point pen or pencil and rotate the scale with the thumbwheel on the right hand edge of the module (see figure 5) until the number 50 aligns with

# 4660 Pressure Pilot

the mark on the left-hand edge of the module window.

4. Rotate the locking arm counterclockwise to lock the module.
5. Repeat steps 1, 2, and 3 for the other module, if specified.

## Prestartup Checks

Before using the pilot in an actual startup, verify that both the high and low set point pressures are set at the desired pressure settings.

### WARNING

**To avoid personal injury or property damage caused by a sudden release of pressure, do not exceed the Bourdon Tube rating (see tables 2 and 3).**

1. After the desired low set point pressure has been adjusted, increase the external pressure source pressure until the output pressure of the pilot is at full output. Do not exceed the set range (see tables 2 and 3) for the appropriate Bourdon tube range.
2. Increase the external pressure source pressure until the output pressure of the pilot has changed from full output to zero. Listen carefully. You will hear a quick change in sound when the output changes.
3. Compare the pressure of the external pressure source with the desired high set point setting.
4. If necessary, adjust the high set point pressure by turning the HIGH SET knob clockwise to increase and counterclockwise to decrease the high set point setting. Once the desired high set point is achieved, rotate the locking arm to the locked position.
5. Decrease the external pressure source until the output pressure of the pilot is again at full output.
6. Continue to decrease the external pressure source pressure until the output pressure of the pilot has changed from full output to zero. Listen carefully. You will hear a quick change in sound when the output changes.
7. Compare the pressure of the external pressure source with the desired low set point setting.
8. If necessary adjust the low set point pressure by turning the LOW SET knob (key 67) clockwise to increase and counterclockwise to decrease the low set point setting. Once the desired low set point is

achieved, rotate the locking arm to the locked position.

## Alignment of the Nozzle Beam

Perform this procedure before startup if the self-aligning disk of the nozzle beam is noticeably misaligned with respect to the nozzle area of the block-and-bleed relay (see figures 7 and 8). Key numbers are shown in figure 8.

1. Remove the case cover screw (key 5) and the case cover (key 3).
2. Lift the end of the flapper off the nozzle beam approximately 19 mm (0.75 inch) by moving the opposite end of the flapper clockwise for a slight rotation.

### CAUTION

**Be careful not to force the flapper such that the spring (key 18) will become damaged.**

3. Release the upper end of the flapper such that the flapper will snap back and contact the nozzle beam.
4. Replace the case cover, and attach it with the case cover screw.

## Startup

Verify that the desired high and/or low set point pressures have been set. Refer to the Mounting section for the desired pilot installation procedures.

CONSTRUCTION	PERCENT OF BOURDON TUBE RATING		
	Set Point $\Delta P_{MIN}$	Trip-to-Reset Zone	Repeat-ability
Single High-Low Unit	10 <sup>(1)</sup>	$\leq 1.5$	$\leq 0.25$
High-Only/Low-Only Pair	3		

1. 5000 and 7500 psig Bourdon tubes are 15 percent of Bourdon tube rating.

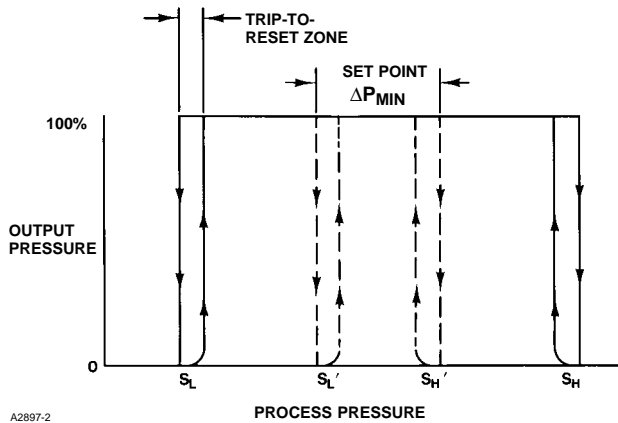

Figure 6. Performance Characteristics

Reduce the external process pressure source to zero and disconnect the source from the process pressure connection. Reconnect the process pressure line to the pilot and open the process pressure line from the process to the pilot. Reconnect the pilot output pressure line. When adjustments and startup have been completed, replace the cover (key 4), and the cover screws (key 6).

## Performance

The performance characteristics shown in figure 6 illustrate several important functional parameters.

$S_L$  and  $S_H$  represent the low and high set points, respectively. The set range is 3 to 97 percent of the Bourdon tube rating. However, with a single high-low unit or a high-only/low-only pair, there is a limit on how close to each other the set points can be adjusted. This limit is defined as set point  $\Delta P_{MIN}$  and is shown as  $S_L'$  and  $S_H'$ .

Trip-to-reset is the combined effect of pilot dead band and hysteresis. After the pilot has tripped, it will

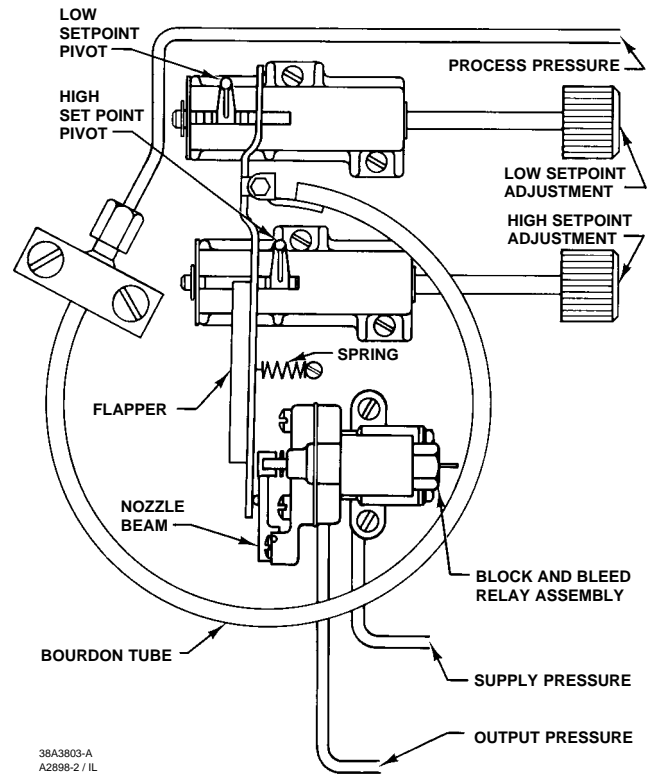

Figure 7. Principle of Operation Schematic

automatically reset when the process pressure returns to the set range. However, full output is not instantaneous. The difference between the set point and reset to full output is the trip-to-reset zone. This parameter is also a function of the Bourdon tube rating as shown in figure 6.

Finally, repeatability is the switch point deviation around the set point as a percentage of the Bourdon tube rating.

## Principle of Operation

Refer to the schematic in figure 7. The following explanation describes the principle of operation for a high-low pilot.

Process pressure is connected to the pilot Bourdon tube sensing element. As the process pressure decreases, the Bourdon tube contracts; as the process pressure increases, the Bourdon tube expands. While the process pressure remains above the low set point and below the high set point, the flapper does not contact either set point pivot, but contacts the nozzle beam. This keeps the relay nozzle capped off, maintaining full output pressure.

# 4660 Pressure Pilot

A decrease in process pressure below the low set point, or an increase in process pressure above the high set point causes the flapper to contact the respective low or high set point pivot and uncap the relay nozzle. This trips the relay assembly, which blocks supply pressure and vents (bleeds) the output pressure to zero.

When the process pressure returns to a value between the low and high set points, the flapper no longer contacts one of the set point pivots, but contacts the nozzle beam, again capping off the relay nozzle. This resets the relay assembly, restoring full output pressure.

## Maintenance

Select the appropriate maintenance procedure, and perform the numbered steps. Each procedure requires that supply pressure and process pressure be shut off before beginning maintenance. All key numbers are shown in figure 8.

### WARNING

**Avoid personal injury or property damage from an uncontrolled process or sudden release of process pressure. Before starting disassembly:**

- **Always wear protective clothing, gloves, and eyewear when performing any maintenance operations.**
- **Provide some temporary means of process control before taking the pilot out of service.**
- **Shut off the process pressure line and the supply pressure line, and bleed all of the supply pressure.**
- **Bleed all process pressure from the pilot so that no pressure is contained in the Bourdon tube.**
- **When bleeding the supply or process pressure, natural gas, if used as the supply medium, will seep from the unit into the surrounding atmosphere. Personal injury or property damage may result from fire or explosion if preventative measures are not taken, such as adequate**

**ventilation and the removal of any ignition sources.**

- **Use lock-out procedures to be sure that the above measures stay in effect while you are working on the equipment.**
- **Check with your process or safety engineer for any additional measures that must be taken to protect against process media.**

## Bourdon Tube/ Flapper Assembly Replacement

Obtain the Bourdon tube/flapper assembly kit listed in the parts kit section.

1. Remove the case cover screw (key 5) and the case cover (key 3).
2. Unhook the flapper spring (key 18) from the Bourdon tube/flapper assembly. Inspect the flapper spring, and replace it if the coils are separated when the spring is in its free state with no extension.
3. Loosen the screws (key 27), and remove the Bourdon tube/flapper assembly.
4. Disconnect the process tubing (key 8).
5. Install a new Bourdon tube/flapper assembly and tighten the machine screws.
6. Reconnect the process tubing to the Bourdon tube/flapper assembly.
7. Reconnect the flapper spring to the Bourdon tube/flapper assembly.
8. Replace the case cover, and attach it with the case cover screw.
9. If appropriate, place a new label (key 73) with the new Bourdon tube set range on the front plate (key 74).
10. Reset the high and/or low set points according to the procedures presented in the Operating Information section.
11. Refer to the alignment of the nozzle beam procedures in the Operating Information section.

## Block-and-Bleed Relay Assembly Replacement

Obtain the block-and-bleed relay assembly listed in the parts kit section.

1. Make sure supply pressure is shut off and vented.

2. Remove the case cover screw (key 5) and the case cover (key 3).
3. Remove the machine screws (key 57).
4. Remove the block-and-bleed relay assembly.
5. Make sure the O-rings are in place on the bottom flange, then install a new block-and-bleed relay assembly.
6. Tighten the machine screws.
7. Refer to the alignment of the nozzle beam procedure in the Operating Information section.
8. Replace the case cover, and attach it with the case cover screw.
9. Reset the high and/or low set points according to the procedures presented in the Operating Information section.

### Low or High Set Point Assembly Replacement

Obtain the set point assembly listed in the parts kit section, then perform one or the other of the following procedures.

#### *Pilots Without Set Point Indication*

##### Note

**New locking wedges (key 71) must be installed when performing this procedure. Refer to the parts list section and obtain the correct quantity. Two are required for low or high versions. Four are required for high-low versions.**

1. Perform steps 1 through 4 of the Bourdon tube/flapper assembly replacement procedure.
2. Remove the knob (key 67) by loosening the knob set screw and pulling it away from the front plate (key 74).
3. Remove the locking disk (key 69) and the locking nut (key 70).
4. Remove the screws (key 68) and the switch point assembly.
5. Remove the locking wedges (key 71).
6. Install the new set point assembly and tighten the screws.
7. Install new locking wedges over the set point stem.

8. Apply lubricant (key 81) to the locking nut threads and install it finger-tight.
9. Tighten the locking nut to 5.6 N•m (50 lbf•in) of torque. Back the nut out one-quarter turn.
10. Re-tighten the locking nut to 1.1 N•m (10 lbf•in) of torque.
11. Install the knob on the stem and tighten the set screws. Attempt to rotate the knob. If the knob rotates, repeat steps 9 and 10.
12. Loosen the set screws and remove the knob.
13. Repeat steps 1 through 12 if both set point assemblies are to be replaced on a high-low version of the pilot.
14. Install the front plate and the panel mounting plate (if required).
15. Install the locking disk(s) with the tab(s) as close to 90 degrees to the right of vertical as possible.
16. If the locking disk(s) cannot be installed as described in step 15, install the tab(s) between vertical and 90 degrees, rather than beyond the 90 degree position.
17. Perform steps 6 through 11 of the Bourdon tube/flapper assembly replacement procedure.

#### *Pilots With Set Point Indication*

1. Perform steps 1 through 4 of the Bourdon tube/flapper assembly replacement procedure.
2. Remove the set point indication module by loosening the set screws that attach the module to the set point assembly stem, and pulling it away from the front plate (key 74).
3. Remove the screws (key 68) and the set point assembly.
4. Install the new set point assembly and tighten the screws.
5. Repeat steps 2 through 4 if both set point assemblies are to be replaced on a high-low version of the pilot.
6. Install the front plate and the panel mounting plate (if required).
7. Align the three posts on the set point indication module(s) with the three holes on the front plate.
8. Push the set point indication module(s) flush with the front plate and tighten the set screws. Do not over-tighten the set screws.
9. Perform steps 6 through 11 of the Bourdon tube/flapper assembly replacement procedure.

# 4660 Pressure Pilot

## Parts Ordering

Whenever corresponding with your Emerson Process Management sales office about this equipment, always mention the pilot serial number located on the nameplate (key 76, figure 8) on the rear of the pilot. When ordering replacement assemblies or parts, refer to the 11-character part number of each assembly or part as found in the following parts list.



### WARNING

**Use only genuine Fisher replacement parts. Components that are not supplied by Emerson Process Management should not, under any circumstances, be used in any Fisher instrument. Use of components not supplied by Emerson Process Management will void your warranty, might adversely affect the performance of the instrument, and might jeopardize worker and workplace safety.**

### Note

**Neither Emerson, Emerson Process Management, nor any of their affiliated entities assumes responsibility for the selection, use, and maintenance of any product. Responsibility for the selection, use, and maintenance of any product remains with the purchaser and end-user.**

## Parts Kits

Description	Part Number
<b>Block-and-Bleed Relay Assembly</b>	
Block-and-Bleed Relay Replacement Assy (Includes block-and-bleed assembly and keys 53 and 57)	
Low Temperature (Fluorosilicone Elastomers)	R4660XAVR22
Standard Temperature (Nitrile Elastomers)	R4660XBBA22

Description	Part Number
-------------	-------------

### Bourdon Tube/Flapper Assembly

Bourdon Tube/Flapper Assembly (Includes Bourdon tube/flapper and keys 18, 27, 73)	
Stainless Steel Bourdon Tube	
Bourdon Tube Rating	
6.9 bar (100 psig)	R4660XBTFJ2
17.2 bar (250 psig)	R4660XBTFK2
34.5 bar (500 psig)	R4660XBTF2
69.0 bar (1000 psig)	R4660XBTFM2
103.4 bar (1500 psig)	R4660XBTFN2
172.4 bar (2500 psig)	R4660XBTFP2
344.8 bar (5000 psig)	R4660XBTFR2
517.1 bar (7500 psig)	R4660XBTF2S
N05500 Bourdon Tube (NACE MR0175-2002)	
Bourdon Tube Rating	
6.9 bar (100 psig)	R4660XBTF12
17.2 bar (250 psig)	R4660XBTF22
34.5 bar (500 psig)	R4660XBTF32
69.0 bar (1000 psig)	R4660XBTF42
103.4 bar (1500 psig)	R4660XBTF52
172.4 bar (2500 psig)	R4660XBTF62
344.8 bar (5000 psig)	R4660XBTF72
517.1 bar (7500 psig)	R4660XBTF82
689.5 bar (10,000 psig)	R4660XBTF92

### Front Cover Assembly

Front Cover Assembly (Includes keys 4, 6, 12, and 19)	R4660XFCA22
---	-------------

### Output Indicator

Output Indicator (Includes keys 13, 14, 88, 89, 90, and 91)	R4660X0PUT2
---	-------------

### Set Point Assembly

Set Point Assembly	
No Set Point (Includes keys 67, 69, 70, and 71)	R4660XSPA32
Low Set Point (Includes set point assembly and keys 67, 68, 69, 70, and 71)	R4660XSPA22
High Set Point (Includes set point assembly and keys 67, 68, 69, 70, and 71)	R4660XSPA12

### Set Point Indicator

Set Point Indicator (Includes set point assembly and adjustment key)	
High Set Point	
Bourdon Tube Rating	
6.9 bar (100 psig)	R4660XSP1A2
17.2 bar (250 psig)	R4660XSP1B2
34.5 bar (500 psig)	R4660XSP1C2
69.0 bar (1000 psig)	R4660XSP1D2
103.4 bar (1500 psig)	R4660XSP1E2
172.4 bar (2500 psig)	R4660XSP1F2
344.8 bar (5000 psig)	R4660XSP1G2
517.1 bar (7500 psig)	R4660XSP1H2
689.5 bar (10,000 psig)	R4660XSP1T2

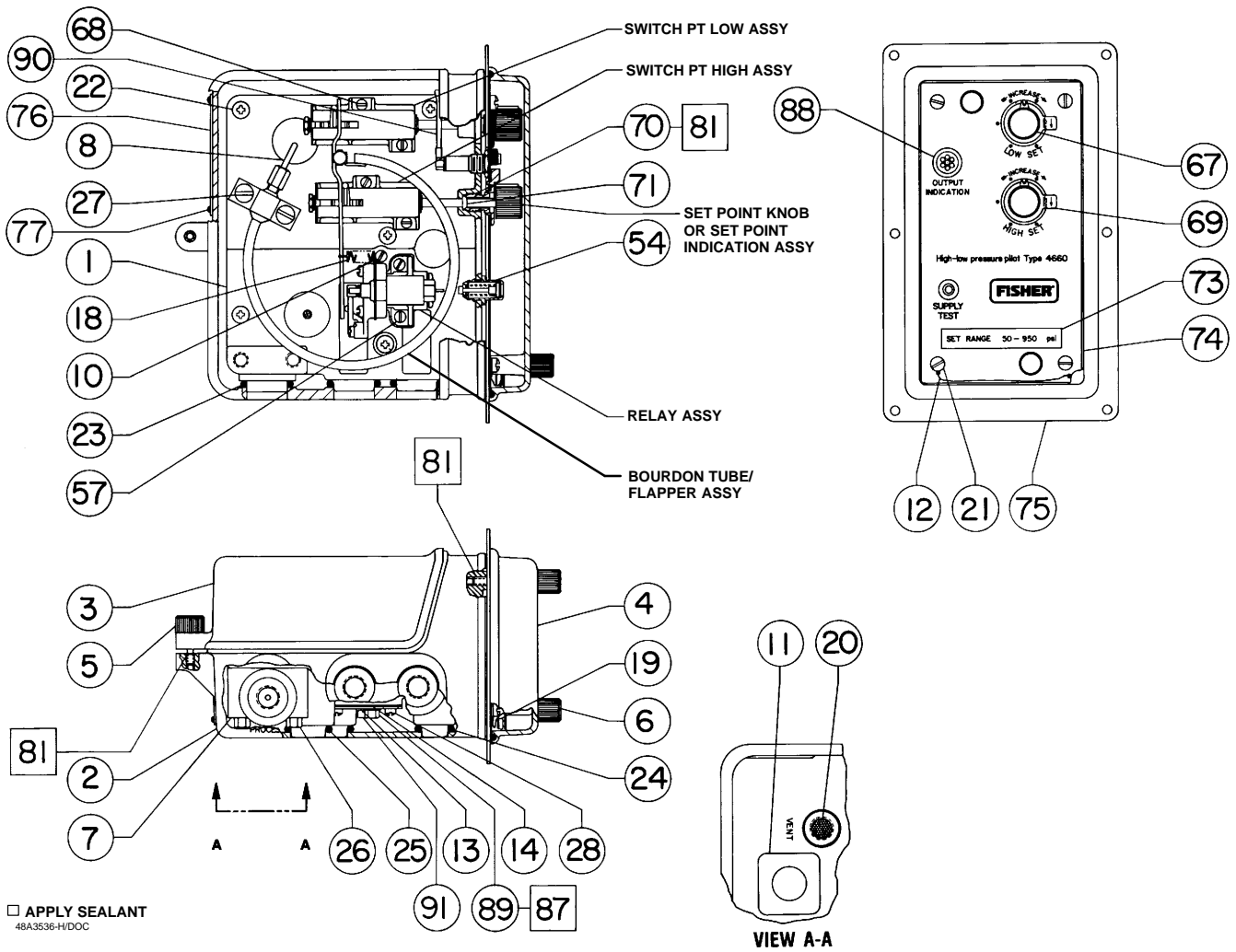

Figure 8. 4660 Pilot Assembly

Description	Part Number	Description	Part Number
<b>Set Point Indicator (continued)</b>			
Set Point Indicator (Includes set point assembly and adjustment key)			
Low Set Point			
Bourdon Tube Rating			
6.9 bar (100 psig)	R4660XSP1J2		
17.2 bar (250 psig)	R4660XSP1K2		
34.5 bar (500 psig)	R4660XSP1L2		
69.0 bar (1000 psig)	R4660XSP1M2		
103.4 bar (1500 psig)	R4660XSP1N2		
172.4 bar (2500 psig)	R4660XSP1P2		
344.8 bar (5000 psig)	R4660XSP1R2		
517.1 bar (7500 psig)	R4660XSP1S2		
689.5 bar (10,000 psig)	R4660XSP1U2		
<b>Supply Test Plunger Assembly</b>			
Supply Test Plunger Assembly			
	R4660XSTP22		
<b>Tamper-Resistant Cover</b>			
Tamper-Resistant Cover (Includes hex tool and key 6)			
	R4660XTPC12		

# 4660 Pressure Pilot

Key	Description	Part Number	Key	Description	Part Number
			23*	O-Ring, nitrile (3 req'd)	1B885506992
			24*	O-Ring, nitrile (3 req'd)	18A1088X012
			25*	O-Ring, nitrile	1D2375X0022
			26	Cap Screw, stainless steel (2 req'd) 1/4 NPT internal process connection	
			27	Machine Screw, stainless steel (2 req'd)	
			28	Machine Screw, stainless steel (3 req'd)	
			54	Cleanout Assembly	
			57	Machine Screw, stainless steel (2 req'd)	
			67	Knob (w/o set point indication) <sup>(1)</sup>	
			68	Screw, stainless steel <sup>(2)</sup>	
			69	Locking Disk, PPO (w/o set point indication) <sup>(1)</sup>	
			70	Locking Nut, aluminum/PTFE anodized (w/o set point indication) <sup>(1)</sup>	
			71	Locking Wedge, PPO (w/o set point indication) <sup>(2)</sup>	
			73	Range Label	
			74	Front Plate, stainless steel w/o Output Indication Low Set High Set High/Low Set w/ Output Indication Low Set High Set High/Low Set	
			75	Mounting Plate, stainless steel (not shown) Panel Mounting Actuator Yoke Mounting Actuator Casing Mounting Pipestand Mounting	
			76	Nameplate, stainless steel	
			77	Self-Tapping Screw, stainless steel (4 req'd)	
			81	Lubricant, Loctite <sup>®</sup> Silver Grade Anti-Seize (76759, 76764, or 76775),	
			84	Cap Screw, pl steel (not shown) Actuator Yoke Mounting (5 req'd) Actuator Casing Mounting (3 req'd) Pipestand Mounting (3 req'd)	
			85	Lock Washer, pl steel (not shown) Actuator Yoke Mounting (5 req'd) Actuator Casing & Pipestand Mounting (3 req'd)	
			86	Pipe Clamp, pl steel (not shown) Pipestand Mounting (2 req'd)	
			87	Sealant, Loctite <sup>®</sup> 222™ Low Strength Threadlocker (not furnished with pilot)	
			88	Output Indicator	
			89	Elbow Fitting, stainless steel (output indicator) (2 req'd)	
			90	Tubing, Nylon (output indicator)	
			91	Tubing, polyethylene (output indicator (2 req'd)	
			92*	Gasket, Nitrile (for panel mounting)	28A4549X012
			---	Hex Tool, alloy steel (not shown) Tamper-Resistant Cover	

## Parts List

### Note

Part numbers are shown for recommended spares only. For part numbers not shown, contact your Emerson Process Management sales office.

Key	Description	Part Number
1	Base, hard coat anodized aluminum w/duplex seal	
2	Case, polyester	
3	Case cover, polyester	
4	Cover, polyester	
5	Case Cover Screw, stainless steel/polyester	
6	Cover Screw, stainless steel/polyester (2 req'd)	
7	Process Block, 316 stainless steel 1/4 NPT internal process connection	
8	Process Tubing, stainless steel For all Bourdon Tube ranges up to 170 bar (2500 psig) For Bourdon tube ranges 350 bar (5000 psig) or over N05500 for NACE MR0175-2002 For all Bourdon Tube ranges up to 170 bar (2500 psig) For Bourdon tube ranges 350 bar (5000 psig) or over	
10	Flapper Spring Support, stainless steel	
11	Blow-Out Plug, silicone	
12	Cable Assembly, stainless steel/nylon	
13	Cover Plate, stainless steel w/o output indication w/output indication	
14*	Cover Plate Gasket, chloroprene	18A1052X012
18	Flapper Spring, stainless steel Bourdon Tube Ratings to 7 bar (100 psig) For all other Bourdon tubes	
19	Cable Screw, stainless steel	
20	Vent Screen, stainless steel	
21	Machine Screw, stainless steel (4 req'd)	
22	Self-Tapping Screw, stainless steel (5 req'd)	

\*Recommended spare parts

1. One required for high or low set point versions; two required for high/low versions.  
2. Two required for high or low set point versions; four required for high/low versions.



# 4660 Pressure Pilot

---

Fisher is a mark owned by Fisher Controls International LLC, a member of the Emerson Process Management business division of Emerson Electric Co. Emerson Process Management, Emerson, and the Emerson logo are trademarks and service marks of Emerson Electric Co. Loctite and Loctite 222 are registered trademarks of Henkel Corporation. All other marks are the property of their respective owners.

*The contents of this publication are presented for informational purposes only, and while every effort has been made to ensure their accuracy, they are not to be construed as warranties or guarantees, express or implied, regarding the products or services described herein or their use or applicability. We reserve the right to modify or improve the designs or specifications of such products at any time without notice.*

Neither Emerson, Emerson Process Management, nor any of their affiliated entities assumes responsibility for the selection, use and maintenance of any product. Responsibility for the selection, use and maintenance of any product remains with the purchaser and end-user.

**Emerson Process Management**

Marshalltown, Iowa 50158 USA

Sorocaba, 18087 Brazil

Chatham, Kent ME4 4QZ UK

Dubai, United Arab Emirates

Singapore 128461 Singapore

[www.Fisher.com](http://www.Fisher.com)