

Type 8510B edisc® Control Valve (EMA ⁽¹⁾)

Contents

Introduction	1
Scope of Manual	1
Description	3
Specifications	3
Installation	3
Maintenance	6
Packing Maintenance	7
Stopping Leakage	7
Replacing the Packing	7
Replacing the Seal Ring	10
Replacing the Disc and Shaft Assembly or the Bearings	11
Actuator Mounting	15
Parts Ordering	17
Parts Kits	17
ENVIRO-SEAL® Packing System Retrofit Kits	17
ENVIRO-SEAL Packing System Repair Kits	18
Parts List	18



Figure 1. Eccentric Disc Control Valve with Type 1052 Actuator and Type 3610J Positioner

Introduction

Scope of Manual

This instruction manual includes installation, maintenance, and parts information for 2- through 12-inch Type 8510B edisc® control valves that mate with ASME, DIN, or JIS flanges (see figures 1 and 2). Refer to separate instruction manuals for information covering the actuator and accessories.

No person may install, operate, or maintain a Type 8510B valve without first ● being fully trained and qualified in valve, actuator, and accessory installation, operation, and maintenance, and ● carefully reading and understanding the contents of this manual. If you have any questions about these instructions, contact your Emerson Process Management sales office before proceeding.



Figure 2. Type 8510B with Alternate Double D Shaft with Anti-Blowout and Type 1035 Actuator

1. Europe, Middle East, and Africa



8510B Valve (EMA)

Table 1. Specifications

Valve Body Sizes and End Connection Style

For flangeless valves that install between ASME and DIN flanges, see table 2

Maximum Inlet Pressures, Temperatures, and Pressure Drops^(1,2)

WCC Steel, CF3M Stainless Steel (316L SST), and CN7M (Alloy 20) Valve Bodies: Consistent with applicable pressure-temperature ratings per table 2 up to the maximum material temperature capabilities listed in table 3, but do not exceed the pressure, temperature, and pressure drop conditions of the valve construction. Also see the Installation section.

M35-1 Valve Bodies: Inlet pressure and temperature capabilities are shown in table 4, but do not exceed the pressure, temperature, and pressure drop conditions of the valve construction. Also see the Installation section

Shutoff Classifications

PTFE Seal Ring: Bidirectional shutoff to Class VI is standard

All-Metal Seal Ring: 0.001% of maximum valve capacity (one tenth of Class IV per ANSI/FCI 70-2 and IEC 60534-4)

Material Temperature Capabilities⁽¹⁾

See table 3

Flow Characteristic

Approximately linear

Flow Direction

Standard (forward flow) is with seal retainer (key 2, figure 9) facing upstream; reverse flow is permissible, contact your Emerson Process Management sales office with application limits

Disc Rotation

Clockwise to close (when viewed from actuator end of valve body) through 90 degrees of disc rotation

Actuator/Valve Action

With diaphragm or piston rotary actuators, they are field reversible between:

- push-down-to-open (extending actuator rod opens the valve) and
- push-down-to-close (extending actuator rod closes the valve)

With Type 1035 Rack and Pinion actuator with spring return or double acting action, field-reversible between ■ fail-to-open and ■ fail-to-close

Valve Body Classification

■ ASME face-to-face dimensions for 3 through 6-inch sizes in Class 150 and 300, and face-to-face dimensions for 8 through 12-inch sizes in Class 150 meet API 609 standard

■ Face-to-face dimensions for all sizes meet DIN 3202 part 3/K2, and

■ JIS B2210 standard face-to-face dimensions are available upon request

Mating Flange Capabilities

All sizes compatible with welding-neck and slip-on flanges (schedule 80 or lighter for 2- through 12-inch sizes)

Shaft Diameters

See table 2

Approximate Weights

See table 2

1. The pressure/temperature limits in this manual and any applicable standard or code limitation should not be exceeded.

2. The maximum allowable body inlet pressure might exceed the flange joint pressure rating. If so, actual inlet pressure must not exceed the flange joint pressure rating.

Table 2. Valve Body Size, Shaft Diameter, Approximate Weight, and ASME Rating and Flange Compatibility

VALVE SIZE, INCHES	SHAFT DIAMETER		APPROXIMATE WEIGHT		ASME RATING COMPATIBILITY—STEEL, STAINLESS STEEL, AND ALLOY 20 VALVE BODIES ⁽²⁾	VALVE BODY DESIGNATION—M35-1 ⁽¹⁾⁽²⁾	ASME FLANGE COMPATIBILITY ⁽²⁾	DIN FLANGE COMPATIBILITY ⁽³⁾
	mm	Inches	kg	Pounds				
2	12.7	1/2	4.3	9.5	Class 150, 300, & 600	Class 150, 300, & 600	Class 150, 300, & 600	PN10, PN16, & PN25 PN40, PN63, & PN100
3	15.9	5/8	5.9	13				
4	19.1	3/4	9.1	20				
6	25.4	1	19	41				
8	31.8	1-1/4	31	69				
10	31.8	1-1/4	46	102	Class 150 Class 300	150 300	Class 150 Class 300	PN10 & PN16 PN25 & PN40
12	38.1	1-1/2	72	158	Class 150 Class 300	150 300	Class 150 Class 300	PN10 & PN16 PN25 & PN40

1. M35-1 valve materials are not included in ASME B16.34 pressure/temperature ratings. See table 3 for pressure/temperature information for M35-1 valve bodies. The designations 150, 300, and 600 for these valve bodies are used only to indicate relative pressure-retaining capabilities and are not ASME pressure/temperature rating class designations.
2. The Double D end connection with anti-blowout shaft is only available in Class 150.
3. The Double D end connection with anti-blowout shaft is available only in PN10 and PN16.

Note

Neither Emerson®, Emerson Process Management, Fisher®, nor any of their affiliated entities assumes responsibility for the selection, use and maintenance of any product. Responsibility for the selection, use, and maintenance of any product remains with the purchaser and end-user.

Description

The Type 8510B flangeless control valve has an eccentrically mounted disc that self-centers in the line during installation. The valve includes built-in electrical bonding of the shaft to the valve body. This valve has either a splined shaft for use with power, handwheel, or handlever rotary actuators, or a double D end connection with anti-blowout shaft for use with Type 1035 Rack and Pinion actuators and other quarter-turn actuators. It is used for throttling or on/off control of a wide variety of liquids and gases. The Type 8510B is a balanced construction available in Class 150 through 600. Figure 9 illustrates the various constructions.

Specifications

Specifications for the Type 8510B valve body are shown in table 1.

Installation

Key numbers in this procedure are shown in figure 9 unless otherwise indicated.

 **WARNING**

Always wear protective gloves, clothing and eyewear when performing any installation operations to avoid personal injury.

To avoid personal injury or property damage resulting from the bursting of pressure retaining parts, be certain the service conditions do not exceed either the valve body rating or the flange joint rating, or other limits given in table 1 or on the nameplate. Use pressure-relieving or pressure-limiting devices to prevent the service conditions from exceeding these limits.

If installing into an existing application, also refer to the **WARNING** at the beginning of the Maintenance section in this instruction manual.

CAUTION

The valve configuration and construction materials were selected to meet particular pressure, temperature, pressure drop, and controlled fluid conditions specified in the customer's order. Because some valve body/trim material combinations are limited in their pressure drop and temperature range capabilities (especially due to differences in thermal expansion rates), do not apply any other conditions to the valve without first contacting your Emerson Process Management sales office.

Table 3. Material Temperature Capabilities

MATERIAL						TEMPERATURE CAPABILITY			
Valve Body	Disc	Shaft	Bearing Lining and Jacket	Seal	Packing ⁽⁴⁾	°C	°F		
WCC steel	WCC steel with chrome-plated seating surface, or S31603 (316L SST)	S17400 (17-4PH)	PTFE ⁽²⁾ /Composition lined with S31603 (316L SST) jacket	PTFE Composition or S31600 (316 SST)	All	-29 to 232 ⁽¹⁾	-20 to 450 ⁽¹⁾		
			S44004 (440-C SST) All metal bearing	S31600	PTFE V-ring or PTFE/Combustion	-29 to 232	-20 to 450		
			PTFE ⁽²⁾ /Composition lined with S31603 (316L SST) jacket	S31600	Graphite ribbon	-29 to 427	-20 to 800		
CF3M (316L stainless steel)	S31603 (316L SST) with chrome-plated surface or S31603 (316L SST) without plating with PTFE seat only)	S17400 ⁽⁵⁾	PTFE ⁽²⁾ /Composition lined with S31603 (316L SST) jacket	PTFE Composition	PTFE V-ring	-40 to 232 ⁽¹⁾	-40 to 450 ⁽¹⁾		
			Filled PTFE ⁽³⁾ lined with S31603 (316L SST) jacket	S31600	PTFE/Composition or graphite ribbon	-46 to 232 ⁽¹⁾	-50 to 450 ⁽¹⁾		
			PTFE ⁽²⁾ /Composition lined with S31603 (316L SST) jacket	PTFE Composition	PTFE V-ring	-40 to 232	-40 to 450		
		S20910	Silver plated alloy 6B (CoCr-A)	S31600	PTFE/Composition	Graphite ribbon	-46 to 260	-50 to 500	
			Alloy 6B	S31600	PTFE V-ring	PTFE/Composition or graphite ribbon	-46 to 427	-50 to 800	
					PTFE V-ring	PTFE/Composition or graphite ribbon	-40 to 232 ⁽¹⁾	-40 to 450 ⁽¹⁾	
					PTFE/Composition	Graphite ribbon	-46 to 232 ⁽¹⁾	-50 to 450 ⁽¹⁾	
		M35-1 ⁽⁵⁾	M35-1	N05500 ⁽⁵⁾	Filled PTFE ⁽³⁾ with N04400 jacket	PTFE Composition	PTFE V-ring	-40 to 232 ⁽¹⁾	-40 to 450 ⁽¹⁾
							PTFE/Composition or graphite ribbon	-46 to 232 ⁽¹⁾	-50 to 450 ⁽¹⁾
							PTFE V-ring	-40 to 232	-40 to 450
CN7M ⁽⁵⁾ (alloy 20)	CN7M (alloy 20)	N08020 ⁽⁵⁾ (alloy 20)	Filled PTFE ⁽³⁾ with N08020 jacket	PTFE Composition	PTFE V-ring	-40 to 149	-40 to 300		
					PTFE/Composition or graphite ribbon	-46 to 149	-50 to 300		

1. For hot water or steam service, limit maximum temperature to 207°C (405°F).
 2. Reinforced PTFE in phenolic resin. Emerson Process Management designation is FMS 30B4.
 3. PTFE with selected fillers. Emerson Process Management designation is FMS 30B5.
 4. For temperature limits of ENVIRO-SEAL packing systems, see the instruction manual ENVIRO-SEAL® Packing System for V-Ball®, ēdisc® and ēplug® Rotary Valves (Form 5305).
 5. These materials are only available in the splined shaft version of Type 8510B, and not in the double D end connection with anti-blowout shaft.

Table 4. Maximum Allowable Inlet Pressure for M35-1 Valves⁽¹⁾

TEMPERATURE	M35-1 ⁽¹⁾		
	150 ⁽²⁾	300 ⁽²⁾	600 ⁽²⁾
°C	Bar		
-46 to 38	15.8	41.3	82.7
93	13.8	36.5	72.7
149	13.1	34.1	68.2
204	12.7	33.1	65.8
232	12.7	33.1	65.8
°F	Psig		
-50 to 100	230	600	1200
200	200	530	1050
300	190	495	990
400	185	480	955
450	185	480	955

1. This material is not listed in ASME B16.34. Also see the Installation section.
 2. The designations 150, 300, and 600 are used only to indicate relative pressure-retaining capabilities and are not ASME pressure-temperature rating class designations.

The maximum allowable inlet pressures for steel, stainless steel, and alloy 20 valve bodies are consistent with the pressure-temperature ratings shown in table 2, except where further limited by the trim and packing material temperature capabilities given in table 3. Valves are also available in M35-1 valve body material that is not listed in ASME B16.34. Valve bodies constructed of this material mate with ASME flanges but are not included in ASME pressure-temperature ratings and must **not** be installed in systems requiring conformance to ASME standards. Maximum allowable inlet pressures for Type 8510B valve bodies made of M35-1 construction materials are shown in table 4.

1. Install a three-valve bypass around the control valve assembly if continuous operation is necessary during inspection and maintenance of the valve body.

2. Inspect the valve body to be certain that it is free of foreign material.
3. The valve is normally shipped as part of a control valve assembly, with a power or manual actuator mounted on the valve body.

If the valve body and actuator have been purchased separately or if the actuator has been removed for maintenance, mount the actuator, and adjust actuator travel before inserting the valve body into the line. This is necessary due to the measurements that must be made during the actuator adjustment process. Refer to the Actuator Mounting section of this manual and to the separate actuator instruction manual for mounting and adjusting instructions before proceeding.

4. Be certain that adjacent pipelines are free of any foreign material, such as pipe scale or welding slag, that could damage the valve body seating surfaces.

CAUTION

Damage to the disc (key 3) will occur if any pipe flanges or piping connected to the valve body interfere with the disc rotation path. However, the disc can be rotated without interference when the valve body is installed between adjacent pipe flanges or piping that has an inside diameter equal to or greater than either schedule 80 pipe or compatible DIN or JIS pipe sizes. If piping with a smaller inner diameter than specified above is connected to the valve, measure carefully to be certain the disc rotates without interference before putting the valve into operation.

5. Flow is in the standard direction when the seal retainer (key 2) is facing upstream. Standard flow direction is also indicated by the flow direction arrow cast into the valve body. Flow in the reverse direction is permissible.

CAUTION

Rotating the disc (key 3) past either the open or closed position could damage the seal and disc sealing surfaces and could cause the disc to jam in the valve body bore. The disc stop should be zeroed in its flat

position as shown in figure 8. Do not use the disc stop as a travel stop for the actuator. Use the actuator travel stop provisions.

6. With the disc in the closed position, install line flange gaskets, and insert the valve between the pipeline flanges. Use either flat sheet gaskets or spiral-wound gaskets with compression-controlling centering rings. Spiral-wound gaskets without compression-controlling centering rings are not recommended for this purpose. Composition gaskets may be used to 343°C (650°F), and the optional FGM gaskets (key 29, not shown) may be used for -129 to 538°C (-200 to 1000°F) temperatures.
7. There are four flange bolt holes in the valve body (key 1), and each hole engages one corresponding line flange stud. Insert the valve between the flanges and install the four line flange studs to roughly center the valve body in the pipeline.
8. After centering the valve body, first lubricate and then install the remaining line flange studs to secure the valve in the pipeline. Tighten the nuts to the line flange studs in a crisscross sequence to ensure proper alignment of the valve body with the flanges.

WARNING

A Type 8510B valve body is not necessarily grounded when installed in a pipeline. If the valve is used in a flammable or hazardous atmosphere or for oxygen service, an explosion could result due to a discharge of static electricity from the valve components. To avoid personal injury or property damage, always make sure that the valve body is grounded to the pipeline before putting the control valve assembly into operation in a flammable or hazardous atmosphere.

Note

Standard Type 8510B packings are composed of all conductive packing rings (graphite ribbon packing) or partially conductive packing rings (such as a carbon-filled PTFE female adaptor with PTFE V-ring packing or a graphite composition packing ring with PTFE/composition packing) to electrically bond the shaft to the valve body for hazardous area service. For oxygen service applications, provide

8510B Valve (EMA)

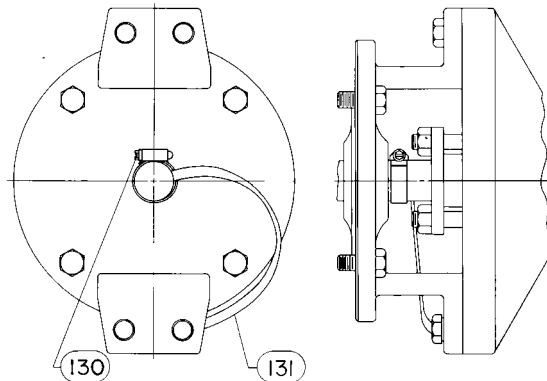

Figure 3. Optional Shaft-to-Valve Body Bonding Strap Assembly

alternate shaft-to-valve body bonding according to the following step.

9. For oxygen service applications, attach the bonding strap assembly (key 131, figure 3) to the shaft with the clamp (key 130, figure 3), and connect the other end of the bonding strap assembly to the valve body with the cap screw (key 22). Secure each cap screw with a hex nut (key 30).

WARNING

Personal injury could result from packing leakage. Valve packing was tightened prior to shipment; however, the packing might require some readjustment to meet specific service conditions.

Valves with ENVIRO-SEAL packing systems will not require this initial re-adjustment. See ENVIRO-SEAL Packing System for Rotary Valves Instruction Manual (Form 5305) for packing instructions. If you wish to convert your present packing arrangement to ENVIRO-SEAL packing, refer to the retrofit kits listed in the parts kit sub-section near the end of this manual.

Maintenance

Valve body parts are subject to normal wear and must be inspected regularly and replaced as necessary. The frequency of inspection and replacement depends upon the severity of service conditions. Instructions are given in this section for:

replacing packing; replacing disc, shaft, or bearing(s); changing disc rotation or valve action; and mounting and adjusting the actuator.

As used in these instructions, actuator refers to power actuators (such as pneumatic diaphragm, piston actuators, and rack and pinion actuators) or manual actuators (such as handwheel or handlever actuators).

WARNING

Avoid personal injury and property damage from sudden release of process pressure or bursting of parts. Before performing any maintenance operations:

- Always wear protective gloves, clothing, and eyewear when performing any maintenance operations.
- Disconnect any operating lines providing air pressure, electric power, or a control signal to the actuator. Be sure the actuator cannot suddenly open or close the valve.
- Use bypass valves or completely shut off the process to isolate the valve from process pressure. Relieve process pressure on both sides of the valve. Drain the process media from both sides of the valve.
- Vent the power actuator loading pressure and relieve any spring precompression.
- Use lock-out procedures to be sure that the above measures stay in effect while you work on the equipment.
- The valve packing box may contain process fluids that are pressurized, even when the valve has been removed from the pipeline. Process fluids may spray out from under pressure when removing the packing hardware or packing rings, or when loosening the packing box pipe plug.
- Check with your process or safety engineer for any additional measures that must be taken to protect against process media.

Packing Maintenance

Key numbers are referenced in figure 4 unless otherwise indicated. All maintenance operations in this section may be performed with the valve in the line. Packing may be PTFE V-ring or graphite.

An ENVIRO-SEAL packing system is also available with the Type 8510B control valve. To install the ENVIRO-SEAL packing system in an existing valve, follow the instructions in the instruction manual included with the packing system (Form 5305). To remove packing parts in a valve with the ENVIRO-SEAL packing system, follow the procedures for valves with the ENVIRO-SEAL packing system in this section. Install the replacement packing following the instructions in the packing system instruction manual (Form 5305).

Stopping Leakage

For valves with PTFE or graphite packing:

CAUTION

Tighten the packing flange only enough to prevent shaft leakage. Excessive tightening will only accelerate wear of the packing and could produce higher torques on the valve.

Leakage around the packing followers can be stopped by tightening the packing flange nuts (key 12, figure 9).

If the packing is relatively new and tight on the shaft, and if tightening the packing flange nuts does not stop leakage, the shaft may be worn or nicked so that a seal cannot be made. If the leakage comes from the outside diameter of the packing, the leakage may be caused by nicks or scratches around the packing box wall. Inspect the shaft and packing box wall for nicks and scratches when performing the packing replacement procedures.

For valves with the ENVIRO-SEAL packing system:

Optimum performance of the ENVIRO-SEAL packing system is obtained when the Belleville springs are tightened to their "target load." The target load is the point where the springs are compressed to 85% of their maximum deflection, or

nearly flat. Maximum deflection is when the springs are 100% compressed, or completely flat.

Under normal conditions, the packing nuts should not require re-tightening. However, when servicing, if the springs do not remain at the target load of 85% compression, retighten the packing box nuts according to the following procedure:

1. Tighten the packing flange nuts alternately and evenly, keeping the packing flange parallel with the valve flange (see figure 4), until the Belleville springs are compressed 100% (or completely flat).

- **For PTFE packing**, loosen each packing flange nut one half turn (180° of rotation).
- **For Graphite packing**, loosen each packing flange nut one quarter turn (90° of rotation).

The target load of 85% compression has now been reached. If leakage continues, replace the packing components as described in the following procedures.

Replacing the Packing

For valves with PTFE or graphite packing:

This procedure may be performed without removing the actuator from the valve body if adding split PTFE/composition packing rings as a temporary measure on the actuator side of the valve body. However, the actuator must be removed from the valve body if replacing any other kind of packing on the actuator side of the valve body.

Key numbers in this procedure are shown in figure 9 unless otherwise indicated.

1. Isolate the control valve from the line pressure, release pressure from both sides of the valve body, and drain the process media from both sides of the valve. If using a power actuator, also shutoff all pressure lines to the power actuator, release all pressure from the actuator. Use lock-out procedures to be sure that the above measures stay in effect while you work on the equipment.

2. Remove the packing flange nuts (key 12) and packing follower (key 15), plus the packing flange (key 9) if used, from the side of the valve body opposite the actuator.

CAUTION

If removing the actuator in the following step, use a wheel puller to

8510B Valve (EMA)

separate the actuator parts from the valve shaft. Do not drive the actuator parts off the valve shaft because this could move the valve bearings and disc away from the centered position, thereby damaging the disc and the valve body.

3. If necessary to remove the actuator, remove the cap screws and nuts (keys 22 and 30). Remove the clamp (key 130, figure 3) if the strap (key 131, figure 3) is used. If necessary, refer to separate actuator instruction manuals for assistance in removing the actuator.
4. Remove the packing flange nuts and pull out the packing follower (key 16), plus the packing flange (key 10) if used, from the actuator side of the valve body.
5. Remove the old packing rings (key 13) and, if used, the packing washers (key 27). Carefully avoid scratching the shaft or packing box wall to avoid damage that could cause leakage around the shaft. Clean all accessible metal parts and surfaces to remove particles that would prevent the packing from sealing.

Note

Except with oxygen service, lightly lubricate new PTFE V-rings with phenylmethyl silicone lubricant to aid in assembly.



WARNING

Do not lubricate parts when used in oxygen service, or where the lubrication is incompatible with the process media. Any use of lubricant can lead to the sudden explosion of media due to the oil/oxygen mixture, causing personal injury or property damage.

6. Use the appropriate procedures below for installing packing in either end of the valve.
 - Install the packing washers (key 14), and packing rings (key 13). Make sure that PTFE/composition packing rings are installed so that the ring splits do not line up to form a leak path.
 - With graphite ribbon packing, stack the packing rings and packing washers together as shown in figure 3, and slide the stack into the packing box as

far as it will go while carefully avoiding trapping air among the rings.

- Install both packing followers and, if used, the packing flanges.
- Install the packing flange nuts, and tighten them only far enough to stop leakage under normal operating conditions. For oxygen service applications, perform the next step.
- For oxygen service applications, attach the bonding strap assembly (key 131, figure 3) to the shaft with the clamp (key 130, figure 3), and connect the other end of the bonding strap assembly to the valve body with a cap screw (key 22). Secure each cap screw with a hex nut (key 30).

7. Mount the actuator, if it was removed from the valve body, and adjust the actuator travel before returning the valve to service. This is necessary due to the measurements that must be made during the actuator adjustment process.

Refer to the Actuator Mounting section of this manual or to the separate actuator instruction manual for mounting and adjusting instructions before proceeding.

8. When placing the control valve into operation, check around the packing follower or leakage; retighten the packing flange nuts as required according to accepted bolting procedures.

For valves with ENVIRO-SEAL packing systems:

To replace the packing at the actuator side of the valve, the actuator must be removed. Also, the valve should be removed from the pipeline to allow proper readjustment of the disc position.

CAUTION

If removing the actuator, use a wheel puller to separate the actuator parts from the valve shaft. Do not drive the actuator parts off the valve shaft because this could move the valve bearings and disc away from the centered position, thereby damaging the disc and the valve body.

1. Isolate the control valve, and shut off all pressure lines to the power actuator. Release pressure from the valve body and actuator, and disconnect the pressure lines from the actuator if it will be removed from the valve body.

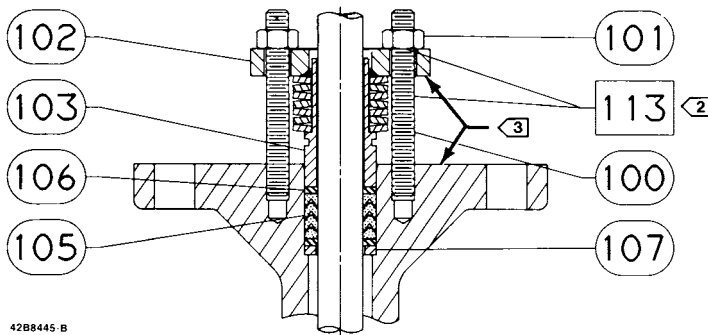
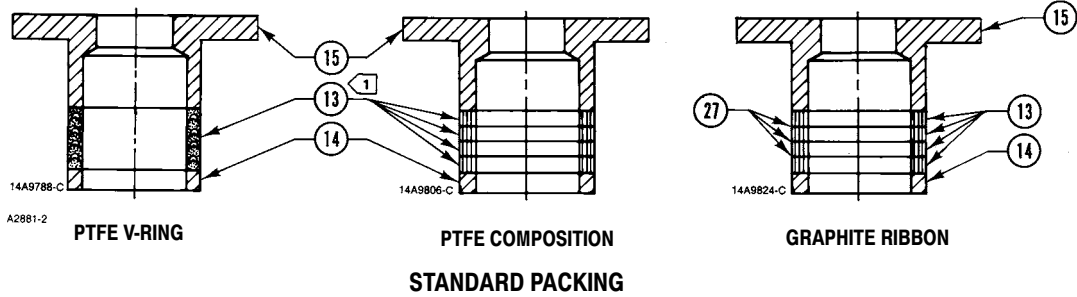

SINGLE PTFE PACKING FOR ACTUATOR END

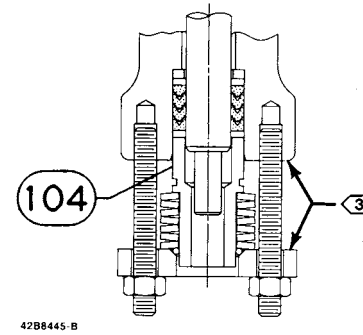

SINGLE PTFE PACKING FOR OUTBOARD END

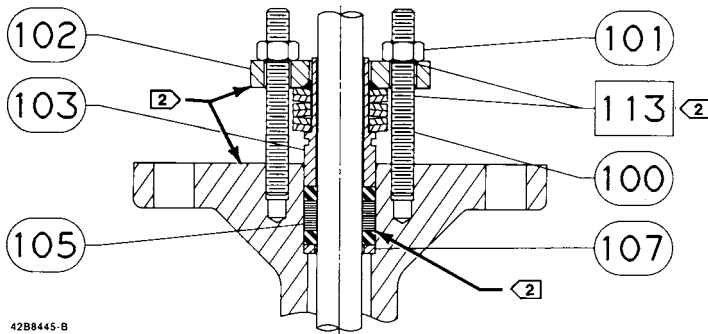

GRAPHITE PACKING FOR ACTUATOR END

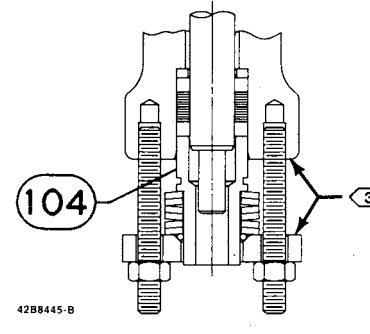

GRAPHITE PACKING FOR OUTBOARD END

ENVIRO-SEAL PACKING

NOTES:

① WITH CONDUCTIVE PACKING, THE FEMALE ADAPTOR IN PTFE V-RING PACKING IS CARBON-FILLED PTFE AND THE TOP RING IN COMPOSITION PACKING IS GRAPHITE/N06600.

② APPLY LUBRICANT.

③ THESE TWO SURFACES SHOULD REMAIN PARALLEL AS YOU ALTERNATELY AND EVENLY TIGHTEN THE PACKING NUTS (KEY 101).

Figure 4. Packing Arrangement Details

8510B Valve (EMA)

- Loosen the two packing hex nuts evenly to remove spring tension, then remove the nuts.
- Remove the packing flange and spring pack assembly. The spring pack assembly consists of the spring stack and packing follower. The spring stack is retained on the packing follower by an O-ring. Remove the anti-extrusion washer, the packing set, and the packing ring.

CAUTION

The valve shaft surface condition is critical in making and maintaining a good seal. If the valve shaft surface is scratched, nicked, dented, or worn, replace the valve shaft before replacing the packing system.

- Inspect the existing valve shaft. If necessary, replace the valve shaft as described in the procedures in this section.
- Install the new packing system components as described in the ENVIRO-SEAL Packing System for Rotary Valves Instruction Manual (Form 5305).
- Mount the actuator, if it was removed from the valve body, and adjust the actuator travel before returning the valve to service. This is necessary due to the measurements that must be made during the actuator adjustment process.

Refer to the Actuator Mounting section of this manual or to the separate actuator instruction manual for mounting and adjusting instructions.

Replacing the Seal Ring

Perform this procedure only if the control valve is not shutting off properly (that is, leaking downstream). This procedure does not require removing the actuator from the valve body.

Key numbers in this procedure are shown in figure 9 unless otherwise indicated.

- Isolate the control valve from line pressure, and relieve pressure from the valve body. Shut off and disconnect all lines from the power actuator.

WARNING

The edges of a rotating disc have a shearing effect that may result in personal injury. To help prevent such injury, stay clear of the disc edges when rotating the disc (key 3).

CAUTION

Damage to the disc (key 3) may occur if the disc is not closed when the valve is being removed from the pipeline. If necessary, apply operating pressure to the actuator temporarily to retain the disc in the closed position while removing the valve from the pipeline.

- Unscrew the flange bolts, and remove the valve from the pipeline.
- Unscrew the machine screws (key 8), and remove the seal retainer (key 2) and the retainer clip (key 34).
- Remove the seal ring or seal ring assembly (key 4). The spring (key 5) is removed with a PTFE seal ring.
- For metal seal ring assemblies, replace the gaskets (key 4C) if the entire seal ring assembly is not replaced. Scrape off the old gaskets from both sides of the seal ring and the seal ring sides of the valve body (key 1) and seal retainer. Clean the gasket surfaces.
- Reconnect or mount the actuator (if it was removed) before proceeding.

For an actuator with adjustable travel, also adjust the actuator before proceeding. This is necessary due to the measurements that must be made during the actuator adjustment process.

Refer to the Actuator Mounting section of this manual and to the separate actuator instruction manual for mounting and adjusting instructions.

- The valve should be closed during seal ring installation to permit accurate centering of the seal. To install the new seal ring:
 - For a PTFE seal, if the spring (key 5) was disassembled, hook the spring ends together. Work the spring into the recess in the seal ring (key 4). Install the seal ring and spring assembly into the recess in the valve body as shown in figure 9.

- For the metal seal ring assembly, install the seal ring assembly (key 4) as shown in figure 9.

CAUTION

New seal ring gaskets (key 4C) are very fragile and must be handled very carefully to avoid gasket kinking, cracking, or breakage that can cause leakage between the seal ring, seal retainer, and valve body. To avoid gasket damage, make sure that the valve body is lying flat so that the gaskets do not shift before the following step and step 8 are completed.

- For a metal seal ring on which the gaskets will be replaced, lay the following parts down in order so that they are accurately centered on the valve body: one new gasket; the seal ring oriented as shown in figure 9, and the second new gasket.

8. Attach the seal retainer (key 2) and the retainer clips (key 34) to the valve body and secure with the machine screws (key 8). Tighten the machine screws evenly so as not to crack or break the metal seal gaskets.

9. Be certain the disc is closed before installing the valve according to the Installation section of this instruction manual.

Replacing the Disc and Shaft Assembly or the Bearings

Perform this procedure to replace the valve disc, shaft, and taper key assembly if the disc does not rotate in response to rotation of the actuator end of the valve shaft. Key numbers in this procedure are shown in figure 9 unless otherwise indicated.

Disassembly

1. Remove the seal ring according to steps 1 through 5 of the Replacing Seal Ring section.

CAUTION

Use a wheel puller to separate actuator parts from the valve shaft. Driving the

parts off the valve shaft could move the valve bearings and disc away from the centered position, damaging the disc and valve body.

2. Remove the cap screws (key 22) and hex nuts (key 30). Remove the clamp (key 130, figure 3) if the strap (key 131, figure 3) is used. Remove the actuator from the valve body (key 1) while referring to the separate actuator instruction manual for assistance.

3. Rotate the disc (key 3) to the fully open position.

4. Refer to figure 9 and determine the location of the smaller end of the taper key (key 21). Drive out the taper key towards the larger end.

5. Unscrew and remove the packing flange nuts (key 12), packing followers (keys 15 and 16), and packing flanges (keys 9 and 10) if used, from both sides of the valve body.

WARNING

Once the shaft has been removed in the following step, the disc may fall from the valve body. To avoid personal injury and disc damage, support the disc to prevent it from falling as the shaft is being removed.

6. Pull the shaft out through the actuator side of the valve body. If the shaft cannot be pulled free, carefully use a pin punch to drive the shaft out from the side opposite the actuator. Do not damage the end of the shaft with the punch.

7. Remove the disc and spacers (key 7) from the valve body.

8. Remove the packing rings (key 13, figure 4), the packing washers (key 27, figure 4) if used, and the packing box rings (key 14, figure 4) from both sides of the valve body.

9. If either of the bearings (key 6) require maintenance or replacement, press them out, or remove them using a bearing puller. (See figure 5 for the puller dimensions.) For constructions with a metal bearing, also remove the bearing stop (key 25) with the bearing.

10. Clean the packing boxes and metal packing box parts.

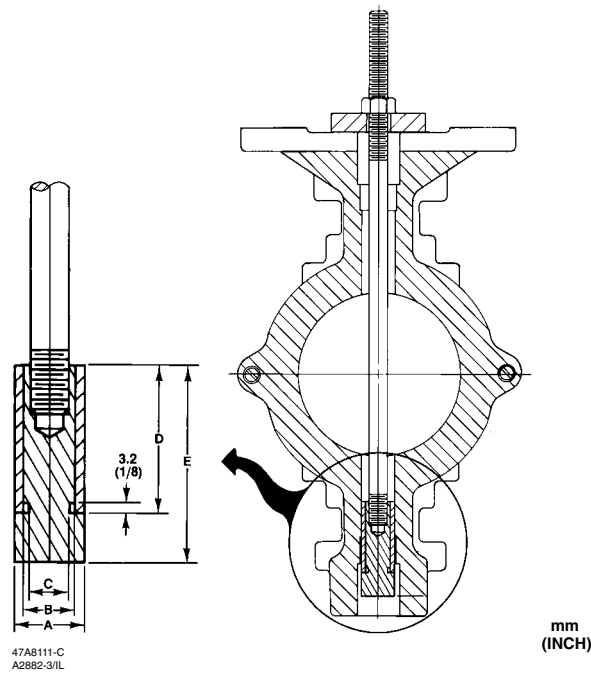

Puller Dimensions for Bearing Stop⁽¹⁾

Valve Size, In.	A		B		C		D		E	
	mm	Inch	mm	Inch	mm	Inch	mm	Inch	mm	Inch
2	15.49	0.610	13.56	0.534	10.31	0.406	14.29	0.563	33.34	1.313
	15.37	0.605	13.44	0.529						
3	18.67	0.735	16.74	0.659	13.49	0.531	15.88	0.625	34.93	1.375
	18.54	0.730	16.61	0.654						
4	22.71	0.894	19.91	0.784	16.66	0.656	22.23	0.875	41.28	1.625
	22.58	0.889	19.79	0.779						
6	29.06	1.144	26.26	1.034	23.01	0.906	28.58	1.125	47.63	1.875
	28.93	1.139	26.14	1.029						
8 & 10	35.41	1.394	32.61	1.284	29.36	1.156	34.93	1.375	53.98	2.125
	35.28	1.389	32.49	1.279						
12	41.76	1.644	38.96	1.534	35.71	1.406	41.28	1.625	60.33	2.375

1. Tolerance for the A & B dimensions are indicated by showing maximum and minimum dimensions.

Figure 5. Bearing Puller Dimensions (continued on next page)

Puller Dimensions for PTFE Bearings⁽¹⁾

Valve Size, Inch	A		B		C		D		E	
	mm	Inch	mm	Inch	mm	Inch	mm	Inch	mm	Inch
2	15.49	0.610	12.65	0.498	9.53	0.375	33.24	1.313	50.80	2.000
	15.37	0.605	12.52	0.493						
3	18.67	0.735	15.82	0.623	12.70	0.500	39.70	1.563	58.74	2.313
	18.54	0.730	15.70	0.618						
4	22.71	0.894	19.00	0.748	15.88	0.625	47.63	1.875	66.68	2.625
	22.58	0.889	18.87	0.743						
6	29.06	1.144	25.35	0.998	22.23	0.875	60.33	2.375	79.38	3.125
	28.93	1.139	25.22	0.993						
8 & 10	35.41	1.394	31.70	1.248	28.58	1.125	73.03	2.875	92.08	3.625
	35.28	1.389	31.57	1.243						
12	41.76	1.644	38.05	1.498	34.93	1.375	85.73	3.375	104.8	4.125

1. Tolerance for the A & B dimensions are indicated by showing maximum and minimum dimensions.

Puller Dimensions for Metal Bearings⁽¹⁾

Valve Size, Inch	A		B		C		D		E	
	mm	Inch	mm	Inch	mm	Inch	mm	Inch	mm	Inch
2	15.49	0.610	12.70	0.500	9.53	0.375	15.88	0.625	34.93	1.375
	15.37	0.605	12.57	0.495						
3	18.67	0.735	15.88	0.625	12.70	0.500	20.64	0.813	39.69	1.563
	18.54	0.730	15.72	0.619						
4	22.71	0.894	19.05	0.750	15.88	0.625	22.23	0.875	41.28	1.625
	22.58	0.889	18.92	0.745						
6	29.06	1.144	25.40	1.000	22.23	0.875	28.58	1.125	47.63	1.875
	28.93	1.139	25.27	.995						
8 & 10	35.41	1.394	31.75	1.250	28.58	1.125	34.93	1.375	53.98	2.125
	35.28	1.389	31.62	1.245						
12	41.76	1.644	38.10	1.500	34.93	1.375	41.28	1.625	60.33	2.375

1. Tolerance for the A & B dimensions are indicated by showing maximum and minimum dimensions.

Figure 5. Bearing Puller Dimensions (continued)

Assembly

Note

Before performing the following step, lubricate the outer bearing surfaces--except on oxygen service--with dry-film lubricant to facilitate future removal. Do not lubricate the insides of PTFE-lined bearings.

1. If new bearings and, if used, bearing stops (key 25) are required, insert them through the packing boxes. Press the bearings in until the bearing end is flush with the valve body bore at one point and the remainder of the bearing end protrudes into the valve body bore. Or, use a bearing puller (see figure 5 for puller dimensions) to properly install and locate the new bearings and the bearing stops.
2. Install spacers (key 7) into the disc (key 3). The spacers fit loosely in the disc.

Note

If contaminating the process fluid with grease is a concern, do not apply grease according to the following step; especially if the thorough cleaning in step 7 cannot be performed.

3. Apply a small amount of heavy grease to the spacers. The grease will help to hold the spacers in place during the subsequent centering procedure.



WARNING

Do not lubricate bearings that will be used for oxygen service, or where the lubrication is incompatible with the process media. Any use of lubricant can lead to the sudden explosion of media due to the oil/oxygen mixture, causing personal injury or property damage.

8510B Valve (EMA)

VALVE BODY SIZE, INCHES	SPACER TO BEARING CLEARANCE			
	Minimum		Maximum	
	mm	Inches	mm	Inches
2,3, & 4	0.102	0.004	0.229	0.009
6	0.152	0.006	0.279	0.011
8	0.203	0.008	0.330	0.013
10	0.254	0.010	0.381	0.015
12	0.305	0.012	0.432	0.017

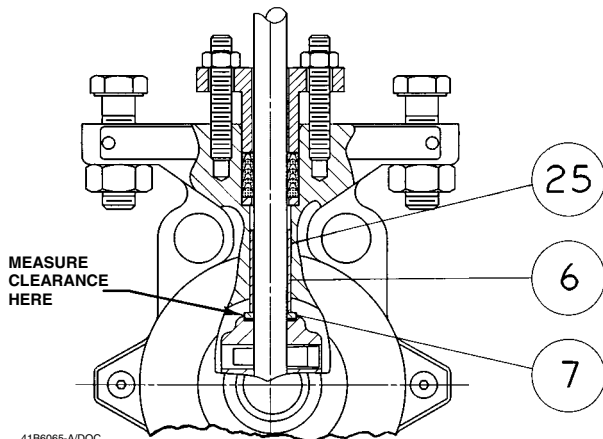

Figure 6. Spacer-Bearing Clearance (Metal Bearing Assembly Shown)

- Valves with PTFE bearings use one PTFE coated spacer on each side of the disc. Install the spacer with the PTFE side against the disc.

- Valves with metal bearings use two metal spacers on each side of the disc.

4. Insert the disc into the valve body. Be certain the taper key hole in the disc is on the actuator side of the valve body.

5. Slide the shaft through the valve body and disc.

6. Rotate the disc to the closed position. Measuring carefully, center the disc in the valve body bore. With the disc centered, use a feeler gauge to measure the clearance between each spacer and bearing. The clearance between each spacer and bearing should be equal and should be as close as possible to the value given in figure 6. If necessary, remove the disc and shaft, and reposition the bearings. Reinstall the disc and shaft, and repeat the centering and measuring process.

7. If the grease used to hold the spacers will contaminate the process fluid, disassemble the shaft and disc, remove the spacers, and clean the shaft, disc, valve body bore, and spacers thoroughly. Reinstall the disc and spacers into the valve body. Insert the shaft into the valve body and through the disc.

Table 5. Recommended Bolt Torques for Actuator-Mounting Cap Screws

VALVE SIZE, INCHES	RECOMMENDED TORQUE	RECOMMENDED TORQUE
	N•m	lbf•in.
2, 3, 4, and 6	87.7	60
8, 10, and 12	135	100

8. Slide the shaft all the way into the valve body.

9. Temporarily install the packing follower (key 16) or, if used, the packing flange (key 9). With the disc fully open, rotate the shaft until the hole in the disc (key 3) aligns with the slot in the shaft. Insert the taper key (key 21), small end first, into the taper key hole. Do not drive in the taper key. Remove the packing follower or flange.

- Current standard construction materials require the taper key (key 21) to be tack welded in place **after properly seating**.

Note

Make sure the drive shaft (key 20) is free of oil or grease, otherwise the taper key will not seat properly.

Failure to properly set the taper key could result in it coming loose while in service.

10. Insert a packing box ring (key 14) into each packing box.

11. Install the packing according to the appropriate instructions presented in steps 5 through 8 of the Replacing Packing section.

12. Drive in the taper key until solid contact is felt, then:

a. Drive the taper key in farther as follows:

Valve Body Size, Inches	Minimum Allowable Depth to Drive Taper Key after Initial Solid Contact, mm (Inches)
2	3.2 (0.125)
3, 4, 6	4.8 (0.188)
8, 10, 12	5.7 (0.219)

b. The disc, shaft and taper key assembly must be inspected to verify that the taper key spans the entire shaft flat width. If not, the taper key must be driven in farther until this condition is satisfied. However, the following depth limits must not be exceeded:

Valve Body Size, Inches	Maximum Allowable Depth to Drive Taper Key after Initial Solid Contact, mm (Inches)
2	5.6 (0.219)
3 & 4	7.1 (0.281)
6	7.9 (0.312)
8 & 10	9.5 (0.375)
12	10.3 (0.406)

13. When the above conditions are met, tack weld the taper key (key 21) to the valve disc (key 3). Use a :

- 1/8 inch diameter weld on 2- through 6-inch valves,
- 3/16 inch diameter weld on 8- through 10-inch valves, and
- 1/4 inch diameter weld on 12-inch valves.

14. Rotate the disc to the closed position.

15. Refer to the Replacing Seal Ring and Packing Maintenance procedures in this section.

Actuator Mounting

With the valve body out of the line, mount the actuator on the valve body in accordance with the instructions in the actuator instruction manual. Mount the actuator yoke to the valve body, and tighten the actuator-mounting cap screws and nuts (keys 22 and 30) to the appropriate torque from table 5. The valve body might have an optional disc stop. Do not use the disc stop as a travel stop; use the actuator travel stop (if necessary, refer to the actuator instruction manual).

Key numbers in this procedure are shown in figure 9 unless otherwise indicated.

1. If using a power actuator, determine the actuator mounting style and position from figure 7.

If using a manual handwheel or handlever actuator, refer to the appropriate actuator instruction manual for mounting positions.

CAUTION

Rotating the disc (key 3) in the wrong direction will damage the seal ring (key 4). To avoid such damage, remove the seal ring according to the following step before mounting the actuator.

2. Mark the orientation of the seal ring with respect to the valve body so that the seal can be reinstalled

in its original position. Remove the seal ring according to the procedure in the Replacing Seal Ring section of this instruction manual.

CAUTION

To prevent damage to the valve seal, due to the disc rotating past the fully closed position, use the following procedures:

- **For actuators with an adjustable turnbuckle, such as the Type 1051, 1052, or 1061 actuator, the turnbuckle must be adjusted so that the valve is closed (determined by measuring as shown in figure 8) when the diaphragm plate or piston is against the actuator travel stop.**

- **For manually-operated actuators or actuators without adjustable linkage, such as a Type 1066 or 1066SR actuator, make certain the actuator travel stop prevents the disc from rotating past the fully closed position.**

3. For actuators with an adjustable turnbuckle, adjust the turnbuckle to its minimum length to prevent damage. If necessary, refer to the appropriate actuator instruction manual for assistance with adjustment.

4. For power actuators, refer to figure 7 to locate the view of the mounting style and position to be used. When adjusting the actuator, be certain that the disc is rotated in the proper direction (clockwise to close when viewed from the actuator side of the valve) and that the disc is not rotated beyond the limits defined in the Installation section of this instruction manual.

5. For actuators with turnbuckles, adjust the turnbuckle to bring the disc to the fully closed position at the end of the actuator stroke. Refer to the appropriate actuator instruction manual for assistance.

6. To determine the fully closed disc position (zero degrees of disc rotation), measure the distances between the disc face and the retaining ring face (or from a line from the top to the bottom of the valve body) at the top and bottom of the valve as shown in figure 8. When necessary, adjust the actuator to rotate the disc slightly until the two measurements are equal.

7. Reinstall the seal ring according to the procedure in the Replacing Seal Ring section.

8510B Valve (EMA)

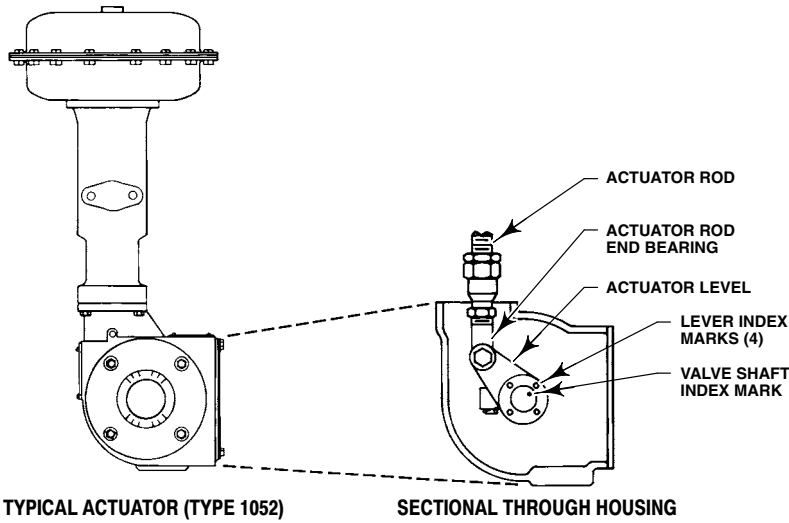

A3344/IL

ACTUATOR MOUNTING		VALVE CLOSED ⁴	MOUNTING POSITION 1 ⁵	MOUNTING POSITION 2 ⁵	MOUNTING POSITION 3 ⁵	MOUNTING POSITION 4 ⁵
RIGHT-HAND ¹	STYLE A (PDTC)					
	STYLE B (PDTC) ³					
LEFT-HAND ²	STYLE C (PDTC) ³					
	STYLE D (PDTC)					

NOTES:

- ¹ WHEN ONE IS FACING THE INLET, THE ACTUATOR IS TO THE RIGHT OF THE VALVE BODY.
- ² WHEN ONE IS FACING THE INLET, THE ACTUATOR IS TO THE LEFT OF THE VALVE BODY.
- ³ FOR 60-DEGREE OPERATION WITH PUSH-DOWN-TO-CLOSE ACTION (EXTENDING ACTUATOR ROD CLOSES VALVE), ROTATE ACTUATOR LEVER COUNTERCLOCKWISE SO THAT LEVER INDEX MARK IS OFFSET 1 SPLINE TOOTH FROM VALVE SHAFT INDEX MARK FOR 2- THROUGH 4 INCH VALVE BODY SIZES AND 2 SPLINE TEETH FROM VALVE SHAFT INDEX MARK FOR 6- THROUGH 12-INCH VALVE BODY SIZES.
- ⁴ CURVED ARROWS IN "VALVE CLOSED" COLUMN INDICATE ROTATION REQUIRED TO OPEN VALVE (COUNTERCLOCKWISE WHEN VIEWED FROM ACTUATOR SIDE OF VALVE).
- ⁵ ARROWS IN "MOUNTING POSITION" COLUMNS INDICATE DIRECTION OF ACTUATOR ROD TRAVEL REQUIRED TO OPEN VALVE.
- 6. PDTC—PUSH DOWN TO CLOSE; PDTO—PUSH DOWN TO OPEN.

43A5323-B
B1125-1/IL

Figure 7. Lever/Shaft/Disc Orientation with Valve Closed

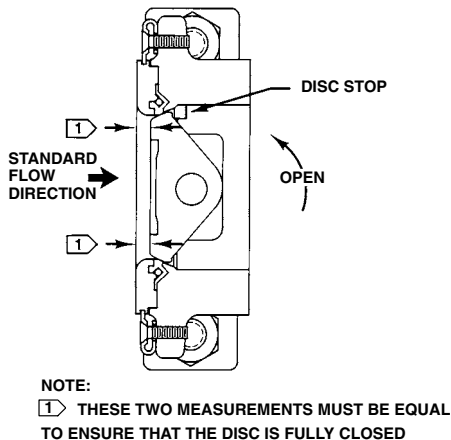

Figure 8. Sectional of Typical Valve Body

valve, because they will void your warranty, might adversely affect the performance of the valve, and might jeopardize worker and workplace safety.

Note

Neither Emerson, Emerson Process Management, Fisher, nor any of their affiliated entities assumes responsibility for the selection, use and maintenance of any product. Responsibility for the selection, use, and maintenance of any product remains with the purchaser and end-user.

Parts Ordering

When corresponding with your Emerson Process Management sales office about this equipment, always mention the valve serial number. When ordering replacement parts, also specify the complete 11-character part number of each part required from the following parts list.

WARNING

Use only genuine Fisher replacement parts. Components that are not supplied by Emerson Process Management should not, under any circumstances, be used in any Fisher

Parts Kits

Retrofit Kits for ENVIRO-SEAL Packing

Retrofit kits are available for replacing the packing in an existing valve with an ENVIRO-SEAL packing system. These kits are available for single PTFE or graphite packing. All parts required for installation of the ENVIRO-SEAL packing system into an existing Type 8510B control valve are included in the kits. Select two kits, one for the actuator end of the valve and one for the outboard end.

Worn shafts, packing box damage, or other components that do not meet Emerson Process Management finish specifications, dimensional tolerances, and design specifications, may adversely alter the performance of the retrofit kit.

ENVIRO-SEAL® Packing System Retrofit Kits for Splined Shafts

SHAFT DIAMETER mm	SHAFT DIAMETER Inches	SINGLE PTFE PACKING		GRAPHITE PACKING	
		For Actuator End Packing Box	For Outboard End Packing Box	For Actuator End Packing Box	For Outboard End Packing Box
12.7	1/2	RRTYXRT0012	RRTYXRT0082	RRTYXRT0312	RRTYXRT0382
15.9	5/8	RRTYXRT0022	RRTYXRT0092	RRTYXRT0322	RRTYXRT0392
19.1	3/4	RRTYXRT0032	RRTYXRT0102	RRTYXRT0332	RRTYXRT0402
25.4	1	RRTYXRT0052	RRTYXRT0112	RRTYXRT0352	RRTYXRT0412
31.8	1-1/4	RRTYXRT0062	RRTYXRT0122	RRTYXRT0362	RRTYXRT0422
38.1	1-1/2	RRTYXRT0072	RRTYXRT0132	RRTYXRT0372	RRTYXRT0432

8510B Valve (EMA)

ENVIRO-SEAL® Packing System Retrofit Kits for Double D End Connection with Anti-Blowout Shaft

SHAFT DIAMETER	SHAFT DIAMETER	SINGLE PTFE PACKING		GRAPHITE PACKING			
		mm	Inches	For Actuator End Packing Box	For Outboard End Packing Box	For Actuator End Packing Box	For Outboard End Packing Box
12.7	1/2			RRTYXRT0972	RRTYXRT0082	RRTYXRT1072	RRTYXRT0382
15.9	5/8			RRTYXRT0982	RRTYXRT0092	RRTYXRT1082	RRTYXRT0392
19.1	3/4			RRTYXRT0992	RRTYXRT0102	RRTYXRT1092	RRTYXRT0402
25.4	1			RRTYXRT1012	RRTYXRT0112	RRTYXRT1102	RRTYXRT0412
31.8	1-1/4			RRTYXRT1022	RRTYXRT0122	RRTYXRT1112	RRTYXRT0422
38.1	1-1/2			RRTYXRT1032	RRTYXRT0132	RRTYXRT1122	RRTYXRT0432

Repair Kits for ENVIRO-SEAL Packing

Repair kits for ENVIRO-SEAL PTFE packing include one packing set and two anti-extrusion washers. Repair kits for ENVIRO-SEAL graphite packing include two packing rings and two anti-extrusion rings. A quantity of two of the appropriate kit is

required to repair both ends of the valve.

Worn shafts, packing box damage, or other components that do not meet Emerson Process Management finish specifications, dimensional tolerances, and design specifications, may adversely alter the performance of the repair kit.

ENVIRO-SEAL® Packing System Repair Kits

SHAFT DIAMETER	SHAFT DIAMETER	FOR PTFE PACKING	FOR GRAPHITE PACKING
mm	Inches		
12.7	1/2	RRTYX000012	13B8816X012
15.9	5/8	RRTYX000022	13B8816X032
19.1	3/4	RRTYX000032	13B8816X052
25.4	1	RRTYX000052	13B8816X092
31.8	1-1/4	RRTYX000062	13B8816X112
38.1	1-1/2	RRTYX000072	13B8816X142

Parts List

Key	Description	Part Number
1	Valve Body	---
Note		
<p>Part numbers are shown for recommended spares only. For part numbers not shown, contact your Emerson Process Management sales office.</p> <p>Except where indicated, sizes shown are valve body sizes.</p>		
Note		
<p>The valve body is available as an assembly only. If valve body replacement information is necessary, contact your Emerson Process Management sales office.</p>		
2*	Seal Retainer	See following table
<p>Part numbers are listed for steel and stainless steel only. For alloy construction part numbers, contact your Emerson Process Management sales office.</p>		
3	Valve Disc	
4*	Seal Ring ⁽¹⁾ , PTFE	See following table
4*	Seal Ring Assembly, All-metal seal S31600 (316 SST) & graphite laminate (Assembly includes gaskets. For gasket only, see key 4C below)	
	2-inch	17A7544X022
	3-inch	17A7550X022
	4-inch	17A7556X022
	6-inch	17A8171X022
	8-inch	17A8172X022
	10-inch	18A1129X022
	12-inch	18A1139X022
4C*	Gasket, graphite laminate (2 req'd)	
	8-inch	17A7567X012
	10-inch	18A1128X012
5*	Spring (PTFE seal ring only) ⁽¹⁾	See following table
6*	Bearing (2 req'd)	
<p>PTFE/composition lining with S31603 (316L SST) jacket (Reinforced PTFE in phenolic resin. Emerson Process Management designation is FMS 30B4.)</p>		
	2-inch	12A9015X272
	3-inch	12A8904X292
	4-inch	12A8985X332
	6-inch	12A8819X362
	8 & 10-inch	12A8965X262
	12-inch	12A8928X242
<p>Filled PTFE with S31603 (316L SST) jacket (PTFE with selected fillers. Emerson Process Management designation is FMS 30B5.)</p>		
	2-inch	12A9015X282
	3-inch	12A8904X302
	4-inch	12A8985X322
	6-inch	12A8819X372
	8 & 10-inch	12A8965X272
	12-inch	12A8928X272

*Recommended spare parts
 1. To make certain that a spring is available with each seal ring, a new spring (key 5) should be ordered to be stocked with each ring ordered.

Instruction Manual

Form 5284
September 2006

8510B Valve (EMA)

Key	Description	Part Number	Key	Description	Part Number
6*	Bearing (2 req'd) (continued)		13*	Packing Set (2 req'd) (continued)	
	S44004 (440C SST)			3-inch	1R579501012
	2-inch	14A6543X012		4-inch	12A8995X012
	3-inch	12A9300X012		6-inch	12A8832X012
	4-inch	14A5698X012		8 & 10-inch	12A8951X012
	6-inch	14A4618X012		12-inch	12A8935X012
	8 & 10-inch	14A5699X012		Packing Parts (included in packing set)	
	12-inch	14A6549X012		Female Adaptor (2 req'd)	
	Alloy 6B			Carbon-filled PTFE (standard)	
	2-inch	14A6544X012		2-inch	1H7844X0012
	3-inch	14A6545X012		3-inch	1R5794X0012
	4-inch	14A6546X012		4-inch	12A8992X022
	6-inch	14A6547X012		6-inch	12A8831X022
	8 & 10-inch	14A6548X012		8 & 10-inch	12A8953X022
	12-inch	14A6550X012		12-inch	12A8932X022
	Silver-plated alloy 6B			PTFE (nonconductive)	
	2-inch	14A6536X012		2-inch	1H784401012
	3-inch	12A9161X012		3-inch	1R579401012
	4-inch	14A6537X012		4-inch	12A8992X012
	6-inch	14A2498X012		6-inch	12A8831X012
	8 & 10-inch	14A6538X012		PTFE (nonconductive)	
	12-inch	14A6539X012		8 & 10-inch	12A8953X012
7*	Spacer			12-inch	12A8932X012
	For PTFE lined or filled PTFE bearings			Packing Ring, PTFE (6 req'd)	
	PTFE/S31603 (316LSST) (2 req'd)			2-inch	1H784301012
	2-inch	16A6036X092		3-inch	1R579301012
	3-inch	16A6045X162		4-inch	12A8994X012
	4-inch	16A6041X152		6-inch	12A8830X012
	6-inch	16A6033X102		8 & 10-inch	12A8954X012
	8 & 10-inch	16A6055X062		12-inch	12A8933X012
	12-inch	16A6061X152		Male Adaptor, PTFE (2 req'd)	
	For S44004 (440C SST) bearings			2-inch	1H784201012
	S17700 (17-7 PH SST) (4 req'd)			3-inch	1R579201012
	2-inch	18B9857X022		4-inch	12A8993X012
	3-inch	11B9444X012		6-inch	12A8829X012
	4-inch	11B9608X012		8 & 10-inch	12A8952X012
	6-inch	12B1356X012		12-inch	12A8934X012
	8 & 10-inch	12B1997X012	13*	Packing Ring (8 req'd) (not req'd for V-ring packing set)	
	12-inch	12B3905X012		Graphite ribbon	
	For alloy 6B or silver-plated alloy 6B bearings			2-inch	12A9134X012
	Alloy 6B (4 req'd)			3-inch	12A9135X012
	2-inch	18B9857X022		4-inch	12A9136X012
	3-inch	11B9444X022		6-inch	12A9137X012
	4-inch	11B9608X022		8 & 10-inch	12A9138X012
	6-inch	12A1356X022		12-inch	12A9139X012
	8 & 10-inch	12B1997X022			
	12-inch	12B3905X022			
8	Cap Screw (SST)				
	2- through 8-inch (2 req'd) 10 & 12-inch (4 req'd)				
9	Packing Flange				
10	Packing Flange				
11	Packing Flange Stud (4 req'd)				
12	Packing Flange Nut (4 req'd)				
13*	Packing Set (2 req'd)				
	PTFE & carbon-filled PTFE V-ring (standard)			PTFE-composition (6 req'd)	
	2-inch	12A9016X022		2-inch	1P390501042
	3-inch	1R5795X0012		3-inch	1J822501042
	4-inch	12A8995X022		4-inch	14A1937X012
	6-inch	12A8832X022		6-inch	14A0915X012
	8 & 10-inch	12A8951X022		8 & 10-inch	14A0916X012
	12-inch	12A8935X022		12-inch	14A1933X012
	PTFE V-ring (nonconductive)			Graphite composition/N06600 (2 req'd)	
	2-inch	12A9016X012		2-inch	1P3905X0172
				3-inch	1J8225X0182
				4-inch	14A1937X042

Note

When ordering a PTFE-composition & graphite composition/N06600 packing ring arrangement, order 6 PTFE-composition packing rings and 2 graphite composition/N06600 packing rings per valve.

8510B Valve (EMA)

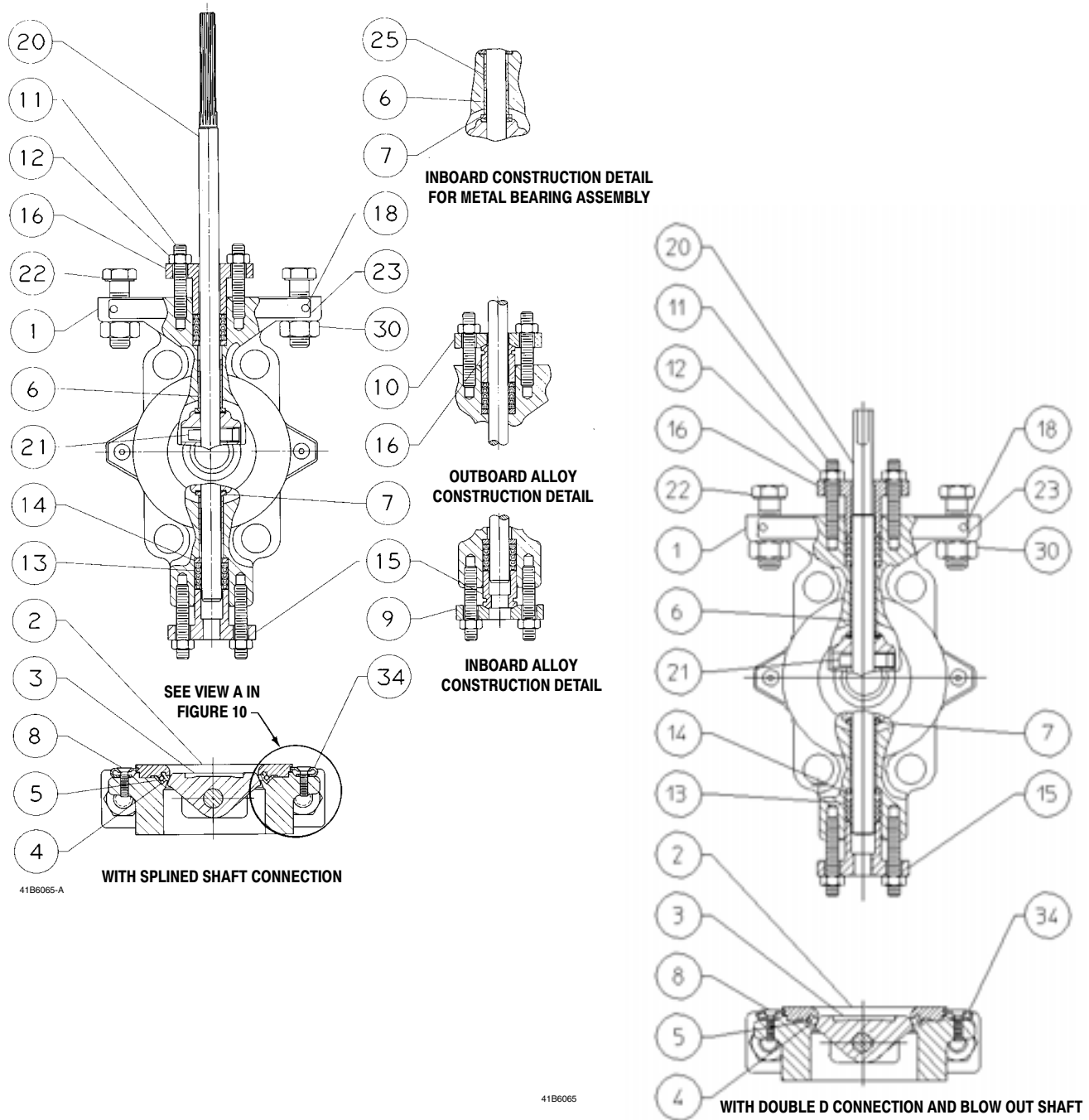

Figure 9. Typical Type 8510B Valve Assemblies

Key	Description	Part Number	Key	Description	Part Number
13*	Packing Ring (8 req'd) (not req'd for V-ring packing set)		14*	Packing Box Ring (continued)	
	(continued)			3-inch	16A6083X092
	6-inch	14A0915X042		4-inch	16A6084X062
	8 & 10-inch	14A0916X072		6-inch	16A6085X062
	12-inch	14A1933X022		8 & 10-inch	16A6086X082
14*	Packing Box Ring			12-inch	16A6087X072
	S31600 (316L SST) (2 req'd)		15	Packing follower, CF8M (316 SST)	
	2-inch	16A6082X052	16	Packing follower, SST	

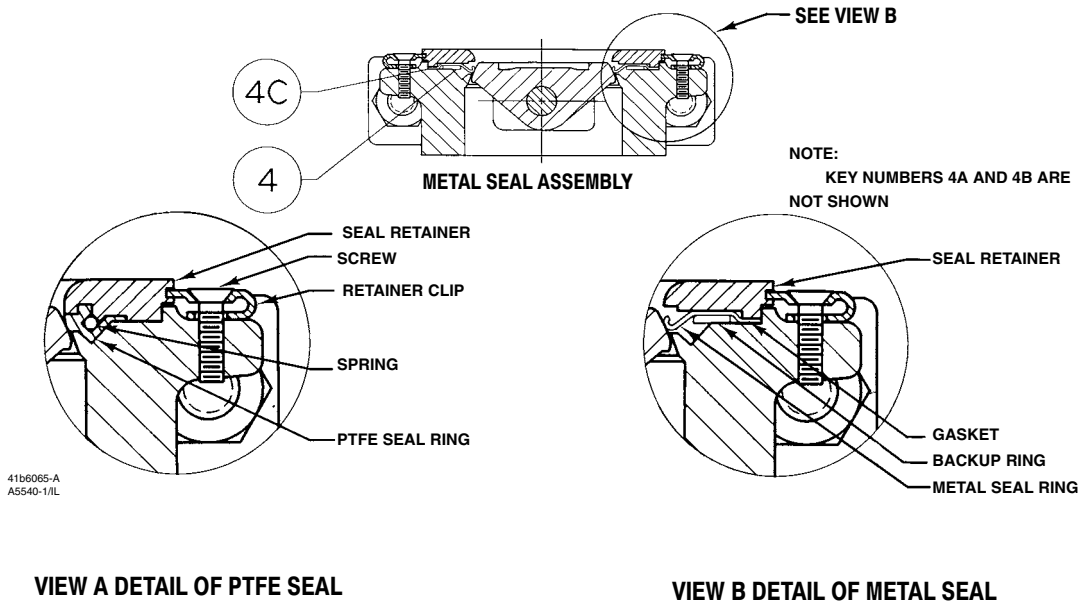

Figure 10. Seal Details

Key	Description	Part Number	Key	Description	Part Number
18	Drive Screw, SST (2 req'd)		20	Valve Shaft (continued)	
20	Valve Shaft			Double D End Connection and Anti-Blowout Shaft	
	Splined Shaft Connection			S20190	
	S17400 (17-4 PH SST)			Do not use with S44004 (440C SST) bearings	
	2-inch	31B2526X012		2-inch	3Q57352F022
	3-inch	31B6892X012		3-inch	3Q57353F022
	4-inch	31B9456X012		4-inch	3Q57354F022
	6-inch	32B1347X012		6-inch	3Q57355F022
	8-inch	32B1994X012		8-inch	3Q57356F022
	10-inch	32B2824X012		10-inch	3Q57357F022
	12-inch	32B3901X012		12-inch	3Q57358F022
	S20190		21*	Taper Key, S20910	
	Do not use with S44004 (440C SST) bearings			2-inch	11B0654X012
	2-inch	31B2526X022		3-inch	11B0674X012
	3-inch	31B6892X022		4-inch	11B0674X012
	4-inch	31B9456X022		6-inch	11B0695X012
	6-inch	32B1347X022		8 & 10-inch	11B0722X012
	8-inch	32B1994X022		12-inch	11B4684X012
	10-inch	32B2824X022			
	12-inch	32B3887X022	22	Cap Screw (2 req'd for 2 & 3-inch; 4 req'd on all other sizes)	
	Double D End Connection and Anti-Blowout Shaft		23	Nameplate, stainless steel	11B9434X0A2
	S17400 (17-4 PH SST)		25*	Bearing Stop (2 req'd) S31600 (316 SST)	
	2-inch	3Q57352F012		For use with metal bearings (not shown)	
	3-inch	3Q57353F012		2-inch	14A6531X022
	4-inch	3Q57354F012		3-inch	12A9162X012
	6-inch	3Q57355F012		4-inch	14A5697X022
	8-inch	3Q57356F012		6-inch	14A2497X012
	10-inch	3Q57357F012		8 & 10-inch	14A5700X022
	12-inch	3Q57358F012		12-inch	14A6532X022

*Recommended spare parts

8510B Valve (EMA)

Key	Description	Part Number	Key	Description	Part Number
26	Line Flange Stud (not shown)		102	Packing Flange (2 required)	
27	Packing Washer, zinc (6 req'd)		103	Spring Pack Assembly	
29*	Line Flange Gasket, FGM (2 req'd) (use only when specified) (not shown) Recommended for temperatures above 650°F (343°C)		104	Spring Pack Outboard	
	Class 150		105*	Packing Set	
	2-inch	16A6224X012		Single PTFE Packing	
	3-inch	16A6226X012		2-inch	12B7053X012
	4-inch	16A6228X012		3-inch	12B7402X012
	6 & 8-inch	16A6231X012		4-inch	12B7414X012
	10-inch	16A6237X012		6-inch	12B7438X012
	12-inch	16A6239X012		8-inch	12B7450X012
	Class 300			10-inch	12B7450X012
	2-inch	16A6225X012		12-inch	12B7643X012
	3-inch	16A6227X012		Graphite Packing	
	4-inch	16A6229X012		2-inch	13B8816X012
	6 & 8-inch	16A6232X012	105*	3-inch	13B8816X032
	10-inch	16A6238X012		Packing Set	
	12-inch	16A6240X012		Graphite Packing (continued)	
	Class 600			4-inch	13B8816X052
	2-inch	16A6225X012		6-inch	13B8816X092
	3-inch	16A6227X012		8-inch	13B8816X112
	4-inch	16A6230X012		10-inch	13B8816X112
	6 & 8-inch	16A6233X012		12-inch	13B8816X142
30	Hex Nut		106*	Anti-extrusion Ring	
32	Nameplate, stainless steel			Single PTFE PackinG	
33	Nameplate Wire			2-inch	12B7054X012
34	Retainer Clip, S31600			3-inch	12B7406X012
130	Clamp, stainless steel (req'd w/nonconductive packing)			4-inch	12B7418X012
131	Bonding Strap Assembly (req'd w/nonconductive packing)			6-inch	12B7442X012
				8-inch	12B7454X012
				10-inch	12B7454X012
				12-inch	12B7646X012
			107*	Packing Box Ring	
				2-inch	16A6082X012
				3-inch	16A6083X012
				4-inch	16A6084X012
				6-inch	16A6085X012
				8-inch	16A6086X012
				10-inch	16A6086X012
				12-inch	16A6086X012
			111	Tag	
			112	Cable Tie	

ENVIRO-SEAL® PACKING

100	Packing Stud (4 required)
101	Packing Nut (4 required)

Key 2*, Seal Retainer, ASME

VALVE SIZE, INCHES	FOR COMPOSITION SEAL		FOR ALL-METAL SEAL	
	SA-514-70 Steel	S31603 (316L SST)	SA-515-70 Steel	S31603 (316L SST)
2	21B4666X012	21B4666X062	21B4667X012	21B4667X032
3	21B6894X012	21B6894X062	21B6895X012	21B6895X032
4	21B9458X012	21B9458X062	21B9459X012	21B9459X032
6	22B1343X012	22B1343X032	22B1344X012	22B1344X032
8	22B1988X012	22B1988X032	22B1989X012	22B1989X032
10	28A1124X012	28A1124X132	28A1125X012	28A1125X132
12	28A1134X012	28A1134X172	28A1135X012	28A1135X092

Instruction Manual

Form 5284
September 2006

8510B Valve (EMA)

Key 2* Seal Retainer, DIN

VALVE SIZE, INCHES	SEAL MATERIAL	SEAL RETAINER MATERIAL			
		SA-515-70	1.0481 Steel DIN 17155	1.4571 Steel DIN 17440	S31603 (316L SST)
For DIN PN 63-100					
2	PTFE Composition	21B4668X092	21B4668X152	21B4668X162	21B4668X142
	All-Metal Seal	21B4669X062	21B4669X092	21B4669X102	21B4669X082
3	PTFE Composition	21B6896X092	21B6896X152	21B6896X162	21B6896X142
	All-Metal Seal	21B6897X062	21B6897X092	21B6897X102	21B6897X082
4	PTFE Composition	21B9458X212	21B9458X272	21B9458X282	21B9458X262
	All-Metal Seal	21B9459X112	21B9459X142	21B9459X152	21B9459X132
6	PTFE Composition	22B1345X092	22B1345X152	22B1345X162	22B1345X142
	All-Metal Seal	22B1346X062	22B1346X092	22B1346X102	22B1346X082
8	PTFE Composition	22B1992X092	22B1992X152	22B1992X162	22B1992X142
	All-Metal Seal	22B1993X062	22B1993X092	22B1993X102	22B1993X082
For DIN PN 10-40					
2	PTFE Composition	21B4668X012	21B4668X072	21B4668X082	21B4668X062
	All-Metal Seal	21B4669X012	21B4669X042	21B4669X052	21B4669X032
3	PTFE Composition	21B6896X012	21B6896X072	21B6896X082	21B6896X062
	All-Metal Seal	21B6897X012	21B6897X042	21B6897X052	21B6897X032
4	PTFE Composition	21B9458X012	21B9458X192	21B9458X202	21B9458X062
	All-Metal Seal	21B9459X012	21B9459X092	21B9459X102	21B9459X032
6	PTFE Composition	22B1345X012	22B1345X072	22B1345X082	22B1345X062
	All-Metal Seal	22B1346X012	22B1346X042	22B1346X052	22B1346X032
For DIN PN 10-16					
8	PTFE Composition	22B1990X012	22B1990X072	22B1990X082	22B1990X062
	All-Metal Seal	22B1991X012	22B1991X042	22B1991X052	22B1991X032
10	PTFE Composition	22B2826X012	22B2826X072	22B2826X082	22B2826X062
	All-Metal Seal	22B2827X012	22B2827X042	22B2827X052	22B2827X032
For DIN PN 25-40					
8	PTFE Composition	22B1992X012	22B1992X072	22B1992X082	22B1992X062
	All-Metal Seal	22B1993X012	22B1993X042	22B1993X052	22B1993X032
10	PTFE Composition	22B2828X012	22B2828X072	22B2828X082	22B2828X062
	All-Metal Seal	22B2829X012	22B2829X042	22B2829X052	22B2829X032
For DIN PN 10					
12	PTFE Composition	22B3889X012	22B3889X072	22B3889X082	22B3889X062
	All-Metal Seal	22B3890X012	22B3890X042	22B3890X052	22B3890X032
For DIN PN 16					
12	PTFE Composition	22B3891X012	22B3891X072	22B3891X082	22B3891X062
	All-Metal Seal	22B3892X012	22B3892X042	22B3892X052	22B3892X032
For DIN PN 25					
12	PTFE Composition	22B3893X012	22B3893X072	22B3893X082	22B3893X062
	All-Metal Seal	22B3894X012	22B3894X042	22B3894X052	22B3894X032
For DIN PN 40					
12	PTFE Composition	22B3895X012	22B3895X072	22B3895X082	22B3895X062
	All-Metal Seal	22B3896X012	22B3896X042	22B3896X052	22B3896X032
For DIN PN 63					
12	PTFE Composition	22B3895X092	22B3895X152	22B3895X162	22B3895X142
	All-Metal Seal	22B3896X062	22B3896X092	22B3896X102	22B3896X082

8510B Valve (EMA)

Key 4* Seal Ring and Key 5* Seal Spring used with PTFE Composition Seals

VALVE SIZE, INCHES	KEY NUMBER	SEAL RING MATERIAL IS PTFE (KEY 4)			
		Spring Material (Key 5)			
		S31600 (316 SST)	N05500	N10276 (Alloy 276)	N08020 (Alloy 20)
2	4	22A9023X012	22A9023X012	22A9023X012	22A9023X012
	5	12A9022X012	12A9022X022	12A9022X032	12A9022X042
3	4	22A8897X012	22A8897X012	22A8897X012	22A8897X012
	5	12A8902X012	12A8902X022	12A8902X032	12A8902X042
4	4	22A8986X012	22A8986X012	22A8986X012	22A8986X012
	5	12A8991X012	12A8991X022	12A8991X032	12A8991X042
6	4	22A8825X012	22A8825X012	22A8825X012	22A8825X012
	5	12A8818X012	12A8818X022	12A8818X032	12A8818X042
8	4	22A8961X012	22A8961X012	22A8961X012	22A8961X012
	5	12A8974X012	12A8974X022	12A8974X032	12A8974X042
10	4	22A8946X012	22A8946X012	22A8946X012	22A8946X012
	5	12A8948X012	12A8948X022	12A8948X032	12A8948X042
12	4	22A8920X012	22A8920X012	22A8920X012	22A8920X012
	5	12A8922X012	12A8922X022	12A8922X032	12A8922X042

*Recommended spare parts

ēdisc, ēplug, ENVIRO-SEAL, Vee-Ball and Fisher are marks owned by Fisher Controls International LLC, a member of the Emerson Process Management business division of Emerson Electric Co. Emerson Process Management, Emerson, and the Emerson logo are trademarks and service marks of Emerson Electric Co. All other marks are the property of their respective owners.

The contents of this publication are presented for informational purposes only, and while every effort has been made to ensure their accuracy, they are not to be construed as warranties or guarantees, express or implied, regarding the products or services described herein or their use or applicability. We reserve the right to modify or improve the designs or specifications of such products at any time without notice.

Neither Emerson, Emerson Process Management, Fisher, nor any of their affiliated entities assumes responsibility for the selection, use and maintenance of any product. Responsibility for the selection, use and maintenance of any product remains with the purchaser and end-user.

Emerson Process Management

Fisher

Marshalltown, Iowa 50158 USA

Cernay 68700 France

Sao Paulo 05424 Brazil

Singapore 128461

www.Fisher.com

