

ControlWave Corrector

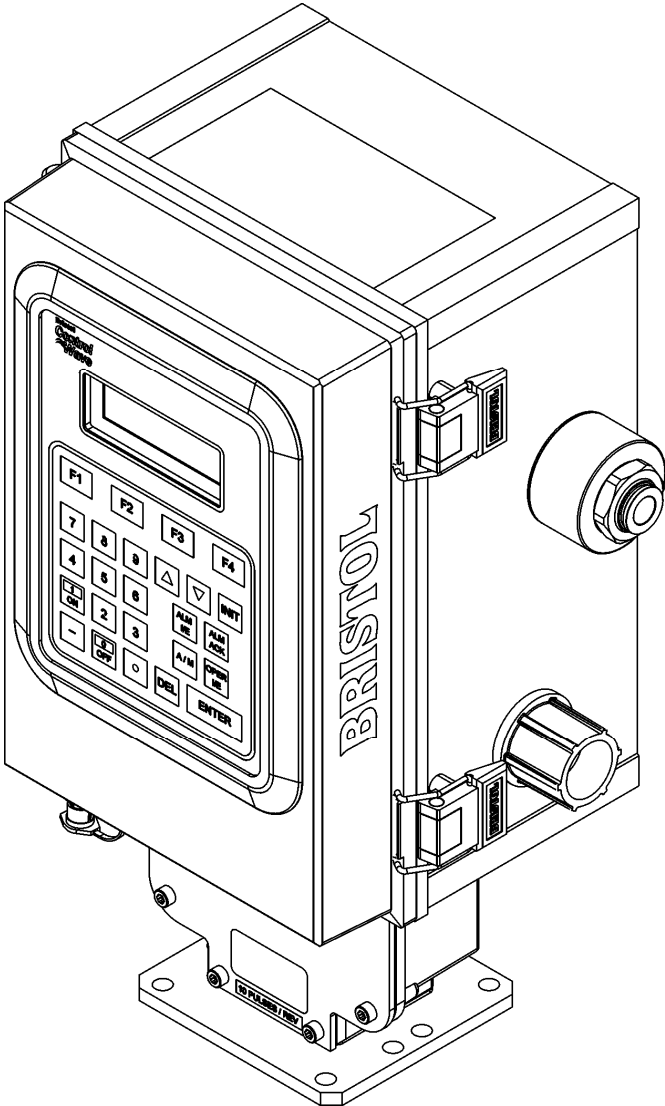

IMPORTANT! READ INSTRUCTIONS BEFORE STARTING!

Be sure that these instructions are carefully read and understood before any operation is attempted. Improper use of this device in some applications may result in damage or injury. The user is urged to keep this book filed in a convenient location for future reference.

These instructions may not cover all details or variations in equipment or cover every possible situation to be met in connection with installation, operation or maintenance. Should problems arise that are not covered sufficiently in the text, the purchaser is advised to contact Emerson Process Management, Remote Automation Solutions for further information.

EQUIPMENT APPLICATION WARNING

The customer should note that a failure of this instrument or system, for whatever reason, may leave an operating process without protection. Depending upon the application, this could result in possible damage to property or injury to persons. It is suggested that the purchaser review the need for additional backup equipment or provide alternate means of protection such as alarm devices, output limiting, fail-safe valves, relief valves, emergency shutoffs, emergency switches, etc. If additional information is required, the purchaser is advised to contact Remote Automation Solutions.

RETURNED EQUIPMENT WARNING

When returning any equipment to Remote Automation Solutions for repairs or evaluation, please note the following: The party sending such materials is responsible to ensure that the materials returned to Remote Automation Solutions are clean to safe levels, as such levels are defined and/or determined by applicable federal, state and/or local law regulations or codes. Such party agrees to indemnify Remote Automation Solutions and save Remote Automation Solutions harmless from any liability or damage which Remote Automation Solutions may incur or suffer due to such party's failure to so act.

ELECTRICAL GROUNDING

Metal enclosures and exposed metal parts of electrical instruments must be grounded in accordance with OSHA rules and regulations pertaining to "Design Safety Standards for Electrical Systems," 29 CFR, Part 1910, Subpart S, dated: April 16, 1981 (OSHA rulings are in agreement with the National Electrical Code).

The grounding requirement is also applicable to mechanical or pneumatic instruments that include electrically operated devices such as lights, switches, relays, alarms, or chart drives.

EQUIPMENT DAMAGE FROM ELECTROSTATIC DISCHARGE VOLTAGE

This product contains sensitive electronic components that can be damaged by exposure to an electrostatic discharge (ESD) voltage. Depending on the magnitude and duration of the ESD, this can result in erratic operation or complete failure of the equipment. Read supplemental document S14006 for proper care and handling of ESD-sensitive components.

Contents

Chapter 1 – Introduction 1-1

1.1	Scope of the Manual	1-2
1.2	Physical Description	1-2
1.3	CPU/System Controller Board	1-3
1.4	Power Options	1-5
1.5	I/O Options	1-5
1.6	Software Tools	1-6
1.7	Overview of the Gas Flow Measurement Application	1-8
1.7.1	Data Acquisition – Static Pressure, Differential Pressure, Temperature Variables	1-8
1.7.2	Flow and Volume Calculations	1-8
1.7.3	Flow Rate and Flow Time Calculations (AGA3)	1-9
1.7.4	Flow Rate and Flow Time Calculations (AGA7)	1-9
1.7.5	Extension Calculation and Analog Averaging	1-9
1.7.6	Energy Calculation	1-10
1.7.7	Volume and Energy Integration	1-10
1.7.8	Historical Data Storage (Audit Records/ Archive Files)	1-10
1.7.9	Run Switching	1-12
1.7.10	Sampler and Odorizer	1-12
1.7.11	Chromatograph Interface	1-12
1.7.12	Nominations	1-13

Chapter 2 – Installation 2-1

2.1	Site Considerations	2-1
2.1.1	Class I, Div 2 Installation Considerations	2-3
2.2	Installation Overview	2-4
2.3	Unpacking Components	2-5
2.4	Mounting the ControlWave Corrector Assembly	2-5
2.4.1	Configuring the TeleCounter Assembly	2-13
2.4.2	Configuring the ISPROX Module (Option)	2-13
2.4.3	Connection to the Gage Pressure Transducer (GPT)	2-14
2.4.4	Grounding the Housing	2-17
2.5	Configuring the CPU/System Controller Board	2-18
2.5.1	Setting DIP Switches on the CPU/System Controller Board	2-19
2.5.2	Setting Jumpers on the CPU/System Controller Board	2-21
2.5.3	General Wiring Guidelines	2-22
2.5.4	Wiring Power to the CPU/System Controller Board	2-23
2.5.5	Connections to RS-232 Serial Port(s) on the CPU/System Controller Board	2-25
2.5.6	Connections to the COM3 (RS-485/RS-232) Serial Port on the CPU/System Controller Board	2-30
2.5.7	Connections to the Ethernet Port on the CPU/System Controller Board	2-32
2.6	Radio-Ready and Case Mounted Modem or Radio	2-33
2.7	Mounting the Solar Panel	2-34
2.8	Optional Display/Keypads	2-37

Chapter 3 – I/O Configuration and Wiring 3-1

3.1	I/O Options	3-1
3.2	Process I/O Board	3-2
3.2.1	Setting Jumpers on the Process I/O Board	3-2
3.2.2	Setting DIP Switches on the Process I/O Board	3-2
3.3	I/O Wiring	3-4

3.3.1	Non-Isolated Discrete Inputs (DI) on TB2 and TB3 of Process I/O Board	3-6
3.3.2	Non-Isolated Discrete Outputs (DO) on TB3 of Process I/O Board.....	3-7
3.3.3	Non-Isolated Analog Inputs (AI) on TB6 of Process I/O Board	3-8
3.3.4	Non-Isolated Analog Output (AO) on TB7 of Process I/O Board.....	3-9
3.3.5	Non-Isolated Pulse Counter/Discrete Inputs on TB5 of CPU/System Controller Bd..	3-10
3.3.6	Non-Isolated High Speed Counter/ Discrete Inputs on TB4 of Process I/O Board	3-13
3.3.7	Resistance Temperature Device (RTD) Inputs on CPU/System Controller Board.....	3-14
3.3.8	Connections to a Bristol Model 3808 Transmitter	3-16

Chapter 4 – Operation **4-1**

4.1	Powering Up/Powering Down the ControlWave Corrector	4-1
4.2	Communicating with the ControlWave Corrector.....	4-2
4.2.1	Default Comm Port Settings	4-2
4.2.2	Changing Port Settings	4-3
4.2.3	Collecting Data from the ControlWave Corrector	4-3
4.3	Creating and Downloading an Application (ControlWave Project)	4-3
4.4	Creating and Maintaining Backups	4-4
4.4.1	Creating a Zipped Project File (*.ZWT) For Backup	4-4
4.4.2	Saving Flash Configuration Parameters (*.FCP)	4-6
4.4.3	Backing up Data.....	4-7

Chapter 5 – Service and Troubleshooting **5-1**

5.1	Upgrading Firmware.....	5-2
5.2	Removing or Replacing Components	5-6
5.2.1	Accessing Modules for Testing.....	5-6
5.2.2	Removing/Replacing the CPU/System Controller Board and the Process I/O Board ..	5-6
5.2.3	Removing/Replacing the Primary Battery System.....	5-7
5.2.4	Removing/Replacing the Backup Battery	5-8
5.2.5	Enabling / Disabling the Backup Battery.....	5-9
5.2.6	Removing/Replacing the Case-Mounted Radio or Modem	5-9
5.2.7	Removing/Replacing the GPT Transducer	5-10
5.2.8	Removing/Replacing the TeleCounter (Pulser) Assembly.....	5-10
5.3	General Troubleshooting Procedures	5-11
5.3.1	Common Communication Configuration Problems.....	5-11
5.3.2	Checking LEDs	5-12
5.3.3	Checking LCD Status Codes	5-12
5.3.4	Wiring/Signal Checks	5-12
5.4	WINDIAG Diagnostic Utility.....	5-13
5.4.1	Available Diagnostics.....	5-14
5.5	Core Updump.....	5-17
5.6	Calibration Checks	5-18

Appendix A – Special Instructions for Class I, Division 2 Hazardous Locations **A-1**

Appendix Z – Sources for Obtaining Material Safety Data Sheets **Z-1**

Index **IND-1**

Chapter 1 – Introduction

This manual focuses on the hardware aspects of the ControlWave[®] Corrector. For information about the software used with the ControlWave Corrector, refer to:

- *ControlWave Flow Measurement Applications Guide (D5137)*,
- *Getting Started with ControlWave Designer (D5085)*
- *ControlWave Designer Programmer's Handbook (D5125)*
- ControlWave Designer online help

This chapter provides an overview of the ControlWave Corrector and its components and details the structure of this manual

In This Chapter

1.1	Scope of the Manual.....	1-2
1.2	Physical Description	1-2
1.3	CPU/System Controller Board.....	1-3
1.4	Power Options	1-5
1.5	I/O Options.....	1-5
1.6	Software Tools.....	1-6
1.7	Overview of the Gas Flow Measurement Application.....	1-8

The ControlWave Corrector is pre-programmed to meet API 21.1 requirements for a two-run metering station and measures static pressure and temperature for both runs and computes corrected volume (i.e., volume or base conditions), uncorrected volume and energy rates and totals. Most metering stations use the integral gauge pressure assembly for the first meter run and an external transmitter, such as the Bristol 3808 MVT, for the second meter run. ControlWave Correctors are appropriate to all applications for electronic meter correction, including those that require monitoring of additional I/O points or extension to two meters. ControlWave Correctors are designed to operate in an unprotected outdoor environment.

Features The ControlWave Corrector has the following key features:

- Exceptional performance and low power consumption through use of the ARM microprocessor.
- Very low power consumption to minimize costs of solar panel / battery power systems.
- Two CPU / System Controller board configurations (see *Table I-1*.)
- Integral gage pressure transducer (GPT) can be removed and replaced independently of the top-end electronics.
- Optional integrated TeleCounter (pulser) assembly mounts directly to rotary positive displacement meters.
- Three process I/O board configurations (see *Table I-2*).

- Two RS-232 and one RS-232/RS-485 asynchronous serial communication ports.
- Optional 10/100 MB Ethernet port
- Optional Display/Keypad.
- Wide operating temperature range:
 - Without lead acid battery: (–40 to +70°C) (–40 to 158°F)
 - With lead acid battery: (–20 to +60°C) (–4 to 140°F)
- Battery backup for Static RAM (SRAM) and real-time clock.
- Nonincendive Class I, Division 2 (Groups A, B, C and D) Hazardous Location approvals when installed in a suitable enclosure - see *Appendix A*.
- Cost-effective for small RTU/process controller applications.

1.1 Scope of the Manual

This manual contains the following chapters:

Chapter 1 Introduction	Provides an overview of the hardware Corrector general information about the ControlWave Corrector and its application software.
Chapter 2 Installation	Provides information on mounting the ControlWave Corrector and setting CPU jumpers and switches.
Chapter 3 I/O Configuration	Provides general information on wiring the process I/O points.
Chapter 4 Operation	Provides information on day-to-day operation of the ControlWave Corrector.
Chapter 5 Service and Troubleshooting	Provides information on service and troubleshooting procedures.

1.2 Physical Description

The ControlWave Corrector includes the following major components:

- Enclosure with a local communication port and LCD display/keypad.
- CPU/system controller board (SCB) mounts on edge within the enclosure – See *Section 1.3*
- Optional I/O – see *Section 1.5*.
- Internal mounting brackets and battery
- Gage pressure transducer (GPT) – See *Chapter 2*
- Optional RTD probe – See *Chapter 3*
- Radio/modem options
- TeleCounter (pulser) assembly – See *Chapter 2*

Enclosure The ControlWave Corrector enclosure is a standard NEMA 3R rated fiberglass enclosure. The enclosure consists of the body and the front cover. A continuous gasket seals the unit when you close the front cover. Molded channels on the cover and the body which capture a stainless steel pin form a hinge on the left side (facing the front of the unit).

The enclosure includes a weatherproof connector (local port) mounted to the bottom of the cover and connected internally to RS-232 COM port 1.

The enclosure includes a display or display/keypad for an operator or technician to view process values locally.

Internal Mounting Brackets and Battery Internal mounting brackets support the various system components, such as the battery, CPU/System Controller and Process I/O boards, and the radio/modem option. These components attach to the one piece mounting bracket which is secured to the inner rear wall of the enclosure. A factory-supplied radio or modem mounts inside the enclosure in front of the battery on a battery cover/radio mounting plate.

Radio/Modem Options You can order the ControlWave Corrector with a factory-installed modem or spread spectrum radio. The unit supports a variety of radios and modems. Contact Emerson Remote Automation Solutions for more information.

1.3 CPU/System Controller Board

The CPU (central processing unit) and System Controller Board (SCB) contains the ControlWave Corrector CPU, I/O monitor/control, memory, and communication functions.

The CPU/System Controller board includes:

- Sharp LH7A400 System-on-Chip ARM microprocessor with 32-bit ARM9TDMI Reduced Instruction Set Computer (RISC) core, with a system clock speed of either 14 MHz or 33 MHz.
- two RS-232 communication ports
- one communication port configurable by jumpers as either RS-232 or RS-485
- optional 10/100baseT Ethernet port (See *Table 1-1*)
- 2 MB of battery backed Static RAM (SRAM),
- 512KB boot/downloader FLASH,
- 8MB simultaneous read/write FLASH memory

Board Variations The CPU/System Controller board has two basic variations: `

Table 1-1. CPU/System Controller board Variations

CPU	Nominal Input Power	Ethernet Port?	Solar Regulator ?	Auxiliary Power Output?	RTD Input?
14MHz ultra low power	+6Vdc or +12Vdc	No	Yes	Yes	Yes. Connects to 100-ohm platinum bulb. Uses DIN 43760 curve.
33MHz	+12V or +24Vdc	Yes	No	No	Yes (same as ultra low power)

Note: Each of the variants shown in *Table 1-1* may be ordered with or without special gas calculation firmware.

CPU Backup Battery The CPU/System Controller board has a coin cell socket that accepts a 3.0V, 300 mA-hr lithium battery. This 3.0V battery provides backup power for the real-time clock and the system's Static RAM (SRAM).

CPU Memory There are several different types of memory used by the CPU:

Boot/Downloader FLASH

Boot/download code is contained in a single 512 Kbyte FLASH chip. Boot FLASH also holds the value of soft switches, audit/archive file configurations, and user account and port information.

FLASH Memory

The ControlWave Corrector includes 8 MB of FLASH memory. The FLASH memory holds the system firmware and the boot project. Optionally FLASH memory also stores the zipped ControlWave project (*.zwt), user files, and historical data (audit/archive files). The FLASH does not support hardware write protection.

System Memory (SRAM)

The ControlWave Corrector has 2 MB of static random access memory (SRAM). During power loss periods, SRAM enters data retention mode (powered by a backup 3.0V lithium battery). Critical system information that must be retained during power outages or when the system has been disabled for maintenance is stored here. This includes the last states of all I/O points, audit/archive historical data (if not stored in FLASH), the values of any variables marked RETAIN, the values of any variables

assigned to the static memory area, and any pending alarm messages not yet reported.

1.4 Power Options

You can power the ControlWave Corrector by:

- a factory-supplied 6V lithium battery
- a factory-supplied 6V lithium battery pack (dual 6V lithium batteries in parallel)
- a factory-supplied 6V, 7AH lead acid battery – used with a 1W, 6V solar panel system
- a factory-supplied 6V, 7AH lead acid battery – used with a 5W, 6V solar panel system
- a factory-supplied 12V, 7AH lead acid battery – used with a 5W, 12V solar panel system
- an external (user-supplied) power supply with either +5.4Vdc to +16Vdc (nominal +6Vdc), +11.4Vdc to +16Vdc (nominal +12Vdc) or +21.8Vdc to +28.0Vdc (nominal +24Vdc)

If you connect solar panels to rechargeable battery systems to power the ControlWave Corrector, there is a secondary power input you can use to provide power if there is no power from the solar panel/battery system.

1.5 I/O Options

ControlWave Corrector comes with the following standard I/O:

- 2 Pulse Counter Inputs with a 1 second scan rate (can be configured as discrete inputs (DI))

Optional I/O includes:

- Resistance Temperature Device (RTD) probe
- Gage Pressure Transducer (GPT)
- Process I/O board. Three different versions of the optional process I/O board are available. See *Table 1-2*.

Table 1-2. Process I/O Configurations

Type	Pulse Counter Inputs (PI) / Discrete Input (DI)	Discrete Input / Output (DI/DO)	Discrete Input (DI)	Discrete Output (DO)	High Speed Counter (HSC)	Analog Input (AI)	Analog Output (AO)
Standard	2						
Option 1	2	2	4	2	2		
Option 2	2	2	4	2	2	3	
Option 3	2	2	4	2	2	3	1

1.6 Software Tools

The ControlWave programming environment consists of a set of integrated software tools which allow you to create, test, implement, and download complex control strategies for use with the ControlWave Corrector. *Figure 1-1* graphically presents the programming environment.

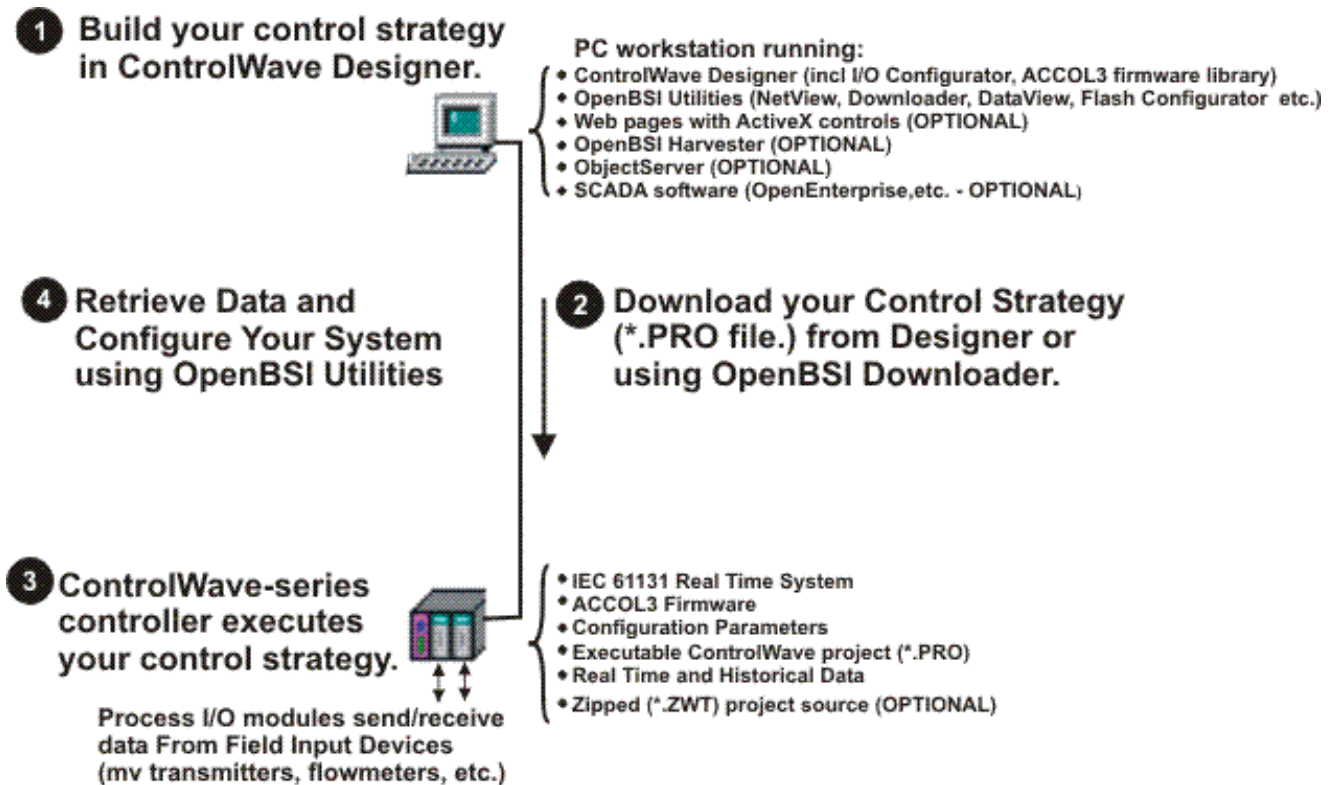

Figure 1-1. ControlWave Programming Environment

The tools which make up the programming environment include:

- **ControlWave Designer** is your load-building package. It offers several different methods for you to create control strategy programs that run in your ControlWave unit. You can use pre-made function blocks, ladder logic, or structured languages. The resulting process control strategy programs (called **projects**) are fully compatible with **IEC 61131** standards. For information on ControlWave Designer, see the *Getting Started with ControlWave Designer* manual (document D5085), and the *ControlWave Designer Programmer's Handbook* (document D5125).
- The **I/O Configurator**, accessible via a menu item in ControlWave Designer, allows you to define process I/O in the ControlWave and configure the individual mapping of I/O points for discrete and analog inputs and outputs. For information on the I/O Configurator see the *ControlWave Designer Programmer's Handbook* (document D5125).

- The **ACCOL3 Firmware Library**, available within ControlWave Designer, includes a series of ControlWave-specific function blocks. These pre-programmed function blocks let you accomplish various tasks common to most user applications including alarming, historical data storage, as well as process control algorithms such as PID control. For information on individual function blocks, see the online help within ControlWave Designer.
- **OpenBSI Utilities** provides a set of programs that allow you to configure a communication network of ControlWave controllers, download files to the controllers, and collect data from the network. OpenBSI also exports data from the network to a SCADA/host package, such as **OpenEnterprise**. For information on configuring OpenBSI communications, see the *OpenBSI Utilities Manual* (document D5081).
- **OpenBSI Harvester** is a special add-on package that allows scheduled data collections from large networks. For information on the Harvester, see the *OpenBSI Harvester Manual* (document D5120).
- A series of **web page controls** are available for retrieval of real-time data values and communication statistics. These controls utilize ActiveX technology and are called through a set of fixed web pages, compatible with Microsoft® Internet Explorer. (See the *ControlWave Flow Measurement Applications Guide D5137*) Alternatively, developers can place the controls in third-party ActiveX compatible containers such as Visual BASIC or Microsoft® Excel. For information on the ActiveX controls, see the *Web_BSI Manual* (document D5087).
- **User-defined web pages** - If desired, you can use the ActiveX web controls in your own user-defined web pages you can store at the PC to provide a customized human-machine interface (HMI).
- **Flash Configuration Utility** – Parameters such as the BSAP local address, IP address, etc. are set using the Flash Configuration Utility, accessible via OpenBSI LocalView, NetView, or TechView. For information on the Flash Configuration Utility, see *Chapter 5* of the *OpenBSI Utilities Manual* (document D5081).

Communication Protocols In addition to the **Bristol Synchronous/Asynchronous Protocol (BSAP)**, ControlWave supports communications using:

Internet Protocol (IP) - You can use an Ethernet port or use a serial port with serial IP using **Point-to-Point Protocol (PPP)**.

Other supported protocols include: Modbus, Allen-Bradley DF1, CIP, DNP3, and Hex Repeater. See the ControlWave Designer online help for details and restrictions.

1.7 Overview of the Gas Flow Measurement Application

Note: For detailed information on the gas flow measurement application and web pages refer to the *ControlWave Flow Measurement Applications Guide* (D5137).

You can purchase the ControlWave Corrector with a pre-programmed flow measurement application already loaded.

The ControlWave standard gas flow measurement application collects static pressure, differential pressure and temperature data and computes flow, energy, and volume for a station.

A **station** typically refers to a single flow computer and all its associated meter runs. Each **meter run** refers to measurement of natural gas through a single pipeline.

1.7.1 Data Acquisition – Static Pressure, Differential Pressure, Temperature Variables

The application requires these process inputs for orifice measurement:

- static pressure (SP) collected once per second
- differential pressure (DP) collected once per second
- flowing temperature (T) collected once per second

The application requires these process inputs for measurement using a positive displacement (PD), turbine, or ultrasonic meter:

- static pressure (SP) collected once per second
- frequency input collected once per second
- flowing temperature (T) collected once per second

The application also collects self-test and compensation variables at intervals of four seconds or less.

Pressure data can come from any of the following sources:

- Analog pressure transmitters connected to analog input points on a process I/O module in the ControlWave flow computer.
- Built-in gage pressure transducer.
- External multivariable transmitters (Bristol or Rosemount) using BSAP or Modbus communications through an RS-485 communication port.

1.7.2 Flow and Volume Calculations

Flow and volume calculations conform to American Petroleum Institute (API) and American Gas Association (AGA) standards.

Supported flow calculations include:

- AGA3-1985/NX-19
- AGA3-1992 with selectable AGA8 Gross or AGA8 Detail
- AGA7/NX-19

- AGA7 with selectable AGA8 Gross or AGA8 Detail
- Auto-adjust AGA7/NX-19
- Auto-adjust AGA7 with selectable AGA8 Gross or AGA8 Detail

The application performs a complete flow calculation using the process variables every second. Each calculation includes instantaneous rate according to API 14.3, compressibility according to AGA 8 Detail or Gross method, and updates of all volumes, totals, and archive averages.

1.7.3 Flow Rate and Flow Time Calculations (AGA3)

For orifice flow measurement, the application compares the differential pressure value to a low flow cutoff value every second. If the differential pressure falls below the low flow cutoff value, flow is considered to be zero for that second. Hourly and daily flow time is defined to be the number of seconds for which the differential pressure exceeded the cutoff value for the period.

The values for static and differential pressure and temperature are used as inputs to the flow equations. You can select API 14.3 (AGA3, 1992) and AGA8 calculations, with compressibility calculations according to AGA Report No. 8, 1992 (with 1993 errata). The application supports both the detail method and the two gross methods of characterization described in AGA 8. Users may also select the AGA3, 1995 and NX-19 flow equations to calculate the rate of flow.

1.7.4 Flow Rate and Flow Time Calculations (AGA7)

When using PD meters, turbine meters or ultrasonic meters, the application calculates flow rate by applying the correction factor computed by the AGA7 calculations to the frequency of the input pulses. When the frequency drops below 1 Hz, the application sets the flow rate estimate to zero; however, volume calculations still accumulate. The flow time recorded is the time for which the flow rate is non-zero.

1.7.5 Extension Calculation and Analog Averaging

For orifice meters, the application calculates the flow extension every second. The extension is the square root of the product of the absolute upstream static pressure times the differential pressure. This extension is used in the flow rate calculation. When there is no flow, the application reports the arithmetic averages of static pressure and temperature. This allows you to monitor static pressure and temperature during shut-in periods.

1.7.6 Energy Calculation

The application offers the option of using a fixed volumetric heating value or calculating the energy content of the gas according to AGA Report No. 5.

1.7.7 Volume and Energy Integration

The application integrates and accumulates volume and energy at the end of every calculation cycle. The application calculates the volume for a cycle by multiplying the calculated rate by the flow time for that cycle. The application calculates the energy for a cycle by multiplying the volume at base conditions by the heating value.

1.7.8 Historical Data Storage (Audit Records/ Archive Files)

The ControlWave supports two distinct types of historical data storage – audit records and archive files.

Where feasible, both forms of archive data conform to the requirements of the API Chapter 21. Specifically, the averages of the process variables stored in the data archive are for flowing periods, appropriate to their usage in the equations, and any gas-related parameter designated an event that is changed by an operator either remotely or locally causes an entry in the audit log.

Audit Records (Alarms and Events)

The audit system maintains a history of alarms and certain events that have an impact on the calculated and reported gas flow rates and volumes.

The application stores the most recent 500 alarms and the most recent 500 events. As new alarms/events arrive, they overwrite the oldest entries. Internally, the application stores alarms and events separately to prevent recurring alarms from overwriting configuration audit data events. The application reports alarms and events in the same log.

The following circumstances generate an audit record:

- Any operator change to a configuration variable
- Any change in the state of an alarm variable
- A system restart
- Certain other system events

You can view audit records on-screen in the audit log.

See the *Appendix K* of the *OpenBSI Utilities Manual (D5081)* for help on interpreting audit records.

Archive Files (Averages, totals, and other values) Archive files store the value of process variables and other calculated variables at specified intervals along with the date and time of each entry. This includes flow rates, volumes and other calculated values. When archive files fill up, new values overwrite the oldest entries in the files.

The application displays archive file data in hourly, data, and periodic logs you can view on screen.

Log Breaks

You can configure the application to support the "breaking" of a log period when an operator-changes a parameter. When this occurs, the log period in process closes out to make a log, and a new log begins.

Note: To prevent several very short logs from being created due to a series of successive configuration changes, the application will not create a log which contains less than 60 seconds (flowing or otherwise) of data. Therefore if you enter 15 configuration changes over a 2-minute period, the log will only breaks twice.

Hourly Historical Data Log

Each meter run maintains an hourly data log that holds one record for every contract hour. Hourly logs hold 840 entries or 35 days; this ensures that the previous period of hourly data is always resident in flash memory.

The hourly data log stores the following items:

- corrected volume
- uncorrected volume
- accumulated energy
- average static pressure
- average temperature
- average differential pressure
- average specific gravity
- average heating value
- flow time
- uncorrected count

Daily Historical Data Log

Each meter run maintains a daily data log that holds one record for every contract gas day. You can change the contract hour if the contract gas day starts at some time other than midnight. The daily log holds 62 entries; this ensures that the previous calendar month of daily data is always resident in flash memory.

The daily data log stores the following items:

- corrected volume
- uncorrected volume
- accumulated energy
- average static pressure
- average temperature
- average differential pressure
- average specific gravity
- average heating value
- flow time
- uncorrected count

Periodic Historical Data Log

Each meter run maintains a periodic data log that holds one record for every log interval. Each log interval is 15 minutes. The periodic historical data log holds 1440 records, or four days of 15 minute data.

The periodic historical data log stores the following items:

- flowing differential pressure
- flowing static pressure
- flowing temperature
- frequency

1.7.9 Run Switching

If you use multiple meter runs in the application, you can configure run switching. Run switching (also known as meter run staging or tube switching) allows changes to the number of meter runs currently active to meet the gas flow demand for the station.

1.7.10 Sampler and Odorizer

Samplers are external devices which measure the quality of the gas stream.

Because natural gas is odorless and colorless, devices called odorizers inject an additive to the gas stream that allows people to detect the presence of natural gas in the event of a gas leak.

1.7.11 Chromatograph Interface

If you use a chromatograph to measure gas component information you can integrate this into the application. You can also specify fixed gas component percentages to use if the chromatograph fails.

1.7.12 Nominations

Nominations allow you to configure the ControlWave flow computer to allocate precise amounts of gas flow during specific time periods, called nomination periods.

This page is intentionally left blank

Chapter 2 – Installation

This chapter discusses the physical configuration of the ControlWave Corrector, considerations for installation, and instructions for setting switches and jumpers.

In This Chapter

2.1	Site Considerations.....	2-1
2.1.1	Class I, Div 2 Installation Considerations.....	2-3
2.2	Installation Overview.....	2-4
2.3	Unpacking Components	2-5
2.4	Mounting the ControlWave Corrector Assembly	2-5
2.4.1	Configuring the TeleCounter Assembly	2-13
2.4.2	Configuring the ISPROX Module (Option)	2-13
2.4.3	Connection to the Gage Pressure Transducer (GPT)	2-14
2.4.4	Grounding the Housing	2-17
2.5	Configuring the CPU/System Controller Board	2-18
2.5.1	Setting DIP Switches on the CPU/System Controller Bd...2-19	
2.5.2	Setting Jumpers on the CPU/System Controller Board	2-21
2.5.3	General Wiring Guidelines	2-22
2.5.4	Wiring Power to the CPU/System Controller Board.....	2-23
2.5.5	Connections to RS-232 Serial Port(s) on the CPU/System Controller Board.....	2-25
2.5.6	Connections to the COM3 (RS-485/RS-232) Serial Port on the CPU/System Controller Board.....	2-30
2.5.7	Connections to the Ethernet Port on the CPU/System Controller Board	2-32
2.6	Radio-Ready and Case Mounted Modem or Radio	2-33
2.7	Mounting the Solar Panel	2-34
2.8	Optional Display/Keypads.....	2-37

2.1 Site Considerations

When choosing an installation site, check all clearances for the enclosure, for the attached GPT, for the optional RTD probe, for the TeleCounter assembly, and if applicable, for the solar panel. Ensure that you can open the front cover of the ControlWave Corrector (hinged on the left side) for wiring and service. Make sure the display/keypad is accessible and visible.

See *Figure 2-9* for a dimensional drawing of the NEMA 3R enclosure with a GPT and TeleCounter. See *Figure 2-10* for a dimensional drawing of the NEMA 3R enclosure with a GPT and no TeleCounter.

The ControlWave Corrector is designed to operate in a Class I Division 2, Groups A, B, C & D environment with a nonincendive rating (see *Appendix A*). The ControlWave Corrector can operate in an unprotected outdoor environment.

Caution

To ensure safe use of this product, please review and follow the instructions in the following supplemental documentation:

- Supplement Guide - ControlWave Site Considerations for Equipment Installation, Grounding, and Wiring (S1400CW)
- ESDS Manual – Care and Handling of PC Boards and ESD Sensitive Components (S14006)

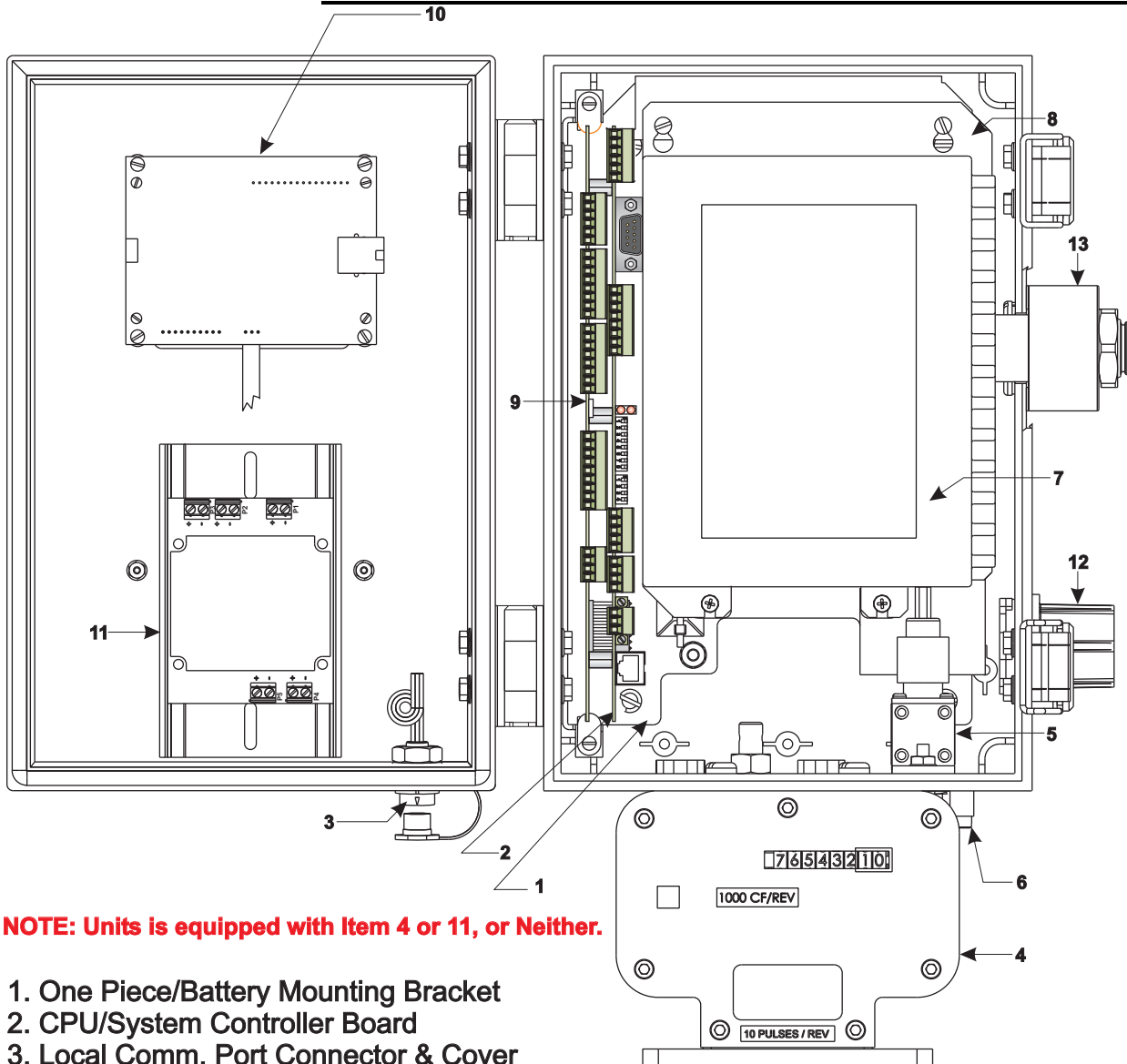

NOTE: Units is equipped with Item 4 or 11, or Neither.

- | | |
|---|--|
| 1. One Piece/Battery Mounting Bracket | 9. Optional Process I/O Board |
| 2. CPU/System Controller Board | 10. Optional Dual-Button Display/Keypad Ass'y. |
| 3. Local Comm. Port Connector & Cover | 11. Optional ISProx Module |
| 4. Optional TeleCounter Assembly | 12. 3/4" Conduit Fitting |
| 5. Optional Polyphaser | 13. Smart, Gage Pressure Sensor |
| 6. Ground Lug | |
| 7. Optional External Radio (MDS - Transnet) | |
| 8. Radio/Modem Mounting Bracket | |

Figure 2-1. ControlWave Corrector (with MDS - Transnet Radio) (Internal View) Component Identification Diagram

**Specifications
for Temperature,
Humidity and
Vibration**

- See document [1665DS2c](#) available on our website for detailed technical specifications for temperature, humidity, and vibration for the ControlWave Corrector.
- Ensure that the ambient temperature and humidity at the installation site remains within these specifications. Operation beyond the specified ranges could cause output errors and erratic performance. Prolonged operation under extreme conditions could also result in failure of the unit.
- Check the mounted enclosure, panel, or equipment rack for mechanical vibrations. Make sure that the ControlWave Corrector is not exposed to a level of vibration that exceeds that provided in the technical specifications.

2.1.1 Class I, Div 2 Installation Considerations

Underwriters Laboratories (UL) lists the ControlWave Corrector as non-incendive and suitable **only** for use in Class I, Division 2, Groups A, B, C, and D hazardous locations and non-hazardous locations. Read this chapter and *Appendix A* carefully before you install a ControlWave Corrector in a hazardous location.

Perform all power and I/O wiring in accordance with Class I, Division 2 wiring methods as defined in *Article 501-4 (b)* of the *National Electrical Code, NFPA 70* (for installations within the United States) or as specified in *Section 18-152* of the *Canadian Electrical Code* (for installation in Canada).

**WARNING****EXPLOSION HAZARD**

Substitution of components may impair suitability for use in Class I, Division 2 Group A, B, C and D environments.

When the ControlWave Corrector is situated in a hazardous location, turn off power before servicing or replacing the unit and before installing or removing I/O wiring.

Do not disconnect equipment unless the power is switched off or the area is known to be non-hazardous.

2.2 Installation Overview

Installing a ControlWave Corrector involves several general steps:

1. Unpacking, assembling, and configuring the hardware. This includes:
 - a) Mounting the enclosure on site. (See *Section 2.4*)
 - b) Removing the CPU/System Controller board and optional Process I/O board assembly so you can enable the backup battery by setting jumper W3 on the CPU/System Controller board to position 1 to 2. See *Section 5.2.2* for instructions on removing/replacing the board assembly, see *Section 2.5.2* for information on setting jumpers.
 - b) Setting other switches and jumpers on the CPU/System Controller board (see *Section 2.5.1* and *Section 2.5.2*) and on the Process I/O board (see *Section 3.2.1* and *Section 3.2.2*) and placing both boards (as a single assembly) back into the chassis.
 - d) Connecting communication cables. (See *Sections 2.5.5, 2.5.6, and 2.5.7*)
 - e) Wiring I/O. (See *Section 3.3*)
 - f) Connecting an external 3808 transmitter (see *Section 3.3.8* if required).
 - f) Installing a ground wire between the enclosure's ground lug and a known good Earth ground. (See *Section 2.4.4*)
 - h) Connecting the RTD probe (if required). (See *Section 3.3.7*)
 - g) Installing the solar panel (See *Section 2.7*) and rechargeable battery (See *Section 2.5.4* if applicable)
 - i) Wiring power to the unit. (See *Section 2.5.4*)
 - j) Turning on power. (See *Section 4.1*)
2. Installing PC-based software (TechView).
3. Establishing communications to perform calibration activities or view data using the standard flow measurement application menus.

Note: Steps 2 through 3 require that you install and use OpenBSI TechView software to perform calibration and that you use the standard menus. This manual focuses on hardware installation and preparation. Software installation and configuration is beyond the scope of this manual. Refer to the *TechView User's Guide* (D5131) and the *ControlWave Flow Measurement Applications Guide* (D5137) for more information. If you are **not** using the flow measurement application and plan to create your own application, refer to the *Getting Started with ControlWave Designer Manual* (D5085) and the *ControlWave Designer Programmer's Handbook* (D5125).

2.3 Unpacking Components

Packaging ControlWave Corrector units ship from the factory with all components wired and mounted except for the unit's solar panel and battery; these items are shipped separately.

2.4 Mounting the ControlWave Corrector Assembly

- You must position the ControlWave Corrector vertically. Units equipped with the TeleCounter (Pulser) assembly mount directly to a turbine meter. Units that do not have the optional TeleCounter assembly can be mounted remotely to a panel or wall or to a vertical 2" pipe (clamped at the rear of the unit via two clamps and four bolts – see *Figure 2-4* and *Figure 2-6*). If used, the 2" pipe must be anchored in cement (deep enough to conform to local building codes associated with frost and support considerations).
- See *Figure 2-9* for a dimensional drawing of the NEMA 3R enclosure with a GPT and TeleCounter. See *Figure 2-10* for a dimensional drawing of the NEMA 3R enclosure with a GPT and no TeleCounter.
- Position the unit so that the front of the unit is both visible and accessible for service, i.e., installing an option or replacement of the battery, or installation/removal of any ControlWave Corrector module. Make sure the operator can see and access the keypad/display.
- You must allow clearance space for the optional Solar Panel (if required).
- The TeleCounter bolts to a turbine meter (via four nuts at the base of the TeleCounter) (see *Figure 2-2*); the turbine meter, in-turn, connects to the main (meter run). A gasket is required between the TeleCounter assembly and the top of the turbine meter (see *Figure 2-3*). When mating the ControlWave Corrector to the turbine meter, it is essential that the TeleCounter input shaft and the opening on the turbine meter output shaft mate properly. Be careful not to damage

the mating surfaces. Once the surfaces align, install and secure the mounting washers and nuts. Be aware that the meter interface (TeleCounter base plate) has an eight-bolt mounting pattern. The bolt patterns allow the ControlWave Corrector to be mounted in two positions that are 180° apart. The meter interface mounting hole locations illustrated in *Figure 2-3* accommodate the flow meters listed in *Table 2-1*.

Table 2-1. Flow Meter Mounting Position

Manufacturer	Mounting Position	Hole Pattern	Notes
American Meter, Root & Romet	Forward mount	A	The base plate can be rotated in 90° increments. For reverse mounting, remove the base plate screws (see <i>Figure 2-3</i> hole locations "D") and rotate the base plate 180°.
Rockwell	Forward mount	B	The base plate can be rotated in 90° increments.
Rockwell	Reverse mount	C	The base plate can be rotated in 90° increments.

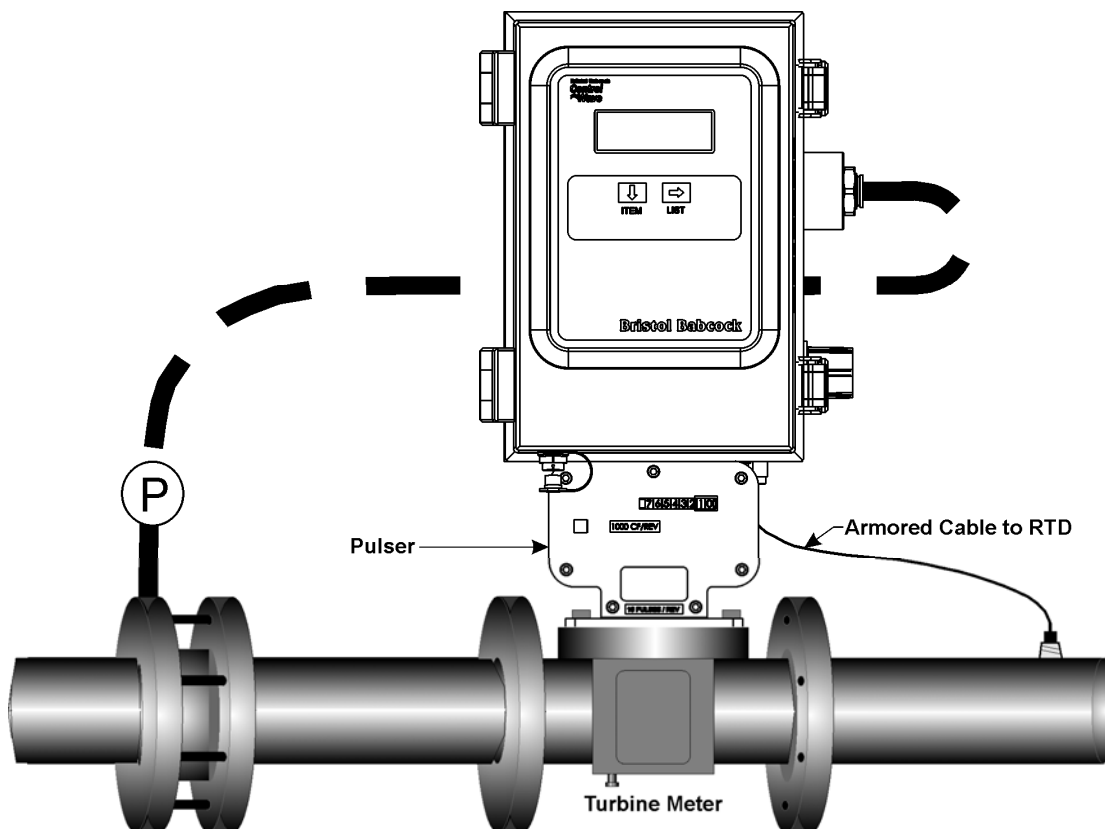
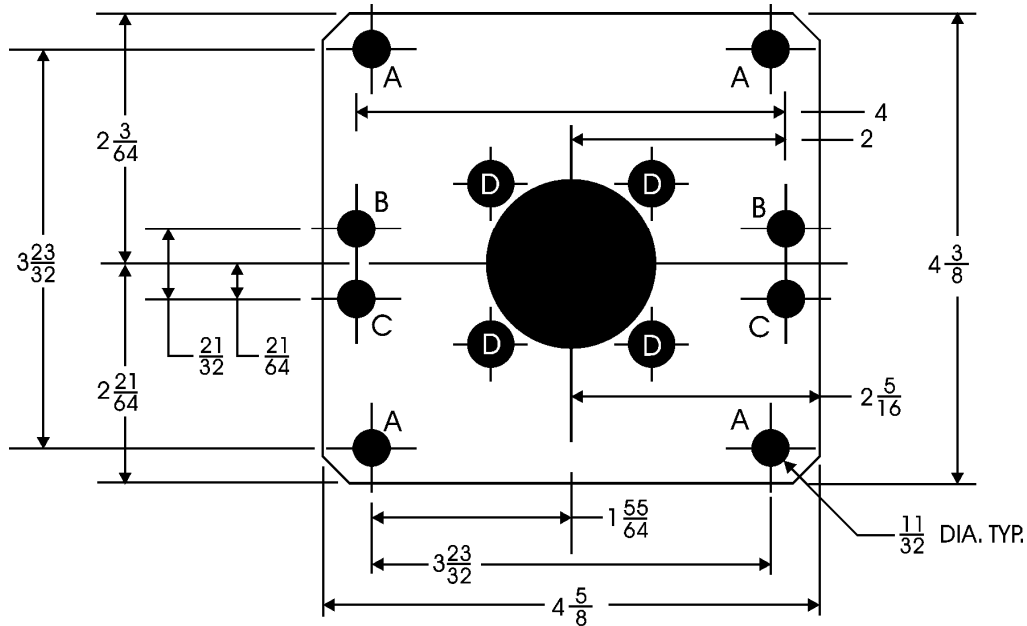

Figure 2-2. ControlWave Corrector Mounted to Turbine Meter



Note: Holes labeled 'D' are for Base Plate mounting.

Figure 2-3. ControlWave Corrector/Meter Interface Mounting Hole Pattern (Dimensions are in Inches)

Power wiring should not be installed until the unit has been mounted and grounded at a designated work site. External power wiring, RTD cabling, local comm. port, antenna cable, and network (RS-232 and RS-485) comm. port cabling enter the bottom of the unit through conduit or special function fittings. I/O wiring is routed through the left side of the unit (right when facing the front) via a .75" Conduit Fitting.

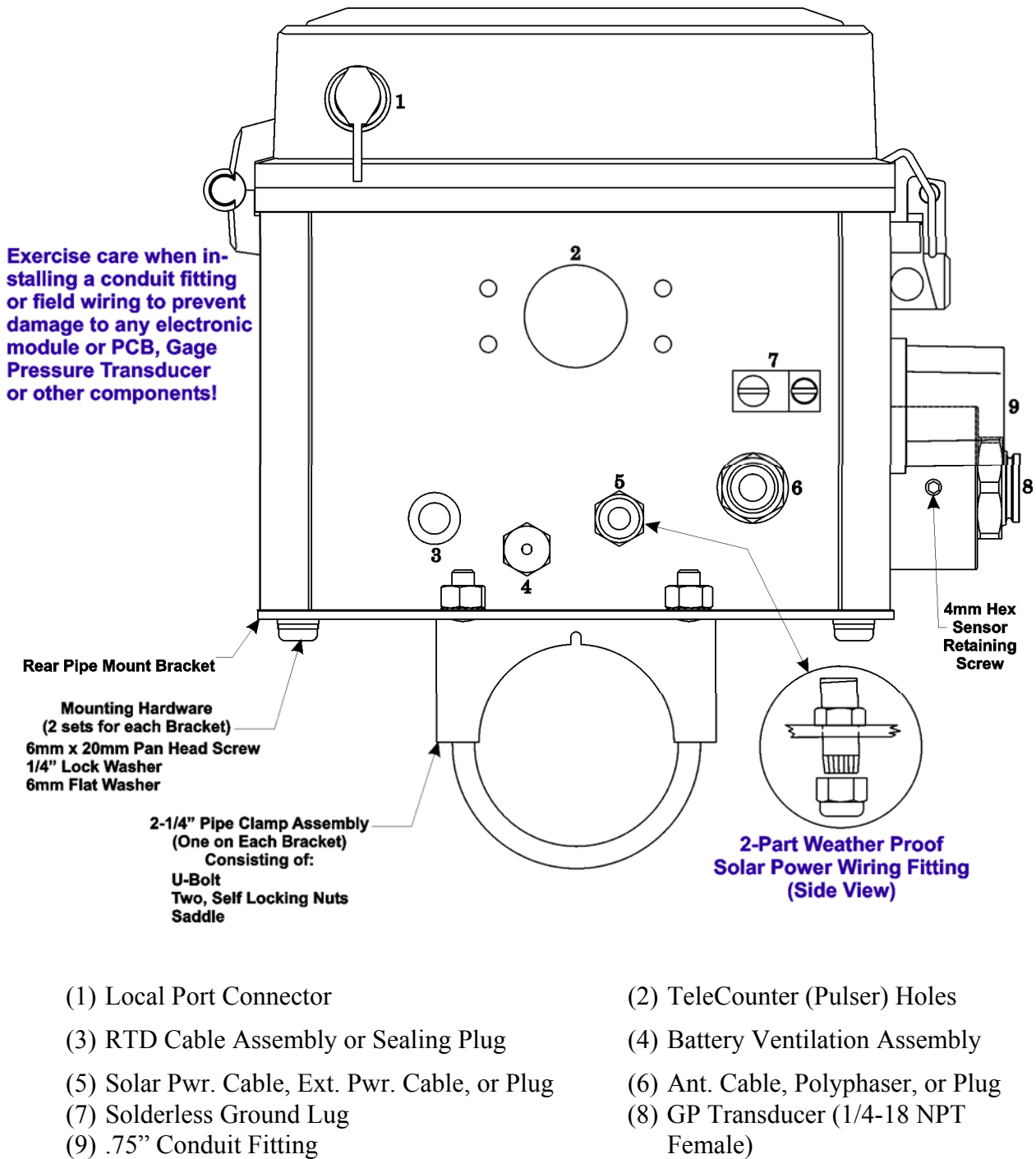

Figure 2-4. ControlWave Corrector Bottom View

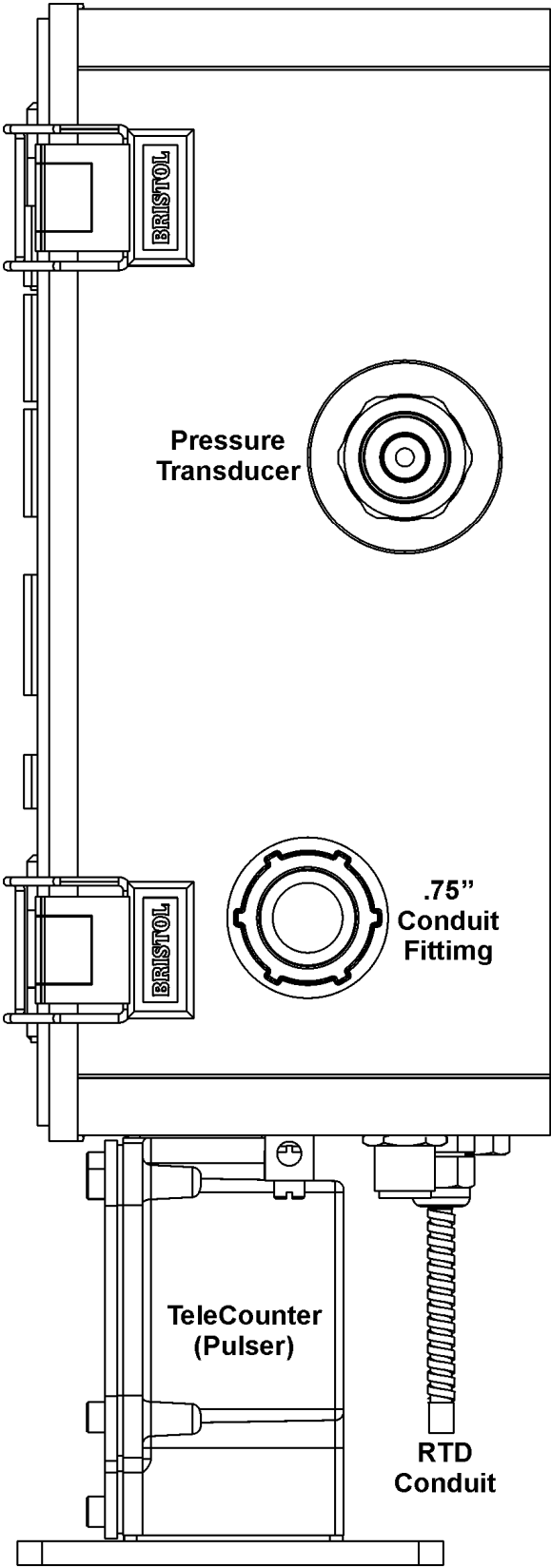

Figure 2-5. Side View of ControlWave Corrector (with TeleCounter)

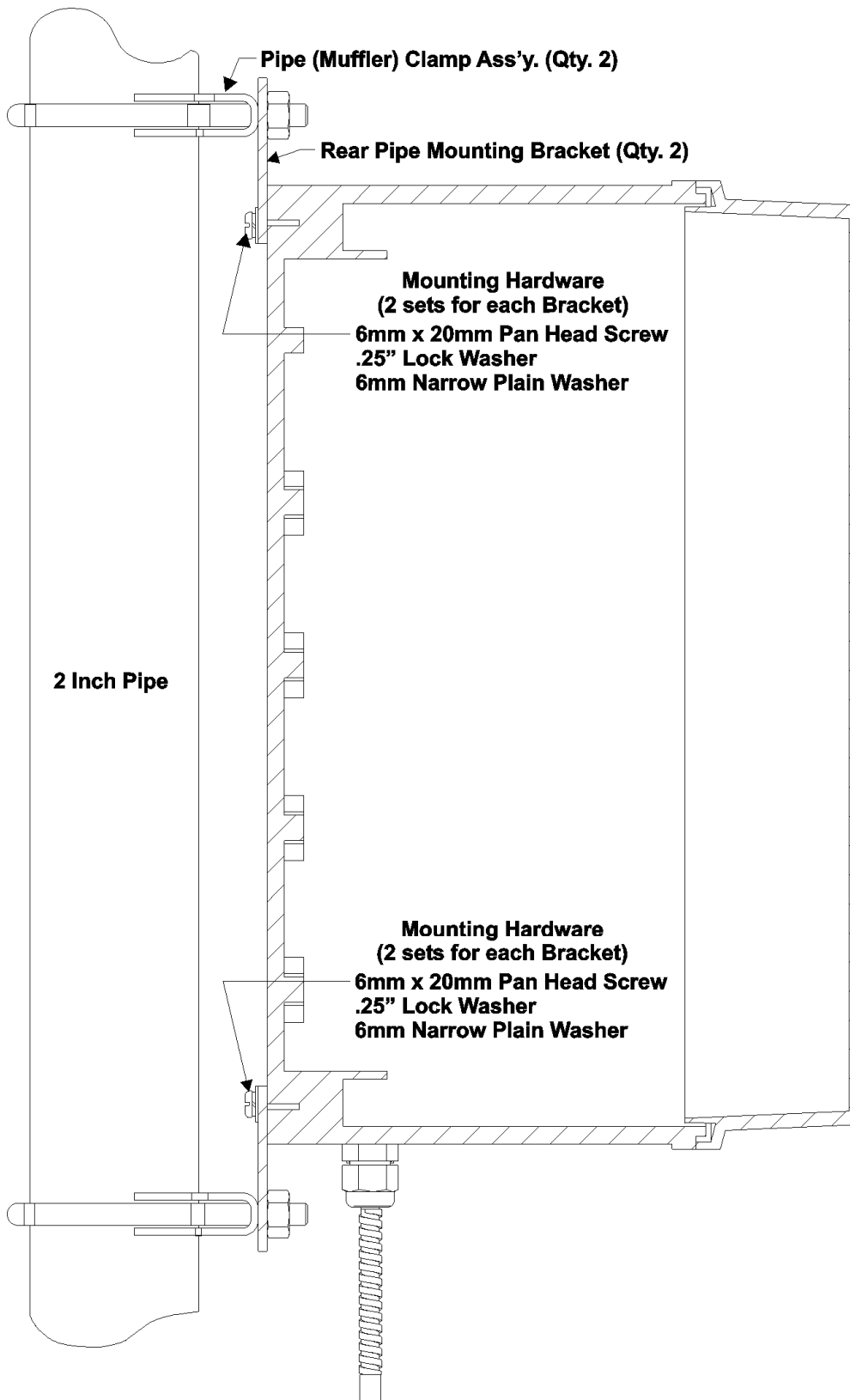
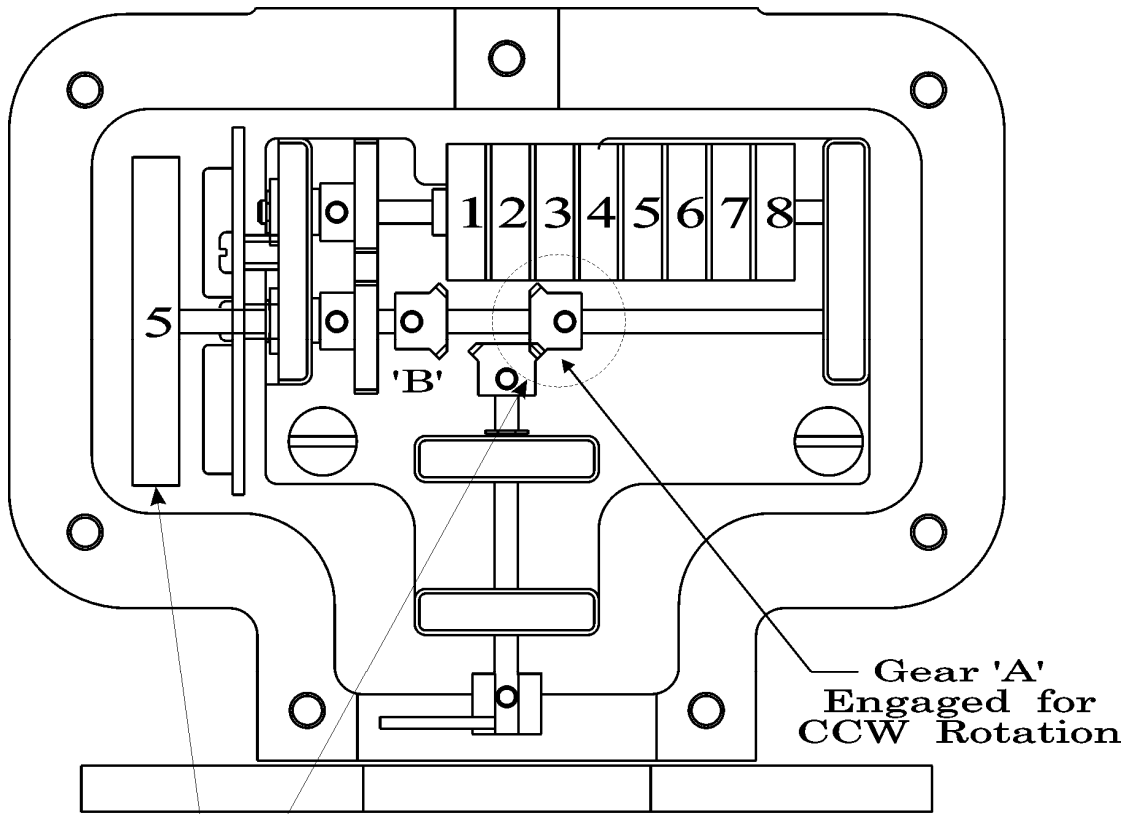

Figure 2-6. Side View of ControlWave Corrector (without TeleCounter)- (Pipe Mounted)



Gear 'A'
Engaged for
CCW Rotation

1 to 1 Gear Ratio
1-Magnet Magnet Wheel
Produces 1 Count per Revolution

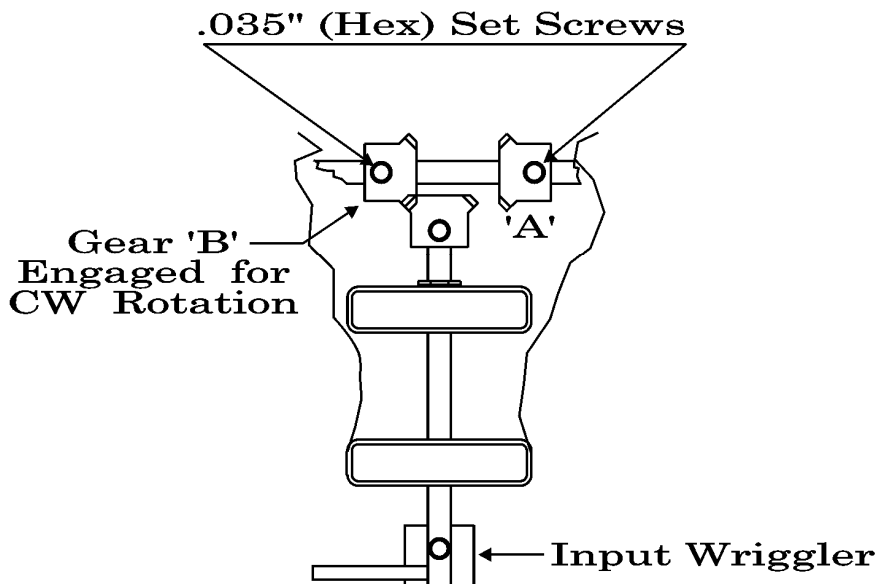

Figure 2-7. TeleCounter Assembly (1 to 1 Gear Ratio) Rotation Adjust Diagram

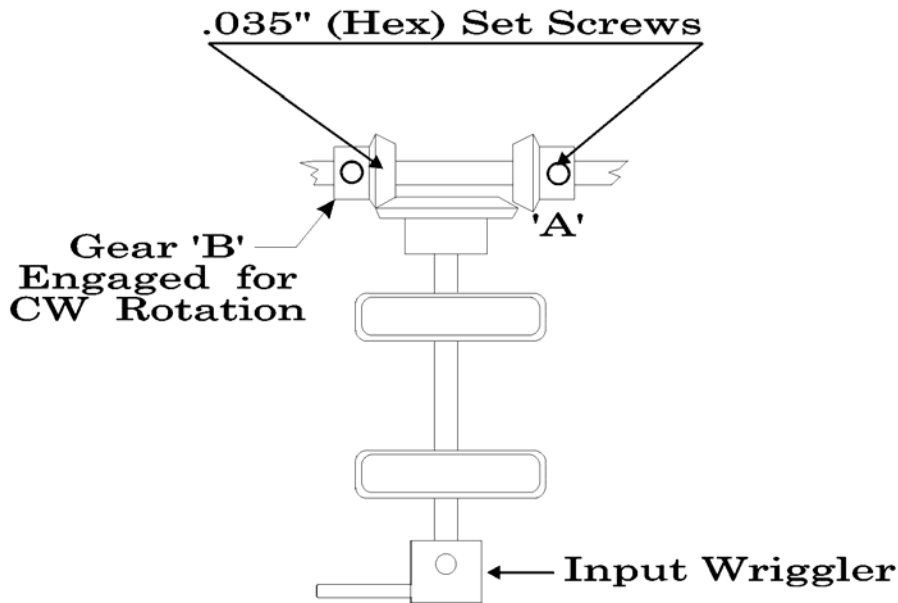
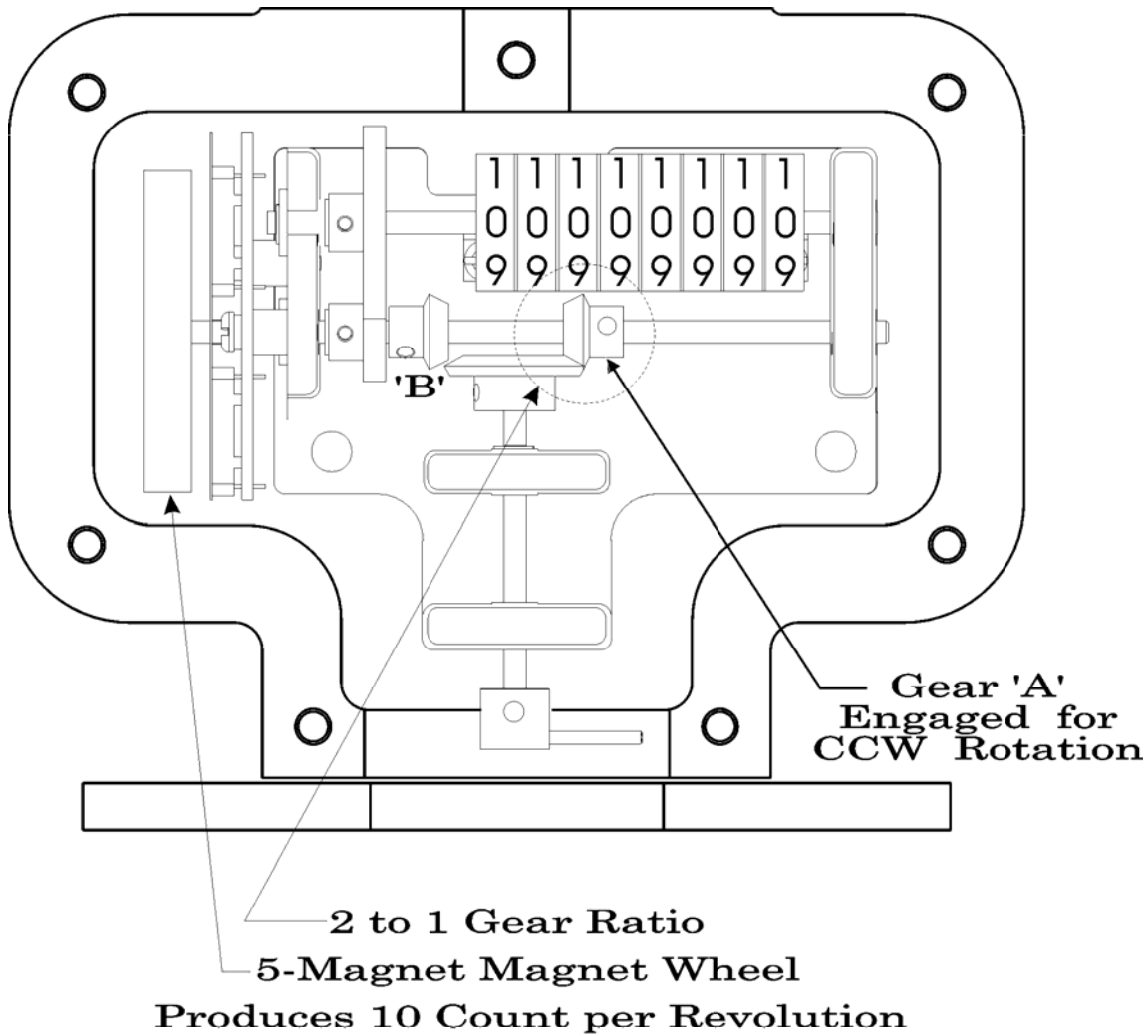

Figure 2-8. TeleCounter Assembly (2 to 1 Gear Ratio) Rotation Adjust Diagram

2.4.1 Configuring the TeleCounter Assembly

When present, the TeleCounter Assembly (Pulser) is situated below the enclosure and is mounted to the bottom of the unit with a gasket water tight seal. The Pulser is secured to the enclosure with four screws. The Pulser can be opened in the field to set its gears for proper rotation, i.e., so that the counter is increasing. The 8 digit odometer provides a count of 0000000.0 to 9999999.9 revolutions. The magnet wheel and the odometer's tenths wheel will increment 10 digits each time the turbine meter completes one revolution.

Rotation of the TeleCounter Magnet Wheel and Odometer

The TeleCounter can be configured to accept a clockwise or counterclockwise turbine meter shaft rotation. Two sets of gears in the TeleCounter assembly accommodate configuration of the ControlWave Corrector. These gears are factory set (per order) but may be field configured as required. The following steps are required to reconfigure the TeleCounter gears:

1. Remove the seven (7) screws which secure the face plate to the front of the TeleCounter assembly,
2. Using a .035" Hex wrench, loosen the set screw associated with drive gear 'A' (CCW) or 'B' (CW) and slide this gear to its resting position. Tighten the drive gear's set screw (see *Figure 2-7* and *Figure 2-8*).
3. Loosen the .035 Hex set screw which secures the other drive gear "A" or "B" and slide this gear until it engages the main drive gear. Tighten the drive gear's set screw. Check for binding by rotating the Input Wiggler.
4. Replace the face plate securing it with the seven (7) screws removed in step 1.

2.4.2 Configuring the ISPROX Module (Option)

When present, an ISPRox Module Board will reside on the inside of the front cover. ISProx boards provide an interface to one or two industry standard variable impedance proximity sensors (NAMUR gap sensors) and conditions and converts these signals to either open drain outputs (DOs) which in turn drive the ControlWave Corrector's pulse inputs on the CPU/System Controller board. ISProx Modules are discussed in document *PIP-CW ISProx*.

2.4.3 Connection to the Gage Pressure Transducer (GPT)

One optional Gage Pressure Transducer (GPT) secured to the right side of the enclosure (facing the front of the unit) can be provided with each ControlWave Corrector. Gage pressure transducers are equipped with a 1/4-18 NPT female pipe fitting (see *Figure 2-4* and *Figure 2-5*).

You can mount units with a GPT remotely to a panel, a wall, or to a vertical 2 inch pipe clamped at the rear of the unit using the two mounting brackets with two clamps and four bolts.

You can only connect the gage pressure transducer via tubing. Within the body of the transducer, metal diaphragms are exposed to the gas. Solid-state strain gauge sensors in the neck of the transducer measure the pressure applied to the diaphragms and produce proportional electrical signals.

The neck of the GPT extends into the side of the enclosure, with the body of the transducer outside the enclosure. The GPT cable connector is factory mated with the CPU/System Controller board connector P1.



You cannot mount units with a GPT directly to the main (meter run).

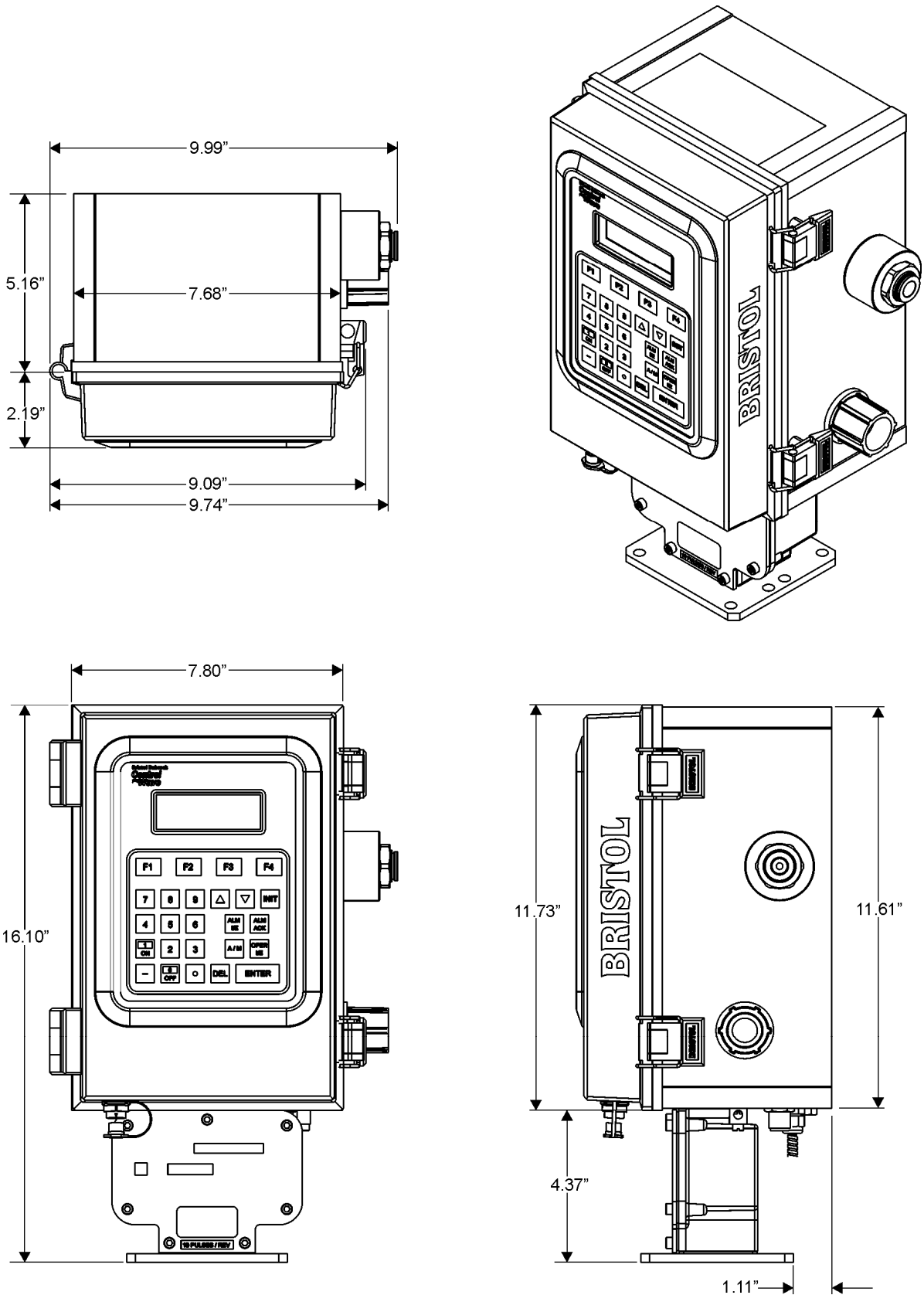

Figure 2-9. ControlWave Corrector (with TeleCounter & GPT) - NEMA 3R Enclosure Dimensions

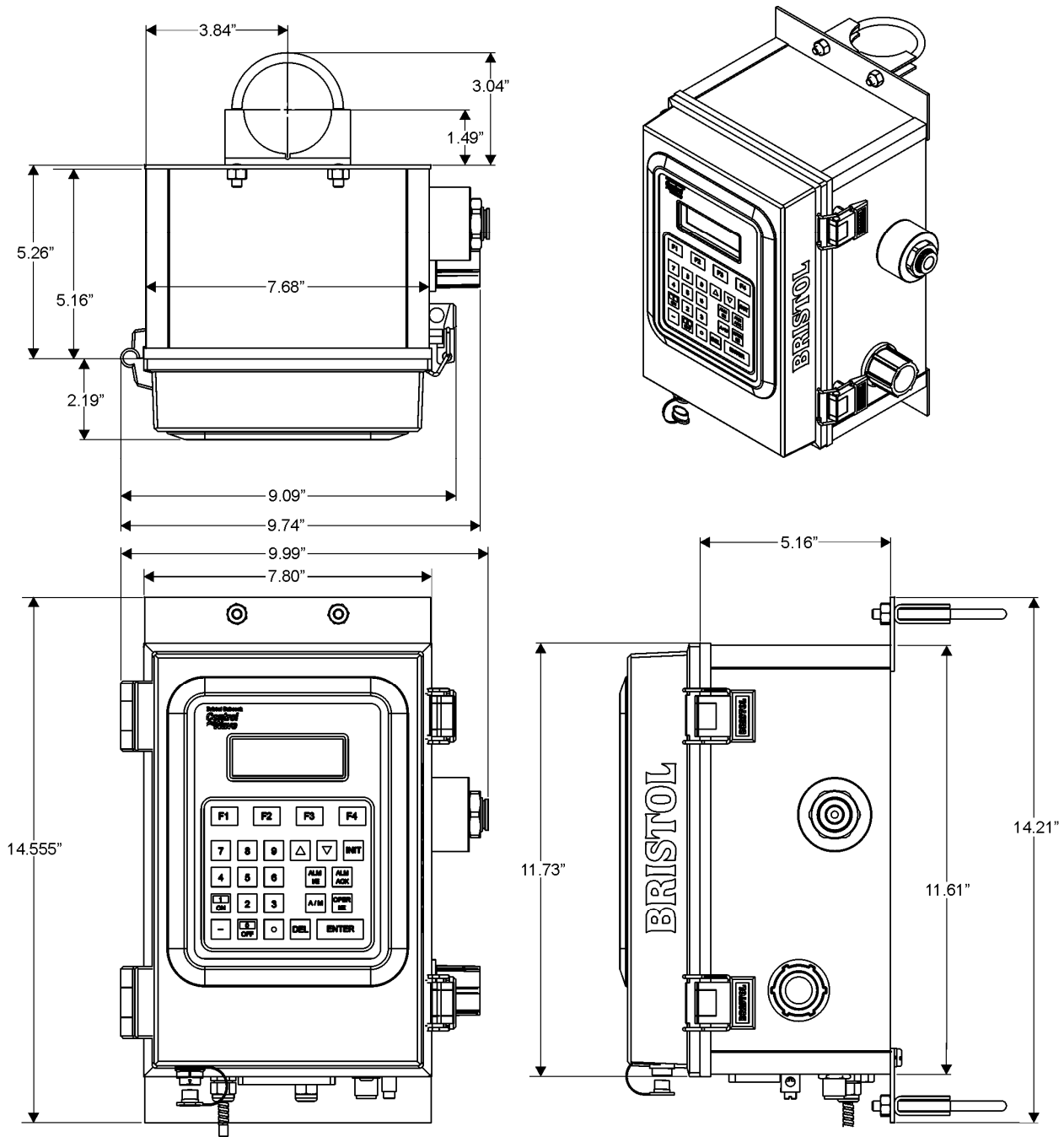

Figure 2-10. ControlWave Corrector (with GPT - without TeleCounter) NEMA 3R Enclosure Dimensions

2.4.4 Grounding the Housing

The ControlWave Corrector enclosure includes a ground lug. If your unit has a GPT, see *Figure 2-4* to locate the ground lug. Once you have installed the unit, run a ground wire (#4 AWG max wire size) between the ground lug and a known good earth ground. Connect the cases of temperature transducers, pressure transmitters, and so on to the known good earth ground. For more information on grounding see the *ControlWave Grounding Supplement (S1400CW)*:

Additional grounding guidelines include:

- Use stranded copper wire (#4 AWG) to earth ground, and keep the length as short as possible.
- Clamp or braze the ground wire to the ground bed conductor (typically a stranded copper AWG 0000 cable installed vertically or horizontally).
- Using a high-wattage soldering iron, tin the wire ends with solder before you insert them into the chassis ground lug.
- Run the ground wire so that any routing bend in the cable has a minimum radius of 12-inches below ground and 8-inches above ground.

2.5 Configuring the CPU/System Controller Board

The CPU/System Controller board mounts vertically on edge inside the enclosure on the right side of the Process I/O board. To configure the CPU/System Controller board, you need to set some switches and jumpers.

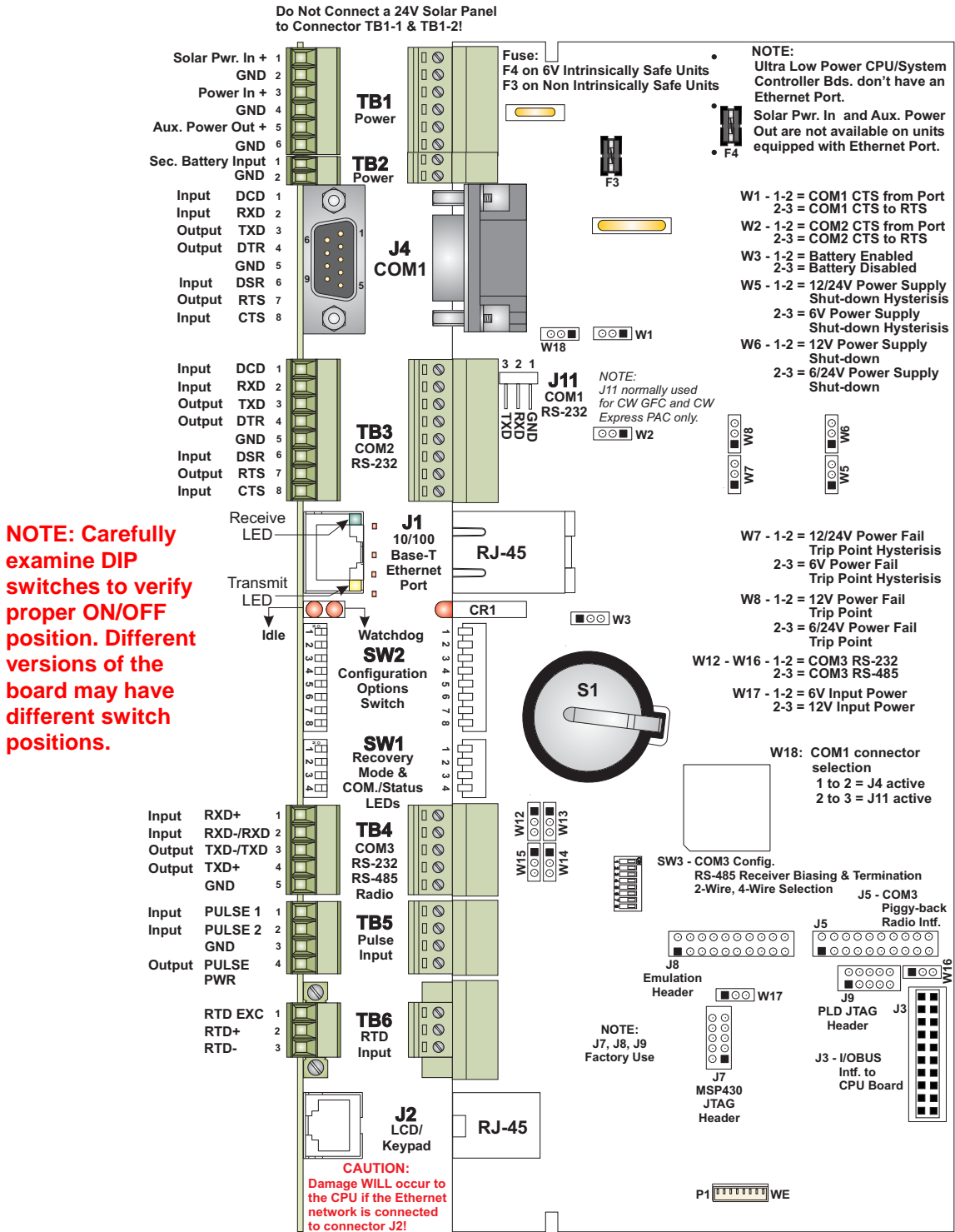

Figure 2-11. - CPU/System Controller Board Component I.D. Diagram

2.5.1 Setting DIP Switches on the CPU/System Controller Board

Before you install the CPU/System Controller board, you must determine the settings for three banks of DIP switches. Refer to *Figure 2-11* for the location of the DIP switch banks. Refer to *Tables 2-2, 2-3, and 2-4* for an explanation of the DIP switch positions.

Notes:

- Examine each bank of DIP switches carefully to note the switch direction for ON or OFF. Different versions of the board may use different switch positions.
- Only switch combinations described have been tested.

Table 2-2. CPU/System Controller Board Switch SW1

SW1 Setting	Function	Mode
1 & 2	Recovery Mode	Recovery Mode = Both SW1-1 and SW1-2 ON or both SW1-1 and SW1-2 OFF Local Mode = SW1-1 OFF and SW1-2 ON (Factory Default)
3	Force Recovery Mode	Enables recovery mode. Values are: ON (enables recovery mode) OFF (disables recovery mode). – This is the factory default .
4	LED status	ON (Enable IDLE LED status indication) OFF (Disable IDLE LED status indication)

Table 2-3. CPU/System Controller Board Switch SW2

SW2 Setting	Function	Mode
1	Watchdog Enable	Controls whether the system enters a watchdog state when a crash or system hang-up occurs and automatically restarts. Values are: ON (Enables watchdog circuit; factory default) OFF (Disables watchdog circuit and prevents automatic restart)
2	Lock/Unlock Soft Switches	Controls the ability to modify soft switches, other configurations, and flash files. Values are: ON (Unlocks soft switches and flash files; factory default). OFF (Locks soft switches, configurations, and flash files)
3	Use/Ignore Soft Switches	Controls the use of soft switches. Values are: ON (Enable user-defined soft switches configured in flash memory; factory default) OFF (Disable soft switch configuration and use factory defaults) Note: Setting both switch 3 and switch 8 to OFF (closed) sets all serial communication ports to 9600 bps

SW2 Setting	Function	Mode
		operation. All serial communication ports must be set at 9600 bps before WINDIAG can perform communication tests.
4	Core Updump	Causes the ControlWave Corrector to perform a core updump, provided you have set the SW1 switches to allow recovery mode. Values are: ON (Disables core updump; factory default) OFF Core updump
5	SRAM Control	Manages SRAM contents following a low power situation or a power outage. Values are: ON (Retain values in SRAM during restarts; factory default) OFF (Reinitialize SRAM) – Data in SRAM lost during power outage or re-start.
6	System Firmware	Allows a remote download of system firmware (on units equipped with boot PROM version 4.7 or higher and system PROM version 4.7 and higher). Values are: ON (Enable remote download of system firmware; factory default) OFF (Disable remote download of system firmware)
7	N/A	Not currently used.
8	Enable WINDIAG	Suspends normal operation and allows diagnostic routines. Values are: ON (Permits normal system operation, including the boot project, and disables the WINDIAG diagnostics from running; factory default) OFF (Allow WINDIAG to run test; disable boot project and normal system operation.) Note: Setting both switch 8 and switch 3 to OFF (closed) sets all communication ports to 9600 bps operation. All serial communication ports must be set at 9600 bps before WINDIAG can perform communication tests.

Note: Table 2-4 describes switch settings for RS-485 port operation. You may want to review *Section 2.5.6* on RS-485 configuration before you set these switches.

Table 2-4. RS-485 Configuration Switch SW3

Switch Setting	Function	Mode
1	TX+ to RX+ Loopback / 2-wire	ON (2-wire operation or loopback enabled) OFF (4-wire operation and loopback disabled)
2	TX- to RX- Loopback / 2-wire	ON (2-wire operation or loopback enabled) OFF (4-wire operation and loopback disabled)

Switch Setting	Function	Mode
3	100 Ohm RX+ Termination	ON (End nodes only)
4	100 Ohm RX- Termination	ON (End nodes only)
5	N/A	Not currently used
6	N/A	Not currently used
7	RX+ Bias (End Nodes/Node)	ON (4-wire = Both End nodes; 2-wire= One end node only) OFF = No bias
8	RX- Bias (End Nodes/Node)	ON (4-wire = Both End nodes only; 2-wire= One end node only) OFF = No bias

2.5.2 Setting Jumpers on the CPU/System Controller Board

The CPU has several jumpers.

- **W1:** COM1 CTS usage:
 - 1-to-2 Installed = COM1 CTS source is from device.
 - 2-to-3 Installed = COM1 RTS to CTS loopback
- **W2:** COM2 CTS usage:
 - 1-to-2 Installed = COM2 CTS source is from device.
 - 2-to-3 Installed = COM2 RTS to CTS loopback

Note: You must enable the backup battery by setting jumper W3 to position 1-2.

- **W3:** Enable/disable battery backup selection:
 - 1-to-2 Installed = Enable battery backup.
 - 2-to-3 Installed = Disable battery backup
- **W5:** Power supply shut down selection:
 - 1-to-2 Installed = 12/24V power supply shut down hysteresis
 - 2-to-3 Installed = 6V power supply shut down hysteresis
- **W6:** Power supply shut down selection:
 - 1-to-2 Installed = 12V power supply shut down
 - 2-to-3 Installed = 6/24V power supply shut down
- **W7:** Power fail trip point hysteresis selection:
 - 1-to-2 Installed = 12/24V power fail trip point hysteresis
 - 2-to-3 Installed = 6V power fail trip point hysteresis
- **W8:** Power fail trip point selection:
 - 1-to-2 Installed = 12V power fail trip point
 - 2-to-3 Installed = 6/24V power fail trip point
- **W12:** COM3 configuration selection:
 - 1-to-2 Installed = COM3 is RS-232

- 2-to-3 Installed = COM3 is RS-485
- **W13:** COM3 configuration selection:
 - 1-to-2 Installed = COM3 is RS-232
 - 2-to-3 Installed = COM3 is RS-485
- **W14:** COM3 configuration selection:
 - 1-to-2 Installed = COM3 is RS-232
 - 2-to-3 Installed = COM3 is RS-485
- **W15:** COM3 configuration selection:
 - 1-to-2 Installed = COM3 is RS-232
 - 2-to-3 Installed = COM3 is RS-485
- **W16:** COM3 configuration selection:
 - 1-to-2 Installed = COM3 is RS-232
 - 2-to-3 Installed = COM3 is RS-485
- **W17:** Input power selection (controls solar power shunt regulation. Not applicable for +24Vdc CPUs:)
 - 1-to-2 Installed = 6V power
 - 2-to-3 Installed = 12V power
- **W18:** COM1 connector selection:
 - 1-to-2 Installed = connector J4 (D connector) is active
 - 2-to-3 Installed = alternate connector J11 is active

2.5.3 General Wiring Guidelines

- ControlWave Corrector terminal blocks use compression-type terminals that accommodate up to #16 AWG wire.
- When making a connection, insert the bare end of the wire (approx ¼" max) into the clamp adjacent to the screw and secure the screw.
- To prevent shorts, ensure that no bare wire is exposed. If using standard wire, tin the bare end with solder to prevent flattening and improve conductivity.
- Allow some slack in the wire while making terminal connections. Slack makes the wires more manageable and helps minimize mechanical strain on the terminal blocks.

Note: Fuse F4 applies only for Class I Division 1 hazardous locations with the intrinsically safe ControlWave GFC-IS. See *Figure 2-11* to locate the fuse. See *Supplement CW-GFC-IS* for more information on the intrinsically safe ControlWave GFC-IS.

2.5.4 Wiring Power to the CPU/System Controller Board

 **Caution** At this time you can connect power wiring. However; for safety reasons and to prevent accidental damage to your bulk DC power supply, do not connect the pluggable terminal block connectors TB1 and TB2 to the CPU/System Controller board until after you install, wire, ground, and configure the entire unit.

Follow the instructions in *Section 2.5.3 General Wiring Guidelines* when wiring connections.

Power Supply Current Requirements Depending upon the CPU type, the ControlWave Corrector accepts either a 6Vdc, 12Vdc or 24Vdc bulk power input. You can estimate the maximum current required for your ControlWave Corrector using the following equation:

$$\text{Bulk +6/12/24 Vdc Supply Current} = \text{CPU/System Controller Board (with options)} + \text{Process I/O Board} + \text{LCD display/keypad} + \text{optional modem / radio}$$

Refer to *Table 2-5* for ControlWave Corrector power requirements based on the CPU type.

Table 2-5. ControlWave Corrector Bulk Power Requirements

CPU Type and Components	Bulk 6Vdc Power Supply	Bulk 12Vdc Power Supply	Bulk 24Vdc Power Supply
14 MHz Ultra Low Power CPU with LCD display/keypad	7 mA	without field supply and with AO output under range: 5 mA	Not Supported
33 MHz CPU with Ethernet and LCD display/keypad	Not Supported	without process I/O board: 80 mA	without process I/O board: 47 mA

Note: If your ControlWave Corrector includes a modem or radio, contact the radio/modem manufacturer for power consumption specifications.

 **Caution**

If your ControlWave Corrector is configured to use a solar panel to charge a 7AH (6V or 12V) battery for power, NEVER CONNECT THE SOLAR PANEL/CHARGER WITHOUT ALSO CONNECTING THE BATTERY. Connections without the battery present can damage power supply components.

Terminal Block Connector TB1 Unplug removable connector TB1 from the CPU/System Controller board. We recommend you do **not** plug the connector back into the CPU until the unit is already installed in the housing.

You can power the ControlWave Corrector using a bulk DC power supply using connections TB1-3 and TB1-4.

Nominal input source operating ranges for the DC power supply are:

- +6Vdc (+5.4Vdc to +16.0Vdc nominal operating range)
- +12Vdc (+11.4Vdc to +16.0Vdc nominal operating range)
- +24Vdc (+21.8Vdc to +28.0Vdc nominal operating range)

Not all ControlWave Corrector CPUs support all DC power supplies. Supported options are:

- 14MHz Ultra Low Power CPU: Supports +6Vdc or +12Vdc nominal power supply.
- 33MHz CPU with Ethernet: Supports +12Vdc nominal or +24Vdc nominal power supply.

Alternatively, you can power low powered versions of the ControlWave Corrector using a solar panel connected to a user-supplied rechargeable 7AH (6V/12V) lead acid battery.

TB1 connections are:

- TB1-1: (Solar Power IN+): Power from a 1W – 6V, 5W – 6V or 5W – 12V solar panel (internally wired to recharge a factory-supplied battery). **Not available on units with Ethernet.**
- TB1-2 = Ground (GND) **Not available on units with Ethernet.**
- TB1-3 = Primary Power: Power from an internal factory-supplied battery or from an external nominal +6Vdc , +12Vdc or +24Vdc power supply, depending upon the CPU type.
- TB1-4 = Ground (GND)
- TB1-5 = Auxiliary Power Out+: for a radio or modem (if supported). Aux power out enabled when DTR signal for COM2 goes high. **Aux Power Out not available on units with Ethernet.**
- TB1-6 = Ground (GND) for Aux power out.

Figure 2-12 shows the typical wiring at the TB1 block.

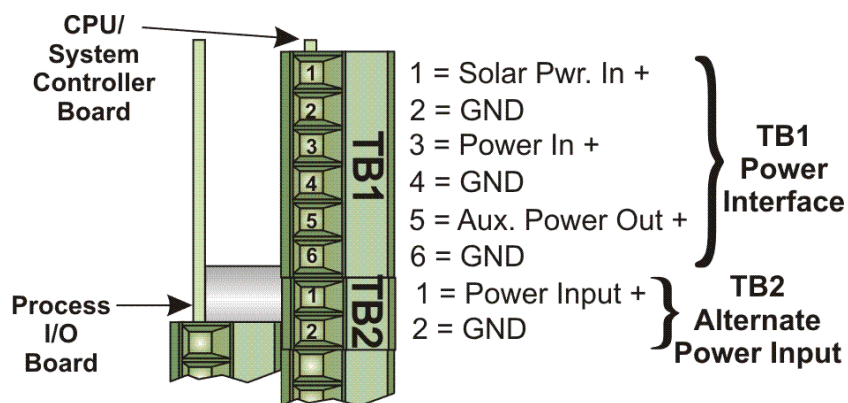

Figure 2-12. CPU/System Controller Board (TB1 & TB2) Power Wiring

Terminal Block Connector TB2 The ControlWave Corrector includes an alternative power connector, TB2, to provide power if none is available at TB1. For example, you can connect a bulk DC power supply to TB2 to handle situations where the solar panel/battery system does not have sufficient power.

TB2 connections are:

- TB2-1 = Power Input
- TB2-2 = Ground (GND)

2.5.5 Connections to RS-232 Serial Port(s) on the CPU/System Controller Board

An RS-232 port provides point-to-point, half-duplex and full-duplex communications (for a maximum of 20 feet using data quality cable).

Your CPU includes two RS-232 ports and one port configurable for either RS-232 or RS-485 operation.

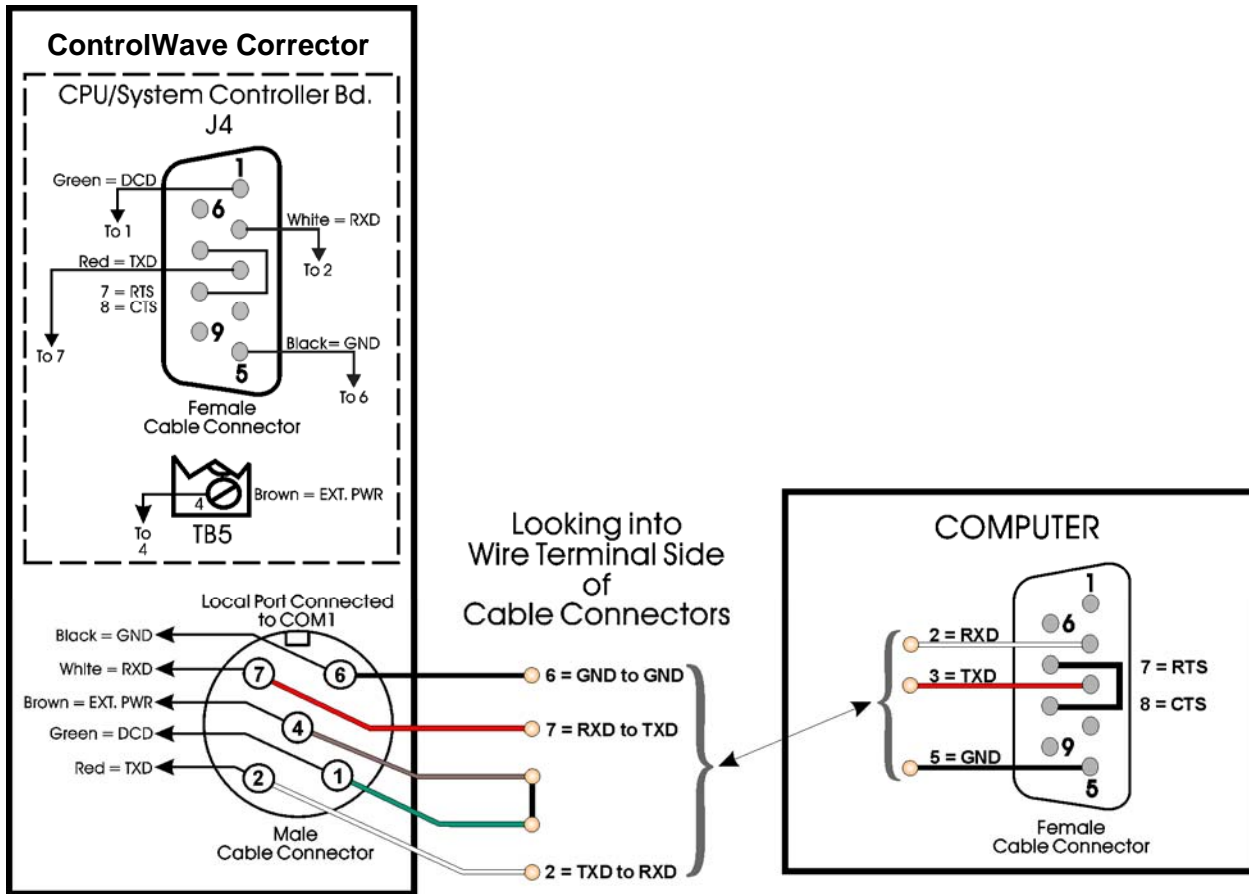

Figure 2- 13. PC Connected to ControlWave Corrector via Circular Local Port

Notes:

- Cable part number 395402-01-8 = 10 foot communication cable.
- Cable part number 395402-02-6 = 25 foot communication cable.

RS-232 COM Port Names and Connectors

RS-232 COM ports use different connector types.

Table 2-6. RS-232 Connectors

Connector	Name	# Pins and Type	Notes
J4	COM1	9-pin male D-type	Choice of active connector for COM1 determined by jumper W18. Ships from the factory connected to the local port on the bottom of the front cover of the unit.
J11	COM1	3-pin male	Choice of active connector for COM1 determined by jumper W18.
TB3	COM2	8-pin terminal block	Use this port for connection to a radio mounted on the battery cover/radio mounting plate.

Connector	Name	# Pins and Type	Notes
TB4	COM3	5-pin terminal block	This port can be configured as either RS-232 or RS-485. See <i>Section 2.5.6</i> for more information.

RS-232 COM1/COM2 Port Cables For the ControlWave Corrector, half-duplex communications use Modbus or BSAP protocol, while full-duplex communications use point-to-point protocol (PPP). RS-232 ports use a “null modem” cable (see *Figure 2-15*) to connect with other devices (such as a PC, a printer, another ControlWave [except the CW_10/30/35]) when the ControlWave Corrector uses the full-duplex PPP protocol.

Note: You can configure the ControlWave Corrector as either a master or slave node on a Modbus or BSAP network.

Figure 2-14 illustrates the CPU module’s male 9-pin D-type connector for COM1. Use the content provided in *Table 2-6* to determine pin assignments for the COM1 and COM2 ports.

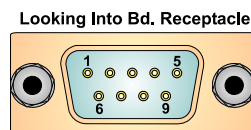

Figure 2-14. Male DB9 9-Pin Connector

Table 2-7. RS-232 COM1 and COM2 Port Connector Pin Assignment

Pin	RS-232 Signal	RS-232 Description	Local Port Pin#	Local Port Notes:
1	DCD	Data Carrier Detect Input	1 (Green wire)	
2	RXD	Receive Data Input	2 (Red wire)	
3	TXD	Transmit Data Output	7 (White wire)	
4	DTR	Data Terminal Ready Output	4 (Brown wire)	Pin 4 connected to pin 4 at TB5 of CPU = external power for local communication port cable.
5	GND	Power Ground	6 (Black wire)	
6	DSR	Data Set Ready Input		
7	RTS	Request to Send Output		RTS connected to CTS at J4 of CPU for local port communication cable.
8	CTS	Clear to Send Input		RTS connected to CTS at J4 of CPU for local port communication cable.
9		N/A		

Use the “null modem” cable for full-duplex (PPP protocol) communications when connecting a ControlWave Corrector to a PC. (See top part of *Figure 2-15*.)

Table 2-8. RS-232 COM1 (J11) Alternate Connector Pin Assignment

Pin	RS-232 Signal	RS-232 Description
1	GND	Power ground
2	RXD	Receive data input
3	TXD	Transmit data output

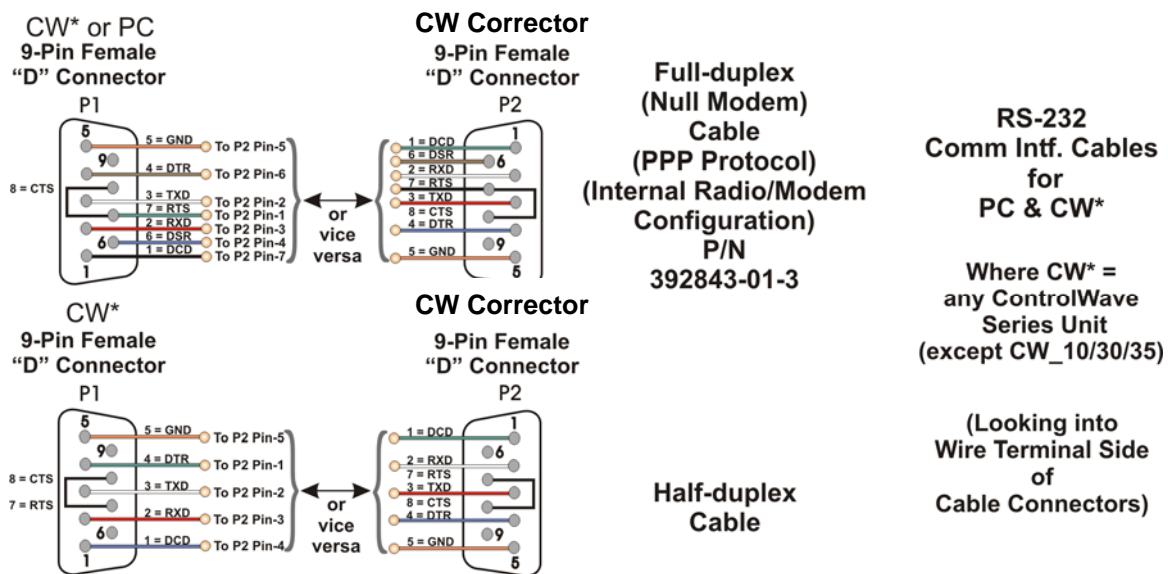

Figure 2-15. Full-duplex and Half-duplex Cable

Use the half-duplex cable (shown in the bottom part of *Figure 2-15*) when connecting the ControlWave Corrector to another ControlWave series unit (again, with the exception of the CW_10/30/35).

When communicating with a Network 3000 series RTU 3305, RTU 3310, DPC 3330, or DPC 3335 or CW_10/30/35, you must use one of the cables shown in *Figure 2-16*.

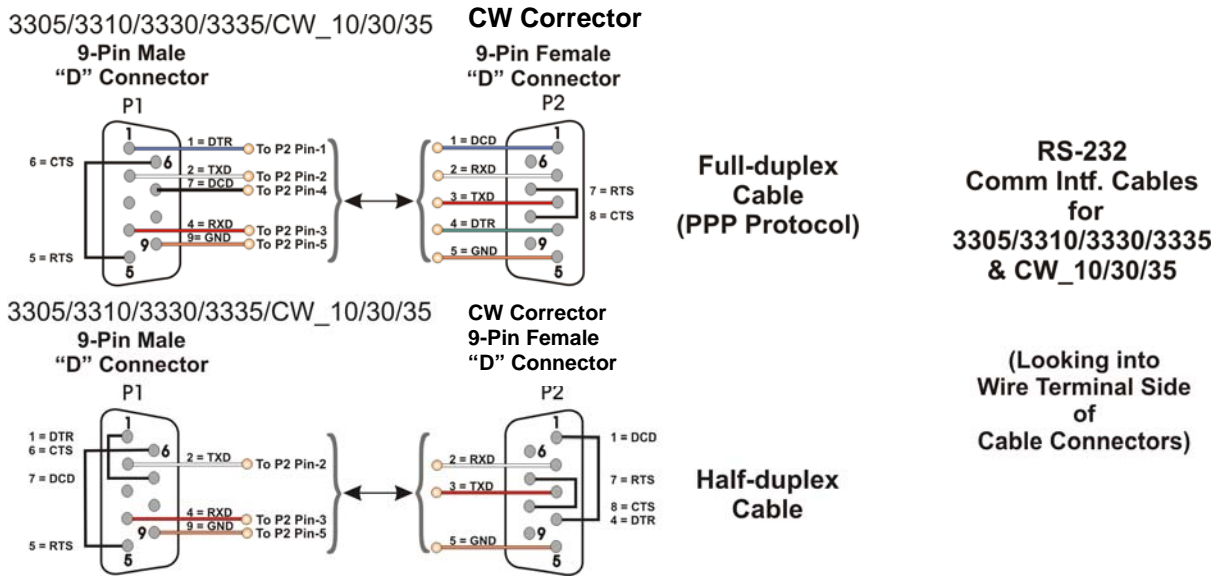

Figure 2-16. Full-duplex and Half-duplex Cable

Refer to Figure 2-17 when using COM2 of the ControlWave Corrector to connect with a case mounted modem or radio.

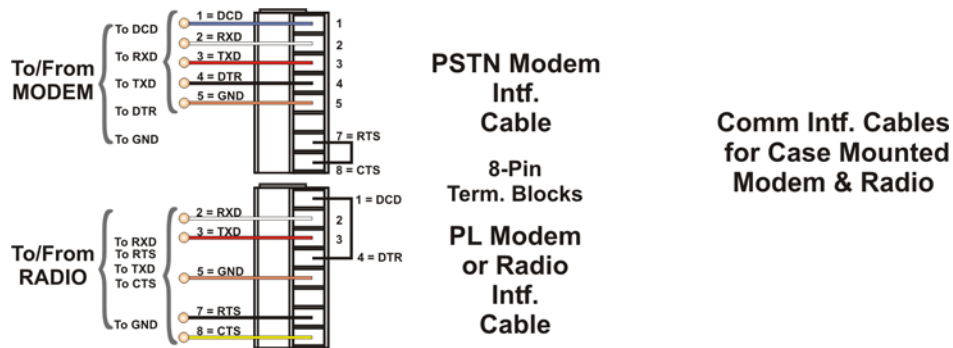

Figure 2-17. Connection from a Case Mounted Modem/Radio to COM2 of the ControlWave Corrector

When interfacing to the COM3 port of a ControlWave, or the COM5 or COM6 port a ControlWaveEXP unit, use the cable presented in Figure 2-18 along with one of the cables shown in Figure 2-15 or Figure 2-16.

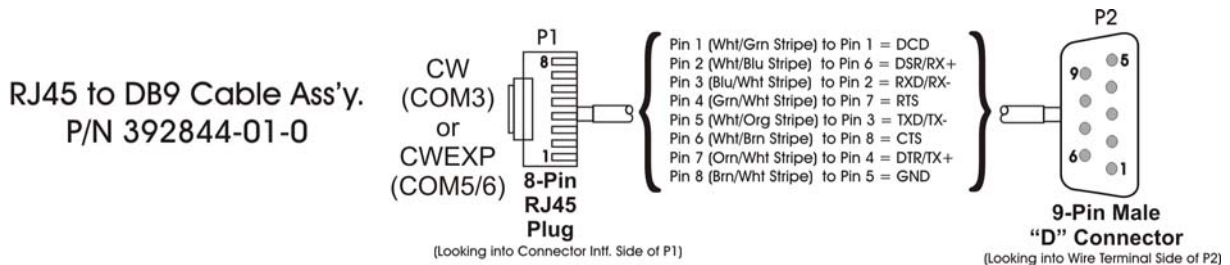

Figure 2-18. Full-duplex and Half-duplex Cable

RS-232 Cable Guidelines

Observe the following guidelines when constructing RS-232 communication cables:

- Ensure that DCD is high to transmit (except when dialing a modem)
- Verify that each RS-232 transceiver has one active receiver while disabled (in power down mode); connect the DCD signal to the active receiver.
- Set CTS to high to transmit.
- If the port is set for full-duplex operation, RTS is always ON.
- Ensure that DTR is always high when port is active; DTR enables RS-232 transceivers.

Note: Control DTR using the PORTCONTROL function block and the `_Pn_AUTO_DTR` system variable in your ControlWave project. If you turn DTR off through these mechanisms, the port remains off, even though hardware is fully configured.

- When port is set for half-duplex operation, CTS must go low after RTS goes low.
- All RS-232 comm ports support RTS, DTR, CTS, DCD, and DSR control signals.
- All RS-232 comm port I/O signals are protected by surge protectors.

2.5.6 Connections to the COM3 (RS-485/RS-232) Serial Port on the CPU/System Controller Board

You use jumpers W12 through W16 to configure COM3 of the ControlWave Corrector for either RS-232 or RS-485 operation. See *Section 2.5.2* for information on these jumpers.

Table 2-9. COM3 RS-485 Connector (TB4) on CPU/System Controller Board

Connector	Name	# Pins and Type	Notes
TB4	COM3	5-pin terminal block	This port can be configured as either RS-232 or RS-485.

RS-485 COM3 Port Cables

Table 2-10 shows connector pin assignments for COM3.

Note: If you use COM3 for RS-232 operation, pins 1 and 4 do not apply.

Table 2-10. COM3 Connector Pin Assignment

Pin	Signal	Description
1	RXD+	Receive Data + input (Not applicable for RS-232 usage)
2	RXD-/RXD	Receive Data – Input

Pin	Signal	Description
		RXD- for RS-485 use RXD for RS-232 use
3	TXD-/TXD	Transmit Data – Output TXD- for RS-485 use TXD for RS-232 use
4	TXD+	Transmit Data + Output (Not applicable for RS-232 usage)
5	Power Ground	Ground

When serving as an RS-485 port, COM3 supports local network communications to multiple nodes up to 4000 feet away.

Since the RS-485 port is intended for network communications, refer to *Table 2-11* for the appropriate connections for wiring the master, first slave, and *nth* slave.

Essentially, the master and the first slave transmit and receive data on opposite lines; all slaves (from the first to the *nth*) are paralleled (daisy-chained) across the same lines. Wire the master node to one end of the RS-485 cable run using a 24-gauge paired conductor cable (such as a Belden 9843).

Note: ControlWave Corrector supports **only** half-duplex RS-485 networks.

Table 2-11. RS-485 Network Connections

From Master	To First Slave	To nth Slave
TXD+	RXD+	RXD+
TXD-	RXD-	RXD-
RXD+	TXD+	TXD+
RXD-	TXD-	TXD-
GND/ISO GND	GND/ISO GND	GND/ISO GND

Note: ISO GND only applies to RS-485 usage.

To ensure that the “Receive Data” lines are in a proper state during inactive transmission periods, you must maintain certain bias voltage levels at the master and most distant slave units (end nodes). These end nodes also require the insertion of 100Ω terminating resistors to properly balance the network.

You must also configure switches at each node to establish proper network performance. Accomplish this by configuring switches listed so that the 100Ω termination resistors and biasing networks are installed at the end nodes and are removed at all other nodes on the network. You enable receiver biasing and termination (as well as 2-wire or 4-wire selection) using an 8-position DIP switch located on the CPU/System Controller board. See *Table 2-4* for more information.

2.5.7 Connections to the Ethernet Port on the CPU/System Controller Board

Caution

The RJ45 Ethernet port is connector (J1) located on the CPU/System Controller board. The board also has one RJ45 port (J2) for the optional Display/Keypad. **Never** connect Ethernet to J2 (the Display/Keypad port) or damage will result.

The 33MHz ControlWave Corrector can support one Ethernet port. This port uses a 10/100Base-T RJ-45 modular connector (J1) that provides a shielded twisted pair interface to an Ethernet hub.

A typical Ethernet hub provides eight 10/100Base-T RJ-45 ports (with port 8 having the capability to link either to another hub or to an Ethernet communications port). Both ends of the Ethernet twisted pair cable are equipped with modular RJ-45 connectors.

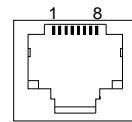

Looking into receptacle

Figure 2-19. RJ-45 Ethernet Connector

These cables have a one-to-one wiring configuration as shown in Figure 2-20. Table 2-12 provides the assignment and definitions of the 8-pin 10/100Base-T connectors.

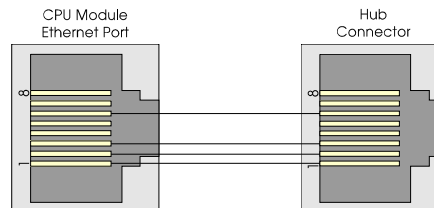

Figure 2-20. Standard 10/100Base-T Ethernet Cable (CPU Module to Hub)

Table 2-12. Ethernet 10/100Base-T CPU Module Pin Assignments

Pin	Description
1	Transmit Data+ (Output)
2	Transmit Data- (Output)
3	Receive Data+ (Input)
4	Not connected
5	Not connected
6	Receive Data- (Input)

Pin	Description
7	Not connected
8	Not connected

Note: You can swap TX and RX at the hub.

You can connect two nodes in a point-to-point configuration without using a hub. However, you must configure the cable so that the TX+/- Data pins connect to the RX+/- Data pins (swapped) at the opposite ends of the cable (see *Figure 2-21*).

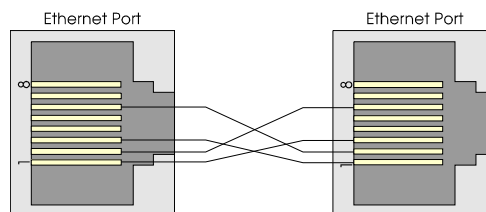

Figure 2-21. Point-to-Point 10/100Base T Ethernet Cable

The maximum length of one segment (CPU to hub) is 100 meters (328 feet). The use of Category 5 shielded cable is recommended.

2.6 Radio-Ready and Case Mounted Modem or Radio

The ControlWave Corrector ships from the factory with a user selected radio or modem installed within the enclosure (in front of the battery mounting bracket) or as a radio-ready unit, in other words, ready for field installation of a factory-supplied radio. The installer must ensure that the remote antenna (associated with a case mounted radio) is properly installed and connected.

See the *ControlWave Radio-Ready Installation Guide* (D5138) for information on installing factory-supplied radios in the field.

See the *ControlWave PSTN Modem Installation Guide* (D301734X012) for information on installing the 9600 bps PSTN modem.

2.7 Mounting the Solar Panel

Depending upon the type of power system you choose, your ControlWave Corrector may require a solar panel. The solar panel charges a rechargeable 6V or 12V 7AH lead acid battery. Solar panel wires enter the unit through a liquid tight conduit fitting and connect to TB1 on the CPU/System Controller board.

Caution

If your ControlWave Corrector is configured to use a solar panel to charge a 7AH (6V or 12V) battery for power, NEVER CONNECT THE SOLAR PANEL/CHARGER WITHOUT ALSO CONNECTING THE BATTERY. Connections without the battery present can damage power supply components.

You can mount the solar panel to a 2" to 2-3/8" pipe using muffler (pipe) clamps. You secure the pipe clamps using four 1/4-20 nuts and washers. (See *Figure 2-22* and *Figure 2-23*.)

You must swivel the solar panel for optimum alignment with the sun. In the northern hemisphere, face the panel due south (not magnetic south). In the southern hemisphere, face the panel due north (not magnetic north).

1 and 5 watt solar panel systems have adjustable tilt angles. Adjust the tilt angle for maximum performance to accommodate the latitude of your installation site. *Table 2-13* shows the angle (from horizontal) at which you should install the solar panel to maximize annual energy output. At most latitudes, performance can be improved by less of an angle during the summer and more of an angle during winter.

Table 2-13. Solar Panel Tilt Angle

Latitude	Tilt Angle
0-4°	10° from Horizontal
5-20°	Add 5° to the Local Latitude
21-45°	Add 10° to the Local Latitude
46-65°	Add 15° to the Local Latitude
66-75°	80° from Horizontal

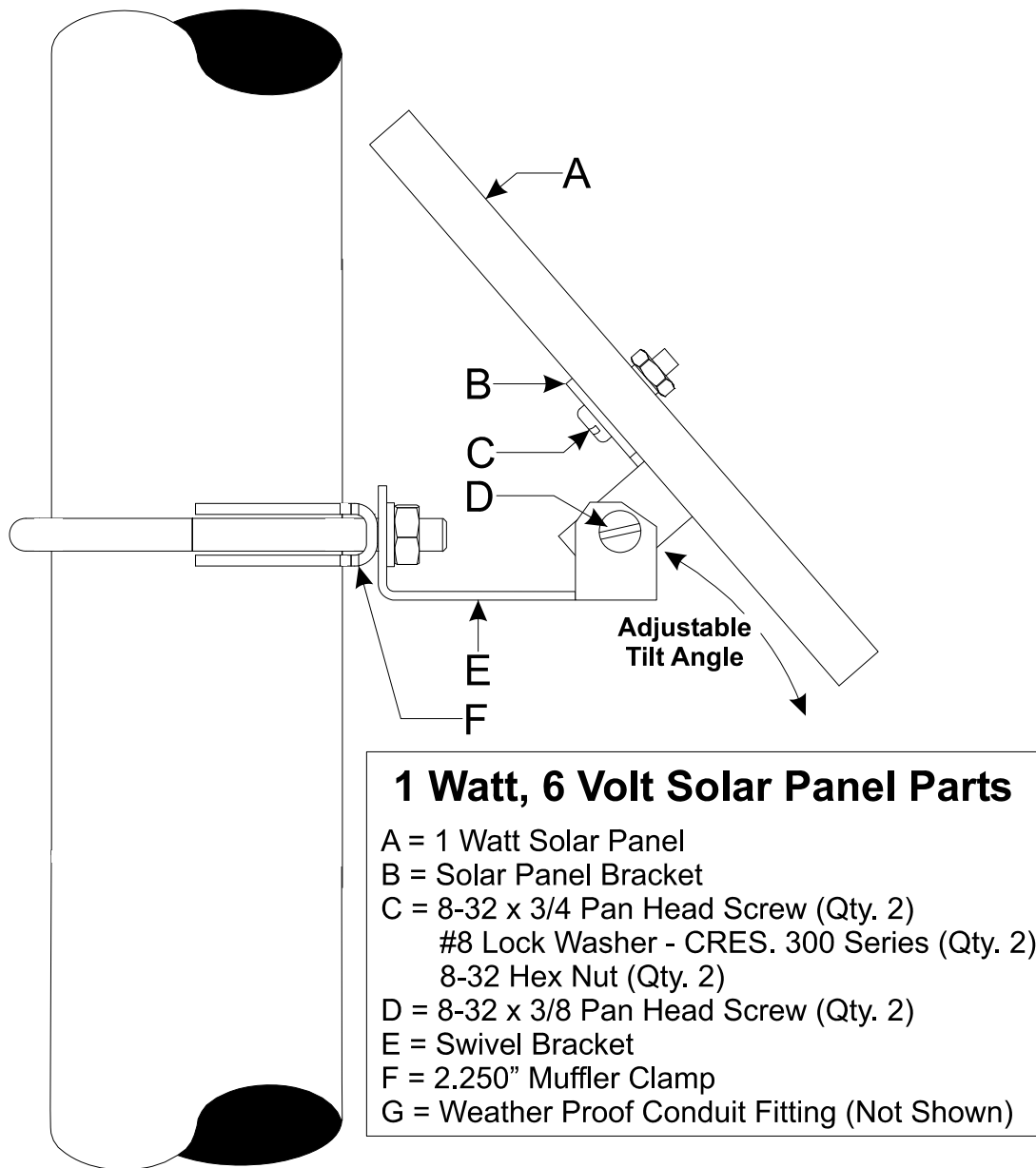
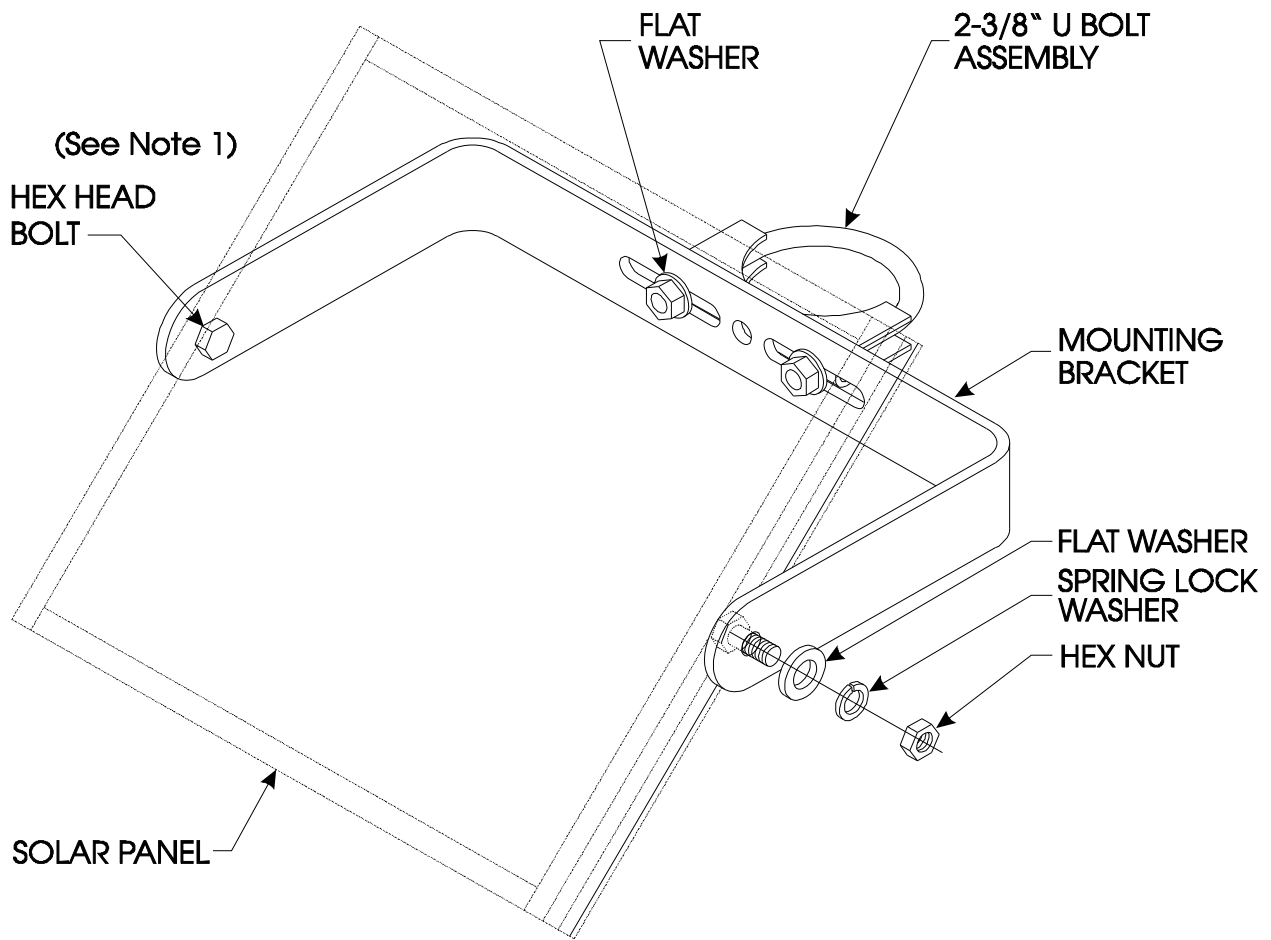

Figure 2-22. 1 Watt Solar Panel Mounting Diagram



NOTE 1:
 SLIDE THE BOLT HEADS INTO THE
 CHANNELS IN THE SIDES OF THE
 SOLAR PANEL. MAX. TORQUE 125
 INCH-POUNDS.

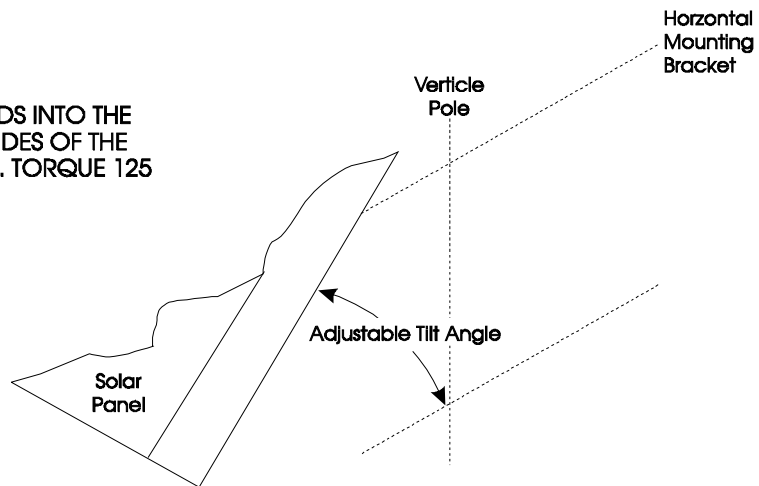

Figure 2-23. 5 Watt Solar Panel Mounting Diagram

2.8 Optional Display/Keypads

The ControlWave Corrector supports two optional display/keypads and a display without a keypad:

- A 2-button keypad (shown in the left of *Figure 2-24*)
- A 25-button keypad (shown in the right *Figure 2-24*)
- Display only (no keypad) – (see *Figure 2-25*)

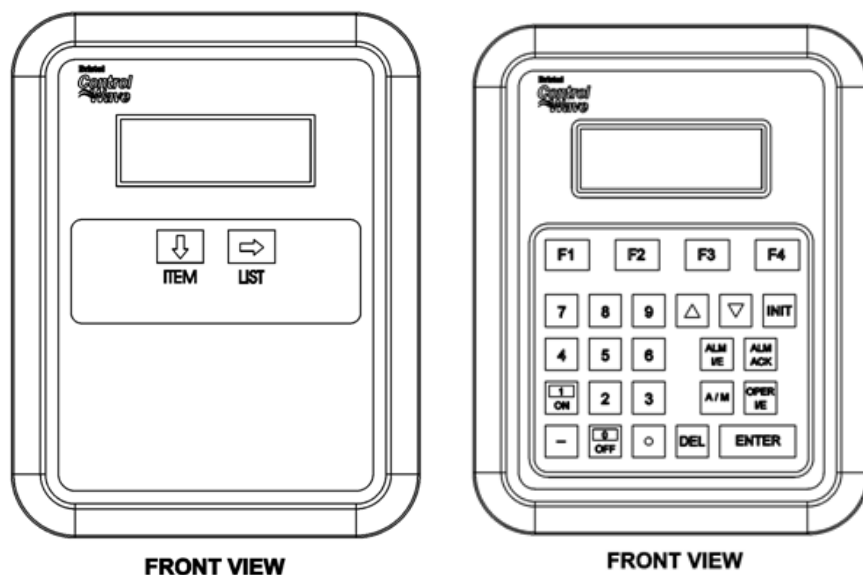

Figure 2-24. Optional 2-Button and 25-Button Keypads

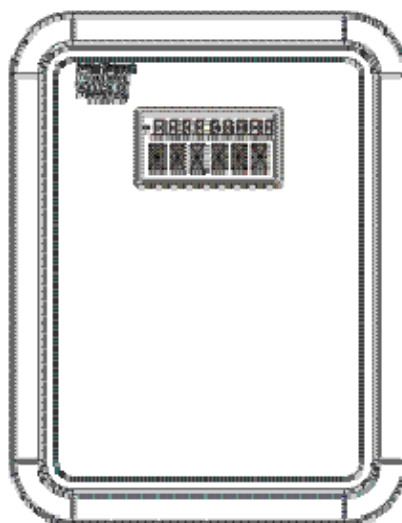

Figure 2-25. Display with No Keypad

Both keypads use the same 4-line by 20-character LCD displays.

The Display without a keypad has a 2-line display with 10 characters on the first line, and 6 characters on the second line. This display shows variable values on line 1, and variable names on line 2.

You connect the Display/Keypad or Display to the ControlWave Corrector using a cable, one end of which has an RJ-45 jack (connected into the RJ-45 equipped with two plugs. This cable connects between the RJ-45 display jack (J2) on the CPU/System Controller board and RJ-45 jack (J1) on the remote Display or remote Display/Keypad assembly. A potentiometer, provided on the keypad, allows you to set the contrast of the LCD display.

Notes:

- For information on the status codes which appear on the display, see *Section 5.3.3 Checking LCD Status Codes in Chapter 5*.
 - For further information on the installation and use of the optional keypads, refer to the *ControlWave Display/Keypad Manual (D5135)*.
-

Chapter 3 – I/O Configuration and Wiring

This chapter discusses setting I/O configuration switches and jumpers and wiring I/O connections to the ControlWave Corrector.

In This Chapter

3.1	I/O Options.....	3-1
3.2	Process I/O Board	3-2
3.2.1	Setting Jumpers on the Process I/O Board.....	3-2
3.2.2	Setting DIP Switches on the Process I/O Board	3-2
3.3	I/O Wiring.....	3-4
3.3.1	Non-Isolated Discrete Inputs (DI) on TB2 and TB3 of Process I/O Board	3-6
3.3.2	Non-Isolated Discrete Outputs (DO) on TB3 of Process I/O Board	3-7
3.3.3	Non-Isolated Analog Inputs (AI) on TB6 of Process I/O Board	3-8
3.3.4	Non-Isolated Analog Output (AO) on TB7 of Process I/O Board	3-9
3.3.5	Non-Isolated Pulse Counter/Discrete Inputs on TB5 of CPU/System Controller Board.....	3-10
3.3.6	Non-Isolated High Speed Counter (HSC) / Discrete Inputs (DI) on TB4 of Process I/O Board.....	3-13
3.3.7	Resistance Temperature Device (RTD) Inputs on CPU/System Controller Board.....	3-14
3.3.8	Connections to a Bristol Model 3808 Transmitter	3-16

3.1 I/O Options

ControlWave Corrector comes with the following standard I/O:

- 2 Pulse Counter Inputs with a 1 second scan rate (can be configured as discrete inputs (DI))

I/O Options include:

- Gage Pressure Transducer (GPT)
- The 14 MHz CPU and the 33MHz CPU with Ethernet also includes a Resistance Temperature Device (RTD) probe.

In addition, three different versions of the optional process I/O board are available. See *Table 3-1*.

Table 3-1. Process I/O Configurations

Type	Pulse Counter Inputs (PI) / Discrete Inputs (DI)	Discrete Input / Output (DI/DO)	Discrete Input (DI)	Discrete Output (DO)	High Speed Counter (HSC)	Analog Input (AI)	Analog Output (AO)
Standard	2						
Option 1	2	2	4	2	2		
Option 2	2	2	4	2	2	3	
Option 3	2	2	4	2	2	3	1

3.2 Process I/O Board

The ControlWave Corrector may include an optional Process I/O board.

The Process I/O board stands vertically on edge against the inner left side of the enclosure and mounts to the CPU/System Controller board using six nylon mounting posts.

To configure the Process I/O board, you need to set some switches and jumpers. See *Figure 3-1* for the location of the switches and jumpers.

3.2.1 Setting Jumpers on the Process I/O Board

The Process I/O board has several jumpers.

- **JP1:** AO output source (1-5V or 4-20mA):
 - 1-to-2 Installed = 4-20mA analog output
 - 2-to-3 Installed = 1-5V analog output
- **JP3:** AO power source:
 - 1-to-2 Installed = system power
 - 2-to-3 Installed = external power (+11 to +30 Vdc)
- **JP4:** AI field power configuration:
 - 1-to-2 Installed = external power
 - 2-to-3 Installed = bulk input supply (system power)
- **JP5:** AI1 input type (1-5V or 4-20mA)
 - 1-to-2 Installed = 4-20mA analog input
 - 2-to-3 Installed = 1-5V analog input
- **JP6:** AI2 input type (1-5V or 4-20mA)
 - 1-to-2 Installed = 4-20mA analog input
 - 2-to-3 Installed = 1-5V analog input
- **JP7:** AI3 input type (1-5V or 4-20mA)
 - 1-to-2 Installed = 4-20mA analog input
 - 2-to-3 Installed = 1-5V analog input

3.2.2 Setting DIP Switches on the Process I/O Board

The Process I/O board includes a single switch bank (SW1) to configure the frequency for the high speed counters (HSC), the source current for discrete inputs/counters, and the analog output.

Table 3-2. Process I/O Module Switch SW1

SW1	Function	Mode
SW1-1	Frequency for High Speed Counter1 (HSC1)	OFF = 10 kHz (high speed) ON = 300 Hz (low speed)
SW1-2	Frequency for High Speed Counter2 (HSC2)	OFF = 10 kHz (high speed) ON = 300 Hz (low speed)

SW1	Function	Mode
SW1-3	DI/HSC 2mA source current	OFF = disabled ON = enabled Note: This switch affects all DIs and HSCs.
SW1-4	AO configuration	OFF = current ON = voltage

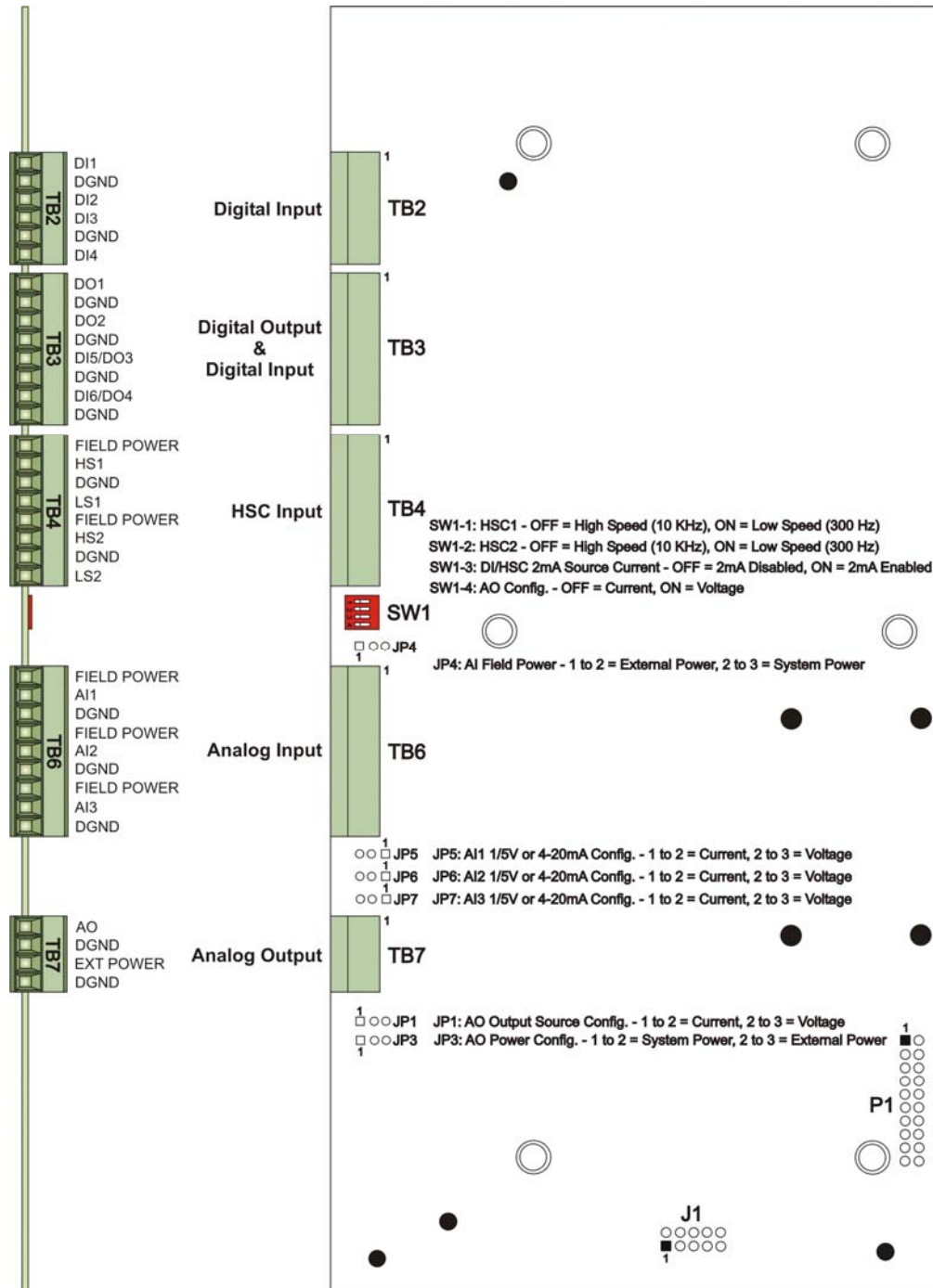

Figure 3-1. Process I/O Board Component Identification Diagram



Caution

Power down the ControlWave Corrector before you perform I/O wiring. Shut down any processes the ControlWave Corrector may be managing (or switch them over manually or handle with another controller). Perform any hardware configuration (wiring, jumper configuration, and installation) only when the ControlWave Corrector is powered down.

Before any I/O connections can become operational, you must use ControlWave Designer to configure and then download the application (project).

To ensure safe use of this product, please review and follow the instructions in the following supplemental documentation:

- Supplement Guide - ControlWave Site Considerations for Equipment Installation, Grounding, and Wiring (S1400CW)
 - ESDS Manual – Care and Handling of PC Boards and ESD Sensitive Components (S14006)
-

3.3 I/O Wiring

The ControlWave Corrector uses card edge terminal blocks to accommodate field wiring. You route the wires into the enclosure/chassis through a 0.75 inch conduit fitting.

ControlWave Corrector I/O uses compression-type terminals that accommodate up to #16 AWG wire. Insert the wire's bared end (approx. 1/4" max) into the clamp beneath the screw and secure the wire. To prevent shorts, ensure that no bare wire is exposed. If using standard wire, tin the bare end with solder to prevent flattening and improve conductivity. Allow some slack in the wires when making terminal connections. Slack makes the wires more manageable and helps minimize mechanical strain on the terminal blocks.

Shielding and Grounding

Use twisted-pair, shielded and insulated cable for I/O signal wiring to minimize signal errors caused by electromagnetic interference (EMI), radio frequency interference (RFI), and transients. When using shielded cable, ground all shields at only one point in the appropriate system. This prevents circulating ground current loops that can cause signal errors.

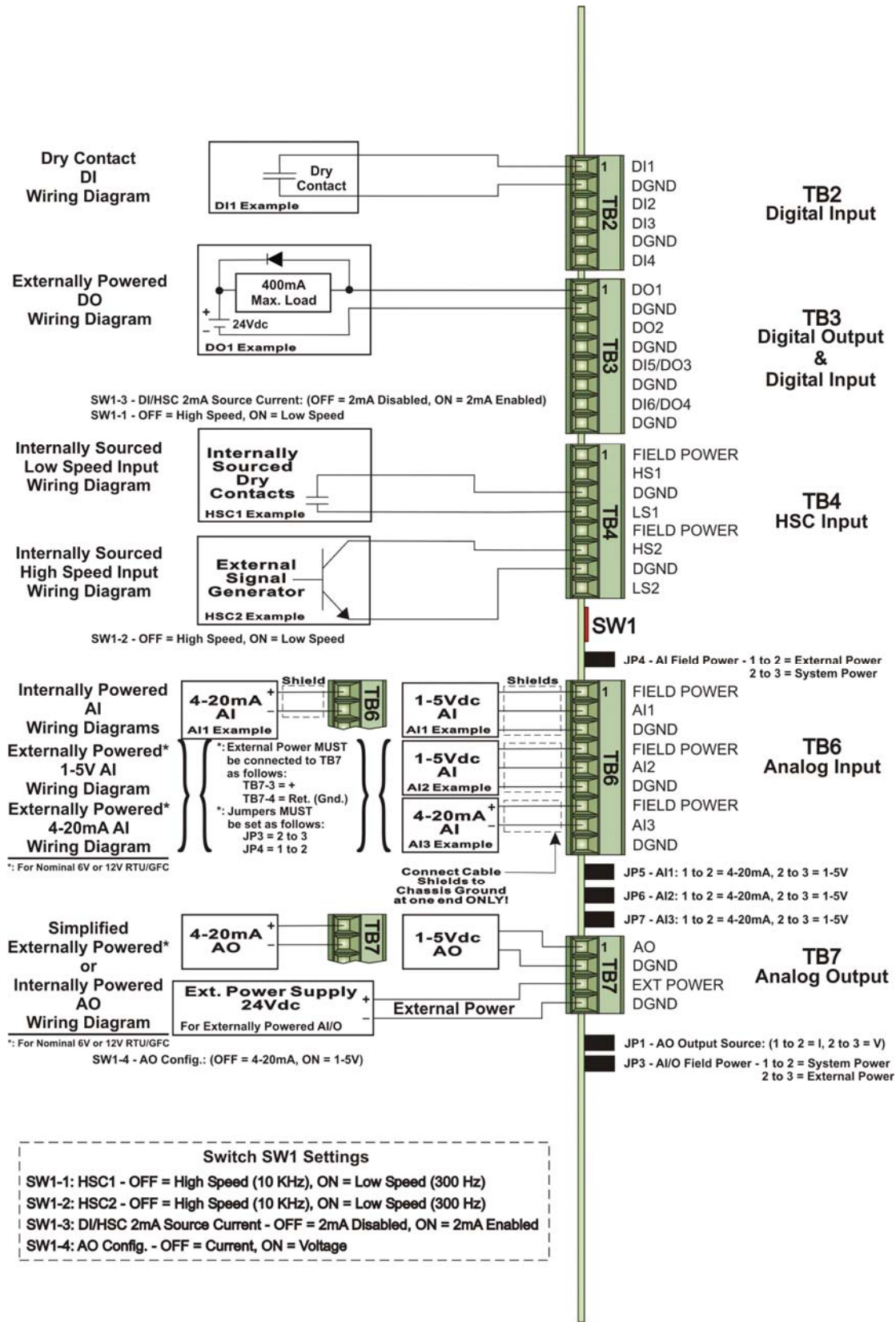

Figure 3-2. Process I/O Board Wiring Diagrams

3.3.1 Non-Isolated Discrete Inputs (DI) on TB2 and TB3 of Process I/O Board

Process I/O Board terminal block connector TB2 provides interface to four dedicated non-isolated discrete inputs DIs – DI1 through DI4. In addition, terminal block connector TB3 provides two additional points that can serve as either discrete inputs or discrete outputs (DI5 and DI6 when wired as inputs).

Table 3-3. Non-Isolated DI General Characteristics

Type	Number Supported	Characteristics
Discrete Inputs (DI)	4 on TB2 (optionally 2 on TB3)	<ul style="list-style-type: none"> ▪ Supports dry contact inputs pulled internally to 3.3 Vdc when field input is open. ▪ Source current for DI1 to DI4 of either 60 μA or 2 mA based on switch SW1-3 setting. See <i>Table 3-2</i>. ▪ Source current for DI5 to DI6 of either 200 μA or 2.2 mA based on switch SW1-3 setting. See <i>Table 3-2</i>. ▪ 15 ms input filtering

Wiring See *Figure 3-2* for wiring diagrams.

Software Configuration To use data from these DIs you must include a **CWM_EIO** board in your ControlWave project using ControlWave Designer's I/O Configurator, and then configure it. See the *ControlWave Designer Programmer's Handbook (D5125)* for more information. That same manual includes an *I/O Mapping* section that describes, for advanced users, the I/O map for this board.

Note: You must specify whether a discrete input/output is a DI or a DO in ControlWave Designer's I/O Configurator by configuring a DI pin or a DO pin.

3.3.2 Non-Isolated Discrete Outputs (DO) on TB3 of Process I/O Board

Process I/O Board terminal block connector TB3 provides interface to two dedicated non-isolated discrete outputs DOs – DO1 and DO2. In addition, terminal block connector TB3 provides two additional points that can serve as either discrete inputs or discrete outputs (DO3 and DO4 when wired as outputs).

Table 3-4. Non-Isolated DO General Characteristics

Type	Number Supported	Characteristics
Discrete Outputs (DO)	2 to 4 (on TB3)	<ul style="list-style-type: none"> ▪ Supports 30V operating range. Can sink 400 mA max at 30Vdc (open drain). ▪ Maximum output frequency of 20Hz. ▪ Surge protection between signal and ground.

Wiring See *Figure 3-2* for wiring diagrams.

Software Configuration To use data from these DOs you must include a **CWM_EIO** board in your ControlWave project using ControlWave Designer's I/O Configurator, and then configure it. See the *ControlWave Designer Programmer's Handbook (D5125)* for more information. That same manual includes an *I/O Mapping* section that describes, for advanced users, the I/O map for this board.

Note: You must specify whether a discrete input/output is a DO or a DI in ControlWave Designer's I/O Configurator by configuring a DO pin or a DI pin.

3.3.3 Non-Isolated Analog Inputs (AI) on TB6 of Process I/O Board

Process I/O Board terminal block connector TB6 provides interface to three single-ended analog inputs (AIs).

Table 3-5. Non-Isolated AI General Characteristics

Type	Number Supported	Characteristics
Analog Inputs (AI)	3 (on TB6)	<ul style="list-style-type: none"> ▪ Jumper-selectable using JP5, JP6, and JP7 for either 4-20mA or 1-5V operation. ▪ Jumper JP4 determines whether AI field power comes from system power (bulk input supply applied to TB1-3 and TB1-4 on the CPU/System Controller Board) or the external loop power source connected to TB7-3 and TB7-4 on the Process I/O board. ▪ 2 Hz low pass filter for each AI. ▪ Surge Suppression. ▪ Self calibrating.

Setting Jumpers See *Section 3.2.1* for details on setting jumpers.

Wiring Each AI includes three terminals (field power, AI# and DGND). See *Figure 3-2* for wiring diagrams. If using the ControlWave Loop Power Supply, see document *PIP-ControlWave-LS*.

Notes:

- You must connect cable shields associated with AI wiring to the ControlWave Corrector chassis ground.
 - Multiple shield terminations require you to supply a copper ground bus. You must connect the ground bus to the ControlWave Corrector chassis ground lug using up to a #4 AWG wire size. The ground bus must accommodate a connection to a known good Earth ground (in lieu of a direct connection from the ControlWave Corrector chassis ground) and to all AI cable shields.
 - Use an appropriate terminal lug for shield wires and secure them to the copper bus using industry rugged hardware (screw/bolt, lock washer and nuts).
-

Software Configuration To use data from these AIs you must include a **CWM_EIO** board in your ControlWave project using ControlWave Designer's I/O Configurator, and then configure it. See the *ControlWave Designer Programmer's Handbook* (D5125) for more information. That same manual includes an *I/O Mapping* section that describes, for advanced users, the I/O map for this board.

3.3.4 Non-Isolated Analog Output (AO) on TB7 of Process I/O Board

Process I/O Board terminal block connector TB7 provides interface to a single analog output (AO).

Table 3-6. Non-Isolated AO General Characteristics

Type	Number Supported	Characteristics
Analog Output (AO)	1 (on TB7)	<ul style="list-style-type: none"> ▪ Supports either 4-20mA or 1-5V operation. Selection using jumper JP1 and switch SW1-4. ▪ Jumper JP3 determines whether AO field power comes from system power (nominally 12 or 24V from bulk input supply applied to TB1-3 and TB1-4 on the CPU/System Controller Board) or from an external 24V power source (+11 to +30Vdc connected to TB7-3 and TB7-4) such as the ControlWave Loop Power Supply. ▪ Maximum external load you can connect to a 4-20mA output is 250 ohms for an external 11V power source or 650 ohms for an external 24V power source. ▪ Maximum external load current for the 1-5V output is 5 mA (with an external 11 to 30 V power source.) ▪ Factory-calibrated.

Setting Jumpers See *Section 3.2.1* for details on setting jumpers.

Wiring See *Figure 3-2* for wiring diagrams. If using the ControlWave Loop Power Supply, see document *PIP-ControlWave-LS*.

Note: **If your ControlWave Corrector uses 6V bulk power, you must provide external power for the AO.**

Software Configuration To use data from this AO you must include a **CWM_EIO** board in your ControlWave project using ControlWave Designer's I/O Configurator, and then configure it. See the *ControlWave Designer Programmer's Handbook (D5125)* for more information. That same manual includes an *I/O Mapping* section that describes, for advanced users, the I/O map for this board.

3.3.5 Non-Isolated Pulse Counter/Discrete Inputs on TB5 of CPU/System Controller Board

CPU/System Controller Board connector TB5 provides interface to two internally sourced open collector pulse counter/discrete inputs (Pulse1 and Pulse2) with a 1 second scan rate. Pulse counters act like high speed counters but cannot function with contact relays because they lack contact debounce circuitry.

Table 3-7. Non-Isolated Pulse Counter/Discrete Inputs General Characteristics

Type	Number Supported	Characteristics
Pulse Counter / Discrete Inputs	2 on TB5 of CPU/System Controller board	<ul style="list-style-type: none"> ▪ Signal conditioning circuitry provides 20 microsecond filtering. ▪ Surge suppression. ▪ Maximum input frequency for each pulse counter/discrete input circuit is 10 KHz.

Wiring Pulse counter/discrete inputs are field driven by open collector circuits and are sourced for 3.3V (internally) with a 200 μ A source current. See *Figure 3-3* for information on the open collector wiring arrangement.

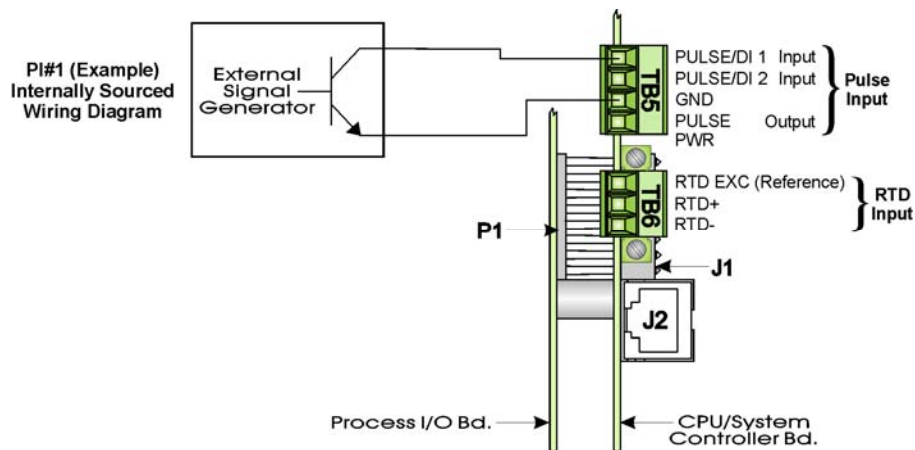

Figure 3-3. Pulse Input Wiring Diagram

If the pulse counter inputs come from a turbine meter through the optional TeleCounter (pulser) assembly (mounted to the base of the enclosure) the wiring diagram shown in *Figure 3-4* is utilized (factory-installed).

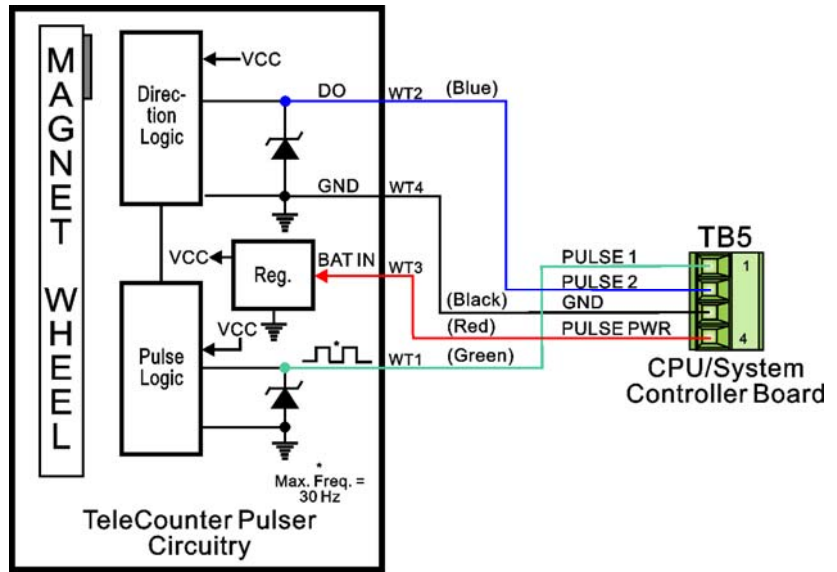

Figure 3-4. TeleCounter Wiring Diagram

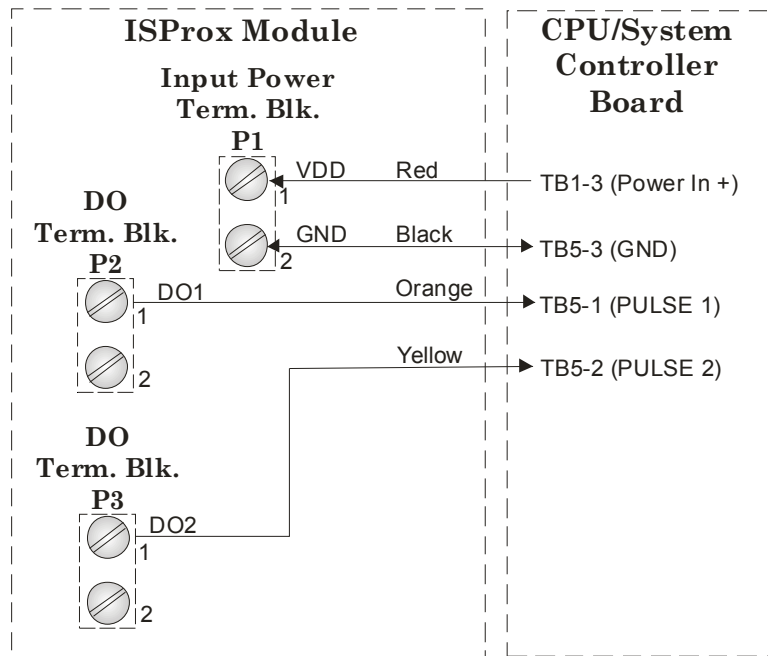

Figure 3-5. ISProx Wiring Diagram (see PIP-ISProx)

When a ControlWave Corrector is equipped with an optional ISProx assembly, (mounted on the inside of the unit's Front Cover), the wiring diagram shown in *Figure 3-5* is utilized (factory installed).

Software Configuration To use data from these pulse counter/discrete inputs you must include a **CWM_ECPU** board in your ControlWave project using ControlWave Designer's I/O Configurator, and then configure it. See the *ControlWave Designer Programmer's Handbook (D5125)* for more information. That same manual includes an *I/O Mapping* section that describes, for advanced users, the I/O map for this board. To read a DI value, look at the appropriate offset for the `_STATE` variable for the board.

3.3.6 Non-Isolated High Speed Counter (HSC) / Discrete Inputs (DI) on TB4 of Process I/O Board

Process I/O Board connector TB4 provides interface to two internally sourced single-ended high speed counter/discrete inputs (HSC1 and HSC2).

Table 3-8. Non-Isolated High Speed Counter/Discrete Inputs General Characteristics

Type	Number Supported	Characteristics
High Speed Counter / Discrete Inputs	2 on TB4 of Process I/O board	<ul style="list-style-type: none"> ▪ Surge suppression and signal conditioning. ▪ HSCs can use dry contacts or open collector field circuits. ▪ High speed counter switch-selectable frequency of 10kHz or 300Hz. ▪ Sourced from 3.3Vdc and switch selectable for a source current of 200μA (switch SW1-3 = OFF) or 2.2mA (switch SW1-3 = ON). Note: These switches affect all DIs and HSCs.

Wiring See *Figure 3-2* for wiring diagrams.

Switch Settings See *Table 3-2* for details on setting switches.

Software Configuration To use data from these high speed counter/discrete inputs you must include a **CWM_EIO** board in your ControlWave project using ControlWave Designer's I/O Configurator, and then configure it. See the *ControlWave Designer Programmer's Handbook (D5125)* for more information. That same manual includes an *I/O Mapping* section that describes, for advanced users, the I/O map for this board. To read a DI value, look at the appropriate offset for the `_STATE` variable for the board.

3.3.7 Resistance Temperature Device (RTD) Inputs on CPU/System Controller Board

CPU/System Controller Board connector TB6 provides connection to a 3-wire 100 ohm platinum bulb RTD (using the DIN 43760 curve).

Wire the RTD according to *Table 3-9* and *Figure 3-6* and *Figure 3-7*. In this configuration, the return lead connects to the RTD- terminal and the two junction leads (Sense and Excitation) connect to the RTD+ and RTD EXC terminals.



Caution

Never ground the RTD cable shield at both ends or allow it to come in contact with metallic/conductive conduit because multiple ground paths can cause RTD input errors.

Table 3-9. RTD Connections to CPU/System Controller Board Connector TB6

TB6 Pin	Signal	Function
1	RTD EXC	Reference
2	RTD+	Sense
3	RTD-	Return

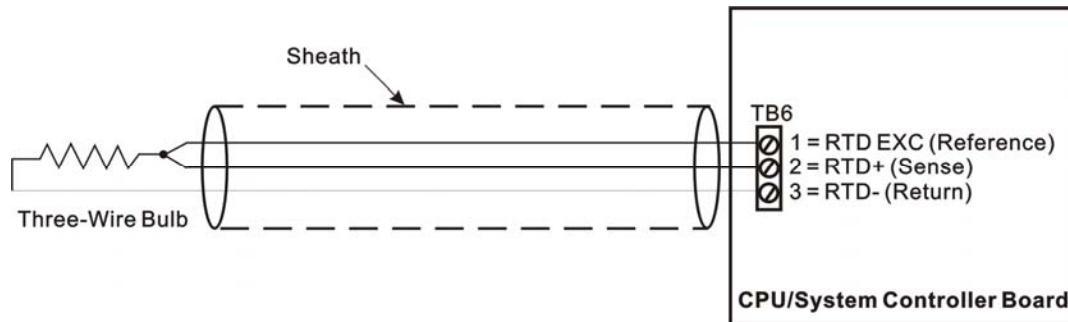

Figure 3-6. 3-Wire RTD Temperature Input Wiring

Installing the RTD Probe

To install the RTD probe, screw the fitting body into the thermowell with a 7/8" open-end wrench. While you apply pressure against the sheath to force the tip of the RTD probe into the bottom of the thermowell (so that the probe tip is in contact with the bottom of the thermowell), tighten the 9/16" nut using an open-end wrench against the 7/8" fitting body.

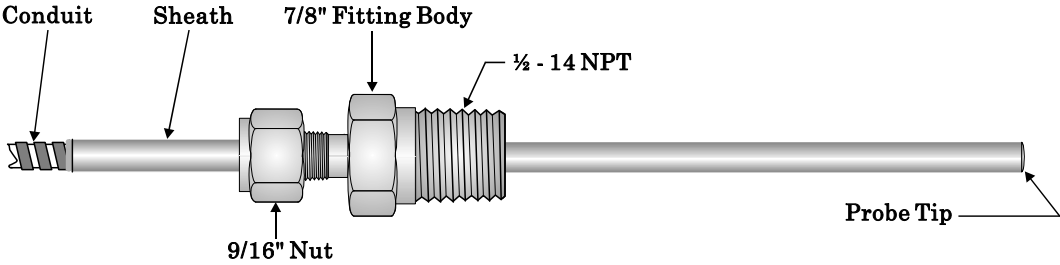

Figure 3-7. RTD Probe Installation/Removal Diagram

Software Configuration To use data from the RTD you must include a **CWM_ECPU** board in your ControlWave project using ControlWave Designer’s I/O Configurator, and then configure it. See the *ControlWave Designer Programmer's Handbook* (D5125) for more information. That same manual includes an *I/O Mapping* section that describes, for advanced users, the I/O map for this module.

3.3.8 Connections to a Bristol Model 3808 Transmitter

You can connect a Bristol 3808 transmitter (digital) to the ControlWave through either an RS-232 or RS-485 port. Communication schemes and cable lengths determine the type of communication port you need to use. In general RS-232 communications require that you place the 3808 transmitter within 25 feet of the ControlWave Corrector (local communications). You can use RS-485 communications to reach transmitters up to 4000 feet away (remote communications).

Figure 3-8 details RS-232 wiring connections required between the ControlWave Corrector and the 3808 transmitter.

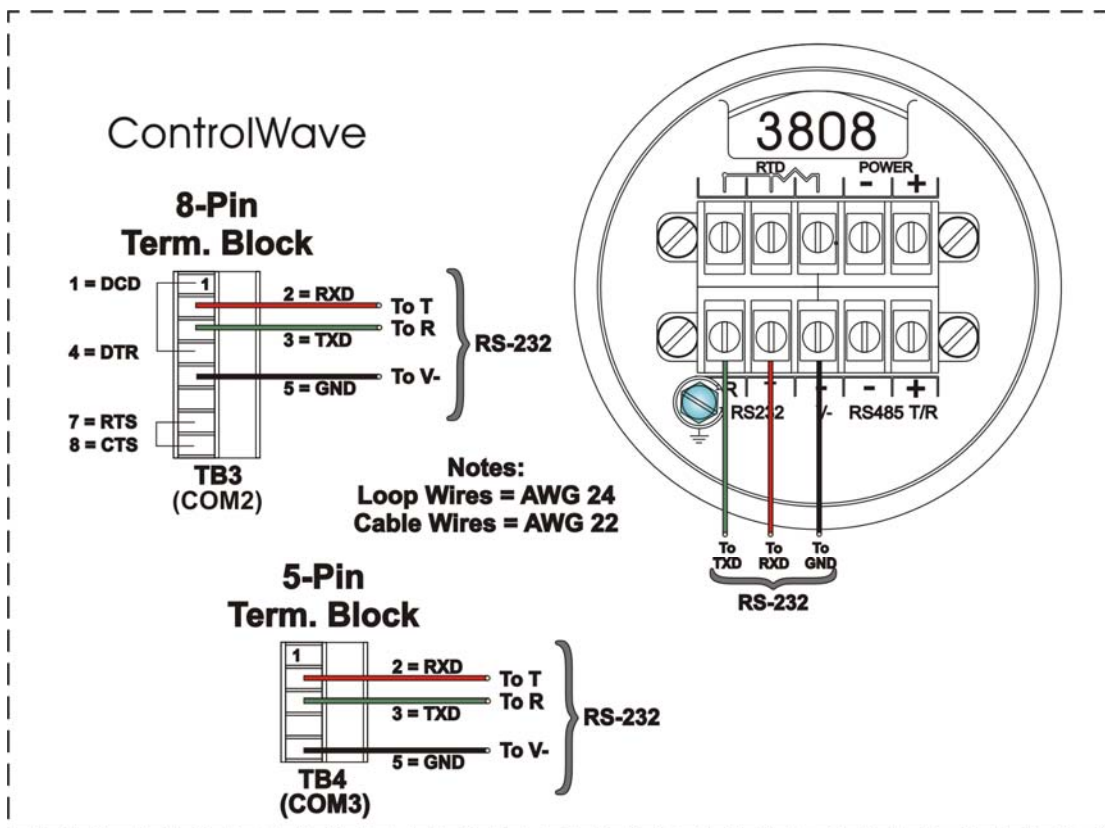

Figure 3-8. 3808 Transmitter to ControlWave Corrector RS-232 Comm. Cable Diagram

Figure 3-9 details RS-485 wiring connections required between the ControlWave Corrector and the 3808 transmitter.

Note: For loopback and termination control, use switch SW3 on the CPU/System Controller board to configure COM3. See Table 2-3.

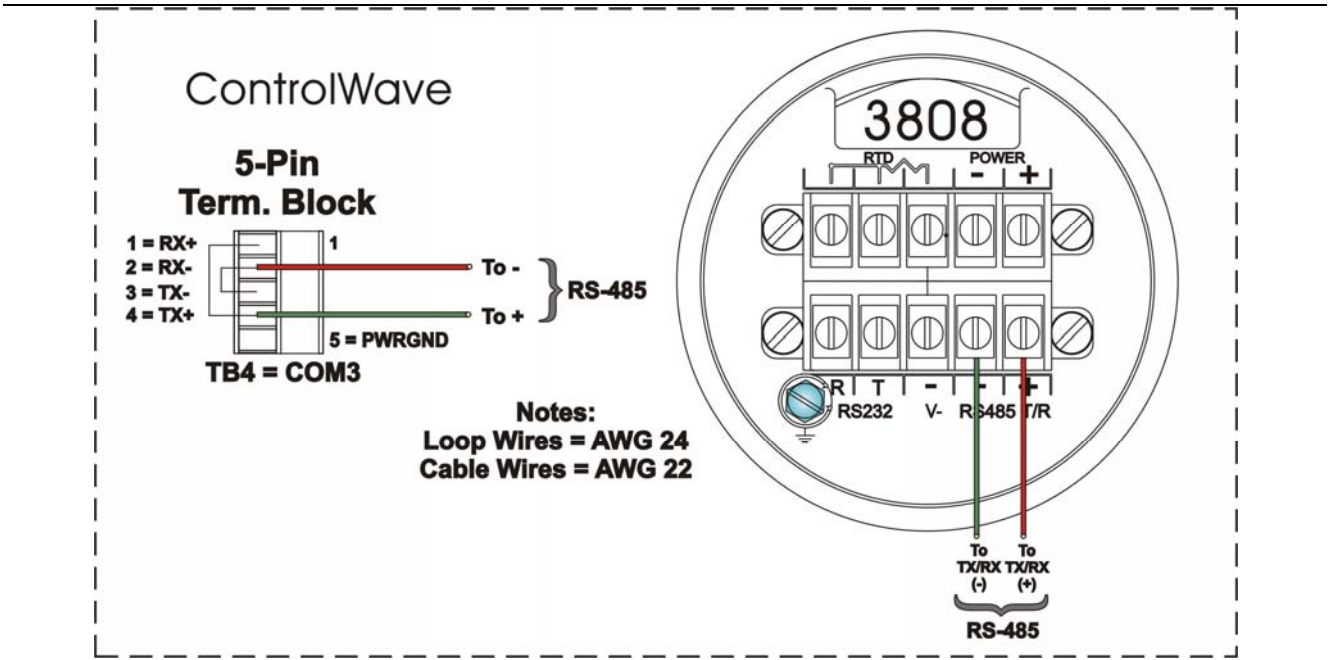

Figure 3-9. 3808 Transmitter to ControlWave Corrector RS-485 Comm. Cable

You can connect up to two 3808 transmitters to a ControlWave Corrector using a half-duplex RS-485 network. See Figure 3-10 for an illustration of this type of network.

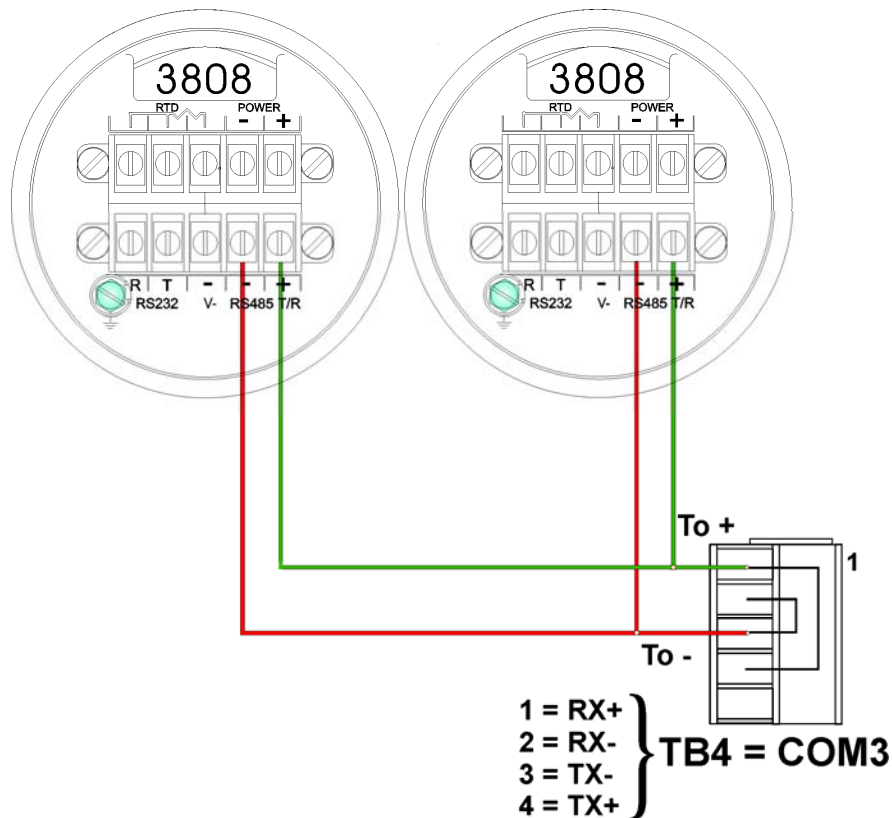

Figure 3-10. ControlWave Corrector to 3808s - RS-485 Network Diagram

This page is intentionally left blank

Chapter 4 – Operation

This chapter provides general operational details for using the ControlWave Corrector.

In This Chapter

4.1	Powering Up/Powering Down the ControlWave Corrector.....	4-1
4.2	Communicating with the ControlWave Corrector	4-2
4.2.1	Default Comm Port Settings.....	4-2
4.2.2	Changing Port Settings	4-3
4.2.3	Collecting Data from the ControlWave Corrector.....	4-3
4.3	Creating and Downloading an Application (ControlWave Project)..	4-3
4.4	Creating and Maintaining Backups.....	4-4
4.4.1	Creating a Zipped Project File (*.ZWT) For Backup	4-4
4.4.2	Saving Flash Configuration Parameters (*.FCP)	4-6
4.4.3	Backing up Data	4-7



WARNING EXPLOSION HAZARD

Substitution of components may impair suitability for use in Class I, Division 2 environments.

When the ControlWave Corrector is situated in a hazardous location, turn off power before servicing or replacing the unit and before installing or removing I/O wiring.

Do not disconnect equipment unless the power is switched off or the area is known to be non-hazardous.

See Appendix A for details on Class I Division 2 usage of this device.

4.1 Powering Up/Powering Down the ControlWave Corrector

The ControlWave Corrector receives power either from a solar panel and user-supplied battery or from an external bulk power supply attached using connector TB1 on the CPU/System Controller board. It can also receive power through alternate connector TB2 on the same board. *Chapter 2* includes instructions for wiring power to the ControlWave Corrector. See *Figure 2-3* for the location of these connectors.

Power Up To apply power to the ControlWave Corrector, plug in connectors TB1 and optionally TB2 on the CPU/System Controller board. If your ControlWave project resides in flash memory, the project will load into SRAM and begin execution. Depending upon the setting of the SRAM control switch, retain variable values may load as well.

⚠ Caution

When you disconnect power from the ControlWave Corrector, your running control strategy is erased from SRAM, as is any process data not stored in retention mode. When configured for retention and the backup battery remains good, SRAM stores the last states of all I/O points, audit/archive data not residing in FLASH, the values of all variables marked RETAIN, the values of variables stored in the static memory area, and any pending unreported alarm messages.

Power Down To remove power from the ControlWave Corrector, unplug connectors TB1 and TB2 from the CPU/System Controller board.

4.2 Communicating with the ControlWave Corrector

You communicate to the ControlWave Corrector by connecting a cable between a port on your PC workstation and one of the ControlWave Corrector ports.

The port at the PC workstation must match the configuration of the ControlWave Corrector port.

4.2.1 Default Comm Port Settings

As delivered from the factory, ControlWave Corrector communication ports have default settings. *Table 4-1* details these defaults.

Table 4-1. Default Comm Port Settings

Port	PCB	Default Configuration
COM1	CPU	RS-232; 115.2 Kbps using BSAP or ControlWave Designer protocol. Note: The local port at the bottom of the door is factory-wired to COM1.
COM2	CPU	RS-232; 9600 baud, 8 bits, no parity, 1 stop bit, BSAP or ControlWave Designer protocol
COM3	CPU	RS-485; 9600 baud, 8 bits, no parity, 1 stop bit, BSAP or ControlWave Designer protocol. Intended for use with Bristol 3808 transmitters. You use jumpers W12 through W16 to configure COM3 for either RS-232 or RS-485

Note: You can re-enable the factory communication settings at any time by setting CPU module switch SW2-3 to **OFF**.

Ethernet Using an optional Ethernet port (located on the 33MHz versions of the CPU module), you can connect either directly or through a network to a PC equipped with an Ethernet port. The default IP address and mask for the Ethernet port is:

- ETH1 IP Address: 10.0.1.1 IP Mask: 255.255.255.

4.2.2 Changing Port Settings

You change port settings (baud rate, port type, IP address, and so on) using the Flash Configuration utility.

You must establish communications with the ControlWave device using NetView, LocalView, or TechView before you can run the Flash Configuration utility.

Note: For detailed information on using the Flash Configuration utility, see *Chapter 5* of the *OpenBSI Utilities Manual* (D5081).



Caution

When you change the baud rate for a port, the baud rate changes as soon as you write the flash file changes to the RTU, and do not require a reset. For this reason, you should not change baud rate for the active port on which you are communicating, or communications will immediately stop due to the baud rate mismatch between the PC port and the controller port. If this happens accidentally, you can use CPU switch settings as discussed in the notes in Section 4.2.1 to restore defaults and re-establish communications.

4.2.3 Collecting Data from the ControlWave Corrector

OpenBSI utilities such as DataView, Data Array Save/Restore and Harvester allow you to collect real time data (values of variables, array values, alarm messages) and historical data (audit records, archive files) from the ControlWave. See the *OpenBSI Utilities Manual* (D5081) for details. SCADA software such as OpenEnterprise can then present this data to an operator in the form of graphical displays and reports.

4.3 Creating and Downloading an Application (ControlWave Project)

Most Corrector users purchase the ControlWave gas flow measurement application (ControlWave project) which ships pre-installed in the Corrector when it leaves the factory.

You can, however, create your own project using PC-based ControlWave Designer software. Instructions for creating a ControlWave project are beyond the scope of this manual. Please refer to the following sources for information:

- *Getting Started with ControlWave Designer* (D5085)
- *ControlWave Designer Programmer's Handbook* (D5125)
- ControlWave Designer online help

You must connect the Corrector to a PC running ControlWave Designer software and OpenBSI software.

Note: You can download an application either from ControlWave Designer or from the OpenBSI 1131 Downloader.

1. Connect a serial cable between your PC and COM1 of the ControlWave Corrector.
2. Define the ControlWave project in ControlWave Designer, and set communication and configuration parameters.
3. Download the project according to instructions in the *Downloading* section of the *ControlWave Designer Programmer's Manual* (D5125).

4.4 Creating and Maintaining Backups

You should always maintain a current backup of each ControlWave project and keep it in a safe place, preferably in a location physically separate from the controller.

The reason we recommend you keep backup files is that if a disaster occurs that damages or destroys your ControlWave hardware (flood, lightning strike, etc.) you don't want to also lose its control strategy software programs. Otherwise, when the unit is repaired or replaced, you'd have to create a new ControlWave project from scratch, which might take a lot longer than replacing a few damaged modules.

**Caution**

Always maintain a backup copy of your ControlWave project in a safe place.

Anytime you modify your ControlWave project, be sure to create a new backup of the new project.

Notes:

- You may find it useful to maintain more than one backup copy in case the backup media itself fails, for example, a CD-ROM becomes unreadable because it melted in the sun or a thumb drive fails because someone spilled coffee on it.
 - If you don't keep more than one backup copy, it's a good idea to periodically test your backup copy to verify that the media has not failed.
-

4.4.1 Creating a Zipped Project File (*.ZWT) For Backup

Note: The .zwt file is a complete backup of your entire project including code, comments and graphics. It may be stored on your PC or removable storage media. It may also be downloaded and archived to ControlWave Flash memory where it may be uploaded at a later time for editing.

With your current ControlWave project open in ControlWave Designer, perform the following steps:

1. Click **File > Save Project As / Zip Project As**.

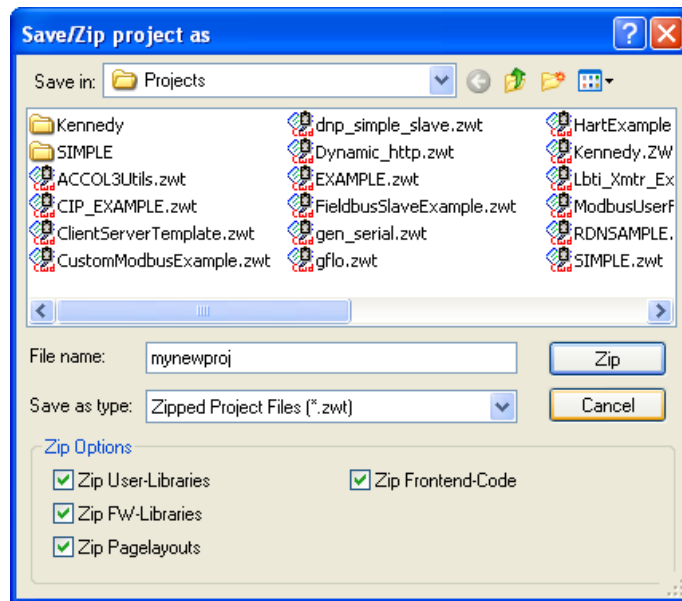

Figure 4-1. Saving a Backup of Your Project

2. In the “Save/Zip project as” dialog box, specify a project name in the **File name** field. In *Figure 4-1* we chose the name **mynewproj**.
3. In the **Save as type** field, choose **Zipped Project Files (*.zwt)**.
4. In the **Zip Options** area, select which additional files you want to include in the zwt file. Other than increasing the file size of the zwt, it doesn’t hurt to check any or all of these options.

Zip Option	Description
Zip User-Libraries	If you created your own user-defined functions or function blocks, you must select this to preserve them.
Zip Frontend-Code	If you selected Zip User-Libraries you should also select this option to include compiled code for libraries in your zip file. Otherwise, you need to re-compile your user libraries with the project when you unzip the zwt.
Zip FW-Libraries	This includes firmware libraries, such as ACCOL3.FWL in your zwt.
Zip Pagelayouts	This includes pagelayout information for printing your project, as well as graphical elements used in certain 1131 languages.

5. Click **Zip** and a progress bar displays the percent complete of the zipping process.
6. When the zip process completes, you’ll see a message box reporting successful completion. Click **OK**.

- Copy the resulting zwt file to backup media (CD-ROM, thumb drive, etc.) If you ever need to restore the project, just open the zwt file in ControlWave Designer, load libraries as needed, then compile the project and download it into the ControlWave.

4.4.2 Saving Flash Configuration Parameters (*.FCP)

You must establish communications with the ControlWave Corrector using NetView, LocalView, or TechView before you can run the Flash Configuration utility.

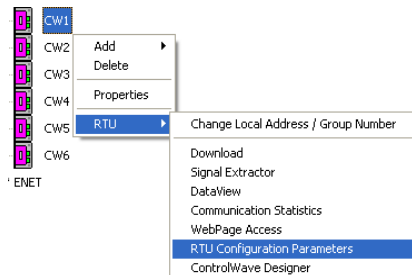

Note: For detailed information on using the Flash Configuration utility, see *Chapter 5 of the OpenBSI Utilities Manual (D5081)*.

- Start the Flash Configuration utility. To do this in NetView or LocalView, *right-click* on the icon for this ControlWave and choose **RTU > RTU Configuration Parameters**.

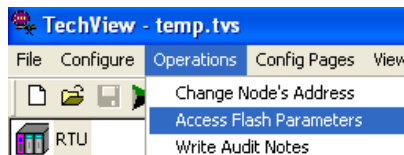

To do this in TechView, click **Operations > Access Flash Parameters** or click the Access Flash icon .



- Depending upon how your system is configured, the Flash Configuration – Loading Options dialog box may open. If it does, choose **Load from device** and wait for the utility to retrieve all parameters from the ControlWave Corrector, then skip to step 4, otherwise, just proceed to step 3.
- Click  and wait for the utility to retrieve all parameters from the ControlWave.
- Click  and specify a name for your FCP file, then click **Save**. When the status line indicates successful completion, your FCP file is done.
- Copy the resulting FCP file to backup media (CD-ROM, thumb drive, etc.) If you ever need to restore the FCP parameters to the controller, establish communications with the unit, start the

Flash Configuration utility, and load the FCP file using the **Read from FCP** button, then choose the **Write to RTU** button.

4.4.3 Backing up Data

You can back up certain types of data and restore it if needed. There are other types of data that you can only collect, but you cannot restore.

- If you have certain variables that represent tuning parameters (setpoints, for example) you can use tools such as the OpenBSI DataView recipe feature to save those values to a recipe file on the PC, and then restore them at a later time. See *Chapter 8* of the *OpenBSI Utilities Manual (D5081)*.
- You can store the contents of read/write data arrays using the OpenBSI Data Array Save/Restore utility. See *Chapter 13* of the *OpenBSI Utilities Manual (D5081)*.
- You can collect alarms, and historical data (audit records, archive files) but you cannot restore alarms or historical data.

This page is intentionally left blank

Chapter 5 – Service and Troubleshooting

This chapter provides general diagnostic and test information for the ControlWave Corrector as well as some common maintenance procedures.

In This Chapter

5.1	Upgrading Firmware	5-2
5.2	Removing or Replacing Components.....	5-6
5.2.1	Accessing Modules for Testing	5-6
5.2.2	Removing/Replacing the CPU/System Controller Board and the Process I/O Board	5-6
5.2.3	Removing/Replacing the Primary Battery System	5-7
5.2.4	Removing/Replacing the Backup Battery	5-8
5.2.5	Enabling / Disabling the Backup Battery	5-9
5.2.6	Removing/Replacing the Case-Mounted Radio or Modem	5-9
5.2.7	Removing/Replacing the GPT Transducer	5-10
5.2.8	Removing/Replacing the TeleCounter (Pulser) Assembly.....	5-10
5.3	General Troubleshooting Procedures	5-11
5.3.1	Common Communication Configuration Problems.....	5-11
5.3.2	Checking LEDs.....	5-12
5.3.3	Checking LCD Status Codes	5-12
5.3.4	Wiring/Signal Checks	5-12
5.4	WINDIAG Diagnostic Utility	5-13
5.4.1	Available Diagnostics	5-14
5.5	Core Updump	5-17
5.6	Calibration Checks.....	5-18

Equipment You need the following equipment to perform the procedures described in this chapter:

To run diagnostics software:

- PC with WINDIAG software, and either OpenBSI LocalView, NetView, or TechView for communications
- Null modem interface cable
- Loop-back plug (See *Figure 5-6* and *Figure 5-7*.)

To perform firmware upgrades:

- Null modem interface cable
- PC with the following software:
 - o OpenBSI LocalView
 - o OpenBSI System Firmware Downloader and either NetView, LocalView, or TechView for communications.
 - o HyperTerminal (included in Windows®)

To replace the SRAM backup battery:

- Tweezers or needle-nose pliers

Miscellaneous other equipment:

- Needle-nose pliers

- Screw drivers
- Anti-seize compound (when replacing GPT/MVT)

Note: When you service a ControlWave Corrector on site, we recommend that you close down (or place under manual control) any associated processes. This precaution prevents any processes from accidentally running out of control when you conduct tests.



Caution

Harmful electrical potentials may still exist at the field wiring terminals even though the ControlWave Corrector power source may be turned off or disconnected. Do not attempt to unplug termination connectors or perform any wiring operations until you verify that all associated power supply sources are turned off and/or disconnected.

Always turn off any external supply sources for externally powered I.O circuits before you change any modules.



WARNING

EXPLOSION HAZARD

Substitution of components may impair suitability for use in Class I, Division 2 environments.

When the ControlWave Corrector is situated in a hazardous location, turn off power before servicing or replacing the unit and before installing or removing I/O wiring.

Do not disconnect equipment unless the power is switched off or the area is known to be non-hazardous.

See Appendix A for details on Class I Division 2 usage of this device.

5.1 Upgrading Firmware

The ControlWave Corrector ships from the factory with system firmware already installed. If you need to upgrade the system firmware (stored in Flash memory) to acquire new functionality or restore firmware, you can use one of several methods.

**System
Firmware
Downloader**

Use this tool to download system firmware to an unattended remote ControlWave Corrector. To use this utility, you must set CPU/System Controller board switch SW2-6 **ON** (the factory default position).

Note: For further information and detailed use instructions, refer to *Appendix J* of the *OpenBSI Utilities Manual* (D5081).

LocalView

One of the standard OpenBSI utilities, LocalView requires OpenBSI version 5.1 (or newer). If you have an older version of OpenBSI, use HyperTerminal.

Note: For further information and detailed use instructions, refer to the Flash Mode section of *Chapter 5* of the *OpenBSI Utilities Manual* (D5081).

HyperTerminal HyperTerminal is a communications utility program included with Microsoft® Windows® XP.

Notes:

- If you are using a version of OpenBSI older than 5.1, or do not have OpenBSI software, you can only perform a firmware upgrade using HyperTerminal.
 - While HyperTerminal is included in Microsoft® Window® XP, some newer versions of Window® do not include it.
 - The screens shown here may appear different depending upon the version of HyperTerminal you use.
 - HyperTerminal requires *.BIN files; newer ControlWave firmware upgrade files use *.CAB files. In cases such as those, you should use the Remote System Firmware Downloader.
-

1. Connect a null modem cable between COM1 of the ControlWave Corrector and any RS-232 port on the associated PC.
2. Click **Start > Programs > Accessories > Communications > HyperTerminal**
3. If using HyperTerminal for the first time, set the communication properties (for the PC port) via the Properties Menu as follows: Bits per second: = 115200, Data bits: = 8, Parity: = None, Stop bits: = 1, and Flow control: = None and then click **OK**.
4. Set CPU/System Controller board switch SW1-3 **ON** (ON = Force Recovery).
5. Apply power; to the ControlWave Corrector. The resident BIOS initializes and tests the hardware, this process is referred to as POST (Power On Self Test). Unless there is a problem, the LCD display should show RECOV. If you see a different status code, see *Section 5.3.2*.
6. From the HyperTerminal Mode menu (*Figure 5-1*), press the **F** key to enter FLASH download. A message warns that the FLASH is about to be erased; press the **Y** key at the prompt. The screen displays dots as the system erases the flash memory; this could take a few minutes.

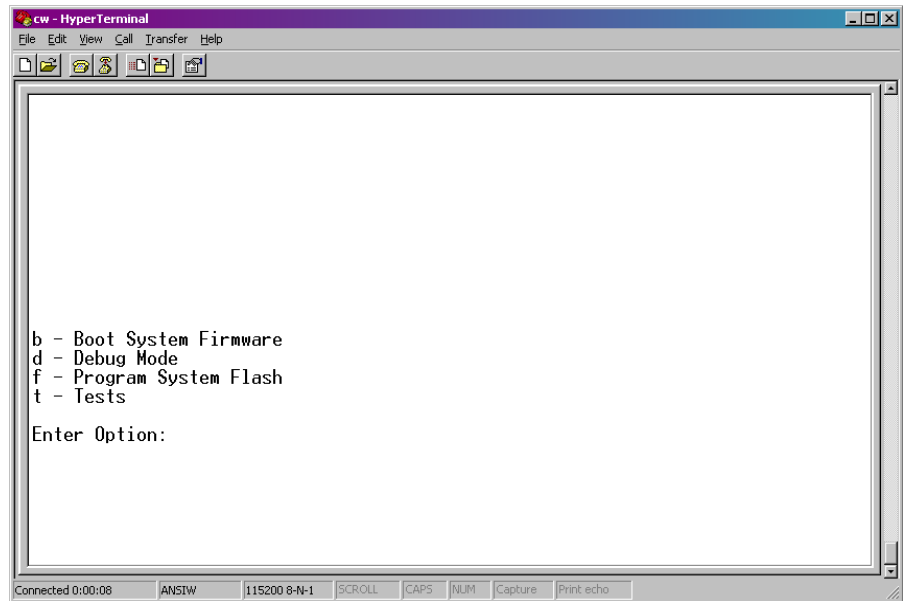

Figure 5-1. HyperTerminal Mode Menu

7. When the FLASH is ready for download, HyperTerminal repeatedly displays the letter C on the screen. In the HyperTerminal menu bar click **Transfer > Send File** (see Figure 5-2).

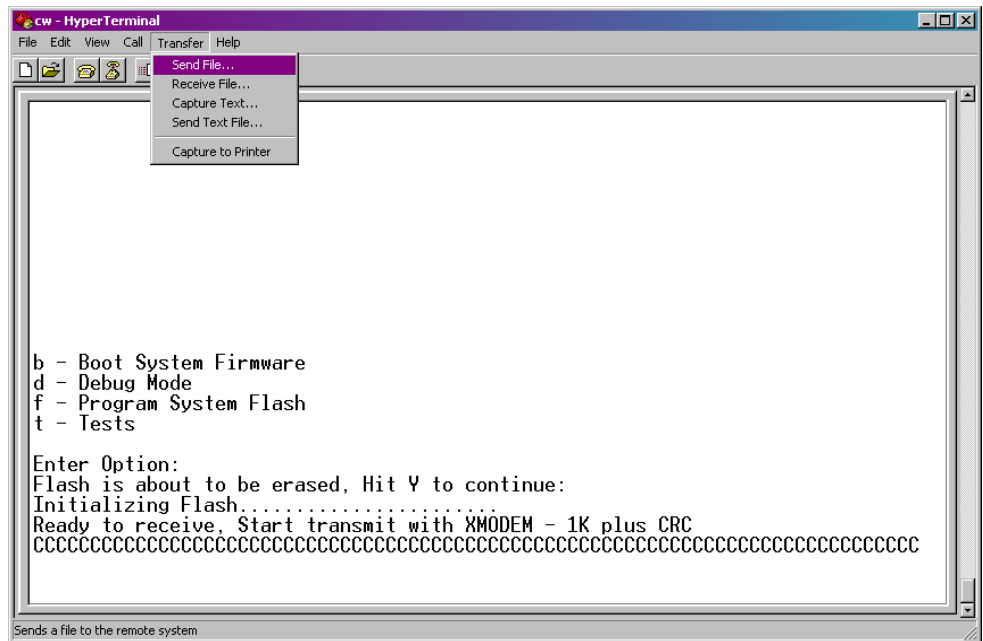

Figure 5-2. HyperTerminal (Ready to Download)

8. In the Send File dialog box (see Figure 5-3), select **1KXmodem** for the protocol, enter the filename of the appropriate .bin file in the format “E1Sxxxxx.bin” or “E3Sxxxxxx.bin” (where E1S refers to 14 MHz CPUs, and E3S refers to 33 MHz CPUs and

xxxxx varies from release to release) and click **Send** to start the flash upgrade (see *Figure 5-4*). When you see the HyperTerminal Mode Menu again, it means the download has completed.

9. Exit HyperTerminal and power down the ControlWave. If desired, you can disconnect the null modem cable between the ControlWave Corrector and the PC.
10. Set switch SW1-3 to the **OFF** position (OFF = Recovery Mode Disabled).
11. Restore power to the ControlWave.

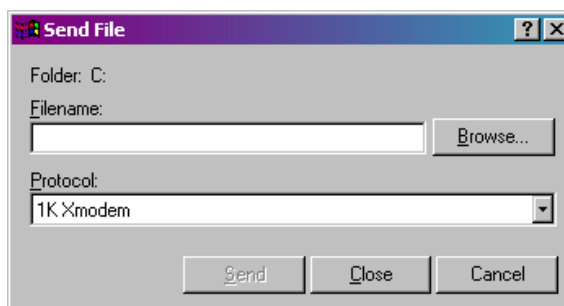

Figure 5-3. Send File dialog box

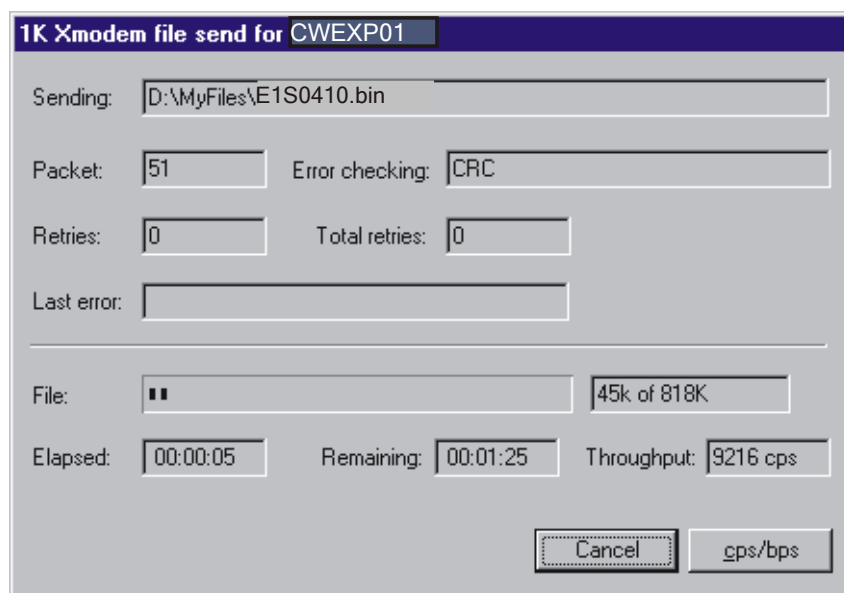

Figure 5-4. HyperTerminal (Download in Progress)

5.2 Removing or Replacing Components

This section provides information on accessing ControlWave Corrector components for testing, as well as removal/replacement procedures.



Caution

Field repairs to the ControlWave Corrector are strictly limited to the replacement of complete boards. Replacing board components constitutes tampering and violates the product warranty. Return defective boards or housings to the factory for authorized service.

5.2.1 Accessing Modules for Testing

Only technically qualified personnel should test and/or replace ControlWave Corrector components. Read completely the disassembly and test procedures described in this manual before starting. Any damage to the ControlWave Corrector resulting from improper handling or incorrect service procedures is not covered under the product warranty agreement. If you cannot properly perform these procedures, obtain authorization and then return the device to the factory for evaluation and repairs.

5.2.2 Removing/Replacing the CPU/System Controller Board and the Process I/O Board

Use this procedure to remove or replace the CPU/System Controller board and the Process I/O board.

1. If the ControlWave Corrector is running, place any critical control processes under manual control.
2. Open the cover and shut down the ControlWave Corrector by disconnecting the power at the CPU/System Controller assembly terminal TB1 (and if applicable, TB2).
3. Disconnect all removable card edge connectors from the CPU/System Controller board and the Process I/O board. Label or otherwise identify them so you can easily re-connect them later.
4. If present, disconnect the display/keypad from connector J2 on the CPU/System Controller board.
5. Loosen the upper and lower locking tabs and rotate them so you can remove the boards together. Carefully slide the boards toward the front of the unit and unplug the GPT cable from the CPU/System Controller board connector P1.
6. If you need to replace either the CPU/System Controller board or Process I/O board, you need to separate the two boards. Use a pair of needle-nosed pliers to squeeze the pair of tabs associated with each of the six nylon mounting posts, while gently pulling the CPU/System Controller board away from the Process I/O board. Carefully unplug the boards from their interface

connectors. Align the replacement boards with each other and press them together so that the interface connectors and mounting posts properly mate; then squeeze together so that the mounting post tabs capture the CPU/System Controller board.

7. To install the replacement boards, power must be off. Align the Process I/O board with the upper and lower guides so that the CPU/System Controller board is on the right side. Slide the boards (assembly) into the unit, making sure to re-connect the GPT cable to CPU/System Controller board connector P1 before you fully insert the assembly.
8. Rotate the upper and lower locking tabs to secure the boards.
9. Replace all cables removed in steps 3 through 6.
10. Apply power and test the unit.

5.2.3 Removing/Replacing the Primary Battery System

Notes:

- The primary battery system attaches to the inside of the battery cover/radio mounting plate.
 - Make sure the replacement battery is fully charged before you install it.
-

1. If the ControlWave Corrector is running, place any critical control processes under manual control.
2. Open the cover and shut down the ControlWave Corrector by disconnecting the power at the CPU/System Controller assembly terminal TB1 (and if applicable, TB2).
3. Remove the battery wires from the CPU/System Controller board connector TB1 (unplugged in step 2) making sure they don't contact each other.
4. Loosen the four screws that secure the battery cover/radio mounting plate to the one-piece mounting bracket.
5. Slide the battery cover/radio mounting plate towards the top of the unit so that its slots clear the mounting screws, and remove it. If a radio or modem is present, carefully set the battery cover/radio mounting plate to one side.
6. Carefully remove the primary battery system (with cables attached).
7. To replace the primary battery system, reverse the steps you performed from step 6 to step 3.
8. Apply power and test the unit.

5.2.4 Removing/Replacing the Backup Battery

Note: The CPU/System Controller board draws power from the battery only if the board loses power. The system SRAM has a standby current draw of 20 μ A maximum for each part plus 2 μ A for the real time clock. For a ControlWave Corrector containing 2MB of SRAM, a worst-case current draw of 42 μ A allows a battery life of approximately 9000 hours. This means you should not need to replace a battery until the ControlWave Corrector has been in service for an extended period (normally many years).

The CPU/System Controller board accommodates a 3 V, 300 mA lithium coin cell backup battery housed in a coin-cell socket (S1). A supervisory circuit on the CPU switches to battery power when the regulated 3.3 Vdc falls out of specification. The battery then provides backup power for the real-time clock (RTC) and the system SRAM on the CPU/System Controller board.

Note: If the backup battery is working properly, the `_BAT_OK` system variable is set ON; if the battery fails, this is OFF. The Ram Backup Battery Status shows on the Station Summary page in the standard measurement application. If the real-time clock loses its battery backup, the ControlWave system variable `_QUEST_DATE` turns ON. You can monitor this to generate an alarm. See the *System Variables* section of the *ControlWave Designer Programmer's Handbook* (D5125) for more information. See the *ControlWave Flow Measurement Applications Guide* (D5137) for information on the standard measurement application.

 **Caution** You lose SRAM contents when you remove the backup battery.

If you replace a backup battery, wait at least one minute before re-powering the system. This enables the SRAM to completely discharge.

After you install the new battery, ensure that you have placed jumper W3 on pins 1-2 (to enable the battery).

**Removing /
Replacing the
Backup Battery**

1. If the ControlWave Corrector is running, place any critical control processes under manual control.
2. Remove power from the ControlWave Corrector.
3. Remove the CPU/System Controller board assembly from the housing.

To remove the lithium battery, gently pry up the tab holding the battery in the coin cell socket and remove the battery with a pair of tweezers or needle-nosed pliers. Install the replacement battery.

4. Replace the CPU/System Controller board assembly in the housing.
5. Re-connect power to the ControlWave Corrector.
6. Once the battery has been replaced, the unit executes its Flash-based application (“boot project”) at power-up, but all of the current process data is lost. At power-up, the ControlWave Corrector acts as though it had just been booted and reverts back to the initial values specified in its application.

5.2.5 Enabling / Disabling the Backup Battery

For maximum shelf life, the CPU/System Controller board ships from the factory with the installed lithium backup battery disabled. You must enable it when you install the CPU/System Controller board.

Enabling To enable the battery, install jumper W3 on pins 1-2.

Disabling For maximum shelf life, you can isolate the battery from the circuit by placing jumper W3 on pins 2-3.

5.2.6 Removing/Replacing the Case-Mounted Radio or Modem

1. If the ControlWave Corrector is running, place any critical control processes under manual control.
2. Open the cover and shut down the ControlWave Corrector by disconnecting the power at the CPU/System Controller assembly terminal TB1 (and if applicable, TB2).
3. Disconnect (unplug/unscrew) all power and interface connectors from the radio/modem.
4. Disconnect the antenna cable from the radio.
5. Loosen the four screws that secure the battery cover/radio mounting plate to the one-piece mounting bracket.
6. Slide the battery cover/radio mounting plate towards the top of the unit, and remove it with the radio/modem installed.
7. Remove the mounting screws from the inner side of the battery cover/radio mounting plate to remove the radio/modem. **Note:** If the unit has a Bristol 9600 bps PSTN modem you also have to

remove four screws that mount it to a plate which in turn mounts to the radio/modem mounting plate.

8. Replace the radio/modem, reversing the steps from 7 to 3.
9. Apply power and test the unit.

5.2.7 Removing/Replacing the GPT Transducer

1. If the ControlWave Corrector is running, place any critical control processes under manual control.
2. Open the cover and shut down the ControlWave Corrector by disconnecting the power at the CPU/System Controller assembly terminal TB1 (and if applicable, TB2).
3. Remove the ControlWave Corrector from its installation site and take it to a repair area that supports proper ESD (electrostatic discharge) control.
4. Remove the 4mm Hex cap screw from the mounting collar and slowly pull out the GPT transducer. Carefully unplug the cable from the GPT transducer.
5. Prior to installation of a replacement GPT, make sure that the GPT O-ring seal is in place. Reverse the instructions from step 4 through step 1.

5.2.8 Removing/Replacing the TeleCounter (Pulser) Assembly

1. Configure the replacement TeleCounter assembly.
2. If the ControlWave Corrector is running, place any critical control processes under manual control.
3. Open the cover and shut down the ControlWave Corrector by disconnecting the power at the CPU/System Controller assembly terminal TB1 (and if applicable, TB2).
4. Remove the ControlWave Corrector from its installation site and take it to a repair area that supports proper ESD (electrostatic discharge) control.
5. Disconnect the TeleCounter interface wiring from the CPU/System Controller board and the Process I/O board.
6. Remove the four (4) screws which secure the TeleCounter assembly to the base of the ControlWave Corrector.
7. While securing the ControlWave Corrector assembly, remove the nuts that secure the base of the TeleCounter assembly to the turbine meter and remove the TeleCounter.
8. While securing the ControlWave Corrector assembly, install the replacement TeleCounter assembly (with top gasket) to the base of the unit such that the wiring harness runs through the large

hole at the base of the unit's housing. Install and tighten the four screws that secure the TeleCounter to the bottom of the ControlWave Corrector's housing.

9. Install a new gasket to the top of the turbine meter and mount the ControlWave Corrector. When mating the Corrector to the turbine meter, it is essential that the input shaft of the TeleCounter and the opening of the output shaft of the turbine meter mate properly. Be careful not to damage the mating surfaces. Once you align the surfaces, install and tighten the mounting washers and nuts.
10. Connect the replacement TeleCounter wires to the CPU/System Controller board.

5.3 General Troubleshooting Procedures

This section presents some procedures to troubleshoot problems with the Corrector.

5.3.1 Common Communication Configuration Problems

If serial communications do not function, it is often due to one of the following issues:

- Baud rate mismatch – the baud rate at both ends of the communication line must match. If communications fail during a download of a new flash configuration profile (FCP) file, you may have changed the baud rate of the active communication line, since baud rate changes occur immediately on FCP download. You can always re-establish factory default baud rates for communication ports by powering down the unit, and then setting CPU switch SW2-3 to **OFF** and restoring power.
- Incorrect BSAP local address – this address must be an integer from 1 to 127 and must be unique on this particular BSAP communication line. You set the BSAP local address using the flash configuration utility. If this ControlWave is a BSAP slave node, and the range of addresses defined for the BSAP master port end of the communication line does not encompass the local BSAP address defined for this ControlWave, BSAP communications will not function.
- Incorrect EBSAP Group number – if you use expanded BSAP the EBSAP group number must be correct; if you are not using EBSAP, the group number must be 0.

If IP communications do not function, it is often due to incorrect IP addresses or masks. Check to see that the IP address you defined for the ControlWave is compatible with the range of IP addresses defined for the communication line on which the unit resides. Also check that the IP address of the default gateway is correct.

5.3.2 Checking LEDs

The ControlWave Corrector includes two red light emitting diodes (LEDs) that provide operational and diagnostic functions.

You must open the chassis door to view these LEDs.

Table 5-1. LEDs on CPU/System Controller Board

LED	Color	Description
WD (CR1 right)	RED	ON = Watchdog condition – program crash; OFF = Normal operation
IDLE (CR1 left)	RED	ON = CPU has free time at end of execution cycle. Should be on frequently. OFF = CPU overloaded. Note: The idle LED may also be off if you disabled it - see <i>Table 2-1</i> in Chapter 2.

5.3.3 Checking LCD Status Codes

The following codes may appear on the LCD display:

Table 5-2. LCD Display Status Codes

LCD Display	Indication Definition
Blank	Application Running
DIAG	Unit in Diagnostic Mode
R DIAG	Unit Running Diagnostics
FWXSUM	Flash XSUM Error
DEVERR	Error Initializing Application Device
FLASH	Flash Programming Error
FACT	Using Factory Defaults
BATT	Battery Failure Detected
STRUP	Currently Loading the Boot Project
INIT	System Initialization in Progress
RECOV	Waiting in Recovery Mode
RAMERR	Error Testing SRAM
STOP	Application Loaded
HALT	Stopped at a Break Point
NO APP	No Application Loaded
BREAKP	Running with Break Points
POWERD	Waiting for Power-down (after NMI)
UPDUMP	Waiting for Updump to be Performed
NOTRUN	Unit Crashed (Watchdog Disabled)

5.3.4 Wiring/Signal Checks

- Check I/O field wires at the card edge terminal blocks and at the field device.
- Check wiring for continuity, shorts and opens.
Check I/O signals at their respective terminal blocks.

5.4 WINDIAG Diagnostic Utility

**Caution**

The ControlWave Corrector cannot execute your control strategy while it runs diagnostic routines; place any critical processes controlled by the ControlWave Corrector under manual control before starting this procedure.

WINDIAG is a software-based diagnostic tool you use to test the performance of I/O, CPU memory, communication ports, and other system components. .

WINDIAG is a PC-based program, so the ControlWave Corrector must be attached to and communicating with a PC running WINDIAG. Establish communication between the ControlWave Corrector (with/without an application loaded) and the PC with a local or network port under the following conditions:

- Set CPU module switches SW2-3 to **OFF** and SW2-8 to **OFF**. Turning these switches off sets all serial ports on the ControlWave Corrector to 9600 baud in preparation for diagnostic testing and prevents the boot project from running and also places the ControlWave Corrector in diagnostic mode.
- Connect any ControlWave Corrector serial communication port to the PC provided their port speeds match. Use a null modem cable to connect RS-232 ports between the ControlWave Corrector and the PC; use an RS-485 cable to connect the RS-485 port of the ControlWave Corrector and the PC. See *Chapter 2* for information on cables.
- Reserve the port running a diagnostic test for exclusive use; you cannot use that port for any other purpose during testing.

Follow these steps:

1. Start OpenBSI communications using NetView, TechView, or LocalView, and select the RTU you want to test.
2. Select **Start >Programs > OpenBSI Tools >Common Tools >Diagnostics**. The Main Diagnostics menu (*Figure 5-5*) opens.

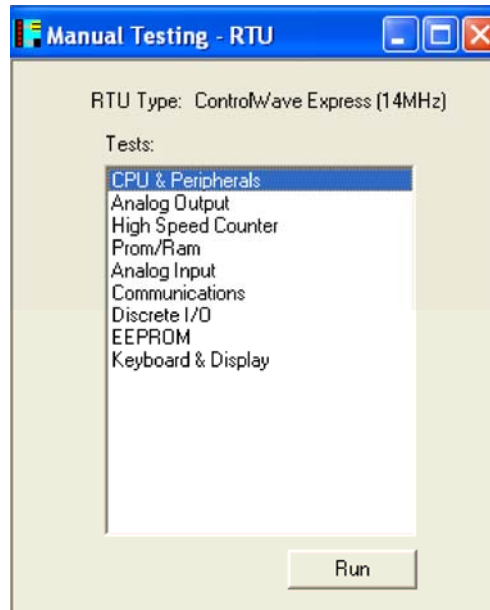

Figure 5-5. WINDIAG Main Diagnostics Menu

3. Select the component to be tested. See *Section 5.4.1* for a description of the tests. Enter any prompted parameters (slot #, etc.). WINDIAG performs the diagnostics and displays pass/fail results.

After performing all diagnostic testing, exit WINDIAG.

4. Set switches SW2-3 and SW2-8 on the CPU module to **ON**. The ControlWave Corrector should resume normal operation.

5.4.1 Available Diagnostics

WINDIAG's Main Diagnostics Menu (see *Figure 5-5*) provides the following diagnostic selections:

Option	Tests
CPU & Peripherals	Checks the CPU/System Controller board except for memory.
Analog Output	Checks the AO on the Process I/O board.
High Speed Counter	Checks HSCs on the Process I/O board and Pulse Counter inputs on the CPU/System Controller board.
Prom/Ram	Checks the SRAM and FLASH memory.
Analog Input	Checks AIs on the Process I/O board.
Communications	Checks serial communication ports COM1, COM2, and COM3. The External loop-back tests require the use of a loop-back plug.
Discrete I/O	Checks DIs and DOs on the Process I/O board.
EEPROM	Checks the EEPROM.
Keyboard & Display	Checks the optional display/keypad hardware.

Port Loop-back Test WINDIAG allows you to select the communication port to test. Depending on the type of network (RS-232 or RS-485) and the port in question, a special loop-back plug is required:

- Port 1 - RS-232 uses a 9-pin female D-type loop-back plug (see *Figure 5-6*).

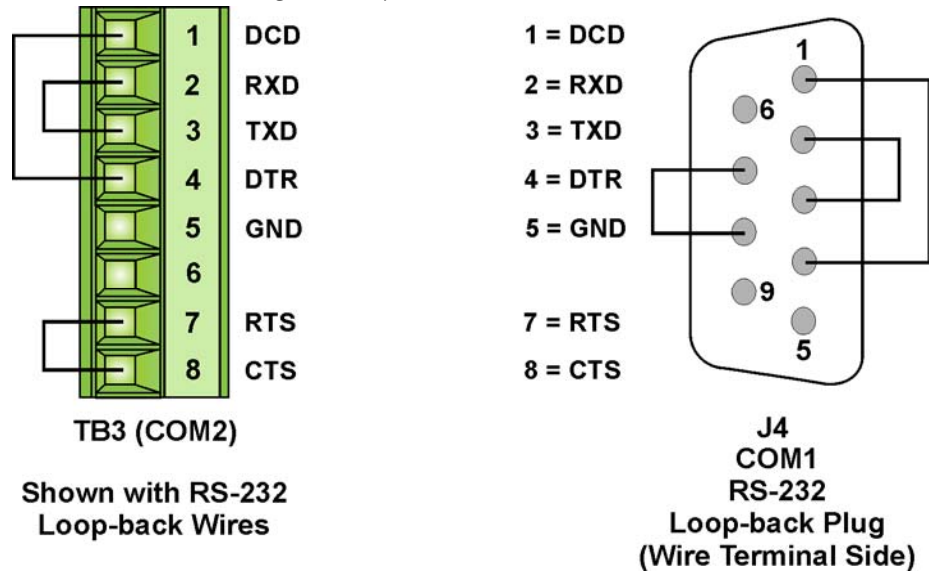

Figure 5-6. COM1 & COM2 RS-232 Loop-back Plug/Wires

- Port 2 - RS-232 use loop-back wires (see *Figure 5-6*).
- Port 3 - RS-232 use loop-back wires (see *Figure 5-7*).

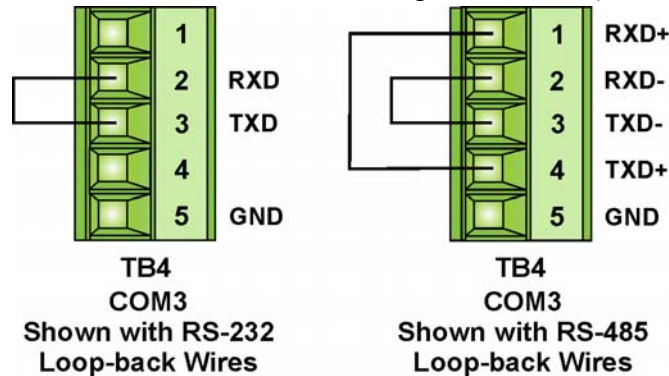

Figure 5-7. COM3 RS-232 & RS-485 Loop-back Wires

Note: You can configure RS-485 loopback by setting CPU/System Controller board switches SW3-1 & SW3-2 **ON**.

- Port 3 - RS-485 use loop-back wires or CPU Switch SW3 (see *Figure 5-7*).

These tests verify the correct operation of the communication ports.

Note: You **cannot** test a communications port while you are using it.

You can only test currently unused ports. After you complete testing on all other communication ports (and verify their correct functioning), you must reconnect (using a now validated port) and test the remaining untested port.

Test Procedure Use this procedure to test the communication ports.

1. Connect an external loop-back plug to the port on the CPU you want to test. Valid ports are: **COM1**, **COM2**, or **COM3**.
2. Select **Communications** on the WINDIAG Main Diagnostics Menu. The Communications Diagnostic screen opens:

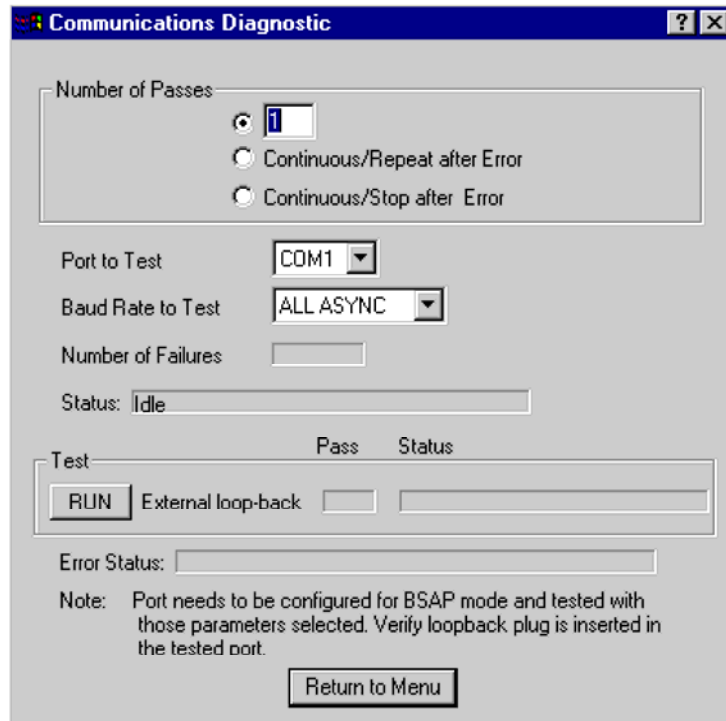

Figure 5-8. Communications Diagnostic Menu

3. Enter **5** in the Number of Passes field.
4. Select a port to test (click ▼ to display all available ports).

Note: The port you select must correlate to the port on which you placed the loop-back plug in step 1.

5. Select **115200** or **ALL ASYNC** as the baud rate (click ▼ to display all available rates).
6. Click **RUN** to start the test. At the completion of the test (which generally takes about 5 seconds), any failed results appear in the Status field to the right of the RUN button: For example:
 - TXD RXD Failure
 - CTS RTS Failure
7. Click **Return to Menu** to display the WINDIAG Main Menu.

5.5 Core Updump

In some cases—such as when a ControlWave Corrector fails for no apparent reason—you can upload a copy of the contents of SRAM and SDRAM to a PC for support personnel and service engineers to evaluate. This upload is called a “core updump.”

A core updump may be required if the ControlWave Corrector spontaneously enters a watchdog state that affects all system operation. This occurs when the system crashes as a result of a CPU timeout (resulting from improper software operation, a firmware glitch, and so on). In some cases, the watchdog state can recur but you cannot logically reproduce the conditions.

The CPU’s RAM contains “crash blocks,” a firmware function provided specifically for watchdog troubleshooting. You can view and save the crash blocks by viewing the Crash Block Statistic Web Page (see the *Web_BSI Manual*, D5087). On request, you can forward crash block files to our technical support personnel. If they need additional information to evaluate the condition, the technical support group may request a core updump. Once the core updump process generates a file, you can forward that file to the support personnel for evaluation and resolution.

Use the following steps to preserve the “failed state” condition at a system crash and perform a core updump:

1. Set switch SW2-1 on the CPU/System Controller board to **OFF** (Disable Watchdog Timer). Set switch SW2-4 to **OFF** (Enable Core Updump).

Note: The factory default setting for switch SW2-4 is **OFF**.

2. Wait for the error condition (typically “NOTRUN” on the LCD display).
3. Connect the ControlWave Corrector’s Comm Port 1 to a PC using a null modem cable.
4. Set the ControlWave Corrector for Recovery Mode by setting **both** SW1-1 and SW1-2 to **either** the **ON** position **or both** to the **OFF** position..
5. Start the PC’s HyperTerminal program (at 115.2 kbaud) and generate a receive using the 1KX-Modem protocol. Save the resulting core updump in a file so you can forward it later to the technical support group.

By setting the CPU/System Controller board switches SW2-1 and SW2-4 both off **before** the ControlWave Corrector fails you prevent the Corrector from automatically recovering from the failure and enable it to wait for you to take a core updump.

Once you complete the core updump, set the CPU/System Controller

board's switch SW2-1 to **ON** (Watchdog Enabled) and SW2-4 to **ON** (Core Updump Disabled).

Additionally, set switch SW1-1 to **OFF** and SW1-2 to **ON**.

With these switches set, power up the ControlWave Corrector and begin standard operations.

5.6 Calibration Checks

The AO and AI on the Process I/O board are self-calibrating.

To calibrate the MVT/GPT and the RTD, use TechView software. See the *TechView User's Guide* (D5131) for more information.

Appendix A – ControlWave Corrector– Special Instructions for Class I, Division 2 Hazardous Locations

1. The ControlWave Corrector is listed by Underwriters Laboratories (UL) as nonincendive and is suitable for use in Class I, Division 2, Groups C and D hazardous locations or non-hazardous locations only. Read this document carefully before installing a nonincendive ControlWave Corrector. Refer to *CI-ControlWave Corrector* for general information. In the event of a conflict between the ControlWave Corrector Instruction Manual (*CI-ControlWave Corrector*) and this document, always follow the instructions in this document.
2. The ControlWave Corrector includes both nonincendive and unrated field circuits. Unless a circuit is specifically identified in this document as nonincendive, the circuit is unrated. Unrated circuits must be wired using Div. 2 wiring methods as specified in *Article 501-4(b)* of the *National Electrical Code (NEC)*, *NFPA 70* for installations in the United States, or as specified in *Section 18-152* of the *Canadian Electrical Code* for installation in Canada.
3. The local communications port terminates in a circular 5-pin connector on the bottom of the ControlWave Corrector's front cover. The wiring on this connector is unrated. No connections may be made to this port unless the user ensures that the area is known to be nonhazardous. Connections to this port are temporary, and must be short in duration to ensure that flammable concentrations do not accumulate while it is in use.
4. The optional power system (solar panel and battery) approved for use with the nonincendive ControlWave Corrector are described in the model specification. The connection to the solar panel is approved as a nonincendive circuit so that Division 2 wiring methods are not required. The nominal panel voltage must match the nominal battery voltage (6V or 12V).
5. An RTD is normally supplied with the ControlWave Corrector. Connection to the RTD is approved as a nonincendive circuit, so that Division 2 wiring methods are not required.
6. Signal connectors available for customer wiring are listed in *Table A-1*. Network communications port and I/O wiring connections are unrated and must be wired using Division 2 wiring methods.

7. The UL listed nonincendive ControlWave Corrector may include radio/modem communications (listed on the model specification) that is used in conjunction with a 5W, 12V, 7AH lead acid battery system. Connection to the radio or modem is approved as a nonincendive circuit, so that Division 2 wiring methods are not required.

 **WARNING** EXPLOSION HAZARD

Do not disconnect solar power from the battery or any other power connections within the ControlWave Corrector enclosure or any power connections to optional items such as radio/modem, or cabling to the display/keypad unless the area is known to be nonhazardous.

 **WARNING** EXPLOSION HAZARD

Substitution of components may impair suitability for use in Class I, Division 2 environments.

 **WARNING** EXPLOSION HAZARD

The area must be known to be nonhazardous before servicing/replacing the unit and before installing or removing I/O wiring.

 **WARNING** EXPLOSION HAZARD

Do NOT disconnect equipment unless power has been disconnected and the area is known to be non-hazardous.

Table A-1. Module/Board Customer Wiring Connectors

Module/Item	Connector	Wiring Notes
CPU/System Controller board	TB1: 6-pin terminal block	Solar power: User wired * Primary power: Factory/User wired * Auxiliary output: Factory/User wired *
CPU/System Controller board	TB3: COM2, 8-pin terminal block RS-232	Remote comm. port: For radio or external network comm. Refer to model spec. and item 6 of this document. When used for network comm. use Div 2 wiring methods. If COM2 is used in conjunction with a radio/modem refer to item 7 of this document.*
CPU/System Controller board	TB4: COM3, 5-pin terminal block RS-232/RS-485	RS-232/485 comm. port: For external network comm. Refer to model spec. and item 6 of this document.*
CPU/System Controller board	TB5: 4-pin terminal block	Pulse input field wiring: Factory/User

Module/Item	Connector	Wiring Notes
	pulse input interface	wired. When connected to factory-installed TeleCounter (Pulser) it is nonincendive. When connected to user field I/O, this wiring connector is unrated, use Div. 2 wiring methods. *
CPU/System Controller board	TB6: 3-pin terminal block RTD interface	Field wired: Refer to item 5 of this document.*
CPU/System Controller board	J1: 8-pin RJ-45 jack 10/100Base-T Ethernet port	10/100Base-T Ethernet port jack for external connection to an Ethernet hub. Refer to model spec. and item 6 of this document.
CPU/System Controller board	J2: 8-pin RJ-45 female connector – display or display/keypad interface	Factory wired *
CPU/System Controller board	P1: MVT interface	Factory wired *
CPU/System Controller board	J4: COM1, 9-pin male D-sub RS-232 J11: COM1, 3-pin RS-232	RS-232 Comm. Port connectors: For external network comm. Refer to model spec. and item 6 of this document.
Process I/O board	TB2: 6-pin terminal block DI interface	Discrete input field wiring: Field I/O wiring connector is unrated, use Div. 2 wiring methods. *
Process I/O board	TB3: 8-pin terminal block DO/DI interface	Discrete output/input field wiring: Field I/O wiring connector is unrated, use Div. 2 wiring methods. *
Process I/O board	TB4: 8-pin terminal block HSC interface	High speed counter field wiring: Field input wiring connector is unrated, use Div. 2 wiring methods. *
Process I/O board	TB6: 9-pin terminal block AI interface	Analog input field wiring: Field input wiring connector is unrated, use Div. 2 wiring methods. *
Process I/O board	TB7: 4-pin terminal block AO interface	Analog output field wiring: Field output wiring connector is unrated, use Div. 2 wiring methods. *
Front cover bottom	Local Port 5-pin female circular connector (Present version)	Local comm.. port – factory wired. Refer to item 3 of this document. *

Note: * These wires should only be installed/removed when the item (PCB) in question is installed / removed or when checking wiring continuity. The area must be known to be nonhazardous before servicing / replacing the unit and before installing or removing PCBs, connectors, or individual I/O or power wires. Refer to the warnings in this document. All input power and I/O wiring must be performed in accordance with Class I, Division 2 wiring methods as defined in *Article 501-4(b)* of the *National Electrical Code, NFPA 70*, for installations within the United States, or as specified in *Section 18-152* of the *Canadian Electrical Code* for installation in Canada.

This page is intentionally left blank

Appendix Z – Sources for Obtaining Material Safety Data Sheets

This device includes certain components or materials which may be hazardous if misused. For details on these hazards, please contact the manufacturer for the *most recent* material safety data sheet.

Manufacturer	General Description	Emerson Part Number
DURACELL http://www.duracell.com	3V lithium manganese dioxide battery P/N: DL 2450	395620-01-5
TADIRAN http://www.tadiranbat.com	7.2 Vdc battery pack (each pack composed of two 3.6V , 35AH batteries) Individual battery P/N: TL-5137	395413-01-0
POWER SONIC http://www.power-sonic.com	6V, 7AH lead acid battery – Used with 1W, 6V solar panel or 5W, 6V solar panel P/N: PS-670	395407-01-0
POWER SONIC http://www.power-sonic.com	12V, 7AH lead acid battery – Used with 5W, 12V solar panel P/N: PS-1270	395407-02-8
DOW CORNING http://www1.dowcorning.com	Silicone 200(R) Fluid, 100 CST Pressure transducer media fill	

This page is intentionally left blank

Index

A

ACCOL3 Firmware Library	1-7
address	
default IP	4-2
Analog averaging	1-9
Analog Inputs	3-8
Analog Output	3-9

B

Backup battery	
description	1-4
disconnecting	5-9
jumper W3	2-21
removing/replacing	5-8
Backups	4-4
Battery	
replacing	5-8
Boot FLASH memory	
amount	1-4

C

Cables	
RS-232	2-27
RS-485	2-30
Shielding	3-4
Checking	
LEDs	5-12
Chromatograph	1-12
Class I, Division 2	2-3, A-1
Communication problems	
common reasons for	5-11
Communication Ports	
defaults	4-2
Ethernet	2-33
RS-232	2-25
RS-485	2-31
Communications	
Loop-back Test	5-16, 5-17
protocols supported	1-7
ControlWave project	
downloading	4-3
Core Updump	5-18
CPU/System Controller board	
battery backup	5-8
description	1-3
Jumpers	2-21
removing	5-6
switches	2-19

D

Defaults	
----------	--

Comm Ports	4-2
Diagnostic software	5-14
Disconnecting RAM Battery	5-9
Discrete Inputs	3-6
Discrete Outputs	3-7
Display/Keypad	2-38
Downloading	
the ControlWave project	4-3

E

Energy calculation	1-10
Energy integration	1-10
Environmental specifications	2-3
Ethernet Port	2-33
Extension calculation	1-9

F

Features	1-1
Field repair	5-6
Figures	
1-1. ControlWave Programming Environment	1-6
2-1. ControlWave Corrector Component	
Identification Diagram	2-2
2-2. ControlWave Corrector Mounted to Turbine	
Meter	2-7
2-3. ControlWave Corrector Meter Interface	
Mounting Hole Pattern	2-7
2-4. ControlWave Corrector Bottom View	2-8
2-5. Side View of ControlWave Corrector with	
TeleCounter	2-9
2-6. Side View of ControlWave Corrector	
(without TeleCounter)	2-10
2-7. TeleCounter Assembly (1 to 1 Gear Ratio)	
Rotation Adjust Diagram	2-11
2-8. TeleCounter Assembly (2 to 1 Gear Ratio)	
Rotation Adjust Diagram	2-12
2-9. ControlWave Corrector (with TeleCounter &	
GPT) Dimensions	2-15
2-10. ControlWave Corrector (without	
TeleCounter) Dimensions	2-16
2-11. CPU System Controller Board Component	
I.D. Diagram	2-18
2-12. CPU System Controller Board (TB1 &	
TB2) Power Wiring	2-25
2-13. PC Connected to ControlWave Corrector	
via Circular Local Port	2-26
2-14. Male DB9 9-Pin Connector	2-27
2-15. Full-duplex and Half-duplex Cable	2-28
2-16. Full-duplex and Half-duplex Cable	2-29
2-17. Connection from a Case Mounted Modem	
Radio to COM2 of the ControlWave Corrector	
.....	2-29
2-18. Full-duplex and Half-duplex Cable	2-29

2-19. RJ-45 Ethernet Connector	2-33	High Speed Counter/Discrete Inputs	3-13
2-20. Standard 10 100Base-T Ethernet Cable (CPU Module to Hub).....	2-33	Historical data storage	1-10
2-21. Point-to-Point 10 100Base T Ethernet Cable	2-34	Humidity specifications	2-3
2-22. 1 Watt Solar Panel Mounting Diagram	2-36	HyperTerminal	5-3
2-23. 5 Watt Solar Panel Mounting Diagram	2-37	I	
2-24. Optional 2-Button and 25-Button Keypads	2-38	I/O Wiring	3-4
2-25. Display with No Keypad	2-38	I/O Configurator	1-6
3-1. Process I/O Board Component Identification diagram	3-3	I/O Options.....	1-5
3-2. Process I/O Board Wiring diagrams.....	3-5	I/O Wiring.....	3-1
3-3. Pulse Input Wiring diagram.....	3-10	Installation.....	3-4
3-4. TeleCounter Wiring diagram	3-11	Class 1, Div 2	2-3
3-5. ISProx Wiring diagram	3-11	Overview.....	2-4
3-6. 3-Wire RTD Temperature Input Wiring .	3-14	IP address default.....	4-2
3-7. RTD Probe Installation Removal diagram	3-15	J	
3-8. 3808 Transmitter to ControlWave Corrector RS-232 Comm. Cable Diagram	3-16	Jumpers CPU/System Controller Board.....	2-21
3-9. 3808 Transmitter to ControlWave Corrector RS-485 Comm. Cable	3-17	Process I/O Board	3-2
3-10. ControlWave Corrector to 3808s - RS-485 Network Diagram	3-17	K	
4-1. Saving a Backup of Your Project	4-5	Keypad/Display	2-38
5-1. HyperTerminal Mode Menu	5-4	L	
5-2. HyperTerminal (Ready to Download).....	5-4	LEDs Checking.....	5-12
5-3. Send File dialog box.....	5-5	disabling	2-19
5-4. HyperTerminal (Download in progress) ..	5-5	LocalView.....	5-2
5-5. WINDIAG Main Diagnostics Menu.....	5-15	Loop-back Test	5-16, 5-17
5-6. COM1 & COM2 RS-232 Loop-back Plug/Wires	5-16	M	
5-7. COM3 RS-232 & RS-485 Loop-back Wires	5-16	Material Safety Data Sheets (MSDS) how to obtain	Z-1
5-8. Communications Diagnostic menu	5-17	Memory Boot FLASH.....	1-4
Firmware upgrade.....	5-2	FLASH amount.....	1-4
HyperTerminal.....	5-3	SRAM amount	1-5
LocalView	5-2	N	
System Firmware Downloader	5-2	Nominations	1-13
FLASH memory		O	
amount.....	1-4	Odorizer	1-12
Flow calculations		Operator's keypad/display	2-38
supported	1-8	P	
Flow rate calculations		Power connecting or disconnecting.....	4-2
AGA3.....	1-9	wiring	2-23
AGA7	1-9	Power connector TB1	2-24
Flow time calculations		Power connector TB2	2-25
AGA3.....	1-9		
AGA7	1-9		
G			
Grounding.....	2-17, 3-4		
H			
Hazardous locations			
special instructions for.....	A-1		

Power options	1-5	2-8. RS-232 Port Alternate Connector Pin Assignment.....	2-28
Process I/O board replacing	5-6	2-9. RS-485 Connector on CPU	2-30
Process I/O Board configurations	3-1	2-10. RS-485 Port Connector Pin Assignment. 2- 30	
Jumpers.....	3-2	2-11. RS-485 Network Connections.....	2-31
switches.....	3-2	2-12. Ethernet 10/100Base-T CPU Module Pin Assignments.....	2-33
Process I/O board Configurations	1-5	2-13. Solar Panel Tilt Angle.....	2-35
Protocols supported in ControlWave.....	1-7	3-1. Process I/O Configurations	3-1
Pulse Counter/Discrete Inputs.....	3-10	3-2. Process I/O Module Switch SW1	3-2
R		3-3. Non-Isolated DI General Characteristics. 3-6	
RAM Battery Disconnecting.....	5-9	3-4. Non-Isolated DO General Characteristics.3-7	
Recovery mode switches.....	2-19	3-5. Non-Isolated AI General Characteristics. 3-8	
Repair in field	5-6	3-6. Non-Isolated AO General Characteristics.3-9	
Resistance Temperature Device (RTD)	3-14	3-7. Non-Isolated Pulse Counter Discrete Inputs General Characteristics.....	3-10
RS-232 Ports	2-25	3-8. Non-Isolated High Speed Counter/Discrete Inputs General Characteristics.....	3-13
Cables	2-27	3-9. RTD Connections to CPU System Controller Board Connector TB6.....	3-14
RS-485 Ports	2-31	4-1. Default Comm Port Settings (by PCB)	4-2
Cables	2-30	5-1. LEDs on CPU System Controller Board board	5-12
configuration switch.....	2-20	5-2. LCD Display Status Codes.....	5-12
Run switching	1-12	A-1. Module/Board Customer Wiring Connectors	A-2
Running diagnostic software.....	5-14	TB1 Connector.....	2-24
S		TB2 Connector.....	2-25
Sampler.....	1-12	Temperature specifications	2-3
Site Considerations.....	2-1	Tools	5-1
Soft Switches lock/unlock switch.....	2-19	Transmitters connecting	3-16
use/ignore switch.....	2-19	Troubleshooting	5-1
Software Tools.....	1-6	common communication config problems	5-11
Specifications for temperature, humidity, vibration.....	2-3	U	
SRAM memory amount.....	1-5	Updump	5-18
control switch.....	2-20	switch.....	2-20
Status codes	5-12	Upgrading firmware.....	5-2
Switches CPU	2-19	V	
Process I/O board	3-2	Vibration specifications	2-3
System Firmware Downloader.....	5-2	Volume calculations supported.....	1-8
T		Volume integration.....	1-10
Tables		W	
1-1. CPU/System Controller board Variations	1-4	W3 Backup battery jumper	2-21
1-2.Process I/O Configurations	1-5	Watchdog enable switch.....	2-19
2-1. Flow Meter Mounting Position.....	2-6	WINDIAG	5-14
2-2. CPU System Controller Board Switch SW1	2-19	Wiring I/O	3-1, 3-4
2-3. CPU/System Controller Board Switch SW2	2-19		
2-4. RS-485 Configuration Switch (SW3)....	2-20		
2-5. Power Requirements.....	2-23		
2-6. RS-232 Connectors on CPU	2-26		
2-7. RS-232 Port Connector Pin Assignment	2-27		

Headquarters:

Emerson Process Management
Remote Automation Solutions
6005 Rogerdale Road
Houston, TX 77072 U.S.A.
T +1 281 879 2699 | F +1 281 988 4445
www.EmersonProcess.com/Remote

Europe:

Emerson Process Management
Remote Automation Solutions
Unit 8, Waterfront Business Park
Dudley Road, Brierly Hill
Dudley UK DY5 1LX
T +44 1384 487200 | F +44 1384 487258
www.EmersonProcess.com/Remote

North American/Latin America:

Emerson Process Management
Remote Automation Solutions
6005 Rogerdale Road
Houston TX USA 77072
T +1 281 879 2699 | F +1 281 988 4445
www.EmersonProcess.com/Remote

Middle East/Africa:

Emerson Process Management
Remote Automation Solutions
Emerson FZE
P.O. Box 17033
Jebel Ali Free Zone – South 2
Dubai U.A.E.
T +971 4 8118100 | F +971 4 8865465
www.EmersonProcess.com/Remote

Asia-Pacific:

Emerson Process Management
Remote Automation Solutions
1 Pandan Crescent
Singapore 128461
T +65 6777 8211 | F +65 6777 0947
www.EmersonProcess.com/Remote

© 2013 Remote Automation Solutions, a business unit of Emerson Process Management. All rights reserved.

Remote Automation Solutions, a business unit of Emerson Process Management, shall not be liable for technical or editorial errors in this manual or omissions from this manual. REMOTE AUTOMATION SOLUTIONS MAKES NO WARRANTIES, EXPRESSED OR IMPLIED, INCLUDING THE IMPLIED WARRANTIES OF MERCHANTABILITY AND FITNESS FOR A PARTICULAR PURPOSE WITH RESPECT TO THIS MANUAL AND, IN NO EVENT SHALL REMOTE AUTOMATION SOLUTIONS BE LIABLE FOR ANY INCIDENTAL, PUNITIVE, SPECIAL OR CONSEQUENTIAL DAMAGES INCLUDING, BUT NOT LIMITED TO, LOSS OF PRODUCTION, LOSS OF PROFITS, LOSS OF REVENUE OR USE AND COSTS INCURRED INCLUDING WITHOUT LIMITATION FOR CAPITAL, FUEL AND POWER, AND CLAIMS OF THIRD PARTIES.

Bristol, Inc., Bristol Canada, BBI SA de CV and Emerson Process Management Ltd, Remote Automation Solutions (UK), are wholly owned subsidiaries of Emerson Electric Co. doing business as Remote Automation Solutions, a business unit of Emerson Process Management. FloBoss, ROCLINK, Bristol, Bristol Babcock, ControlWave, TeleFlow, Helicoid, OpenEnterprise, and METCO are trademarks of Remote Automation Solutions. AMS, PlantWeb and the PlantWeb logo are marks of Emerson Electric Co. The Emerson logo is a trademark and service mark of the Emerson Electric Co. All other marks are property of their respective owners.

The contents of this publication are presented for informational purposes only. While every effort has been made to ensure informational accuracy, they are not to be construed as warranties or guarantees, express or implied, regarding the products or services described herein or their use or applicability. Remote Automation Solutions reserves the right to modify or improve the designs or specifications of such products at any time without notice. All sales are governed by Remote Automation Solutions' terms and conditions which are available upon request. Remote Automation Solutions does not assume responsibility for the selection, use or maintenance of any product. Responsibility for proper selection, use and maintenance of any Remote Automation Solutions product remains solely with the purchaser and end-user.