

ControlWave® I/O Expansion Rack



IMPORTANT! READ INSTRUCTIONS BEFORE STARTING!

Be sure that these instructions are carefully read and understood before any operation is attempted. Improper use of this device in some applications may result in damage or injury. The user is urged to keep this book filed in a convenient location for future reference.

These instructions may not cover all details or variations in equipment or cover every possible situation to be met in connection with installation, operation or maintenance. Should problems arise that are not covered sufficiently in the text, the purchaser is advised to contact Emerson Process Management, Remote Automation Solutions for further information.

EQUIPMENT APPLICATION WARNING

The customer should note that a failure of this instrument or system, for whatever reason, may leave an operating process without protection. Depending upon the application, this could result in possible damage to property or injury to persons. It is suggested that the purchaser review the need for additional backup equipment or provide alternate means of protection such as alarm devices, output limiting, fail-safe valves, relief valves, emergency shutoffs, emergency switches, etc. If additional information is required, the purchaser is advised to contact Remote Automation Solutions.

RETURNED EQUIPMENT WARNING

When returning any equipment to Remote Automation Solutions for repairs or evaluation, please note the following: The party sending such materials is responsible to ensure that the materials returned to Remote Automation Solutions are clean to safe levels, as such levels are defined and/or determined by applicable federal, state and/or local law regulations or codes. Such party agrees to indemnify Remote Automation Solutions and save Remote Automation Solutions harmless from any liability or damage which Remote Automation Solutions may incur or suffer due to such party's failure to so act.

ELECTRICAL GROUNDING

Metal enclosures and exposed metal parts of electrical instruments must be grounded in accordance with OSHA rules and regulations pertaining to "Design Safety Standards for Electrical Systems," 29 CFR, Part 1910, Subpart S, dated: April 16, 1981 (OSHA rulings are in agreement with the National Electrical Code).

The grounding requirement is also applicable to mechanical or pneumatic instruments that include electrically operated devices such as lights, switches, relays, alarms, or chart drives.

EQUIPMENT DAMAGE FROM ELECTROSTATIC DISCHARGE VOLTAGE

This product contains sensitive electronic components that can be damaged by exposure to an electrostatic discharge (ESD) voltage. Depending on the magnitude and duration of the ESD, this can result in erratic operation or complete failure of the equipment. Read supplemental document S14006 for proper care and handling of ESD-sensitive components.

Contents

Chapter 1 – Introduction 1-1

1.1	Scope of the Manual	1-2
1.2	Physical Description	1-2
1.3	Housings	1-3
1.4	CPU Module	1-5
1.5	Power Supply/Sequencer Module (PSSM)	1-6
1.6	I/O Modules	1-6
1.7	Secure Gateway	1-7

Chapter 2 – Installation 2-1

2.1	Site Considerations	2-1
2.1.1	Class I, Div 2 Installation Considerations	2-2
2.2	Installation Overview	2-3
2.2.1	Unpacking Components	2-4
2.2.2	Color Coding of Slot Connectors	2-5
2.2.3	Mounting the Housing	2-7
2.2.4	Grounding the Housing	2-11
2.3	Power Supply/Sequencer Module (PSSM)	2-11
2.3.1	General Information about the PSSM	2-11
2.3.2	PSSM Installation Overview	2-13
2.3.3	Setting Jumpers	2-14
2.3.4	General Wiring Guidelines	2-16
2.3.5	Wiring a Bulk DC Power Supply to the PSSM	2-17
2.3.6	Hot-swapping a Power Supply	2-20
2.3.7	Wiring an External Alarm or Annunciator to the Watchdog Connector and Wiring the Redundancy Control Input (OPTIONAL)	2-21
2.3.8	Wiring Digital Inputs to indicate Power Supply Failure	2-23
2.3.9	PSSM Specifications	2-24
2.4	CPU Module	2-25
2.4.1	Setting DIP Switches on the CPU Module	2-26
2.4.2	Connections to RS-232 Serial Port(s)	2-29
2.4.3	Connections to RS-485 Serial Port on the Secondary Communication Board (SCB)	2-32
2.4.4	Connections to Ethernet Port(s) on the CPU Module	2-34
2.5	Bezels	2-35

Chapter 3 – I/O Modules 3-1

3.1	Module Placement	3-3
3.2	Status LEDs	3-4
3.3	Wiring	3-4
3.3.1	Local Termination	3-5
3.3.2	Remote Termination	3-6
3.3.3	Shielding and Grounding	3-6
3.4	Digital Input (DI) Modules	3-8
3.5	Digital Output (DO) Modules	3-13
3.6	Analog Input (AI) Modules	3-20
3.7	Analog Output (AO) Modules	3-25
3.8	Universal Digital Input (UDI) Modules	3-30
3.9	Isolated Resistance Temperature Device (RTD) Input Module	3-36
3.10	Isolated Thermocouple Module	3-40

Chapter 4 – Operation **4-1**

- 4.1 Powering Up/Powering Down the ControlWave I/O Expansion Rack 4-1
- 4.2 Communicating with the ControlWave I/O Expansion Rack..... 4-1
 - 4.2.1 Default Comm Port Settings 4-1
 - 4.2.2 Changing Port Settings 4-2

Chapter 5 – Service and Troubleshooting **5-1**

- 5.1 Upgrading Firmware..... 5-2
- 5.2 Removing or Replacing Components 5-5
 - 5.2.1 Accessing Modules for Testing 5-5
 - 5.2.2 Removing/Replacing the Bezel 5-5
 - 5.2.3 Removing/Replacing the CPU Module 5-6
 - 5.2.4 Removing/Replacing the PSSM..... 5-6
 - 5.2.5 Removing/Replacing an I/O Module (Hot Swapping) 5-7
 - 5.2.6 Removing/Replacing the Backup Battery 5-12
- 5.3 General Troubleshooting Procedures 5-13
 - 5.3.1 Common Communication Configuration Problems..... 5-13
 - 5.3.2 Checking LEDs 5-14
 - 5.3.3 Checking Wiring/Signals 5-22
 - 5.3.4 Port 80 Display Codes 5-22
 - 5.3.5 Reset Switch 5-26
- 5.4 WINDIAG Diagnostic Utility..... 5-26
 - 5.4.1 Available Diagnostics 5-28
- 5.5 Core Updump..... 5-32

Appendix A – Special Instructions for Class I, Division 2 Hazardous Locations. **A-1**

Appendix B – Open MODBUS Interface **B-1**

Appendix Z – Sources for Obtaining Material Safety Data Sheets **Z-1**

Index **IND-1**

Chapter 1 – Introduction

The ControlWave I/O Expansion Rack provides additional I/O in a separately mounted rack for an existing ControlWave process automation controller.

This manual focuses on the hardware aspects of the ControlWave® I/O Expansion Rack. For information about the software used with the ControlWave I/O Expansion Rack, refer to the *ControlWave I/O Expansion Rack Quick Setup Guide* (D5122), the *ControlWave Designer Programmer's Handbook* (D5125), and the online help in ControlWave Designer.

This chapter details the structure of this manual and provides an overview of the I/O rack and its components.

In This Chapter

1.1	Scope of the Manual.....	1-2
1.2	Physical Description	1-2
1.3	Housings	1-3
1.4	CPU Module	1-5
1.5	Power Supply/Sequencer Module (PSSM)	1-6
1.6	I/O Modules.....	1-6
1.7	Secure Gateway	1-7

The ControlWave I/O expansion rack was designed with an emphasis on providing high performance with low power consumption, scalability, and modularity.

You can configure the ControlWave I/O expansion rack as a slave to a ControlWave Process Automation Controller (CWPAC), ControlWave Redundant Controller (CWRED), or a ControlWave Redundant I/O Switch Unit (CWRED I/O). Communication to the rack can be via an Ethernet connection, serial MODBUS, or Open MODBUS.

Features ControlWave I/O expansion racks have the following key features:

- Low power consumption
- Small size (enabling panel mount or 19 inch rack-mount installations)
- Two or three RS-232 ports
- One or three 10/100 MB Ethernet ports
- Options for additional communication ports
- Housings to support four or eight I/O modules
- Variety of I/O modules and support for hot swapping of I/O modules
- Support for redundant operation with another ControlWave I/O expansion rack
- LED status indicators on the CPU, PSSM, and certain I/O modules

- Port 80 display to present status codes
- Battery backup for the real-time clock and the system's static RAM (SRAM)
- Class I, Division 2 Hazardous Location approvals (Requires an appropriate enclosure that meets NEMA Type 3X or 4X specifications.)

1.1 Scope of the Manual

This manual contains the following chapters:

Chapter 1 Introduction	Provides an overview of the hardware and general specifications for the ControlWave.
Chapter 2 Installation	Provides information on the housings, the Power Supply/Sequencer module (PSSM), and the CPU module.
Chapter 3 I/O Modules	Provides general information and wiring diagrams for the I/O modules.
Chapter 4 Operation	Provides information on day-to-day operation of the I/O rack.
Chapter 5 Service and Troubleshooting	Provides information on service and troubleshooting procedures.

1.2 Physical Description

Each ControlWave has a printed circuit board (PCB) backplane mounted in a stainless steel housing, a Power Supply/Sequencer Module (PSSM), a CPU module which may include an optional Secondary Communication Board (SCB) and—depending on the backplane and housing size—up to eight I/O modules.

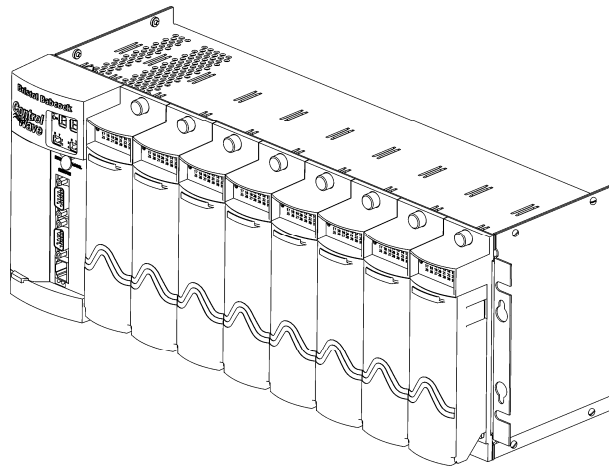

Figure 1-1. ControlWave I/O Expansion Rack with 8 I/O Modules

Refer to the following sections in this chapter or to other chapters in this manual for further information:

- Housings (chassis) with backplanes (see *Section 1.3* and *Chapter 2*)

- Power Supply/Sequencer module (PSSM) (see *Section 1.5* and *Chapter 2*)
- CPU module (see *Section 1.4* and *Chapter 2*)
- One or more I/O modules (see *Section 1.6* and *Chapter 3*)

1.3 Housings

ControlWave housings are stainless steel designed for panel/wall-mounting or for some versions, for mounting in a 19-inch equipment rack. They contain the printed circuit board (PCB) backplane into which you connect the PSSM, the CPU module, and any I/O modules.

The following housings are available:

- 6-slot backplane supports one PSSM, one CPU, and up to four I/O modules.
- 10-slot housing supports one PSSM, one CPU, and up to eight I/O modules. The 10-slot housing is suitable for mounting in a 19-inch equipment rack.

Hot swap detection circuitry within the PSSM allows for the safe insertion and removal of I/O modules while power is on.

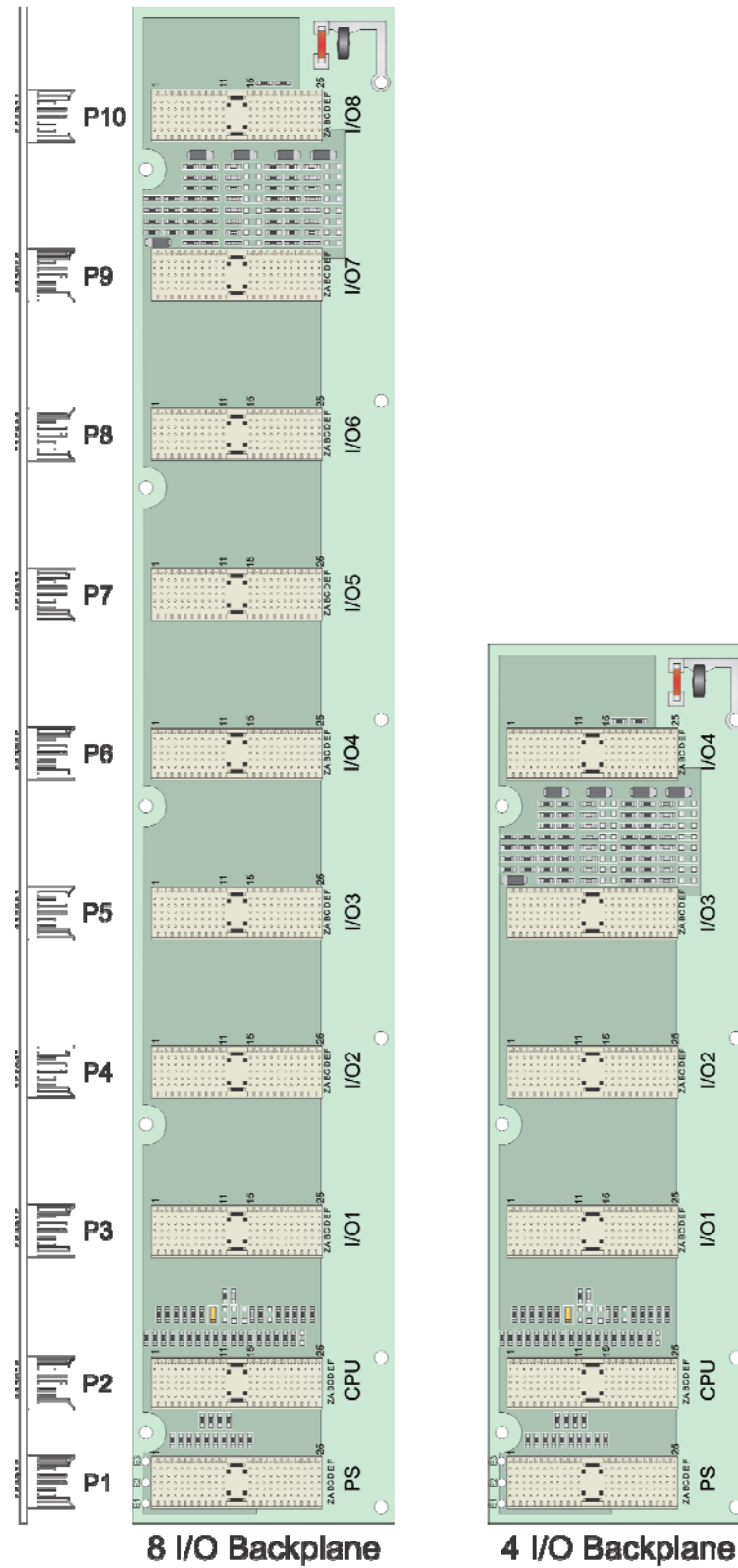

Figure 1-2. ControlWave I/O Expansion Rack Housing Options

1.4 CPU Module

Note: The ControlWave I/O Expansion Rack CPU **does** not accept a downloadable ControlWave project (software application), it only holds I/O modules. A separate ControlWave Process Automation Controller runs the ControlWave project which must reference the I/O points in the ControlWave I/O Expansion Rack.

The CPU (central processing unit) module houses the CPU board, and if present the secondary communications board (SCB). The CPU module provides I/O monitor/control, memory, and communication functions.

The CPU board includes:

- Intel 386EX microprocessor running at 25 MHz
- 2 RS-232 communication ports
- 1 10/100baseT Ethernet port
- 2 MB of battery backed Static RAM (SRAM)
- 512 KB boot/downloader FLASH
- 32 MB simultaneous read/write FLASH memory
- configuration DIP switches (described in *Chapter 2*)
- Port 80 display to show status codes

You can order the CPU module with the optional secondary communication board (SCB) for additional communication ports. See *CPU Module Configurations*.

CPU Module Configurations The CPU module has two basic configurations, all of which have an on-board backup battery and different combinations of communications ports.

Table 1-1. CPU Module Configurations

Number of RS-232 Ports	Number of RS-485 Ports	Number of Ethernet Ports	Notes
2 (COM1 & COM2)	0	1 (ETH1)	No SCB.
3 (COM1, COM2, COM4)	1 (COM3)	3 (ETH1, ETH2, ETH3)	For this port count, 1 RS-232 (COM4), 1 RS-485 (COM3), and 2 Ethernet ports (ETH2, ETH3) reside on the SCB.

CPU Backup Battery The CPU module includes a 3.6V, 950 mA-hr lithium ½ AA battery. This battery provides backup power for the real-time clock and the system's Static RAM (SRAM).

CPU Memory There are several different types of memory used on the CPU module:

Boot/Downloader FLASH

Boot/download code is contained in a single 512 Kbyte FLASH chip. Boot FLASH also holds the value of soft switches, audit/archive file configurations, and user account and port information.

FLASH Memory

The CPU module contains 32 MB of FLASH memory. The FLASH memory holds the system firmware. The FLASH does not support hardware write protection.

System Memory (SRAM)

The CPU module has 2 MB of static random access memory (SRAM). During power loss periods, SRAM enters data retention mode (powered by the CPU backup battery). Critical system information that must be retained during power outages or when the system has been disabled for maintenance is stored here. This includes the last states of all I/O points.

1.5 Power Supply/Sequencer Module (PSSM)

The Power Supply/Sequencer module (PSSM) takes power from an external bulk DC power supply and then provides power through the ControlWave housing/backplane to all installed modules.

The PSSM operates from +22.2 to +30V (dc) and ships from the factory with a nominal input supply configuration of 24V.

The PSSM includes:

- ON/OFF system power switch(es) for each power supply board
- Pluggable terminal block to connect the external power supply
- Watchdog output connector to signal a watchdog failure to an external device
- Status LEDs

Chapter 2 includes instructions for installing and configuring the PSSM.

1.6 I/O Modules

The ControlWave I/O expansion rack supports analog input, analog output, digital input, digital output, universal digital input, isolated RTD, and isolated low level analog (thermocouple and mv) input modules for either local or remote field device wiring termination.

Refer to *Chapter 3* for information on specific I/O modules. *Figure 1-3* shows a typical I/O module housing.

Terminations are pluggable and accept a maximum wire size of #14 AWG. Each I/O module connects to the backplane using a 110-pin male connector and to its associated terminal block assembly using a 44 pin header.

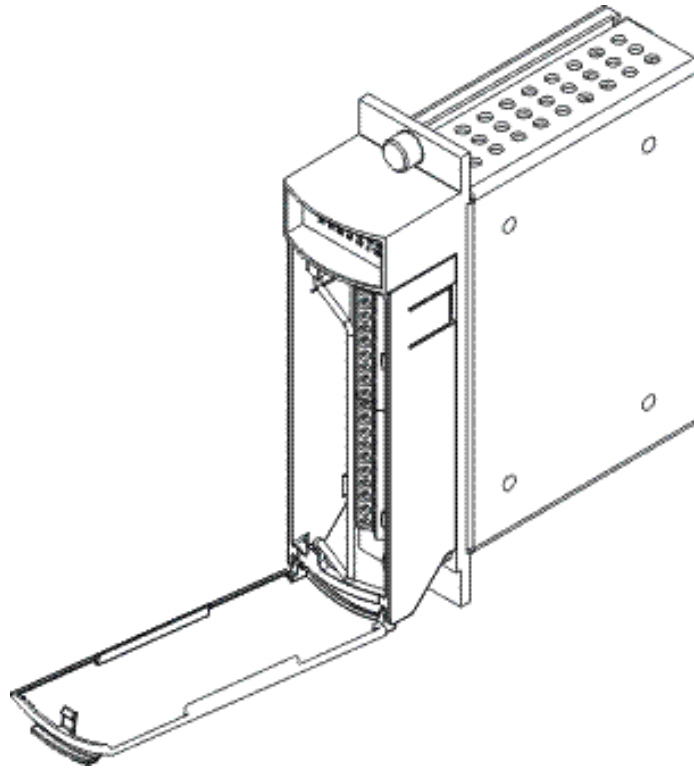

Figure 1-3. I/O Module (with door open)

1.7 Secure Gateway

For enhanced data security when using an IP/Ethernet connection, Emerson Remote Automation Solutions recommends adding an industrial router with VPN and firewall security. Recommended solutions include the MOXA EDR-810, the Hirschman Eagle One, or the Phoenix mGuard rs4000 (or equivalents). An example of how to install one of these devices to the RTU can be found in the Emerson Remote Automation Solutions *MOXA® Industrial Secure Router Installation Guide* (part number D301766X012). For further information, contact your Local Business Partner or the individual vendor's website.

This page is intentionally left blank

Chapter 2 – Installation

This chapter discusses the physical configuration of the ControlWave I/O Expansion Rack, considerations for installation, wiring instructions for the PSSM module, and instructions for setting switches and jumpers on the CPU module. For instructions on I/O installation, see *Chapter 3*.

In This Chapter

2.1	Site Considerations.....	2-1
2.1.1	Class I, Div 2 Installation Considerations.....	2-2
2.2	Installation Overview.....	2-3
2.2.1	Unpacking Components.....	2-4
2.2.2	Color Coding of Slot Connectors.....	2-5
2.2.3	Mounting the Housing	2-7
2.2.4	Grounding the Housing	2-11
2.3	Power Supply/Sequencer Module (PSSM)	2-11
2.3.1	General Information about the PSSM	2-11
2.3.2	PSSM Installation Overview	2-13
2.3.3	Setting Jumpers	2-14
2.3.4	General Wiring Guidelines	2-16
2.3.5	Wiring a Bulk DC Power Supply to the PSSM	2-17
2.3.6	Hot-swapping a Power Supply.....	2-20
2.3.7	Wiring an External Alarm or Annunciator to the Watchdog Connector and Wiring the Redundancy Control Input (OPTIONAL)	2-21
2.3.8	Wiring Digital Inputs to indicate Power Supply Failure	2-23
2.3.9	PSSM Specifications	2-24
2.4	CPU Module	2-25
2.4.1	Setting DIP Switches on the CPU Module	2-26
2.4.2	Connections to RS-232 Serial Port(s).....	2-29
2.4.3	Connections to RS-485 Serial Port on the Secondary Communication Board (SCB).....	2-32
2.4.4	Connections to Ethernet Port(s) on the CPU Module	2-34
2.5	Bezels	2-35

2.1 Site Considerations

When choosing an installation site, check all clearances. Ensure that the ControlWave I/O expansion rack is accessible for wiring and service.



Caution

To ensure safe use of this product, please review and follow the instructions in the following supplemental documentation:

- **Supplement Guide - ControlWave Site Considerations for Equipment Installation, Grounding, and Wiring (S1400CW)**
- **ESDS Manual – Care and Handling of PC Boards and ESD Sensitive Components (S14006)**

**Specifications
for Temperature,
Humidity and
Vibration**

- See document CWPAC available on our website for detailed technical specifications for temperature, humidity, and vibration for the ControlWave I/O Expansion Rack. This document is available on our website at: <http://www.emersonprocess.com/remote>.
- Ensure that the ambient temperature and humidity at the installation site remains within these specifications. Operation beyond the specified ranges could cause output errors and erratic performance. Prolonged operation under extreme conditions could also result in failure of the unit.
- Check the mounted enclosure, panel, or equipment rack for mechanical vibrations. Make sure that the ControlWave is not exposed to a level of vibration that exceeds that provided in the technical specifications..

2.1.1 Class I, Div 2 Installation Considerations



Caution

Placement of the ControlWave in Class 1, Division 2 (Group A, B, C, and D) hazardous locations requires that you select an appropriate enclosure that meets NEMA Type 3X or 4X specifications.

Underwriters Laboratories (UL) lists the ControlWave I/O Expansion Rack as non-incendive and suitable **only** for use in Class I, Division 2, Group A, B, C, and D hazardous locations and non-hazardous locations. Read this chapter and *Appendix A* carefully before you install a ControlWave in a hazardous location.

Perform all power and I/O wiring in accordance with Class I, Division 2 wiring methods as defined in *Article 501-4 (b)* of the *National Electrical Code, NFPA 70* (for installations within the United States) or as specified in *Section 18-152* of the *Canadian Electrical Code* (for installation in Canada).



WARNING

EXPLOSION HAZARD

Substitution of components may impair suitability for use in Class I, Division 2 environments.

When the ControlWave I/O Expansion Rack is situated in a hazardous location, turn off power before servicing or replacing the unit and before installing or removing I/O wiring.

Do not connect or disconnect equipment unless the power is switched off or the area is known to be non-hazardous.

2.2 Installation Overview

Installing a ControlWave I/O Expansion Rack involves several general steps, and includes not just the I/O expansion rack(s), but configuration of its host ControlWave Process Automation Controller to reference the I/O in the I/O expansion rack.

1. Unpacking, assembling, and configuring the hardware.
 - a) Mount the housing (*Section 2.2.3*).
 - b) Install the PSSM in chassis slot 1 (*Section 2.3.1*).
 - c) Set CPU switches then install the CPU in chassis slot 2 (*Section 2.4.1*).
 - d) Make communication port connections, including a connection between your PC and the I/O rack (*Sections 2.4.2, 2.4.3 and 2.4.4*).
 - e) Install I/O modules in chassis slots 3 through 6 (or 3 through 10) and wire the I/O modules to I/O devices (*Chapter 3*).
 - f) Install a ground wire between the chassis ground lug and a known good earth ground (*Section 2.2.4*).
 - g) If required, install watchdog switch wiring and redundancy control wiring (*Section 2.3.7*).
 - h) Connect bulk DC power to the PSSM module. (*Section 2.3.5*)
 - i) Install the bezel to cover the PSSM and CPU. (*Section 2.5*)
 - j) Plug an Ethernet cable from you network to one of the Ethernet ports.
 - k) Open the bezel door and turn on the power on the PSSM module.
 - l) Check the display; when the power on sequence finishes, it should be blank.
2. Installing PC-based software (ControlWave Designer and OpenBSI).
3. Establishing communication by connecting the PC to one of the I/O rack's communication ports.
4. Setting flash memory parameters in the I/O expansion rack(s).
5. Creating an application-specific control strategy (ControlWave project) for the ControlWave host that references the I/O in the I/O expansion rack.
6. Downloading the application-specific ControlWave project into the ControlWave host controller.

Note: Steps 2 through 6 require that you install and use ControlWave Designer and OpenBSI software on your PC. This manual focuses on hardware installation and preparation. Software installation and configuration is beyond the scope of this manual. Refer to the *ControlWave I/O Expansion Rack Quick Setup Guide (D5122)* for material related to software configuration.

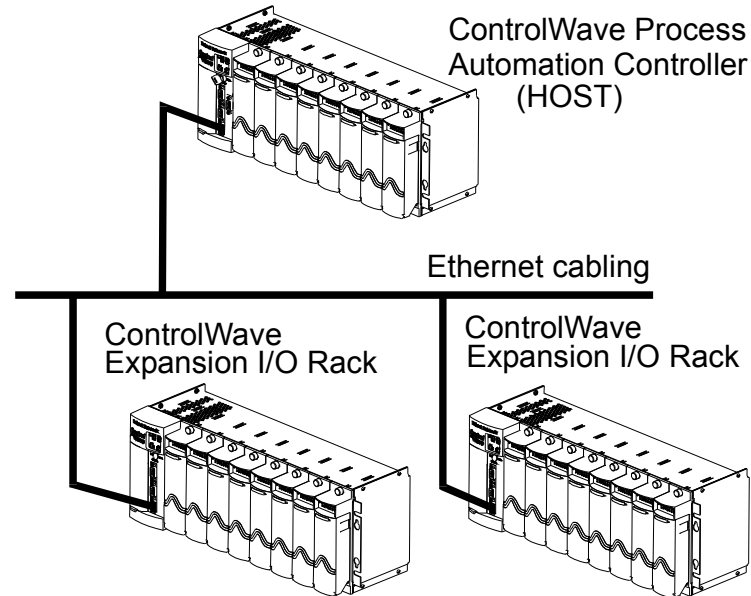

Figure 2-1. ControlWave Process Automation Controller (PAC) with Two I/O Expansion Racks

2.2.1 Unpacking Components

Packaging Depending upon how you order it, the ControlWave I/O Expansion Rack may arrive pre-assembled, with all modules installed in the housing, or as individual components in a number of separate boxes. In the latter case, you must identify, unpack, and assemble the components. Unless otherwise noted, you can place I/O modules in any slot in a base or expansion housing.

Note: Do **not** install modules in the housing until you have mounted and grounded the housing at the designated installation site.

Delivered boxes may include:

- Housing assemblies
- Power Supply/Sequencer module (PSSM)

Note: The PSSM must reside in slot #1 in the base housing.

- CPU module

Note: The CPU module must reside in slot #2 in the base housing.

- I/O Modules

Notes:

- There are many different types of I/O modules available. *Chapter 3* contains detailed instructions on each I/O module.
- Universal Digital Input (UDI) modules can only reside in the first four I/O slots. One or more bezel assemblies; each bezel covers two I/O modules.

2.2.2 Color Coding of Slot Connectors

A color tab on each backplane connector matches the color on the module which you can place in that slot.

- PSSM goes in the first slot (Yellow tab)
- CPU goes in the second slot (Blue tab)
- I/O modules go in any other slot (Green tab)

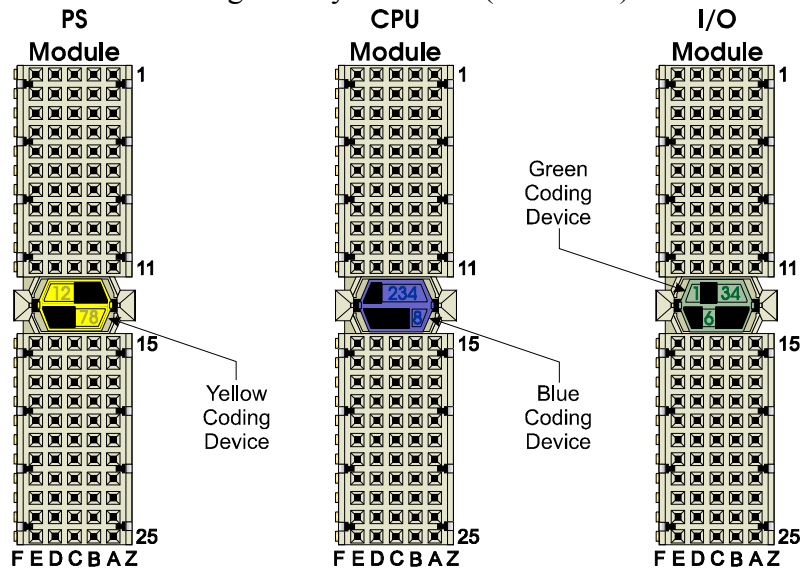

Figure 2-2. Color Coded Board Connectors

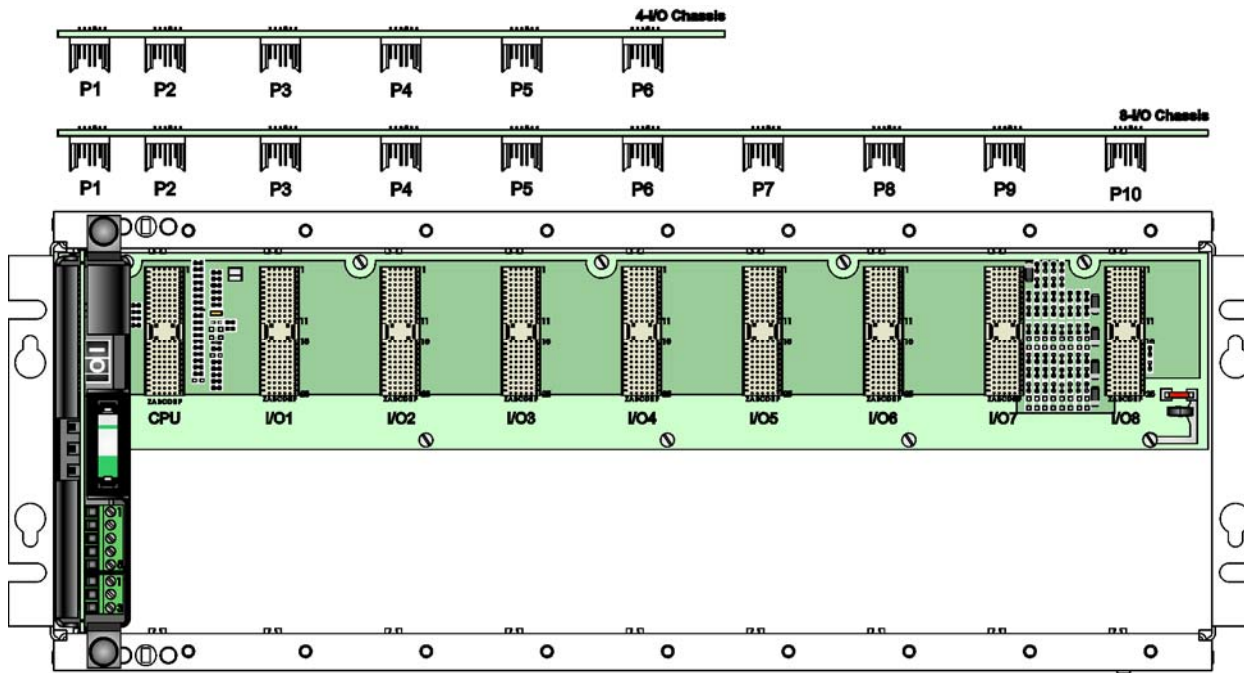

Figure 2-3. PSSM Installed in ControlWaveEXP Slot #1

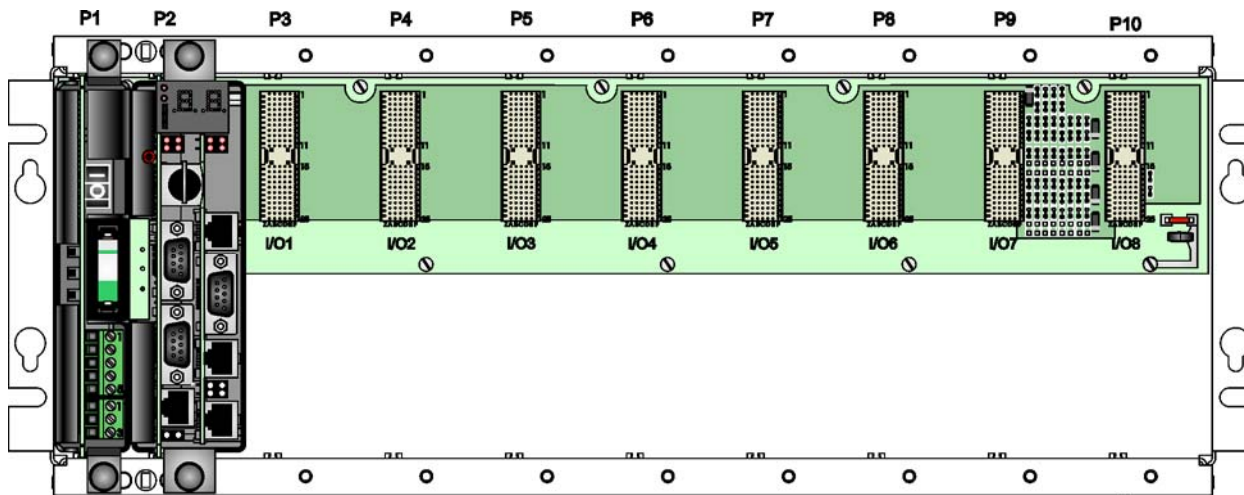

Figure 2-4. PSSM & CPU (with SCB) Installed in Slot #1 & #2 (Respectively)

2.2.3 Mounting the Housing

ControlWave I/O expansion rack modules reside in a stainless steel housing. No enclosure is provided.

You can install a ControlWave equipped with a 4-I/O module housing on a wall or panel. See *Figure 2-6* for mounting hole patterns for a 4-I/O unit.

You can install a ControlWave I/O expansion rack equipped with an 8-I/O module housing in a 19-inch equipment rack, a panel or a wall. These units ship from the factory with the end plates configured for 19-inch rack mounting. Remove the end plates, rotate them 180° and then reinstall them to accommodate panel or wall mounting. See *Figure 2-5* for hole patterns and dimensions.

When you install any of these units on a panel or wall, position it according to the following restrictions:

- Position the unit so that you can see the front of the assembly and so it is accessible for service such as installing a module or replacing a battery.
- Do not install ControlWave modules until you mount the chassis and ground it properly.

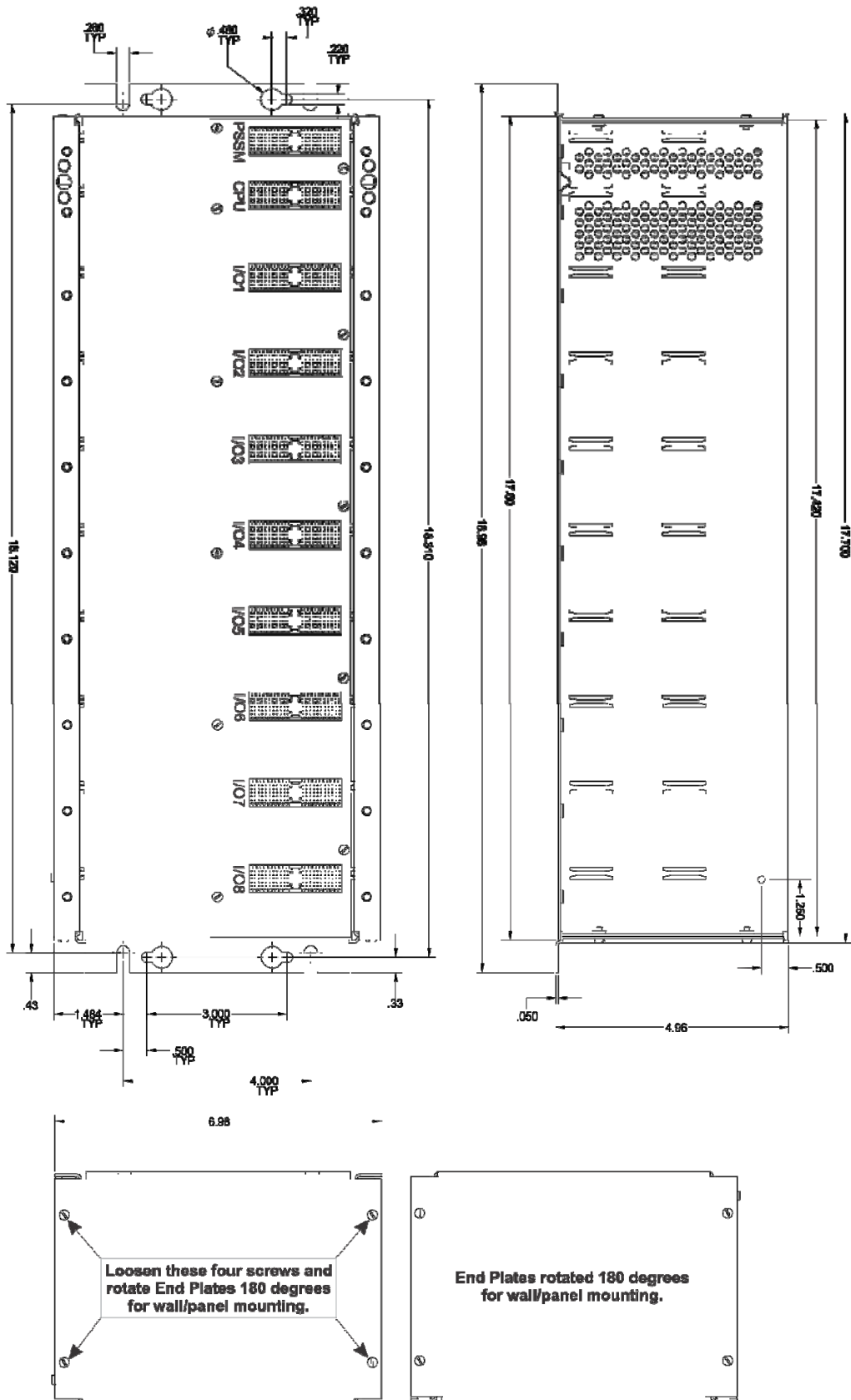

Figure 2-5. 8-I/O Module ControlWave I/O Rack - Mounting Diagram (dimensions in inches)

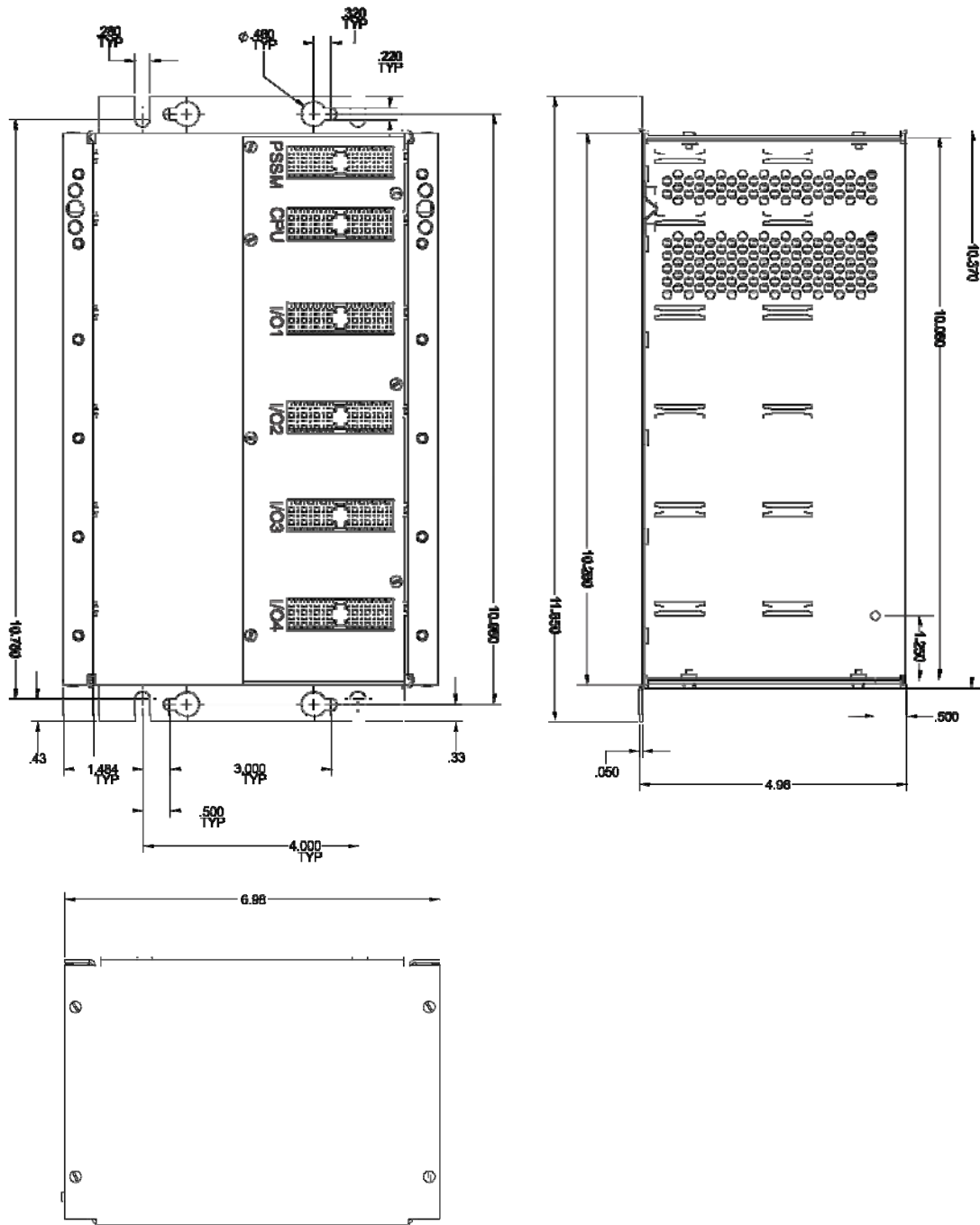
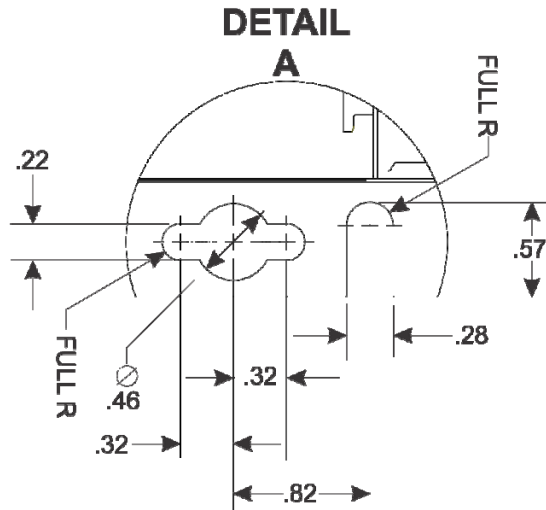
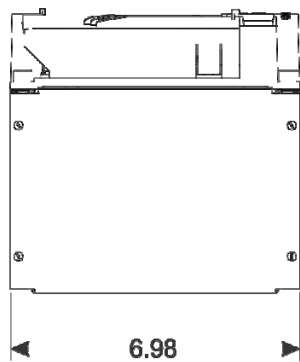
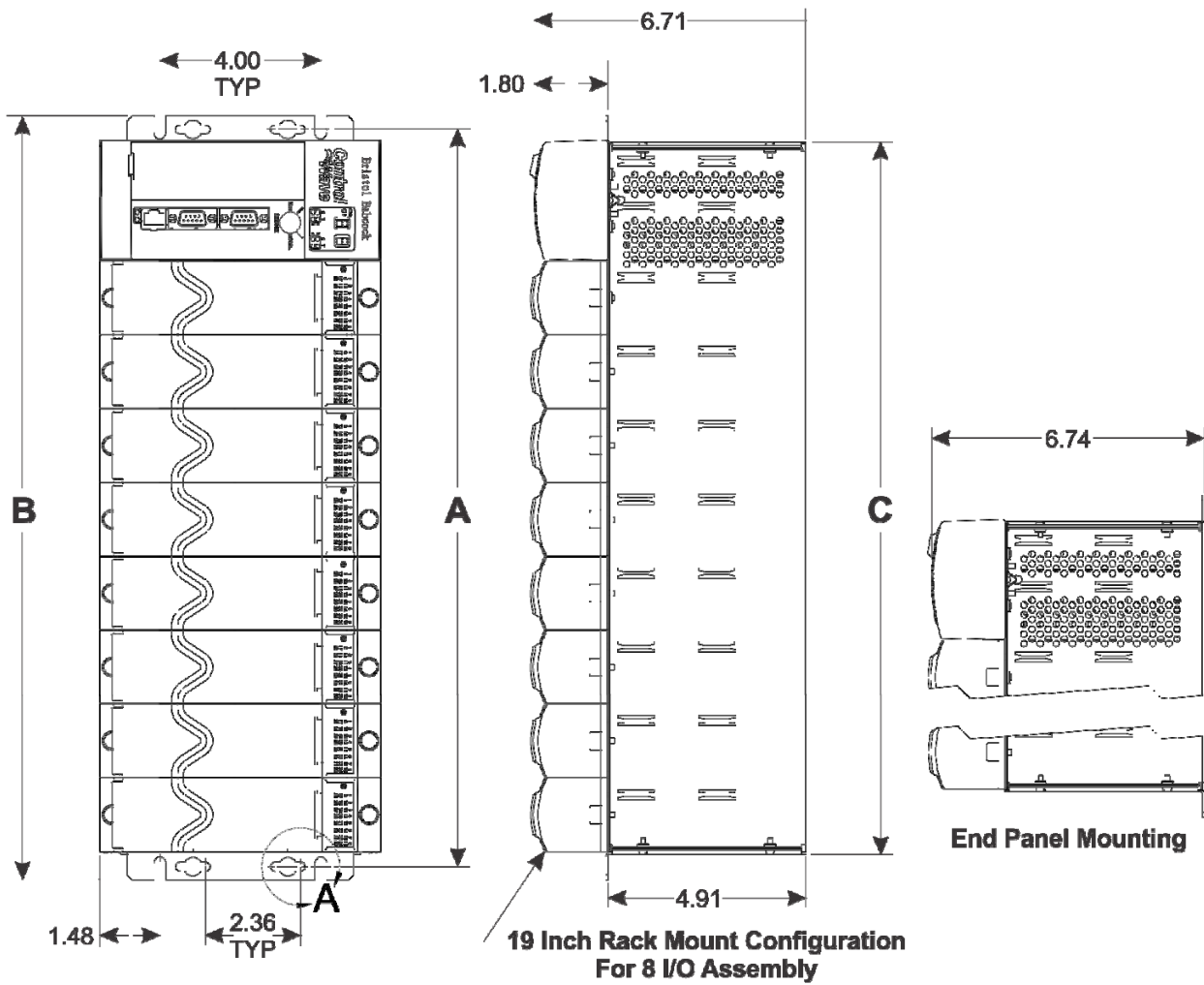

Figure 2-6. 4-I/O Module ControlWave - Mounting Diagram (dimensions in inches)



ASSEMBLY	DIM. A	DIM. B	DIM. C
8 I/O Modules	18.31	18.98	17.70
4 I/O Modules	10.98	11.65	10.37
2 I/O Modules	7.31	7.98	6.70

2 I/O modules no longer available

All Dimensions Are In Inches

Figure 2-7. 4-I/O Module ControlWave - Mounting Diagram

2.2.4 Grounding the Housing

 **Caution** Do not install any modules in the housing until you mount and ground the housing at the designated installation site.

Housings have a ground lug that accommodates up to a #4 AWG wire size. Once you install the housing, you must run a ground wire between the housing ground lug and a known good earth ground.

When you install the various ControlWave modules into the housing and secure them using the captured panel fasteners, this automatically connects them to chassis ground.

Note: After you install the PSSM in the housing, as an added precaution we recommend that you run a #14 AWG wire from the TB2-3 power connection (chassis ground) to the same known good earth ground.

Additional grounding guidelines include:

- Use stranded copper wire (#4 AWG) for the housing to earth ground, and keep the length as short as possible.
- Clamp or braze the ground wire to the ground bed conductor (typically a stranded copper AWG 0000 cable installed vertically or horizontally).
- Tin the wire ends with solder (using a high-wattage soldering iron) prior to inserting the wire into the housing ground lug.
- Run the ground wire so that any routing bend in the cable has a minimum radius of 12-inches below ground and 8-inches above ground.

2.3 Power Supply/Sequencer Module (PSSM)

Before we actually install the PSSM in the housing, we're going to discuss some general information about how it works.

2.3.1 General Information about the PSSM

The Power Supply/Sequencer module (PSSM) takes power from an external bulk DC power supply and then provides power through the ControlWave housing/backplane to all installed modules.

The PSSM is used in the following ControlWave models:

- ControlWave Process Automation Controller
- ControlWave I/O Expansion Rack
- ControlWave Redundant Controller

The PSSM plugs into slot #1 (first slot from the left) on the ControlWave's backplane using connector J1.

The PSSM provides your ControlWave with dual power supplies for operational redundancy.

Note: You can optionally purchase the PSSM with only a single power supply installed, however, this configuration does not allow for redundancy within the PSSM which is discussed throughout this section.

The PSSM includes two independent power supplies. Should either power supply fail, operations automatically continue using the second supply, and you can “hot-swap” the failed power supply with a spare unit without interrupting control operations. The PSSM also supports hot swapping of I/O modules. However, you cannot replace the entire PSSM itself without first turning off power to the ControlWave.

When used as part of a redundant system, the failure of one of the two power supplies in a redundant power supply sequencer module would not force a failover to the other controller. Only the loss of both power supplies on the redundant power supply sequencer module would trigger a failover.

Power Supply The PSSM ships from the factory configured for a nominal input supply of 24Vdc.

 **WARNING** Do not perform “hot swapping” in a Class I, Division 2 hazardous location.

Hot Swap of I/O Modules The PSSM supports “hot swapping” of I/O modules. This means you can insert or remove an I/O module from the chassis while power is live.

Hot Swapping of Power Supplies There is **no** support for “hot swapping” of the entire PSSM itself, or the CPU module, however, if you have the dual power supply version, you can hot swap a power supply **on** the PSSM. For information on hot swapping of power supplies see *Section 2.3.6*.

Watchdog Switch PSSMs include a watchdog metal oxide semiconductor field-effect transistor (MOSFET) switch connector. The purpose of the watchdog connector is to trigger an external alarm or annunciator if the ControlWave enters a “watchdog” condition in which the CPU cannot control your process. This occurs on power-up before the ControlWave project starts, if the unit is reset, if the ControlWave project “crashes” or if the system loses power. See *Section 2.3.7*.

Redundancy Control Input

The same terminal block (TB3) used for watchdog control also handles a redundancy control line to a ControlWave Redundant I/O Switcher. If this ControlWave I/O expansion rack is part of a redundant pair, and the ControlWave Redundancy Switcher detects a watchdog failure in the **other** ControlWave I/O rack, the redundancy control input sends signals to **this** ControlWave I/O rack that it must take control. For more information on how this works, see the *ControlWave Redundancy Setup Guide* (D5123) and the *ControlWave Redundant I/O and Control Switch Unit Manual* (CI-ControlWave REDI/O).

2.3.2 PSSM Installation Overview

There are several steps you need to follow when you install the PSSM.

1. Identify the carton holding the PSSM and remove it from that carton. See *Section 2.2.1*.
2. If needed, set jumpers. See *Section 2.3.3*.
3. Slide the PSSM into slot #1 of the housing.

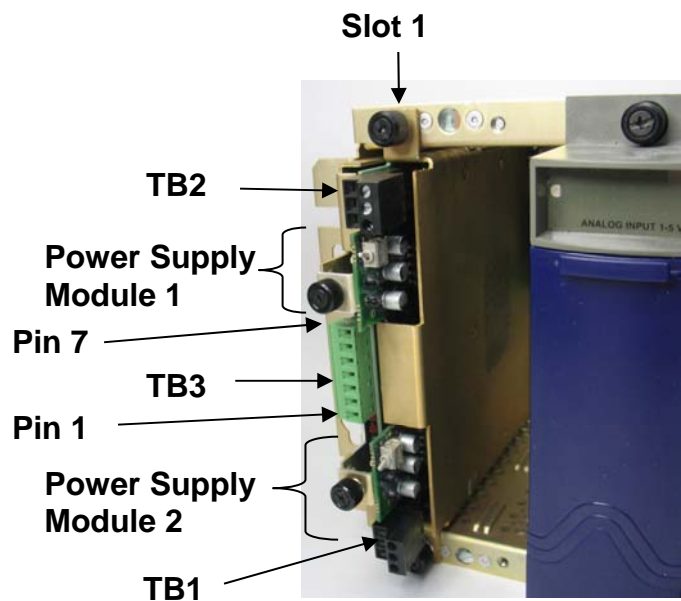

Figure 2-8. PSSM Installed in ControlWave Slot #1 of a ControlWave Controller

4. Tighten the captive panel fasteners to secure the PSSM in place.
5. Unplug terminal block connectors TB1 and TB2 from the PSSM and wire them to an external bulk DC power supply. See *Section 2.3.5*.
6. If you want to use the watchdog connector TB3, or use this ControlWave in a redundant system, unplug TB3 from the PSSM and wire it to an external annunciator or similar device according to instructions in *Section 2.3.7*.
7. After you configure and install the CPU module in slot #2 re-connect terminal blocks to their connectors to apply power to the unit.

2.3.3 Setting Jumpers

Depending upon how you are using the PSSM, you may have to change one or more jumpers from their factor default positions. See *Table 2-1* for a list of the jumpers and their functions; see *Figure 2-10* for jumper locations.

Table 2-1. PSSM Jumpers

Jumper	Position	Description
JP1	1-2	Enables the watchdog circuitry. This is the default . Watchdog wiring is discussed later in this document.
	2-3	Disables the watchdog circuitry.
JP2	1-2	Sets the PSSM as always the on-line unit. This is the default . Use this setting if the PSSM is not installed in a redundant system.
	2-3	Specifies that the PSSM is part of a redundant system. Choose this position if the PSSM is installed: In a ControlWave Redundant Controller or In a ControlWave Controller that is part of a redundant pair or In a ControlWave I/O Expansion Rack that is part of a redundant pair.
JP3	1-2	Enables the 12V monitor. This is the default . When enabled, the PSSM reports a failure when voltage falls below 12V and lights the PWR Down LED to indicate the failure.
	2-3	Disables the 12V monitor. When disabled, the PSSM does not report a failure if voltage falls below 12V.

If you need to change the jumper positions, unscrew the protective case from the PSSM using a Phillips screwdriver (see *Figure 2-9*).

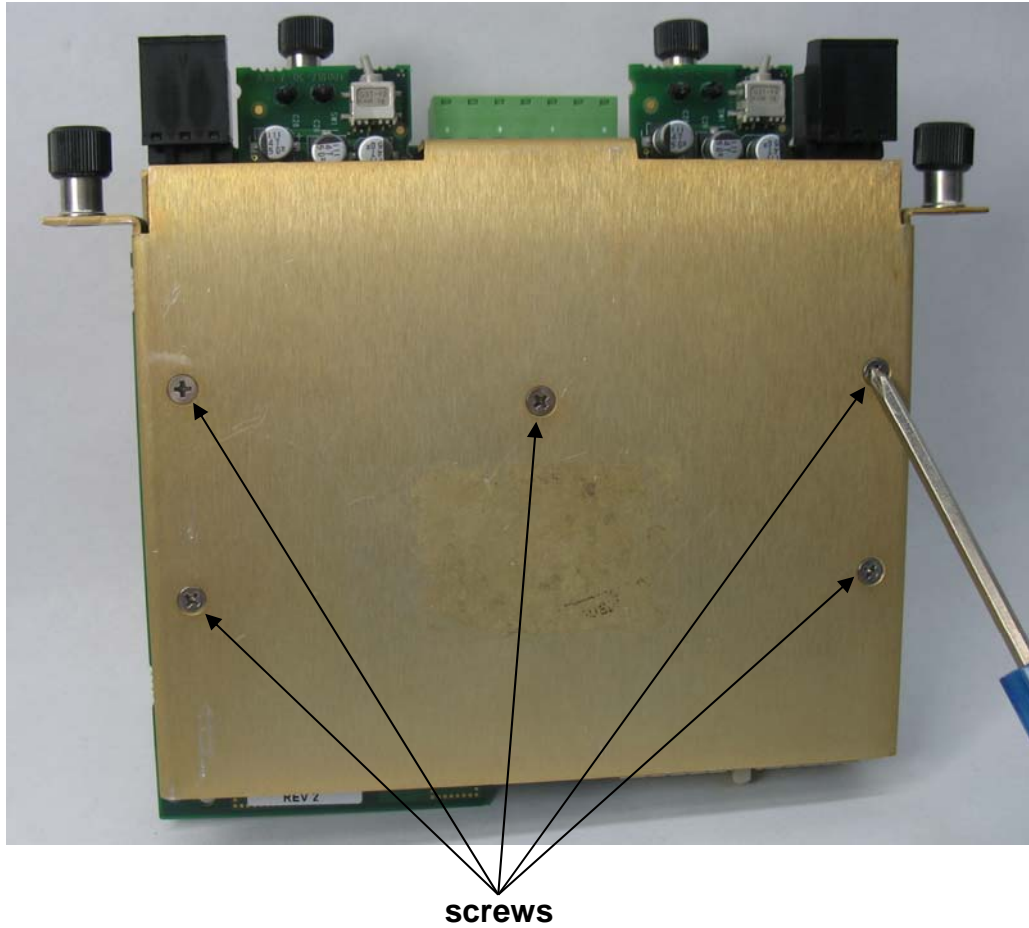

Figure 2-9. Removing the Protective Case from the PSSM

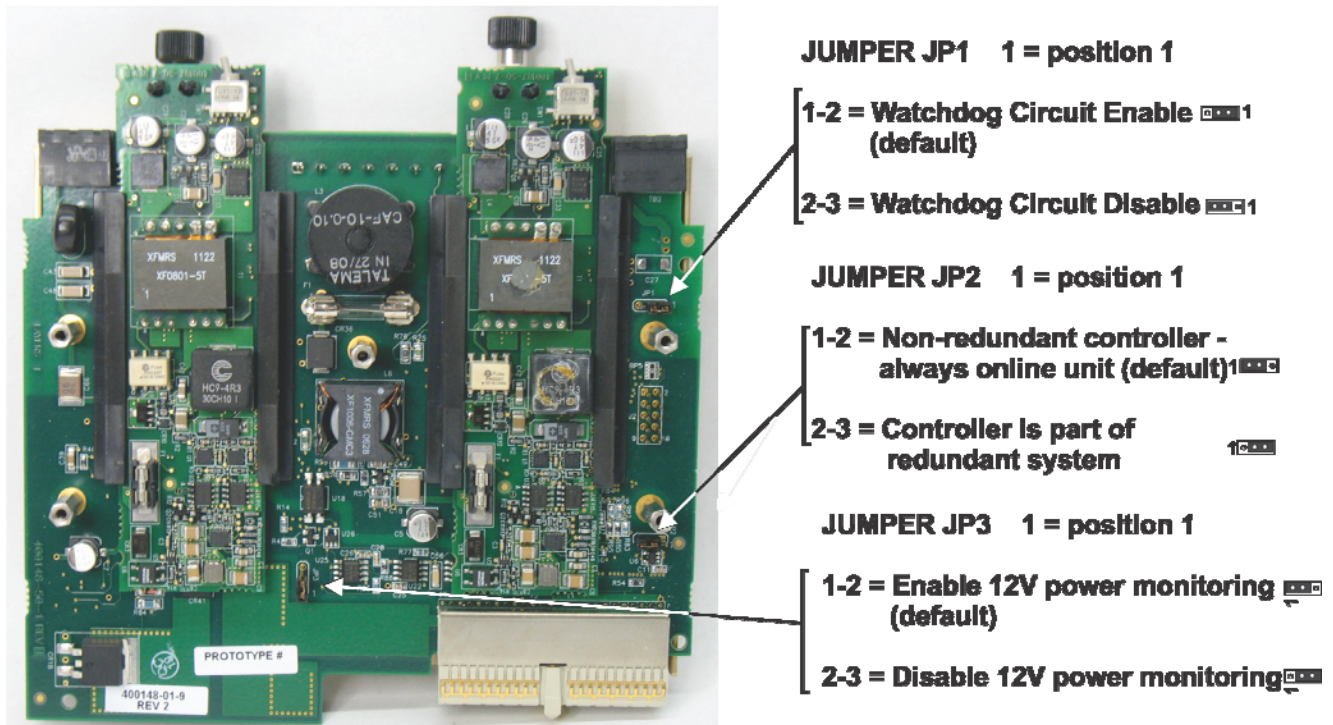

Figure 2-10. Jumper Locations

Make the necessary adjustments to the jumpers according to *Table 2-1*. When finished, re-attach the case by first aligning the protective case with the screw holes, then inserting and tightening each screw.

2.3.4 General Wiring Guidelines

- ControlWave PSSMs use compression-type terminals that accommodate up to #14 AWG wire.
- When making a connection, insert the bare end of the wire (approx ¼" max) into the clamp adjacent to the screw and secure the wire.
- To prevent shorts, ensure that no bare wire is exposed. If using standard wire, tin the bare end with solder to prevent flattening and improve conductivity.
- Allow some slack in the wire while making terminal connections. Slack makes the wires more manageable and helps minimize mechanical strain on the terminal blocks.

2.3.5 Wiring a Bulk DC Power Supply to the PSSM

Caution

At this time you can also connect power and watchdog wiring. However; for safety reasons and to prevent accidental damage to the your bulk DC power supply, do not connect the pluggable terminal block connectors TB1 and TB2 (or TB3) to the PSSM until after you install, wire, and configure the CPU module.

Follow the instructions in *Section 2.3.4* when wiring connections.

Operating Range	The ControlWave operates from +22.2 Vdc to +30.0 Vdc (with a nominal +24Vdc input source).
One or Two Power Supplies	<p>You can connect one or two bulk DC power supplies (nominally +24 Vdc) to the PSSM. Use terminal blocks TB1 and TB2 to connect an external bulk power supply to the PSSM.</p> <p>The external bulk 24V DC power supply you connect to TB1-1 (+VIN) provides system power to the ControlWave including the CPU boards, communications and I/O boards (see <i>Figure 2-11</i>). The PSSM converts, regulates, and filters the power to +5Vdc, +3.3Vdc, +12Vdc (optional) and -12Vdc (optional). +3.3 Vdc. For safety, this circuit has a 3A fuse.</p> <p>The bulk DC supply you connect to terminal TB2-1 (+VINF) powers the I/O field devices connected to the I/O modules. For safety, this circuit has a 10A fuse.</p>

Notes:

- When you require two bulk power supplies, the first supply (VIN) must be rated to handle 2 amps.
- Be sure you route wires to the terminal block connectors so they do not interfere with removal/replacement of the power supply modules.
- The fuses for the PSSM **cannot** be replaced in the field.



Figure 2-11. Wiring System Power to the PSSM

An external power supply (22.2 to 30V) connected to **TB2** provides field power to I/O boards, and any field devices (switches, relays, etc.) powered through the I/O boards (see *Figure 2-12*).



Figure 2-12. Wiring Field Power to the PSSM

Calculating the Maximum Current Required Use the following formula to determine the maximum current required for the +24 Vdc bulk power used with a particular ControlWave I/O Expansion Rack:

$$\text{Max Bulk +24 Vdc Supply Current} = \text{CPU}_{\text{max_current}} + \sum \text{I/O Module}_{\text{max_current}}$$

where:

$\text{CPU}_{\text{max_current}}$	refers to the maximum current required by the CPU (with or without an SCB), backplane and the PSSM. This is 1A.	
$\sum \text{I/O Module}_{\text{max_current}}$	refers to the sum of the maximum current required by each and every I/O module installed in the unit. The amount per I/O module varies as follows:	
	16 AI Module	2A per module
	8 AI Module	1A per module
	8 AO Module	1A per module
	16 DI Module	1A per module
	32 DI Module	1A per module
	16 DO Module	See table (no surge current)
	32 DO Module	See table (no surge current)
	6 UDI Module	See table (no surge current)
	4 RTD Module	See table (no surge current)
	6 LLAI Module	See table (no surge current)

So, for example, if you have a ControlWave I/O rack with a 16AI module, an 8AO module, and a 32DI module, the maximum current draw is 1A for the CPU plus 2A for the 16AI module plus 1A for the 8AO module and 1A for the 32DI module, for a total of 5A.

Note: This calculation covers current draw during normal operation (steady state) as well as the current draw during power-up in-rush when the unit is first powered on. Power up in-rush current can last up to 100 milliseconds and is higher than the current draw required during normal operation.

Refer to *Table 2-2* for ControlWave steady state and loop current requirements for bulk power supplies.

Table 2-2. Steady State Current Draw for Bulk Power Supplies

Component(s)	System Current draw for 24Vdc Power Supply	Field Current draw for 24Vdc Power Supply	Notes
CPU (with Ethernet), PSSM and backplane	290 mA	Not applicable	
CPU (with Ethernet), SCB (with 2 Ethernet, 1 RS 485 and 1 RS 232), PSSM and backplane	400 mA	Not applicable	
Analog Input Module 16 points (4-20 mA)	40.5 mA	52.2 mA	For 24Vdc supply add 25 mA per loop
Analog Input Module 8 points (4-20 mA)	36.1 mA	29.7 mA	For 24Vdc supply add 25 mA per loop
Analog Output Module 8 points (4-20 mA)	20.0 mA	26.9 mA	For 24Vdc supply add 23.6 mA per loop
Analog Output Module 8 points (1-5V)	20.0 mA	56.8 mA	For 24Vdc supply add 26.1 mA per loop. Output at 5 mA
Digital Input Module 32 points	29.2 mA	29.7 mA	For 24Vdc supply add 4.74 mA per loop – dry contact
Digital Input Module 16 points	15.8 mA	29.7 mA	For 24Vdc supply add 4.74 mA per loop – dry contact
Digital Output Module 32 points	42.6 mA	0 mA	
Digital Output Module 16 points	22.6 mA	0 mA	
Universal Digital Input (UDI) – 6 points	16.7 mA	0 mA	
Isolated RTD 4 point	26.0 mA	0 mA	
Isolated Low Level Analog Input 6 points	40.0 mA	0 mA	

Note: As an added precaution, we recommend that you run a #14 AWG wire from the TB2-3 power connection (chassis ground) to the same known good earth ground used for the housing.

2.3.6 Hot-swapping a Power Supply



WARNING

DO NOT ATTEMPT hot swapping in a Class I, Division 2 hazardous location.

Each power supply has a Power Good indication LED (see *Chapter 5*). If this light goes out while the power supply is on, the power supply's output voltage is out of specification. This could occur if the supply is not properly seated in the slot or if its fuse has blown. Remove the power supply to check for these conditions. If neither condition has occurred, you may need to replace the power supply.

To remove one of the power supplies, first turn the power supply's ON/OFF switch **off** (the down position, as shown in *Figure 2-13*). Loosen the plastic screw either by hand or with a Phillips screwdriver. Grasp the bracket and gently pull the power supply straight out of the assembly.

ON/OFF switch for power supply

OFF = down position (shown)
ON = up position

Bracket

Screw

Loosen the screw and grasp the bracket to slide the power supply out of the PSSM.

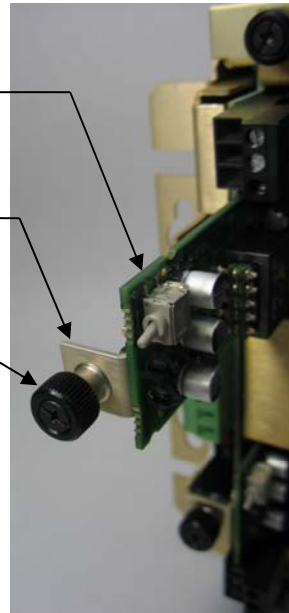

Figure 2-13. Hot Swapping a Power Supply

To re-insert the power supply, grasp the bracket and line up the board with the grooves in the assembly. Gently slide the card into the PSSM until it inserts into the connector. Gently tighten the screw either by hand or with a Phillips screwdriver. Now turn the On/Off switch **on** (the up position).

2.3.7 Wiring an External Alarm or Annunciator to the Watchdog Connector and Wiring the Redundancy Control Input (OPTIONAL)

Caution At this time you can also connect power and watchdog wiring. However; for safety reasons and to prevent accidental damage to the your bulk DC power supply, do not connect the pluggable terminal block connectors TB1, TB2, or TB3 to the PSSM until after you install, wire, and configure the CPU module.

Follow the instructions in *Section 2.3.4 General Wiring Guidelines* when wiring connections.

When the CPU's hardware detects improper software operation, it triggers a watchdog condition and resets the CPU. If you have enabled the watchdog output using jumper JP1, the watchdog condition triggers a failure to the redundant unit.

The circuit that drives the watchdog switch is on the secondary side of the power supply. A solid state relay actuates the watchdog hardware and is factory enabled or disabled via jumper JP1 (see *Setting Jumpers*).

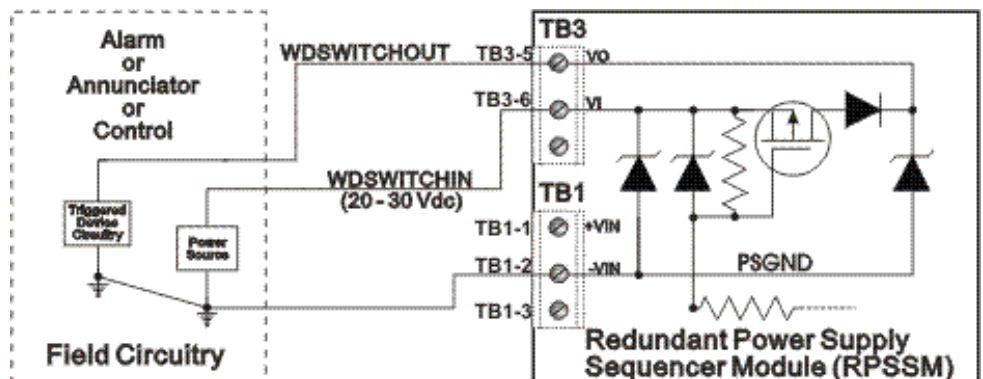

Figure 2-14. Watchdog Switch Field Wiring

The VI input of the terminal block (TB3-6) powers the watchdog switch. Its switched output connects to the VO output of the terminal block (TB3-5). Reference the external power source connected to the VI terminal to the return point of the input source that powers the PSSM [-VIN (TB1-2)].

PSSM connector TB3 provides watchdog switch and redundancy control connections as follows:

Connections

- TB3-5 = VO - Watchdog switch output
- TB3-6 = VI - Watchdog switch input
- TB3-7 = VR - Redundant unit control input (Used with CW RED I/O)

When using a pair of ControlWave I/O expansion racks, each with a PSSM, and a ControlWave Redundant I/O and Communications Switch Unit (the redundant I/O switcher), the choice of which unit is “online” and which unit is “backup” is determined by redundancy control line wiring between the ControlWave I/O redundancy control module (IORCM) on the I/O switcher, and each I/O expansion rack (See *Figure 2-15*).

Wire terminal block connector TB3-7 on the “A” I/O expansion rack PSSM to TB2-1 on the IORCM, and TB2-2 on the IORCOM to 24V.

Similarly, wire terminal block connector TB3-7 on the “B” I/O expansion rack PSSM to TB2-3 on the IORCM, and TB2-4 on the IORCOM must to 24V.

Figure 2-16 shows the location of the IORCM connectors on the ControlWave I/O Switcher.

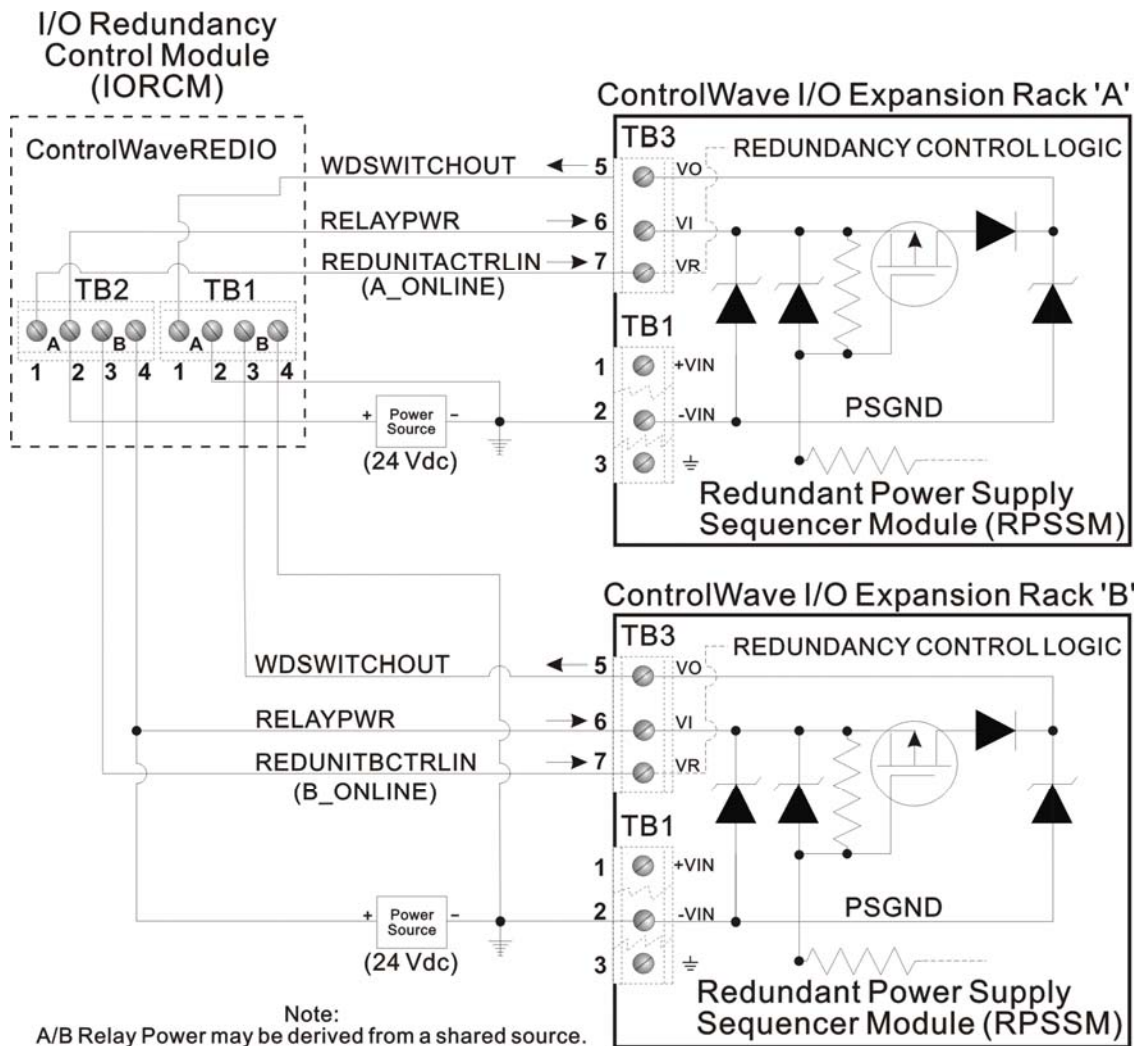

Figure 2-15. ControlWave to ControlWave REDI/O - Redundancy Field Wiring

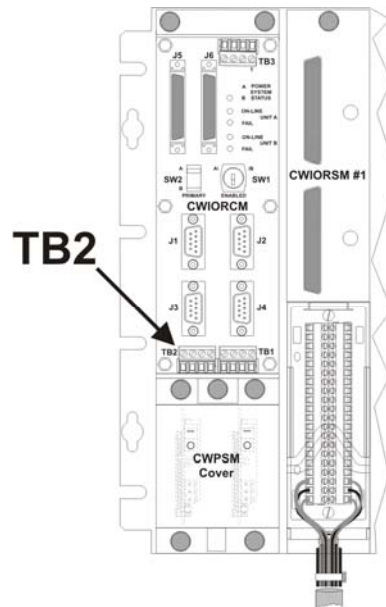

Figure 2-16. Location of TB2 on ControlWave I/O Switcher

2.3.8 Wiring Digital Inputs to indicate Power Supply Failure

Each power supply on the PSSM drives a solid state relay contact closed during normal operation. In a failure, this contact opens. You can optionally wire the contact to a digital input (either externally or internally sourced) to provide indication of a power supply failure. You must wire the contact differently depending upon whether the digital input supports internally sourced or externally sourced power. See *Table 2-3* for details.

Table 2-3. Wiring a Digital Input to Indicate Power Supply Failure

Power Supply	Digital Input (Internally Sourced)	Digital Input (Externally Sourced)
1	TB3-3 SYSTEM GND TB3-4 DIGITAL INPUT	TB3-3 SYSTEM PWR TB3-4 DIGITAL INPUT
2	TB3-1 SYSTEM GND TB3-2 DIGITAL INPUT	TB3-1 SYSTEM PWR TB3-2 DIGITAL INPUT

2.3.9 PSSM Specifications

Table 2-4. PSSM Specifications

Redundant Power Supply Sequencer Module

Input Range:	22.2 to 30V DC (24V input supply, nominal) Shutdown occurs at 22.2 nominal for 24V input supply systems, respectively.
Temperature Range:	Operating: -40 to 70 ° C Storage: -40 to 85 ° C
Relative Humidity:	15 to 95% non-condensing
Vibration:	1G for 10-150 Hz 0.5 G for 150 Hz to 2000 Hz
RFI Susceptibility	3V/m 80 MHz to 1000 MHz per EN50082-2
Watchdog MOSFET	1A

Power Supplies (1 or 2 on the PSSM)

Input Range	20 to 30Vdc (24V input supply, nominal)
Output Voltage	5V ± 2%, 3.3V ± 2%
Output Current	1A @ 3.3V, 2A @5V
Efficiency	75% at full load
Fusing	7x2 mm fuse 3A fast acting

Field Supply Power

VINF Input Range	20V to 30V
Fusing	5x20 mm fuse 10A slow blow

2.4 CPU Module

The CPU module, which controls the ControlWave I/O Expansion Rack and handles memory and communication functions, can only be installed in Slot #2 of the backplane.

Identify the carton holding the CPU module and remove it from that carton. The CPU module has two different configurations, depending upon whether or not you ordered the CPU with a secondary communications board (SCB):

- CPU with two RS-232 serial ports, and one Ethernet port. No SCB.
- CPU with two RS-232 serial ports, and one Ethernet port. SCB with one additional RS-232 port, one RS-485 port, and two additional Ethernet ports.

Set DIP switches on the CPU module according to the tables on the next few pages. After you configure the DIP switches, slide the CPU module into slot #2 (the second slot from the left) of the housing.

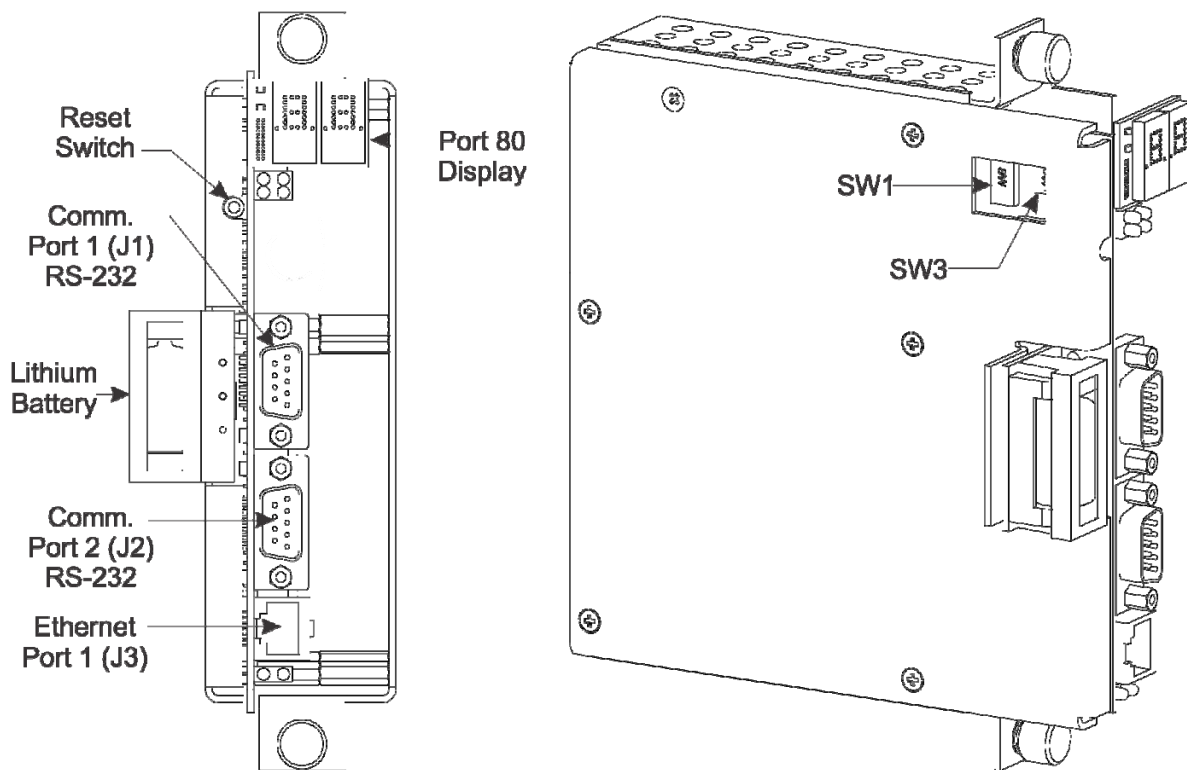

Figure 2-17. ControlWave I/O Expansion Rack CPU Module (without SCB)

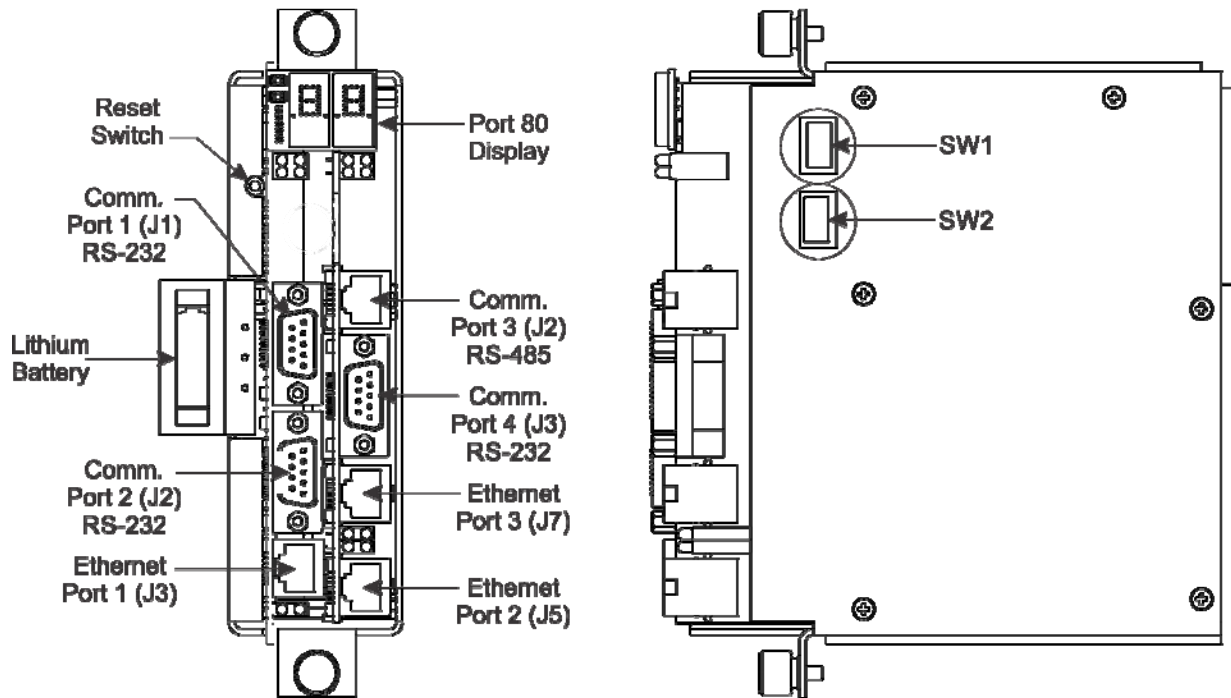

Figure 2-18. ControlWave I/O Expansion Rack CPU Module (with SCB)

2.4.1 Setting DIP Switches on the CPU Module

Before you install the CPU module, you must determine the settings for its DIP switches. Refer to *Figure 2-17* for the location of the DIP switch banks on the CPU board itself. If you have a secondary communications board (SCB) you must also refer to *Figure 2-18* for the location of the DIP switch banks on the SCB. Refer to *Tables 2-5* through *2-6* for DIP switch settings on the CPU board and the SCB.

Note: Examine each bank of DIP switches carefully to note the switch direction for ON or OFF.

Table 2-5. CPU Board Switch SW1

SW1 Setting	Function	Mode
1	Watchdog Enable	Controls whether the system enters a watchdog state when a crash or system hangup occurs and automatically restarts. Values are: ON (Enables watchdog circuit; factory default) OFF (Disables watchdog circuit and prevents automatic restart)
2	Lock/Unlock Soft Switches	Controls the ability to modify soft switches, other configurations, and flash files. Values are: ON (Unlocks soft switches and flash files; factory default). OFF (Locks soft switches, configurations, and flash files)
3	Use/Ignore Soft Switches	Controls the use of soft switches. Values are: ON (Enable user-defined soft switches configured in flash)

SW1 Setting	Function	Mode
		memory; factory default) OFF (Disable soft switch configuration and use factory defaults)
4	Core Updump (see <i>Section 3.6</i>)	Causes the ControlWave to perform a core updump, provided you have set the mode switch (SW3-3) to Recovery mode. Values are: ON (Disables core updump; factory default) OFF (Core updump via PSSM Run/Remote/Local switch or mode switch SW3-3)
5	SRAM Control	Manages SRAM contents following a low power situation or a power outage. Values are: ON (Retain values in SRAM during restarts; factory default) OFF (Reinitialize SRAM) – Data in SRAM lost during power outage or re-start.
6	Redundancy Enable / Disable	Specifies whether this ControlWave is part of a redundant pair. Values are: ON (Redundancy Disabled. Not part of redundant pair; factory default) OFF (Redundancy Enabled. This ControlWave is one of two in a redundant pair)
7	Unit A / Unit B	Specifies whether this ControlWave is the “A” or “B” unit in a redundant pair. Values are: ON (“A” unit in the redundant pair; factory default) OFF (“B” unit in the redundant pair) Note: If SW1-6 is ON , the system ignores SW1-7.
8	Enable WINDIAG	Suspends normal operation and allows diagnostic routines. Values are: ON (Permits normal system operation, including the boot project, and disables the WINDIAG diagnostics from running; factory default) OFF (Allow WINDIAG to run test; disable boot project.)

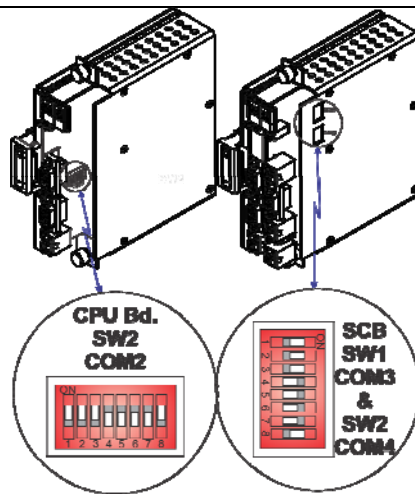

Figure 2-19. CPU Module Communication Port Switches

Table 2-6. CPU Board Switch SW3

SW3 Setting	Function	Mode
1	N/A	Not currently used.
2	System Firmware load control	Enables / disables remote system firmware upgrade via System Firmware Downloader: ON (disables remote system firmware upgrade) OFF (enables remote system firmware upgrade; factory default) Note: Remote system firmware upgrade using System Firmware Downloader requires boot PROM version 06 (or newer) and system PROM version 4.7 (or newer).
3	Force Recovery Mode	Enables recovery mode. This allows for system firmware upgrades. Values are: ON (enables recovery mode) OFF (disables recovery mode). – This is the factory default .
4	Backup Battery Enable/Disable	Enables/disables the backup battery for SRAM and the real-time clock. Values are: ON (enables backup battery) OFF (disables backup battery). – This is the factory default . Note: The unit ships from the factory with the backup battery disabled to conserve battery power. Set this to ON when you install the CPU.

Notes:

- *Table 2-7* describes switch settings for SW1 on the SCB board which controls the RS-485 port (COM3) of the SCB. You may want to review *Section 2.4.3* before you set these switches.
- *Table 2-8* describes switch settings for SW2 on the SCB board; this controls the RS-232 port (COM4) of the SCB.

Table 2-7. SCB Port Configuration Switch SW1 (For COM3)

SW1 Switch Number	Function for COM3 (RS-485) on the SCB
1	ON TX+ to RX+ Loopback (Use for Diagnostics or 2-wire only) OFF No loopback (factory default)
2	ON TX- to RX- Loopback (Use for Diagnostics or 2-wire only) OFF No loopback (factory default)
3	ON 100 Ohm RX+ termination (end node only) OFF Not an end node (factory default)
4	ON 100 Ohm RX- termination (end node only) OFF Not an end node (factory default)
5	Not currently used

SW1 Switch Number	Function for COM3 (RS-485) on the SCB
6	ON (Fast slew rate enabled) (factory default) OFF (Slow slew rate enabled)
7	ON RX+ bias (end node only) OFF Not an end node (factory default)
8	ON RX- bias (end node only) OFF Not an end node (factory default)

Table 2-8. SCB Port Configuration Switch SW2 (For COM4)

SW2 Switch Number	Function for COM4 (RS-232) on SCB
1	ON DTR to DSR Loopback (Use for Diagnostics only) OFF No loopback (factory default)
2	ON TXD to RXD Loopback (Use for Diagnostics only) OFF No loopback (factory default)
3	Not currently used
4	Not currently used
5	ON RTS to CTS Loopback (Use for Diagnostics only) OFF No loopback (factory default)
6	Not currently used
7	Not currently used
8	Not currently used

After you set the DIP switches and insert the CPU module in slot #2 of the housing, you can connect communication ports.

2.4.2 Connections to RS-232 Serial Port(s)

An RS-232 port provides point-to-point, half-duplex and full-duplex communications (for a maximum of 20 feet using data quality cable).

The standard CPU module includes two RS-232 ports. If you purchased your CPU module with a secondary communication board (SCB) you may have one additional RS-232 port.

RS-232 COM Port Names and Connectors

RS-232 COM ports are assigned names based on their location in the ControlWave I/O Expansion Rack. The CPU board has two RS-232 ports (COM1 and COM2). See *Table 2-9*.

Table 2-9. RS-232 Connectors on CPU Board

Connector	Name	Function	Notes
J2	COM1	9-pin male D-sub (RS-232)	See <i>Figure 2-18</i> , <i>Figure 2-20</i> , & <i>Table 2-11</i>

Connector	Name	Function	Notes
J3	COM2	9-pin male D-sub (RS-232)	See <i>Figure 2-18, Figure 2-20, & Table 2-11</i> If you purchased an SCB board, it includes an RS-232 port. If present, the RS-232 port on the SCB is COM4.

Table 2-10. RS-232 Connector on Secondary Communications Board (SCB)

Connector	Name	Function	Notes
J3	COM4	9-pin male D-sub (RS-232)	See <i>Figure 2-18, Figure 2-20 & Table 2-11</i>

RS-232 COM Port Cables

For the ControlWave, half-duplex communications use BSAP protocol or another protocol such as Modbus, while full-duplex communications use point-to-point protocol (PPP). RS-232 ports use a “null modem” cable (see *Figure 2-21*) to connect with other devices (such as a PC, a printer, another ControlWave [except the CW_10/30/35]) when the ControlWave uses the full-duplex PPP protocol.

If you don’t want to make your own cables, as described in this section, you can purchase cables.

- You can purchase a null modem cable using part number 392843-01-3.

Note: You can configure the ControlWave as either a master or slave node on a BSAP network.

Figure 2-20 illustrates the CPU module’s male 9-pin D-type connector. Use the content provided in *Table 2-11* to determine pin assignments for the COM1, COM2, and COM4 ports.



Figure 2-20. Male DB9 9-Pin Connector

Table 2-11. COM1, COM2, COM4 RS-232 Port Connector Pin Assignment

Pin	RS-232 Signal	RS-232 Description
1	DCD	Data Carrier Detect Input
2	RXD	Receive Data Input
3	TXD	Transmit Data Output
4	DTR	Data Terminal Ready Output
5	GND	Signal/Power Ground
6	DSR	Data Set Ready Input
7	RTS	Request to Send Output

Pin	RS-232 Signal	RS-232 Description
8	CTS	Clear to Send Input
9	RI	Ring Indicator

Use the “null modem” cable for full-duplex (PPP protocol) communications when connecting a ControlWave to a PC. (See top part of *Figure 2-21*.)

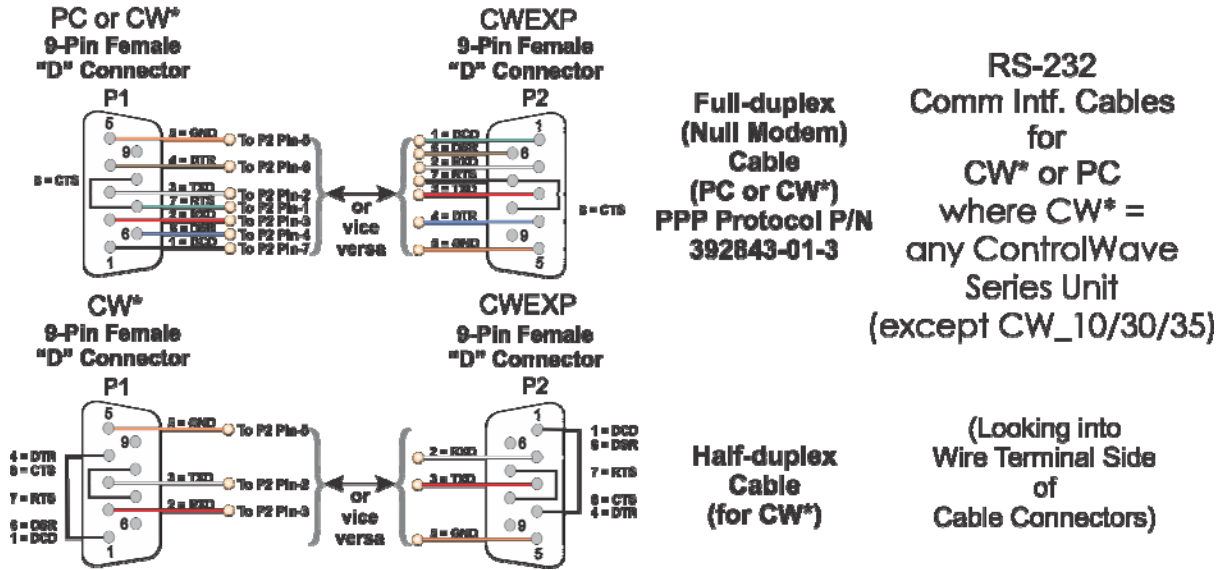

Figure 2-21. Full-duplex and Half-duplex Cable

Use the half-duplex cable (shown in the bottom part of *Figure 2-21*) when connecting the ControlWave to another ControlWave series unit (again, with the exception of the CW_10/30/35 units).

RS-232 Cable Guidelines

Observe the following guidelines when constructing RS-232 communication cables:

- Ensure that DCD is high to transmit
- Set CTS to high to transmit.
- If the port is set for full-duplex operation, RTS is always ON.
- Ensure that DTR is always high when port is active
- When port is set for half-duplex operation, CTS must go low after RTS goes low.

2.4.3 Connections to RS-485 Serial Port on the Secondary Communication Board (SCB)

The RS-485 port supports local network communications to multiple nodes up to 4000 feet away.

If you purchased your CPU module with a secondary communication board (SCB) you have a single RS-485 port.

RS-485 COM Port Name and Connector

COM3 on the SCB board is an RS-485 port.

Table 2-12. RS-485 Connectors on SCB

Connector	Name	Function	Notes
J2	COM3	8-pin RJ-45 (RS-485)	See Figure 2-22 & Table 2-13

RS-485 COM Port Cables

Figure 2-22 shows the RJ-45 connector used for COM3 on the SCB. If you ordered the SCB. See Table 2-13 for pin assignments.

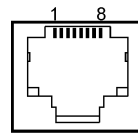

Looking into
receptacle

Figure 2-22. RJ-45 Connector Associated with COM3, ETH2, ETH3 (all on SCB)

Table 2-13. RS-485 COM3 Port (RJ-45) Connector Pin Assignment

Pin	RS-485 Signal	RS-485 Description
1		
2	RXD+	Receive Data + Input
3	RXD-	Receive Data – Input
4		
5	TXD-	Transmit Data – Output
6		
7	TXD+	Transmit Data + Output
8	ISOGND	Isolated Ground

Since the RS-485 port is intended for network communications, refer to Table 2-14 for the appropriate connections for wiring the master, first slave, and *n*th slave.

Essentially, the master and the first slave transmit and receive data on

opposite lines; all slaves (from the first to the *nth*) are paralleled (daisy-chained) across the same lines. Wire the master node to one end of the RS-485 cable run using a 24-gauge paired conductor cable (such as a Belden 9843).

Note: ControlWave **only** supports half-duplex RS-485 networks.

Table 2-14. RS-485 Network Connections

From Master	To First Slave	To nth Slave
TXD+	RXD+	RXD+
TXD-	RXD-	RXD-
RXD+	TXD+	TXD+
RXD-	TXD-	TXD-
ISOGND	ISOGND	ISOGND

To ensure that the “Receive Data” lines are in a proper state during inactive transmission periods, you must maintain certain bias voltage levels at the master and most distant slave units (end nodes). These end nodes also require the insertion of 100Ω terminating resistors to properly balance the network.

You must also configure secondary communication board switches at each node to establish proper network performance. Accomplish this by configuring switches listed so that the 100Ω termination resistors and biasing networks are installed at the end nodes and are removed at all other nodes on the network. You enable receiver biasing and termination using SCB switch SW1 (for COM3). See *Table 2-7 in Section 2.4.1 Setting DIP Switches on the CPU Modules* for information on RS-485 termination and loopback control switch settings.

2.4.4 Connections to Ethernet Port(s) on the CPU Module

The ControlWave can support either one or three Ethernet ports. These use a 10/100Base-T RJ-45 modular connector that provides a shielded twisted pair interface to an Ethernet hub. Two LEDs per port provide transmit and receive status indications:

Table 2-15 shows port assignments for the Ethernet ports.

Table 2-15. Ethernet Ports

Connector	Name	Function	Notes
J4 on CPU board	Ethernet Port 1 (ETH1)	8-pin RJ-45 (RS-485) – Shielded Twisted Pair 10/100Base-T	
J5 on SCB board	Ethernet Port 2 (ETH2)	8-pin RJ-45 (RS-485) – Shielded Twisted Pair 10/100Base-T	Requires SCB board
J7 on SCB board	Ethernet Port 3 (ETH3)	8-pin RJ-45 (RS-485) – Shielded Twisted Pair 10/100Base-T	Requires SCB board

A typical Ethernet hub provides eight 10/100Base-T RJ-45 ports (with port 8 having the capability to link either to another hub or to an Ethernet communications port). Both ends of the Ethernet twisted pair cable are equipped with modular RJ-45 connectors.

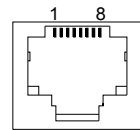

Looking into receptacle

Figure 2-23. RJ-45 Ethernet Connector

These cables have a one-to-one wiring configuration as shown in *Figure 2-24*. *Table 2-16* provides the assignment and definitions of the 8-pin 10/100Base-T connectors.

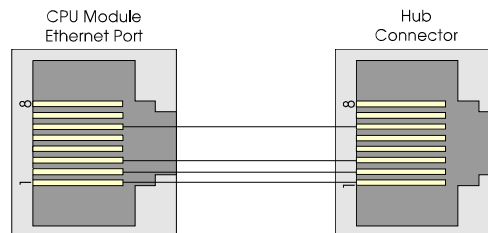

Figure 2-24. Standard 10/100Base-T Ethernet Cable (CPU Module to Hub)

Table 2-16. Ethernet 10/100Base-T CPU Module Pin Assignments

Pin	Description
1	Transmit Data+ (Output)
2	Transmit Data- (Output)
3	Receive Data+ (Input)
4	Not connected
5	Not connected
6	Receive Data- (Input)
7	Not connected
8	Not connected

Note: You can swap TX and RX at the hub.

You can connect two nodes in a point-to-point configuration without using a hub. However, you must configure the cable so that the TX+/- Data pins connect to the RX+/- Data pins (swapped) at the opposite ends of the cable (see *Figure 2-25*).

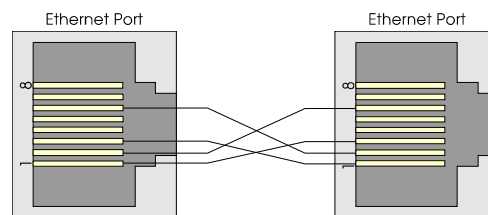

Figure 2-25. Point-to-Point 10/100Base T Ethernet Cable

The maximum length of one segment (CPU to hub) is 100 meters (328 feet). The use of Category 5 shielded cable is recommended.

2.5 Bezels

The bezel is a blue plastic cover (see *Figure 2-26*) that protects the CPU and PSSM modules. Another function of the bezel is to let you route bundled wires and cables downward between the modules and the bezel. The factory ships a version of the bezel appropriate to the options you ordered.

You should install the bezel whenever the ControlWave is operational. The bezel includes a door you can open to access the PSSM and CPU modules. If necessary, you can remove the bezel for maintenance procedures.

To install the bezel, align the two snaps on the bezel with the corresponding holders on the chassis. Once you have it positioned, push gently and the bezel snaps into place.

To remove the bezel, gently grasp its sides and pull out and away from the chassis.



Figure 2-26. Bezel Assembly (for CPU Module without SCB)

Chapter 3 – I/O Modules

This chapter discusses the placement and wiring for I/O modules in the ControlWave I/O expansion rack. The chapter begins with some general instructions on module installation and wiring guidelines that are common to most I/O modules. The balance of the chapter includes specific details for configuring and wiring each type of I/O module.

In This Chapter

3.1	Module Placement	3-3
3.2	Status LEDs	3-4
3.3	Wiring	3-4
	3.3.1 Local Termination	3-5
	3.3.2 Remote Termination	3-6
	3.3.3 Shielding and Grounding	3-6
3.4	Digital Input (DI) Modules	3-8
3.5	Digital Output (DO) Modules	3-13
3.6	Analog Input (AI) Modules	3-20
3.7	Analog Output (AO) Modules	3-25
3.8	Universal Digital Input (UDI) Modules	3-30
3.9	Isolated Resistance Temperature Device (RTD) Input Module.....	3-36
3.10	Isolated Thermocouple Module	3-40

Installation Installing any I/O module in the ControlWave I/O expansion rack involves the same basic steps:

1. Remove the I/O module from the shipping carton. I/O modules include a removable terminal housing assembly. This assembly has a door that swings downward to provide access to the unit's terminal handle you can use to remove an installed I/O module once you loosen the captive panel fasteners.

Note: Modules normally ship from the factory completely assembled.

2. Turn the terminal block's quarter turn fasteners (counterclockwise) and remove the terminal housing assembly from the I/O module (see *Figure 3-1*).
3. Wire the modules according to instructions for each individual module, included later in this chapter. I/O modules support local terminations (field wiring connected directly to the I/O module's terminal block PCB) or remote terminations (field wiring connected to a remote DIN-rail mounted terminal block assembly). See *Section 3.3.1* for information on local termination wiring and *Section 3.3.2* for information on remote termination wiring.
4. Align the I/O module with the assigned I/O slot and gently push the module into the chassis. When the assembly is fully seated, turn the I/O module's captive panel fasteners (clockwise) to secure the unit

to the chassis; this establishes a low resistance path between the I/O module and chassis ground.

5. Install the local or remote terminal block assembly (with wiring harness) onto the I/O module (turning the quarter turn fasteners (clockwise)).
6. Replace the module's terminal housing assembly.

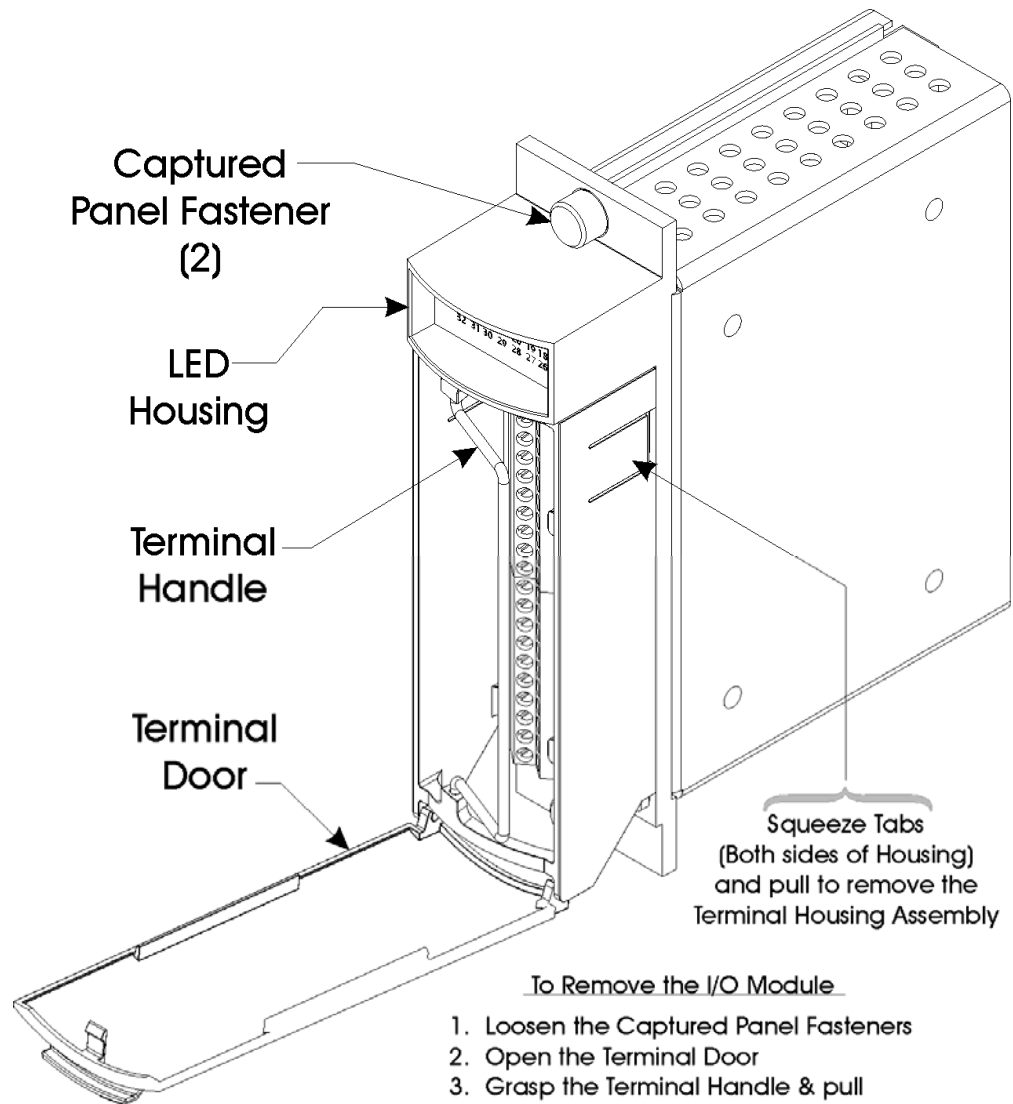



Figure 3-1. Terminal Housing Assembly Removal

7. Using a PC running ControlWave Designer and OpenBSI software, configure the ControlWave project running in the **host ControlWave controller** to reference the new I/O modules in the I/O rack, and download the revised ControlWave project into the host controller.

Note: This step is beyond the scope of this manual. Refer to the *ControlWave Designer Programmer's Handbook (D5125)* for further instructions.

 **Caution** The ControlWave I/O expansion rack supports “hot swapping” of I/O modules, but before any I/O modules can become operational, you must use ControlWave Designer to configure the ControlWave project in the host ControlWave process automation controller to accept the new I/O module, and then compile and download the revised application (project) into the host controller.

Do not install any modules in the housing until you have mounted and grounded the housing at the designated installation site.

To ensure safe use of this product, please review and follow the instructions in the following supplemental documentation:

- Supplement Guide - ControlWave Site Considerations for Equipment Installation, Grounding, and Wiring (S1400CW)
 - ESDS Manual – Care and Handling of PC Boards and ESD Sensitive Components (S14006)
-

 **WARNING** NEVER ATTEMPT “hot swapping” in a Class I, Division 2 hazardous location.

3.1 Module Placement

You can place I/O modules in the housing:

- 6-slot housing: supports up to four I/O modules in slots 3 through 6.
- 10 slot housing: supports up to eight I/O modules in slots 3 through 10.

Note: Interrupt driven I/O modules, such as the Universal Digital Input (UDI) **cannot** reside in slots 7 through 10 of the 10 slot housing.

Figure 3-2 shows slot assignments for an 8 I/O ControlWave I/O expansion rack.

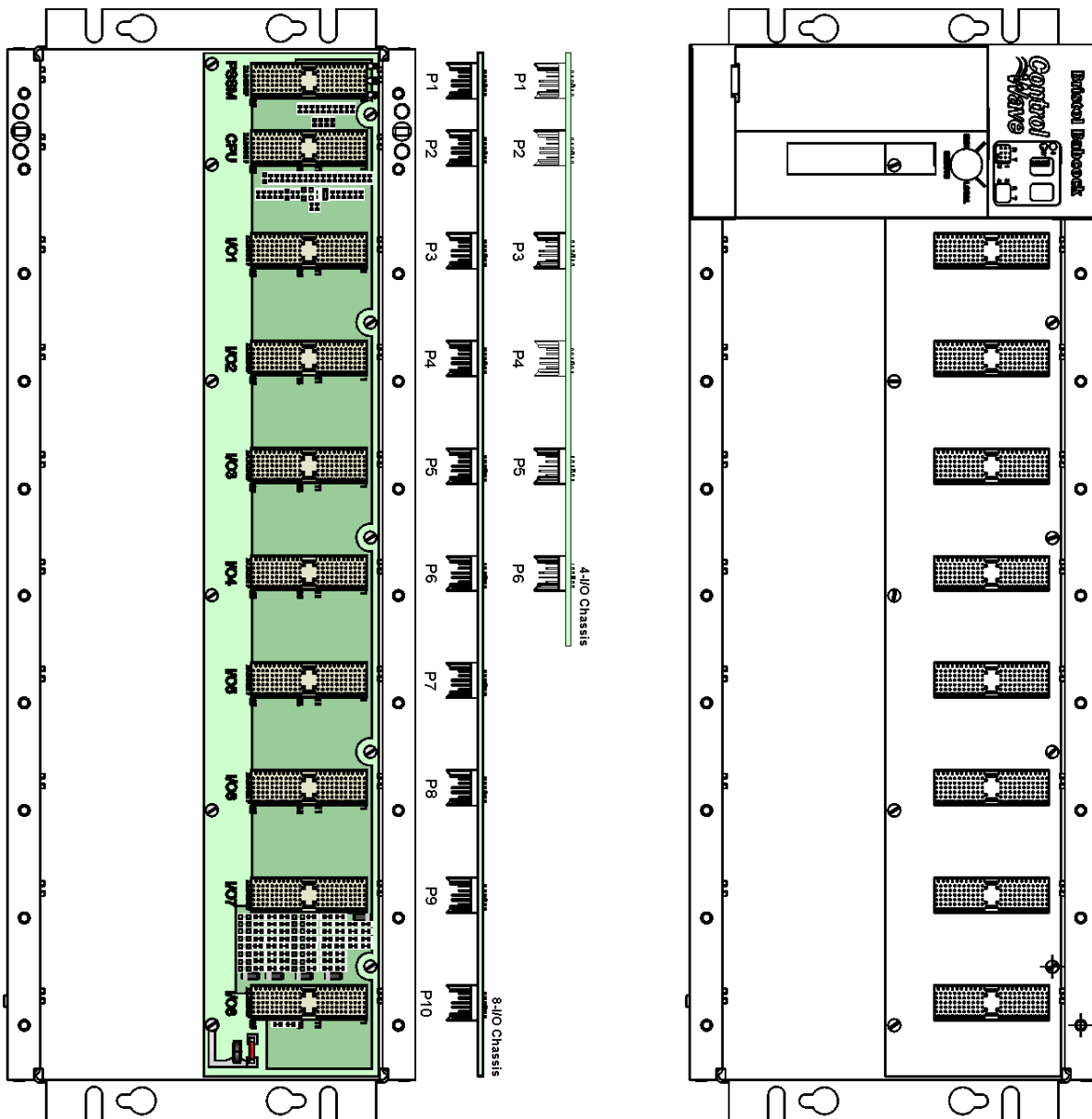

Figure 3-2. ControlWave Chassis Slot Assignments (with/without bezel shown)

3.2 Status LEDs

Most of the I/O modules include one or more light emitting diodes (LEDs) to provide diagnostic or status indications.

See *Chapter 5* for information on the different LEDs.

3.3 Wiring

With a few exceptions (noted in the module descriptions), I/O modules support either “local termination” (field wiring connected directly to the module’s removable terminal blocks) or “remote termination” (field

wiring connected to the remote headers under the module's cover and routed to a DIN-rail mounted terminal assembly and then to field devices).

ControlWave I/O modules use compression-type terminals that accommodate up to #14 AWG wire. Insert the wire's bared end (approx. ¼" max) into the clamp beneath the screw and secure the wire. To prevent shorts, ensure that no bare wire is exposed. If using standard wire, tin the bare end with solder to prevent flattening and improve conductivity. Allow some slack in the wires when making terminal connections. Slack makes the wires more manageable and helps minimize mechanical strain on the terminal blocks.

3.3.1 Local Termination

For I/O modules equipped with local terminal blocks, install the field wiring between the I/O module's removable terminal block connectors and field devices (see *Figure 3-3*). Use AWG 14 or smaller wire (consult with the field device manufacturer for recommendations). Leave some slack and plan for wire routing, identification, and maintenance. Route the bundled wires out through the bottom of the I/O module assembly between the terminal block and the terminal housing.

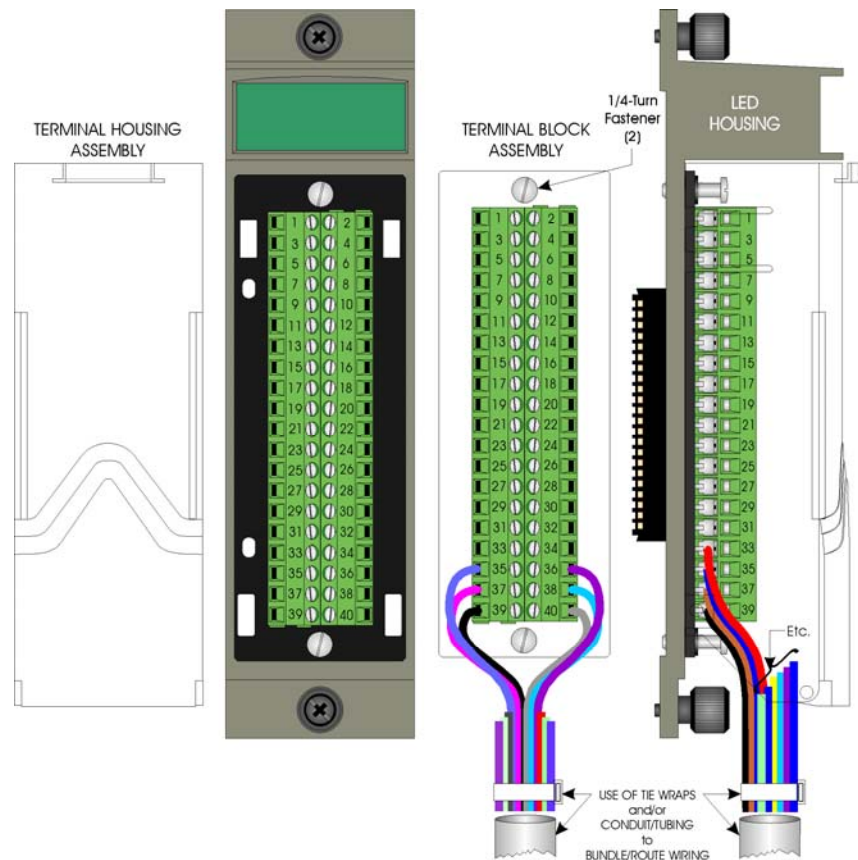

Figure 3-3. I/O Module (Local Termination) Wire Routing

3.3.2 Remote Termination

For I/O modules that support remote terminations, install cables between the module's remote headers and the remote DIN-rail mounted terminal block assemblies (see *Figure 3-4*). Install field wiring between the DIN-rail mounted terminal block assembly and field devices (see the wiring diagrams associated with each I/O module description).

Use AWG 14 or smaller wire (consult with the field device manufacturer for recommendations) for remote terminations. Leave some slack and plan for wire routing, identification, and maintenance. Route the cables running between the I/O module and the DIN-rail mounted terminal blocks out through the bottom of the I/O module between the header block and the terminal housing assembly.

To provide access to the header block's lower $\frac{1}{4}$ turn fastener use a tie wrap to secure cables associated with connectors P3 and P4 to the lower left side of the header block assembly. Use a second tie wrap to secure cables for connectors P1 and P2 to the lower right side of the header block assembly.

3.3.3 Shielding and Grounding

Use twisted-pair, shielded and insulated cable for I/O signal wiring to minimize signal errors caused by electromagnetic interference (EMI), radio frequency interference (RFI), and transients. When using shielded cable, ground all shields at only one point in the appropriate system. This prevents circulating ground current loops that can cause signal errors.

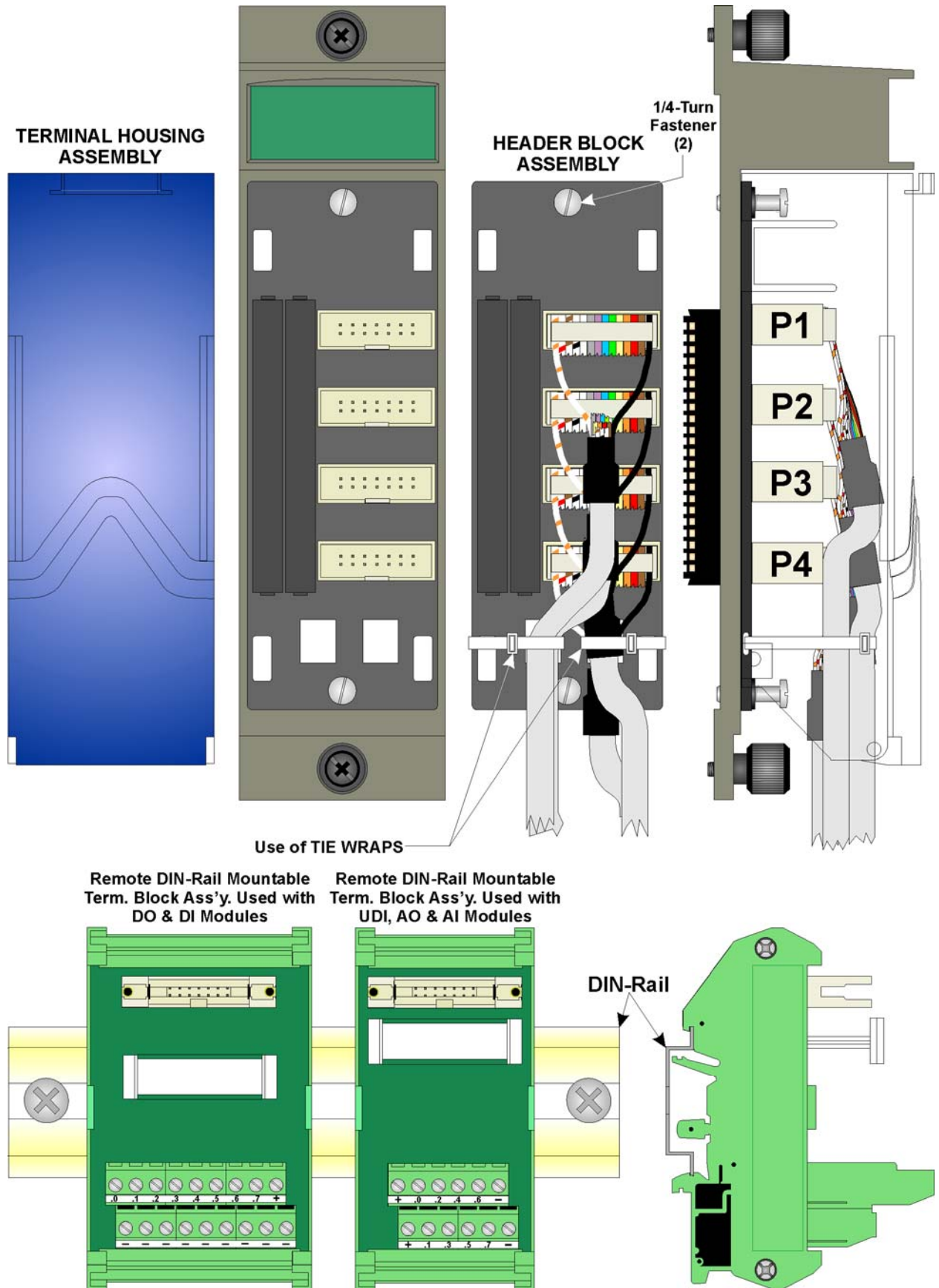

Figure 3-4. I/O Module (Remote Termination) Wire Routing

3.4 Digital Input (DI) Modules

DI modules provide 16 or 32 digital inputs. Using jumpers, you can individually configure each input as either externally sourced or internally powered using an internal +21 Vdc power supply (dry contacts).

Note: Early versions of ControlWave DI modules required you to specify either internal or external sourcing for all DIs when you ordered the module; now you can set this yourself using jumpers on a per DI basis.

Table 3-1 DI Module General Characteristics

Type	Number Supported	Characteristics
Digital Inputs (DI)	16 or 32	Each DI supports/ includes: <ul style="list-style-type: none"> ▪ Nominal input voltage of 24Vdc at 5 mA. ▪ Jumper to configure choice of either: externally sourced input - or -internally powered dry contact using internal +21 Vdc power supply. ▪ Nominal input current of 5 mA ▪ 30 ms input filtering ▪ Dedicated LED on module turns ON when DI is ON

A DI module consists of a digital input printed circuit board (PCB) with either a terminal block assembly (for local termination) or a header block assembly (for remote termination). Each DI module also includes an LED board, as well as I/O assembly and mounting hardware. The DI PCB connects to the backplane using a 110-pin connector.

Detailed Technical Specifications For detailed technical specifications, please see document CWPAC:DIO available on our website <http://www.emersonprocess.com/remote>.

Configurations DI modules (general part number **396357-XX-X**) come in several different configurations. See *Table 3-2* to see the variations.

Table 3-2 DI Module Configurations

Part Number	Number of DIs	Termination Connector
396357-01-6	32	Local
396357-02-4	16	Local
396357-11-3:	32	Remote
396357-12-1	16	Remote

Isolation Surge suppressors and optocouplers electrically isolate the DI field circuitry from the module's bus interface circuitry. Inputs configured

for use in dry contact applications contain a +21 Vdc isolated power supply powered through an output of the hot swap circuitry which receives power originating on the backplane.

Setting Jumpers You must set configuration jumpers for each DI. according to *Table 3-3*. For a 16DI module, use W1 through W16, for a 32DI module, use W1 through W32.

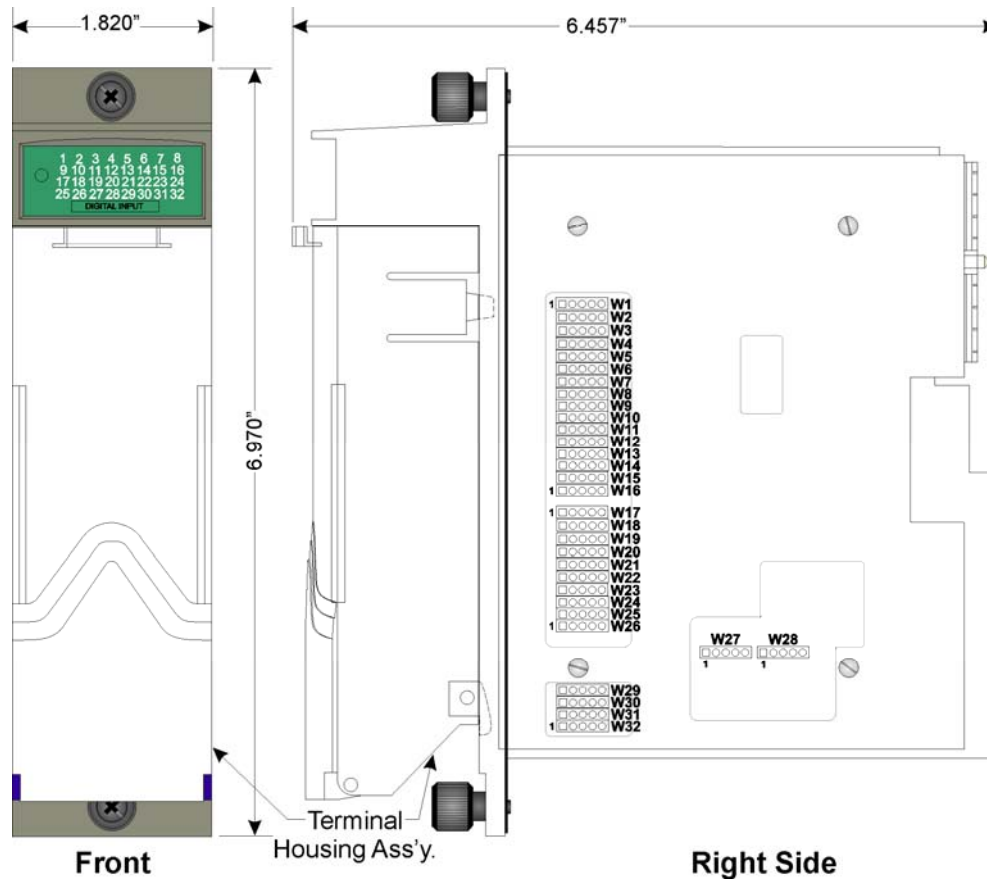

Figure 3-5. DI Module -Right Side View - Jumper Locations

Table 3-3. Jumper Assignments: DI Module

Jumper	Purpose	Description
W1	Configures DI1	Pins 2-3 & 4-5 installed = External Power DI Pins 1-2 & 3-4 installed = Internal Source DI
W2-W32	Configures DI2 through DI32 (respectively)	Same as W1

Wiring the Module *Figure 3-6* shows field wiring assignments associated with locally terminated DI modules; *Figure 3-9* shows field wiring assignments associated with remotely terminated DI modules. *Figure 3-10* shows an optional remote termination module with built-in discrete relay module that supports input from 120 Vac DIs. The special remote termination module (with built-in discrete relay module) interfaces with an externally sourced DI module.

**Terminal Block Assembly Assignments
for DI Operation**

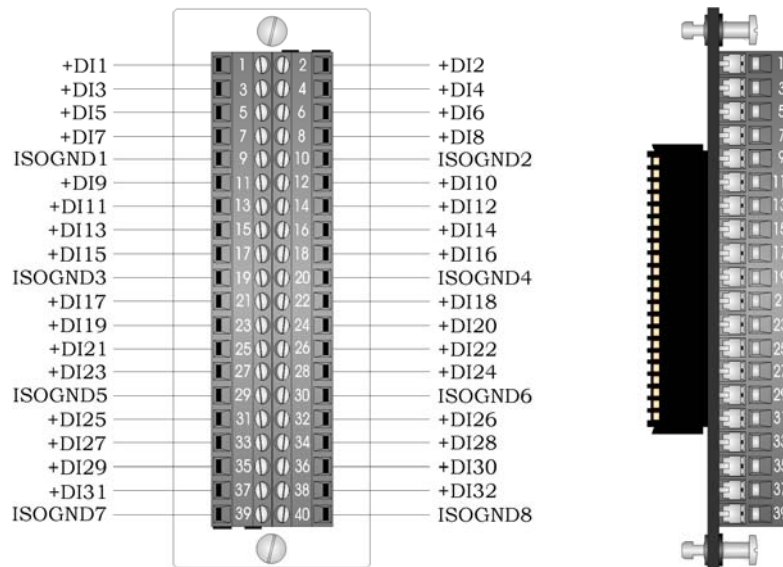

Figure 3-6. DI Module - Local Terminal Block Assembly Assignments

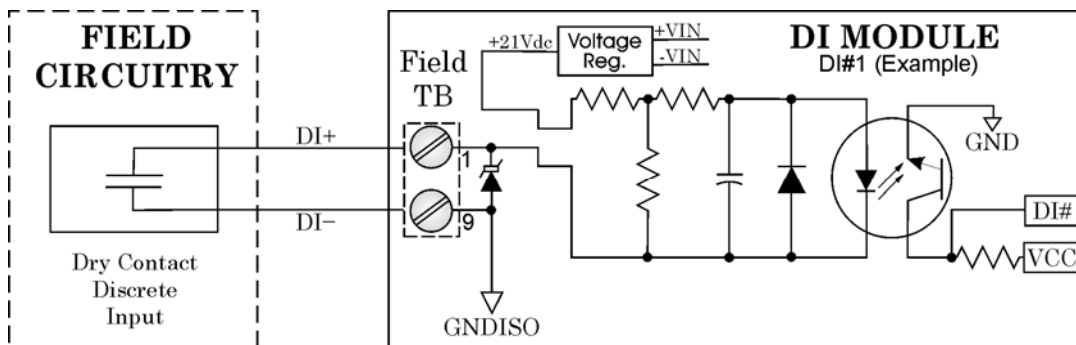

Figure 3-7. Internally Sourced DI Module - Wiring Diagram

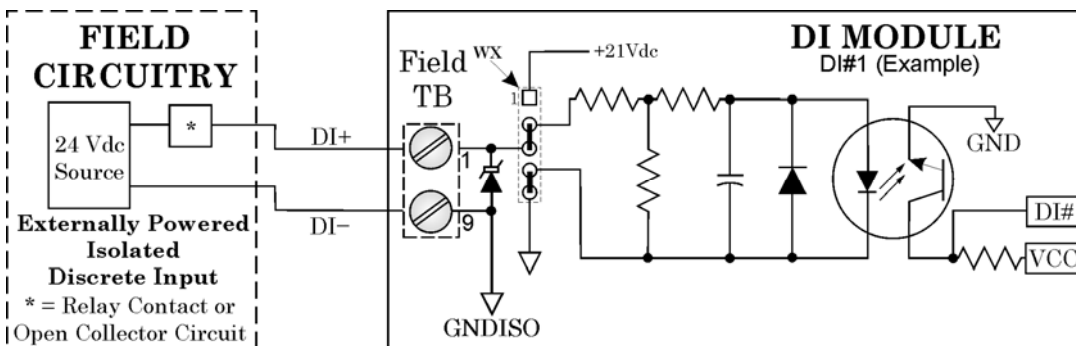
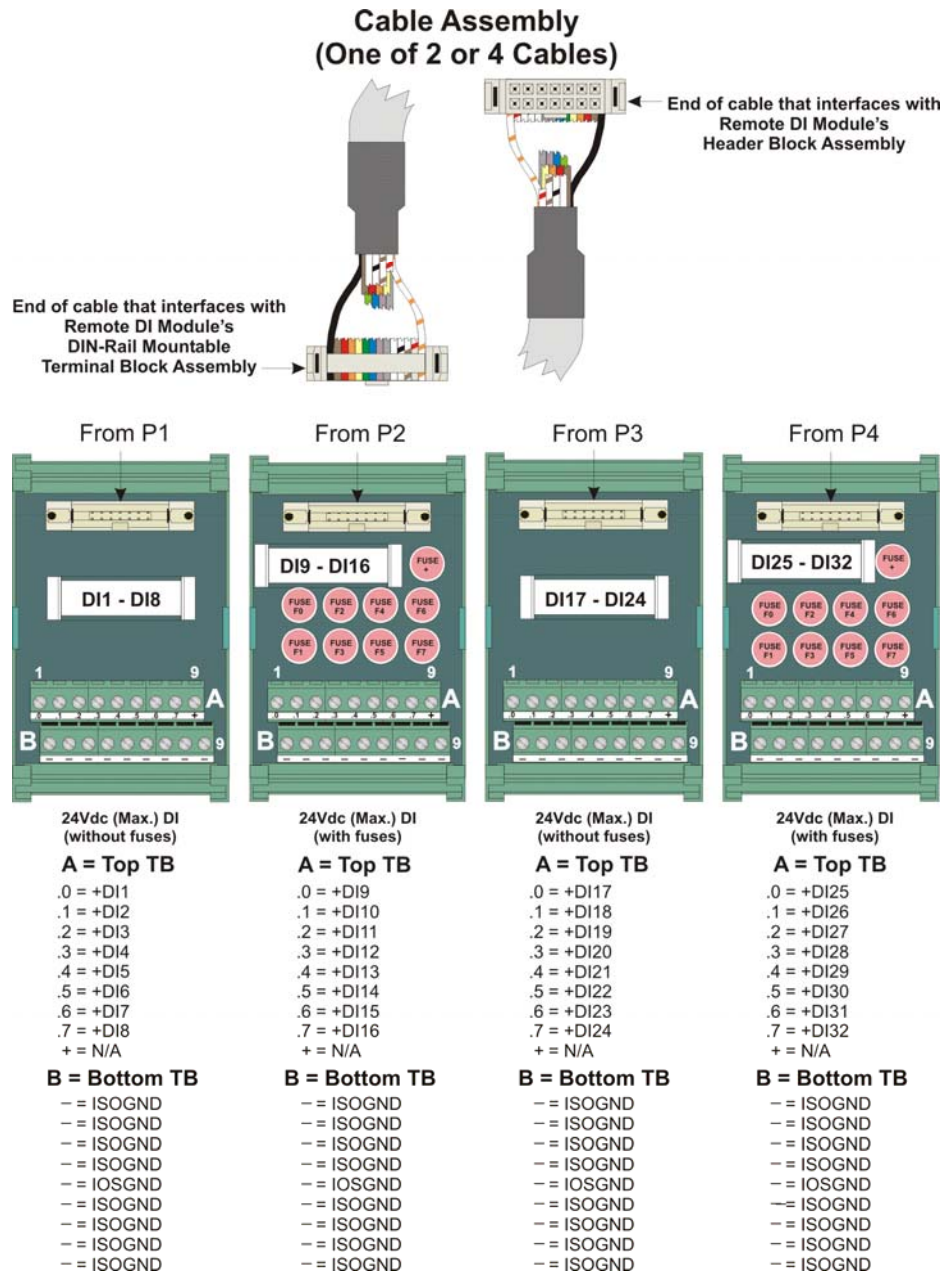

Figure 3-8. Externally Powered DI Module - Wiring Diagram



FUSES: F0 to F7: 1/8A, F+: 2A

Figure 3-9. Remote DIN-Rail Mountable Terminal Block Assembly Assignments

Software Configuration

To use data from any ControlWave DI module in the rack you must use ControlWave Designer's I/O Configurator to modify the ControlWave project in the host to add an **ER_DI32** board and then configure it. See the *ControlWave Designer Programmer's Handbook* (D5125) for more information. That same manual includes an *I/O Mapping* section that describes, for advanced users, the I/O map for this module.

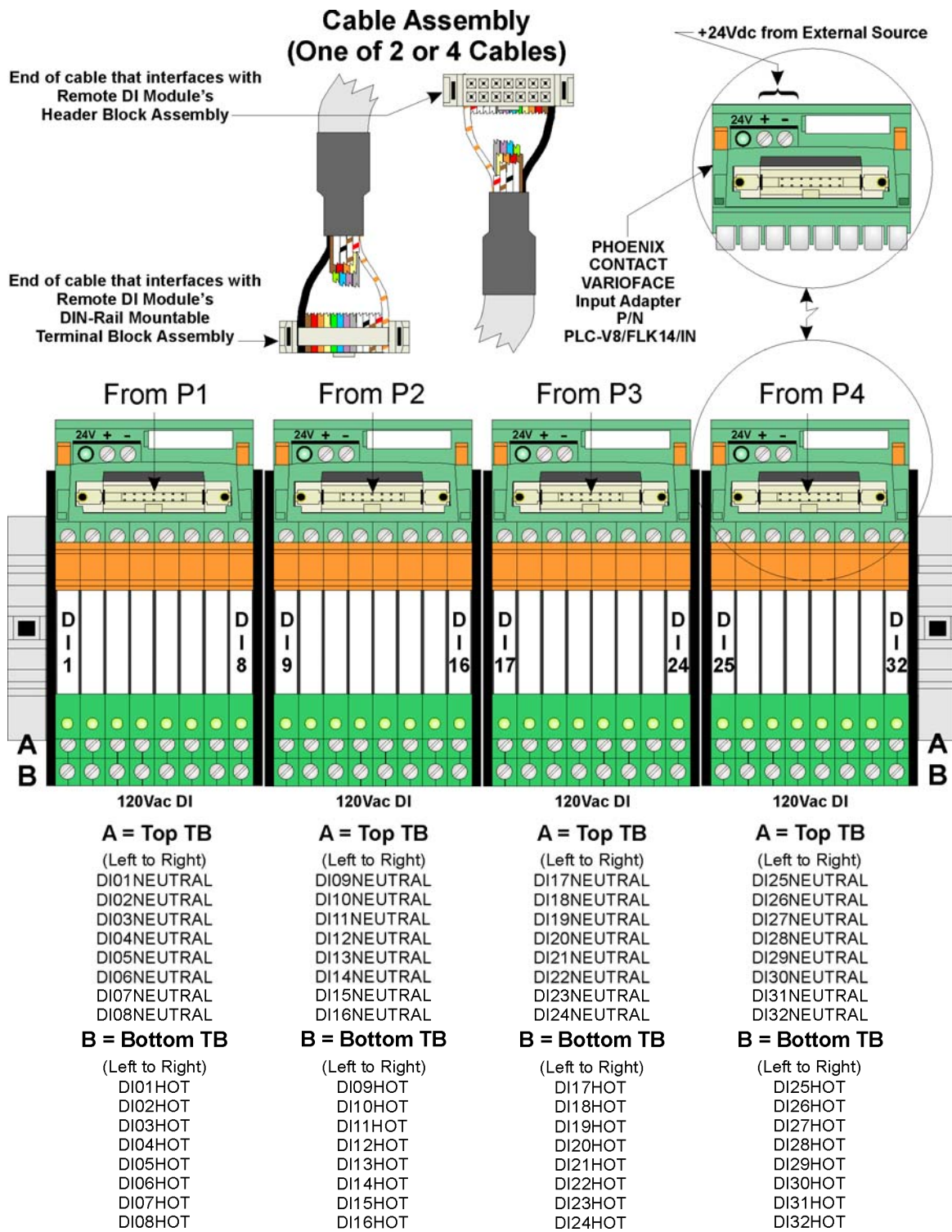

Figure 3-10. Remote DIN-Rail Mountable Terminal Block Assembly Assignments for Relay Isolated 120Vac DI Operation

3.5 Digital Output (DO) Modules

DO modules provide 32 or 16 DOs to control signaling functions.

DO modules consist of a DO PCB with either a terminal block assembly (for local termination) or a header block assembly (for remote termination). DO modules also include an LED board, a terminal housing assembly, as well as I/O assembly and mounting hardware.

Table 3-4 DO Module General Characteristics

Type	Number Supported	Characteristics
Digital Outputs (DO)	32 or 16	Each DO supports/ includes: <ul style="list-style-type: none"> ▪ Optically isolated open source MOSFET with surge suppression that is capable of handling 500mA at 31V. ▪ Maximum operating frequency of 20 Hz. ▪ Dedicated LED on module turns ON when DO is ON.

Detailed Technical Specifications

For detailed technical specifications, please see document CWPAC:DIO available on our website <http://www.emersonprocess.com/remote>.

Configurations

The DO module (general part number **396358-XX-X**) comes in several possible configurations, see *Table 3-5*:

Table 3-5. Isolated DO Module Configurations

Part Number	Number of DOs	Termination Connector	Notes
396358-01-2	32	Local	
396358-02-0	16	Local	
396358-11-0	32	Remote	
396358-12-8	16	Remote	
396358-20-9	16	Remote	DO with read-back

Jumper determines state of DOs on power-up

An on-board DO load register stores output data. Jumper JP4 determines the initial state of DOs on power-up. (NEED ARVIND OR FRED TO REVIEW THIS)

Table 3-6. DO State on Power-up

JP4 Jumper Position	Initial DO State on Power-Up
1-2	Clear register – all outputs set to OFF on power-up, regardless of application initial value setting.
2-3	Hold last output – on power-up, DO that was OFF at watchdog is OFF at power-up, DO that was ON at watchdog is ON at power-up.

Digital Output with Readback

Newer digital output modules with 16 outputs support read-back capability for use in redundant systems. A DO with read-back module

operating in online mode monitors the DO values of its standby counterpart in order to verify that standby DO values are consistent should a failover occur. Depending upon software configuration settings; a failover can be prevented if they are inconsistent. A standard DO module used in a redundant system does not perform this monitoring; therefore the potential exists to failover to a backup DO module with failed hardware. For critical processes, the redundant DO with read-back capability is recommended.

Use the same DO module type in any redundant pair; do not install a DO with read-back module in the primary rack and a standard DO module as its redundant counterpart in the backup rack, or vice versa.

See *Software Configuration* later in this section for details on setting up DO with readback.

Wiring the Module *Figure 3-11* shows field wiring assignments associated with a locally terminated DO module; *Figure 3-12* shows a wiring diagram for the DO. Field wiring assignments associated with remotely terminated DO modules. *Figure 3-13* shows field wiring assignments for a remotely terminated DO module. *Figure 3-14* shows a special remote termination module with built-in discrete relay modules.

**Terminal Block Assembly Assignments
for
DO Operation**

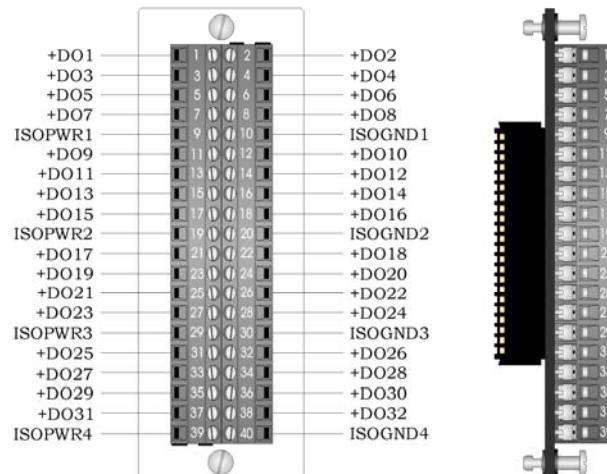
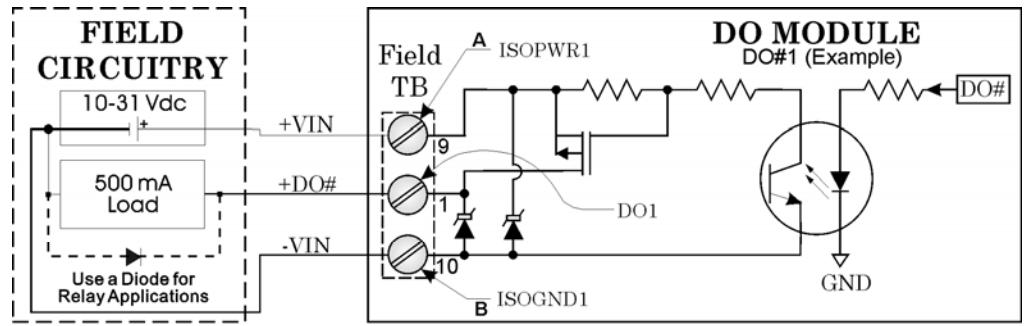

Figure 3-11. Local Terminal Block Assembly Assignments for Open Source Isolated DO Operation



A
B

Note: DO01 - DO08 use ISOPWR1 & ISOGND1
DO09 - DO16 use ISOPWR2 & ISOGND2
DO17 - DO24 use ISOPWR3 & ISOGND3
DO25 - DO32 use ISOPWR4 & ISOGND4

Figure 3-12. Open Source Isolated DO Module - Wiring Diagram

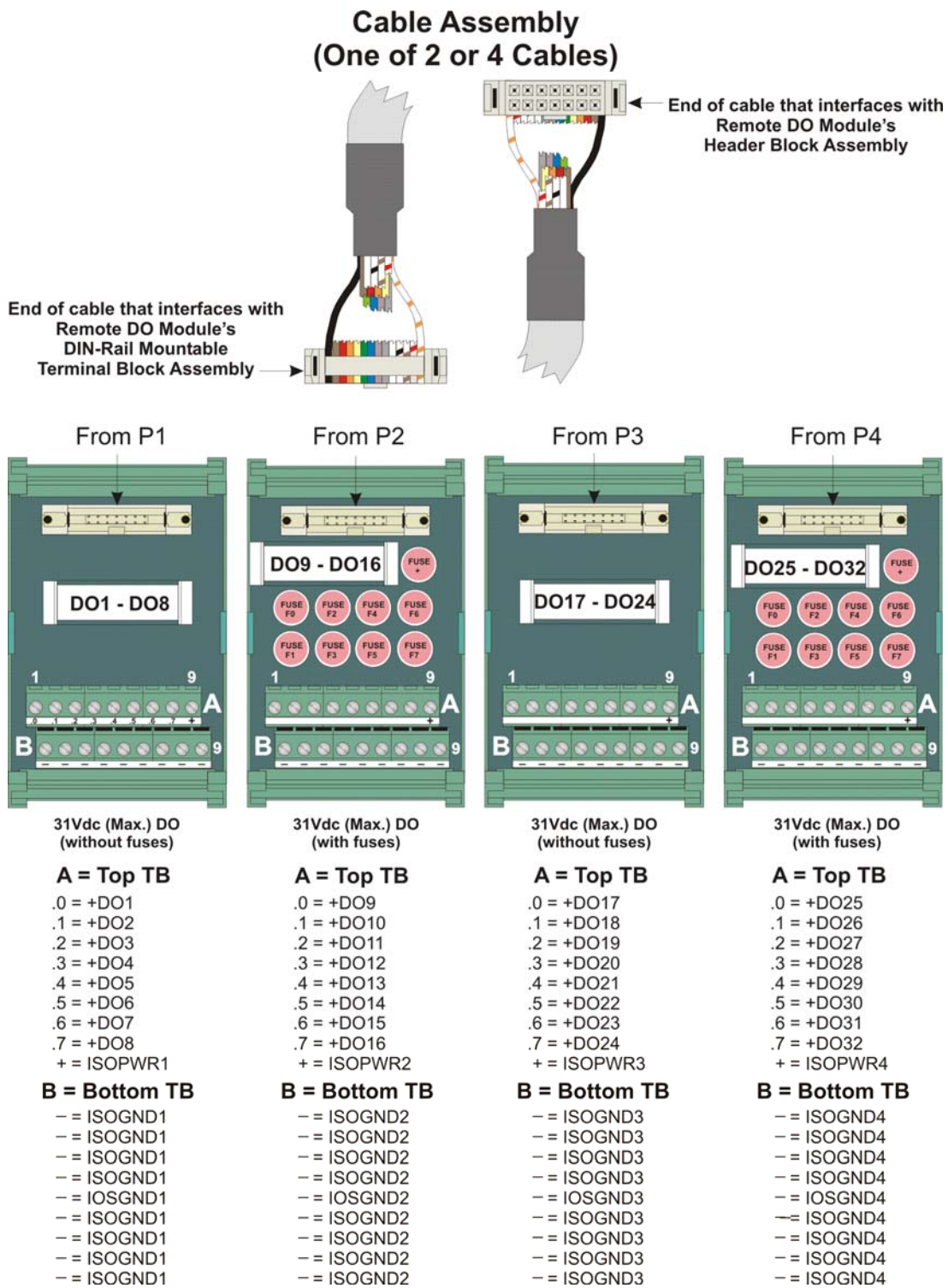

FUSES: F0 to F7: 1A, F+: 2A

Figure 3-13. Remote DIN-Rail Mountable Terminal Block Assembly Assignments for Open Source Isolated DO Operation

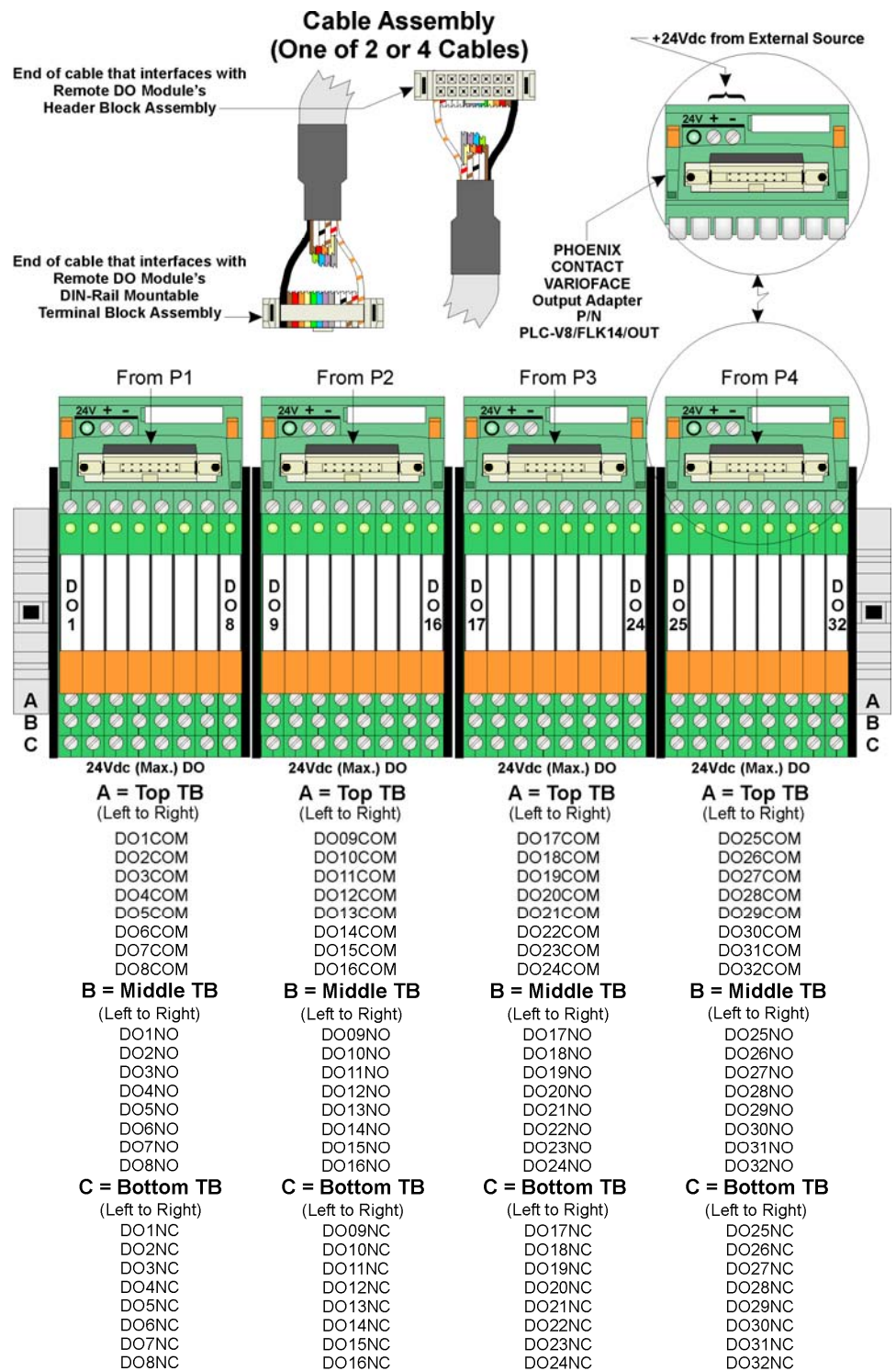

Figure 3-14. Remote DIN-Rail Mountable Terminal Block Assembly Assignments for Relay Isolated 24Vdc DO Operation

Software Configuration To use data from any ControlWave DO module in the rack you must use ControlWave Designer's I/O Configurator to modify the ControlWave project in the host controller to add an **ER_DO32** board and then configure it. See the *ControlWave Designer Programmer's Handbook* (D5125) for more information. That same manual includes an *I/O Mapping* section that describes, for advanced users, the I/O map for this module.

DO with Readback in a Redundant System

Variables in the ControlWave project govern how inconsistencies between the online DO module and the standby DO module are handled in redundant systems with DO readback. Information on configuring system variables is included in the *ControlWave Designer Programmer's Handbook* (D5125).

If there is a discrepancy between the value of the online and standby DOs, the system sets a status variable mapped by the `_ER_STAT` virtual status board to TRUE. By default, the name of the variable follows one of two possible formats.

`ERSTAT_n_RDN_IO_x_ERR`

`ERST_n_RDN_IO_x_ERR`

where *n* is the I/O slot number of the virtual `_ER_STAT` board, and *x* is the I/O slot number of the digital output module that has a failure. See the *I/O Configurator* and *I/O Mapping* sections of the *ControlWave Designer Programmer's Handbook* (D5125) for more information. You can optionally rename these variables.

You should configure these variables as alarms so you receive notification of a failure of the backup DO module. See the ControlWave Designer online help for information on alarm configuration.

When a read-back failure occurs, the FAIL LED remains RED until the unit reboots, either through a sideload, forced redundant switchover, or power-down and restart, or you remove and replace the board (hot card replacement). Each of these operations momentarily turns the FAIL LED to GREEN (and the associated `_ERR` error variable to FALSE) until a new readback failure occurs, which changes the LED back to RED, and the associated `_ERR` error variable back to TRUE.

Another variable which you must map from the `_ER_STAT` virtual status board determines whether a failure of the standby DO (as indicated by the LED and associated `_ERR` error variable) should only be treated as a warning condition, which would still allow a failover to occur, or as an error which would prevent a failover to the standby. By default, this variable is named either `ERSTAT_RDN_IOERR_WARN` (or `ERST_RDN_IOERR_WARN`). You can change the default names as needed.

When you set this variable to FALSE, the system treats a DO readback

failure in the associated device as an error; failover is inhibited. When you set this variable to TRUE, the system treats a DO readback failure in the associated device as a warning that does not prevent a failover, and the only reporting is via the `_RDN_IO_x_ERR` variables and LEDs discussed, above.

Note: In the I/O Configurator, you must associate these boards with a cyclic task, and the task must not run faster than 10 milliseconds.

3.6 Analog Input (AI) Modules

AI modules support either 16 or eight 4–20 mA or 1–5 Vdc analog inputs.

AI modules consist of an AI PCB with either a terminal block assembly (for local termination) or a header block assembly (for remote termination). AI modules also include an LED board, a terminal housing assembly, as well as I/O assembly and mounting hardware.

Table 3-7 Analog Input (AI) Module General Characteristics

Type	Number Supported	Characteristics
Analog Inputs (AI)	16 or 8	<p>Each AI supports:</p> <ul style="list-style-type: none"> ▪ Either 4–20mA internally sourced input or 1–5Vdc isolated input operation. Choice for whether the module supports 4-20mA or 1-5Vdc is set at the factory. ▪ 1-5Vdc AIs have a common mode range of 31Vdc. ▪ 4-20mA inputs reference –V_{Fxx} of the module. ▪ Analog input circuitry isolated from bus interface. ▪ Surge suppression and signal conditioning.

Cable Shields Connect cable shields associated with AI wiring to the ControlWave housing ground. Multiple shield terminations require that you supply a copper ground bus and connect it to the housing's ground lug (using up to a #4 AWG wire size).

This ground bus must accommodate a connection to a known good earth ground (in lieu of a direct connection from the ground lug) and to all AI cable shields. Shield wires should use an appropriate terminal lug. Secure them to the copper bus using industry rugged hardware (screw/bolt, lock washer, and nuts).

Detailed Technical Specifications For detailed technical specifications, please see document CWPAC:AIO available on our website <http://www.emersonprocess.com/remote>.

Configurations The AI module (general part number **396352-XX-X**) has the following configurations:

Table 3-8. Analog Input Module Configurations

Part Number	Number of AIs	Termination Connector	Notes
396352-01-4	16	Local	4-20 mA
396352-03-0	8	Local	4-20 mA
396352-11-1	16	Remote	4-20 mA
396352-13-8	8	Remote	4-20 mA
396352-12-0	16	Remote	1-5 Vdc

Wiring the Module Figure 3-18 shows terminal assignments for a locally terminated AI module; Figure 3-19 and Figure 3-20 show terminal assignments for a 4-20mA and a 1-5Vdc remotely terminated AI, respectively.

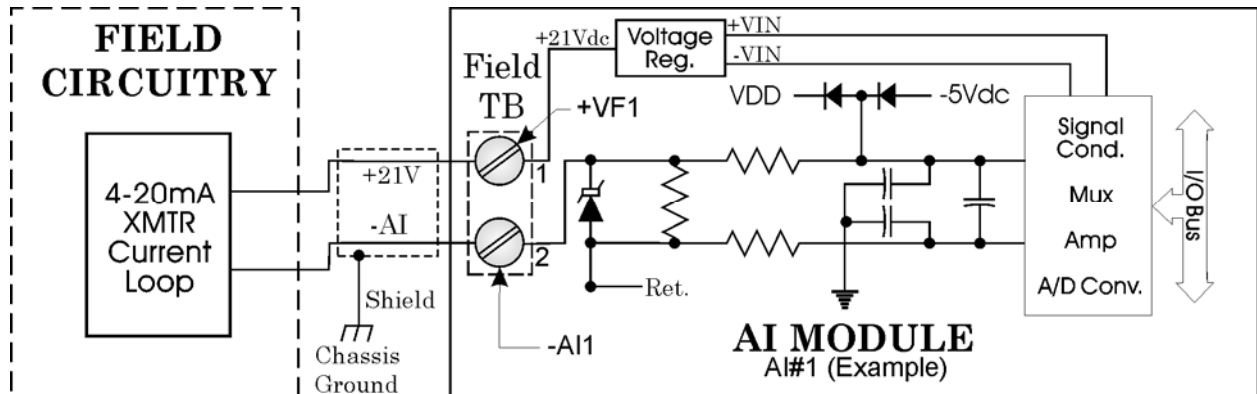

Figure 3-15. Internally Sourced 4-20mA Current Loop AI - Wiring Diagram

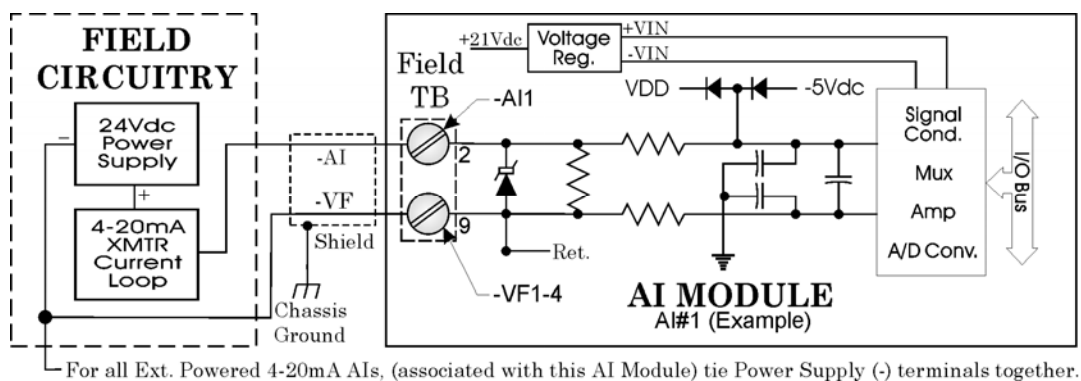

Figure 3-16. Externally Powered 4-20mA Current Loop AI - Wiring Diagram

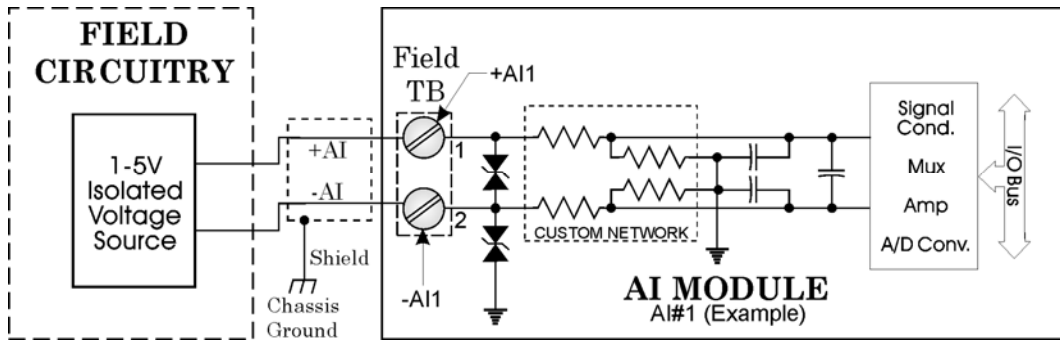

Figure 3-17. Externally Powered Isolated 1-5 Volt AI - Wiring Diagram

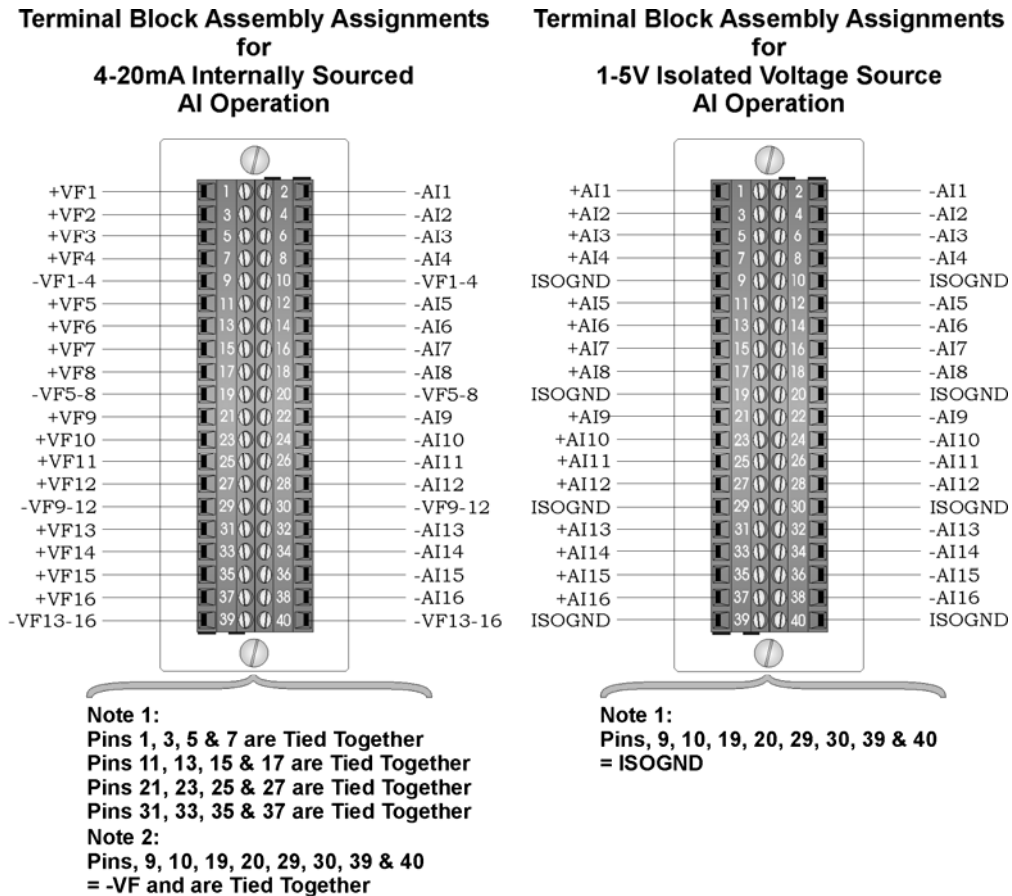

Figure 3-18. Local AI Module Terminal Blocks Assembly Assignments

Software Configuration To use data from any ControlWave AI module in the rack you must use ControlWave Designer’s I/O Configurator to modify the ControlWave project in the host controller to add an **ER_AI16** board and then configure it. See the *ControlWave Designer Programmer’s Handbook* (D5125) for more information. That same manual includes an *I/O Mapping* section that describes, for advanced users, the I/O map for this module.

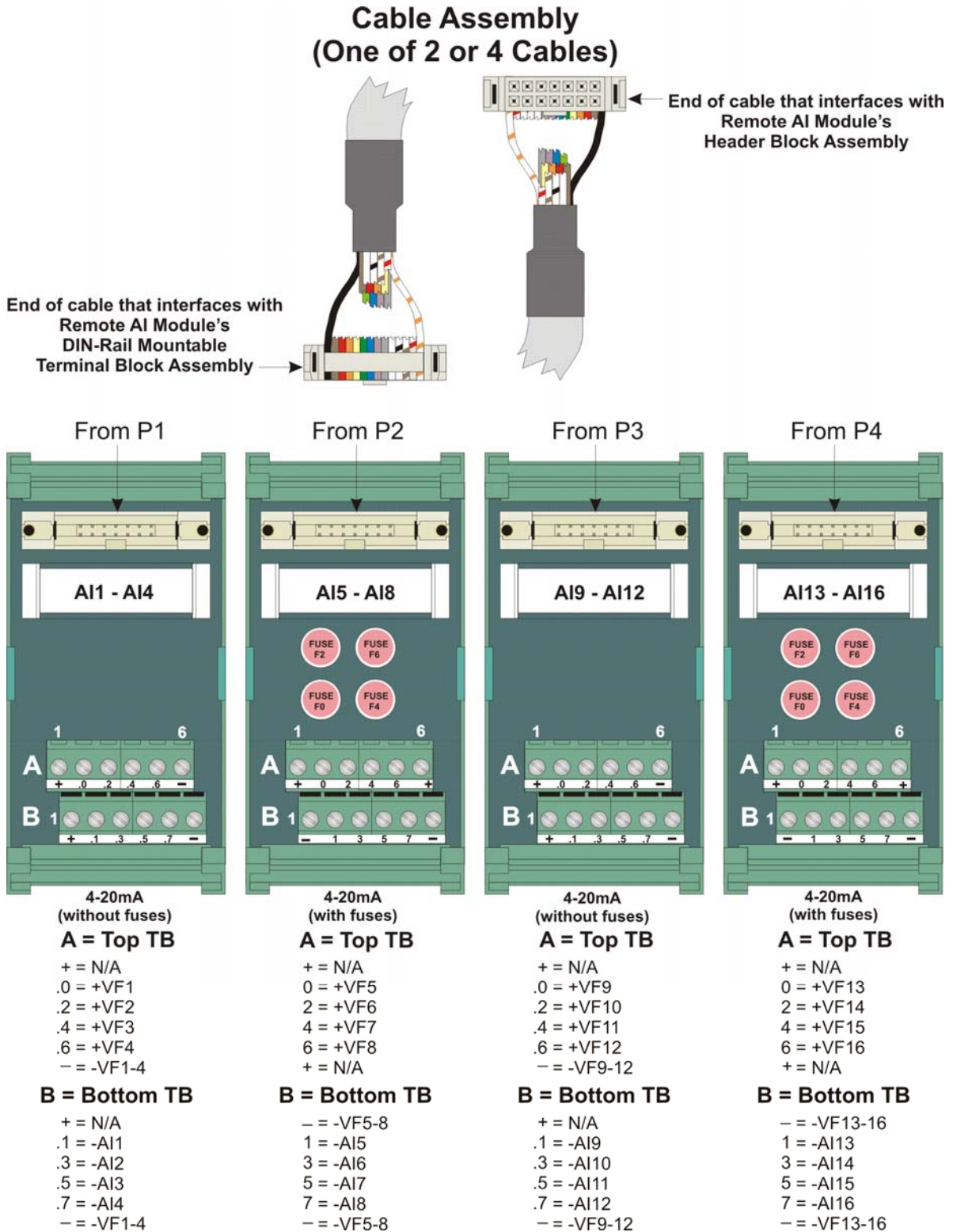
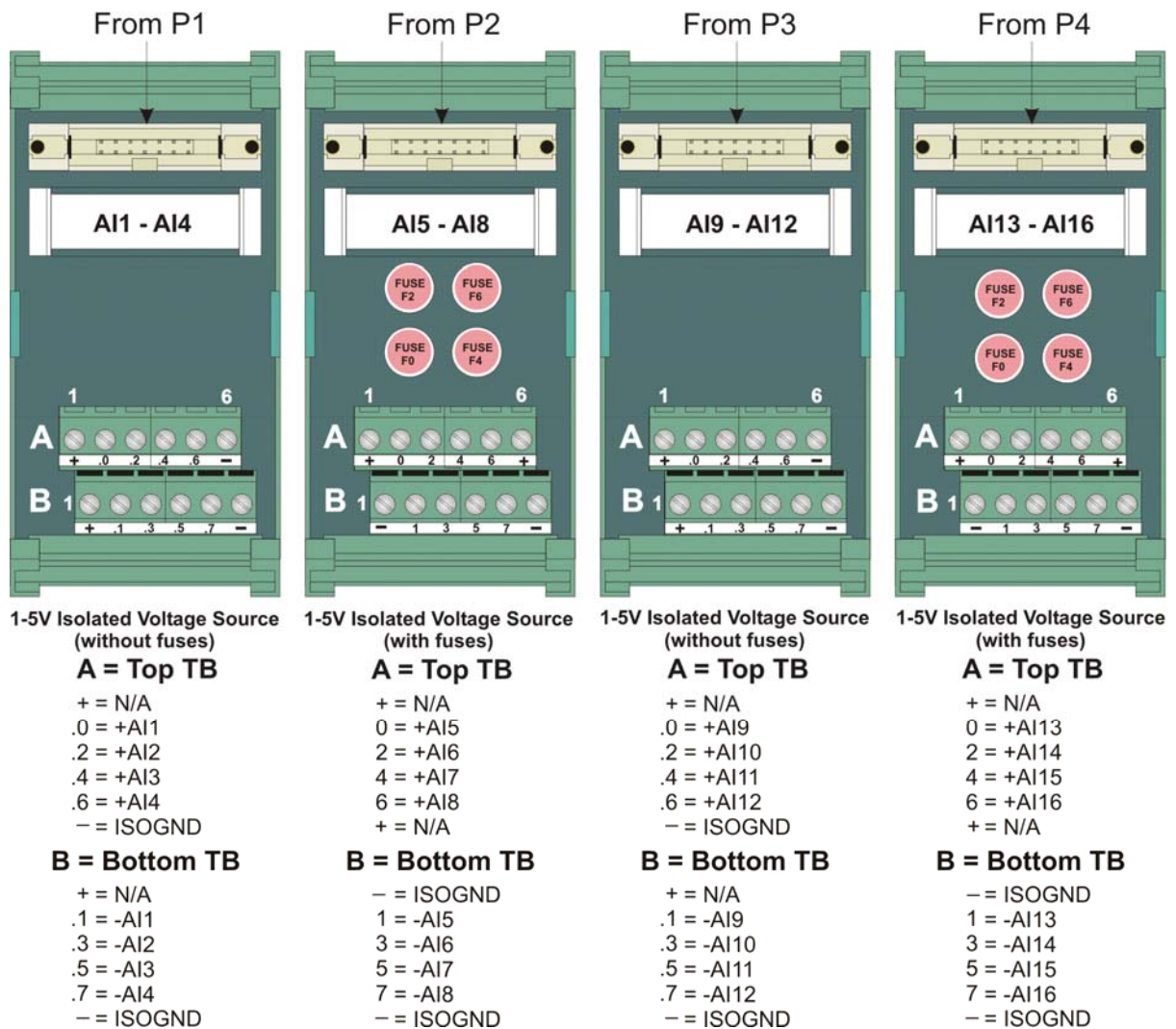
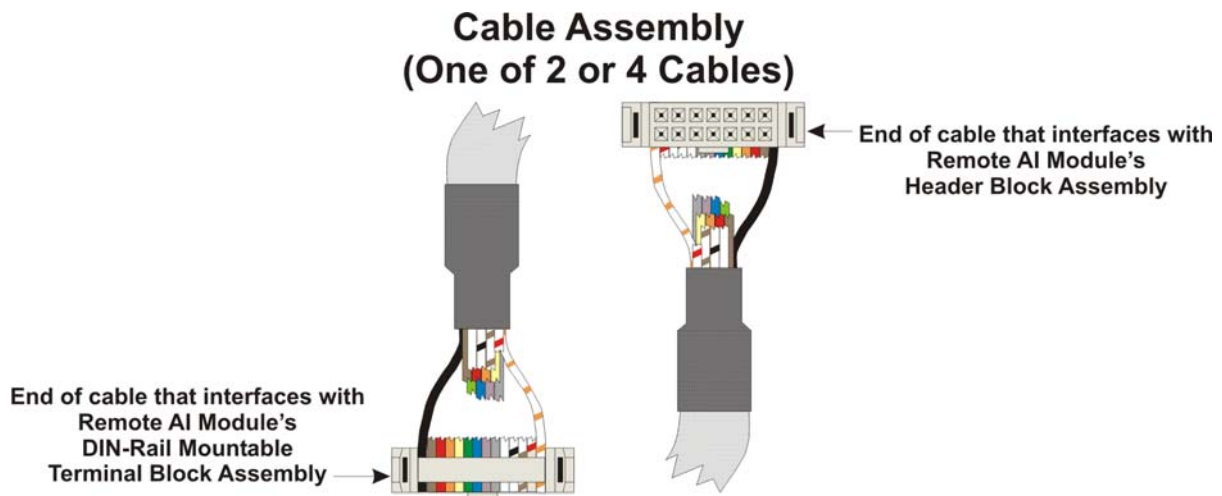

Figure 3-19. Remote DIN-Rail Mountable Terminal Block Assembly Assignments for 4-20 mA AI Operation



FUSES: F0, F2, F4, F6: 1/8A

Figure 3-20. Remote DIN-Rail Mountable Terminal Block Assembly Assignments for 1-5V AI Operation

3.7 Analog Output (AO) Modules

AO modules support eight 4–20 mA analog outputs. AO modules consist of an AO PCB (with a daughter board when configured for read-back) an LED board, a terminal housing assembly, as well as I/O assembly and mounting hardware.

Table 3-9. Analog Output (AO) Module General Characteristics

Type	Number Supported	Characteristics
Analog Outputs (AO)	8	Each AO supports: <ul style="list-style-type: none"> ▪ 4–20mA output with a maximum external load of 650 ohms. ▪ Analog output circuitry isolated from bus interface ▪ Surge suppression

Analog Output with Read-back

Analog output modules with eight outputs are available in two versions – standard AO, or AO with read-back capability for use in redundant systems. Both versions may be used in redundant systems; however, they operate differently.

An AO with read-back module operating in online mode monitors the AO values of its standby counterpart in order to verify that standby AO values are consistent should a failover occur. Depending upon software configuration settings; a failover can be prevented if they are inconsistent. A standard AO module used in a redundant system does not perform this monitoring; therefore the potential exists to failover to a backup AO module with failed hardware. For critical processes, the redundant AO with read-back capability is recommended.

Use the same AO module type in any redundant pair – i.e. do not install an AO with read-back module in the primary rack and a standard AO module as its redundant counterpart in the backup rack, or vice versa.

See *Software Configuration* later in this section for details on setting up AO with readback.

Detailed Technical Specifications

For detailed technical specifications, please see document CWPAC:AIO available on our website <http://www.emersonprocess.com/remote>.

Configurations

The isolated AO module (general part number **396353-XX-X**) has the following configurations:

Table 3-10. Analog Output Module Configurations

Part Number	Number of AOs	Termination Connector	Notes
396353-01-0	8	local	4-20mA
396353-11-8	8	remote	4-20mA
396353-20-7	8	remote	4-20mA AO Readback on this module

Wiring the Module Figure 3-21 shows field wiring assignments for a locally terminated AO module. Figure 3-22 shows field wiring assignments for a remotely terminated AO module.

Terminal Block Assembly Assignments for AO Operation

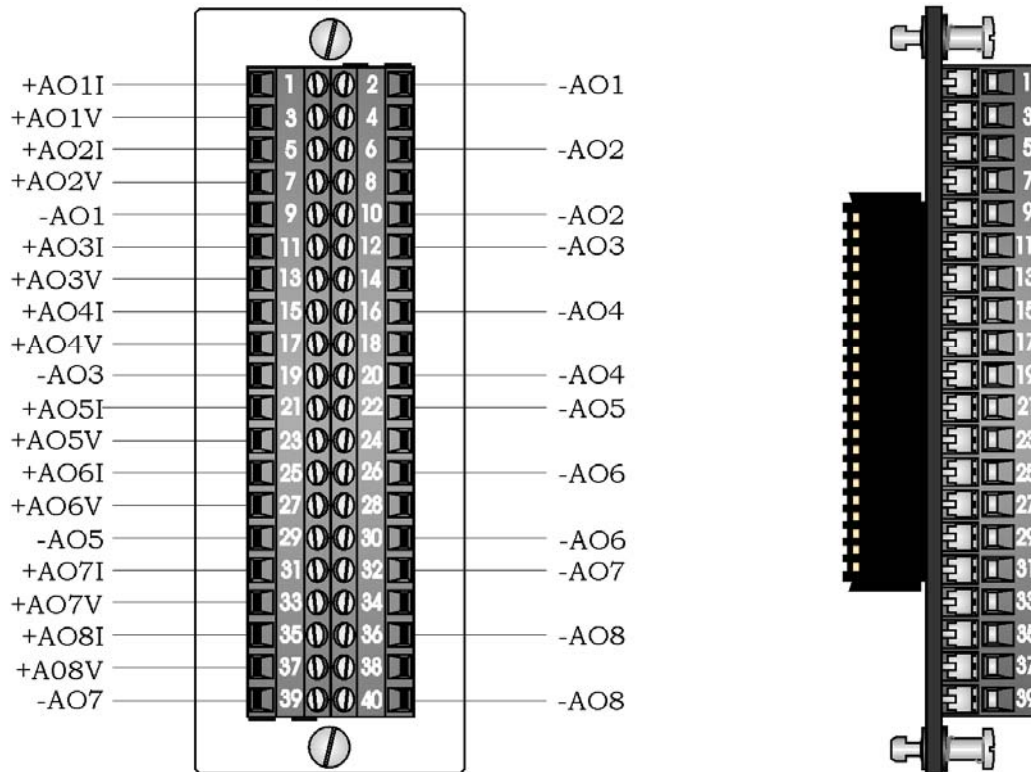
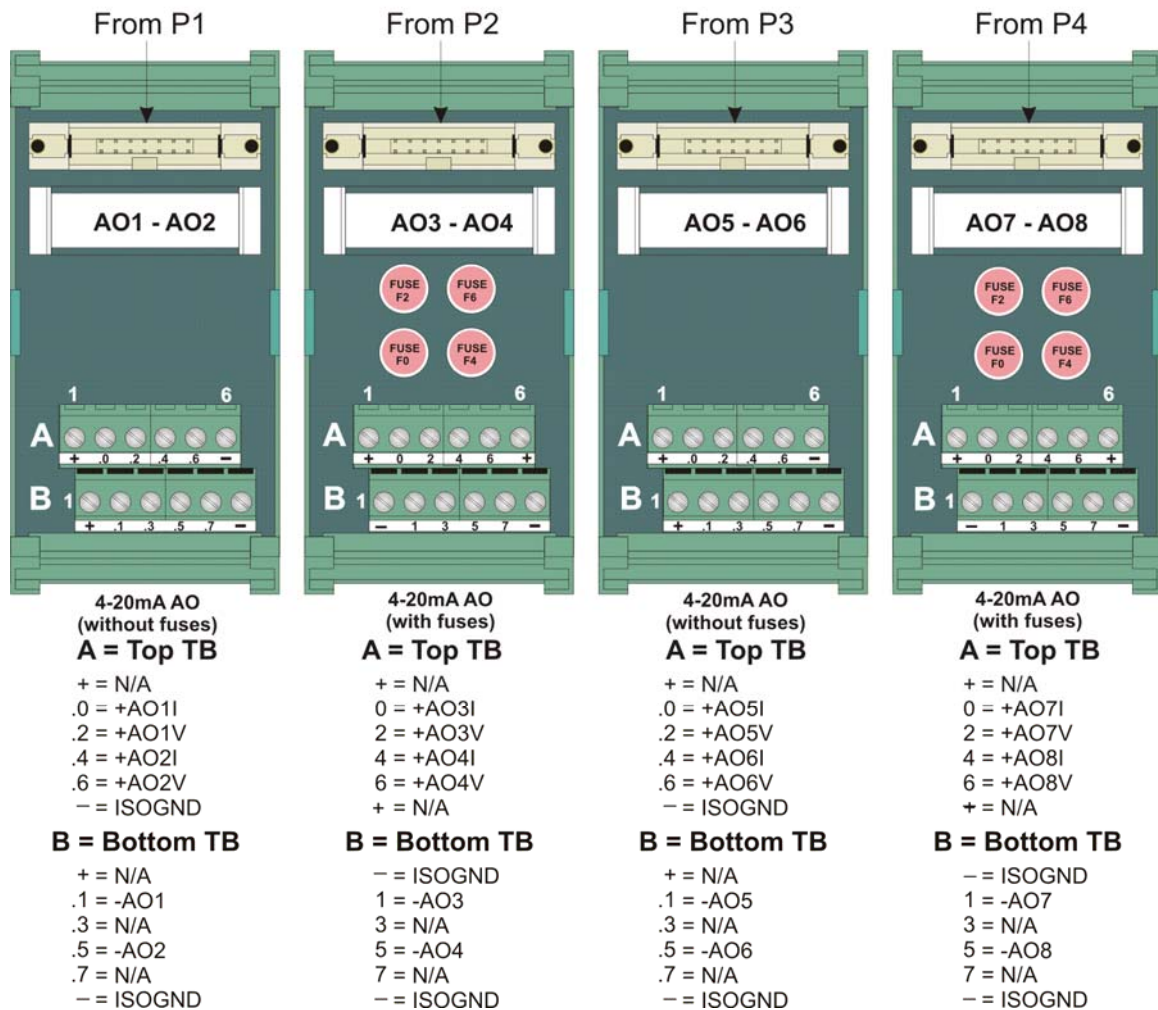
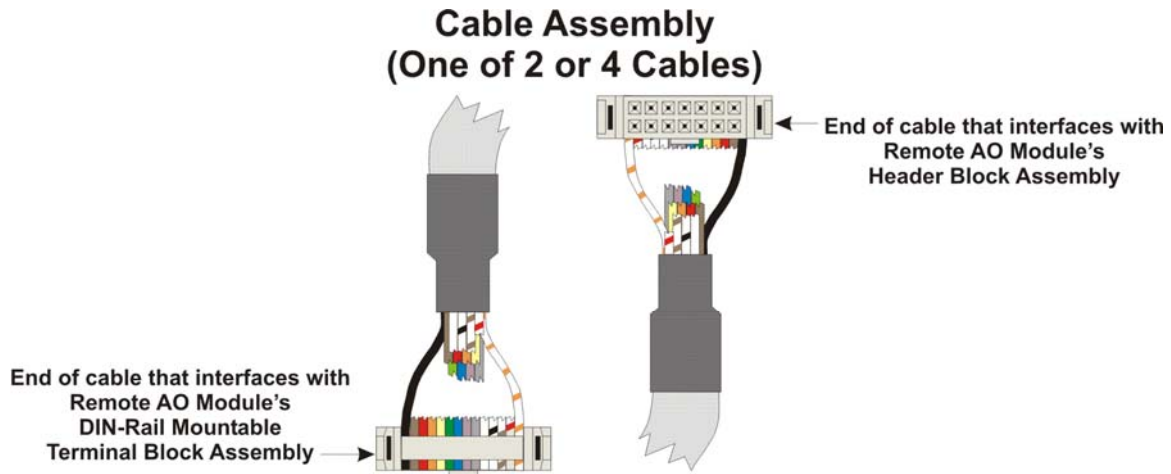

Figure 3-21. Local AO Module Terminal Blocks Assembly Assignments



FUSES: F0, F2, F4, F6: 1/8A

Figure 3-22. Remote DIN-Rail Mountable Terminal Block Assembly Assignments for AO 4-20mA Operation

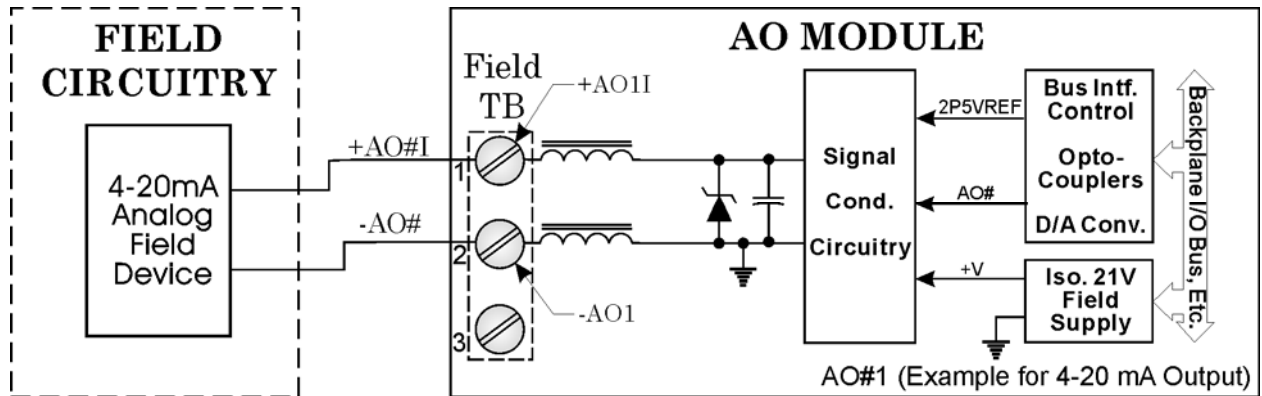

Figure 3-23. 4-20mA Current Loop AO - Wiring Diagrams

Software Configuration To use data from any ControlWave AO module in the rack you must use ControlWave Designer's I/O Configurator to modify the ControlWave project in the host controller to add an **ER_AO8** board and then configure it. See the *ControlWave Designer Programmer's Handbook* (D5125) for more information. That same manual includes an *I/O Mapping* section that describes, for advanced users, the I/O map for this module.

AO with Readback in a Redundant System

Variables in the ControlWave project govern how inconsistencies between the online AO module and the standby AO module are handled in redundant systems with AO readback. Information on configuring system variables is included in the *ControlWave Designer Programmer's Handbook* (D5125).

If there is a difference of more than 0.5% (of span) between the value of the online and standby AO values, a variable mapped by the `_ER_STAT` virtual status board will be set TRUE. By default, the name of the variable follows one of two possible formats.

`ERSTAT_n_RDN_IO_x_ERR`

`ERST_n_RDN_IO_x_ERR`

where *n* is the I/O slot number of the virtual `ER_STAT` board, and *x* is the I/O slot number of the analog output module. See the *I/O Configurator* and *I/O Mapping* sections of the *ControlWave Designer Programmer's Handbook* (D5125) for more information. You can optionally rename these variables.

You should configure these variables as alarms so you receive notification of a failure of the backup AO module. See the ControlWave Designer online help for information on alarm configuration.

When a read-back failure occurs, the FAIL LED remains RED until the

unit is rebooted, either through a sideload, forced redundant switchover, or power-down and restart, or you remove and replace the board (hot card replacement). Each of these operations momentarily turns the FAIL LED to GREEN (and the associated `_ERR` error variable to FALSE) until a new readback failure occurs, which will change the LED back to RED, and the associated `_ERR` error variable back to TRUE.

Another variable you must have mapped from the `_ER_STAT` virtual status board named either `ERSTAT_RDN_IOERR_WARN` (or `ERST_RDN_IOERR_WARN`) determines whether a failure of the standby AO (as indicated by the LED and associated `_ERR` error variable) should only be treated as a warning condition, which would still allow a failover to occur, or as an error which would prevent a failover to the standby. **Note:** Those are the default names; you can change them as needed.

When you set this variable to FALSE, an AO readback failure in the associated device is treated as an error; failover is inhibited. When you set this variable to TRUE, an AO readback failure in the associated device is treated as a warning that does not prevent a failover, and the only reporting is via the `_ERR` variables and LEDs discussed, above.

Note: In the I/O Configurator, you must associate these boards with a cyclic task, and the task must not run faster than 10 milliseconds.

3.8 Universal Digital Input (UDI) Modules

Universal Digital Input (UDI) modules include six inputs which you can individually configure as high speed counters or polled inputs.

UDI modules consist of a UDI PCB, either a terminal board assembly for local termination or a header block assembly for remote termination, a terminal housing assembly, an LED board, as well as I/O assembly and mounting hardware.

Note: Because UDI modules are interrupt driven, you can only install them in the first four I/O slots.

Table 3-11. UDI Module General Characteristics

Type	Number Supported	Characteristics
Universal Digital Inputs (UDI)	6	<p>Each UDI supports/includes:</p> <ul style="list-style-type: none"> ▪ Field input can be a driven signal, an open collector output, or a relay contact. Inputs handle 24V ▪ Jumper to configure point for debounce enable or debounce disable. ▪ Software configures point as a polled input with a 30 millisecond filter or as a 16-bit high speed counter (totalizer) with a 20 microsecond filter. When used as a totalizer, the maximum totalized count before rollover is 65,535. The count is not resettable through software. ▪ Maximum input frequency of 10 KHz with a nominal input current of 5mA. ▪ 16 bit counter. ▪ Signal conditioning circuitry and bandwidth limiting circuitry. Software selectable delays for signal conditioning. ▪ Each input is optically isolated from the field device. ▪ Each input has an electrical isolation of 500Vdc to chassis and 1500Vdc to system logic. ▪ Surge protection. Protection from a 31dc transorb (across input and to field common) that meets ANSI/IEEE standard C37.90-1978.

Additional Technical Specifications

For additional technical specifications, please see document CWPAC:UDI available on our website <http://www.emersonprocess.com/remote>.

Configurations The UDI module (general part number **396362-XX-X**) has the following configurations:

Table 3-12. UDI Module Configurations

Part Number	Number of UDIs	Termination Connector
396362-02-8	6	local
396362-12-5	6	remote

Setting Jumpers Each input has a jumper to enable/disable debounce. Enabling debounce activates filters that reduce spurious pulses caused by relay contact bounce. *Figure 3-24* shows the location of jumpers on the module.

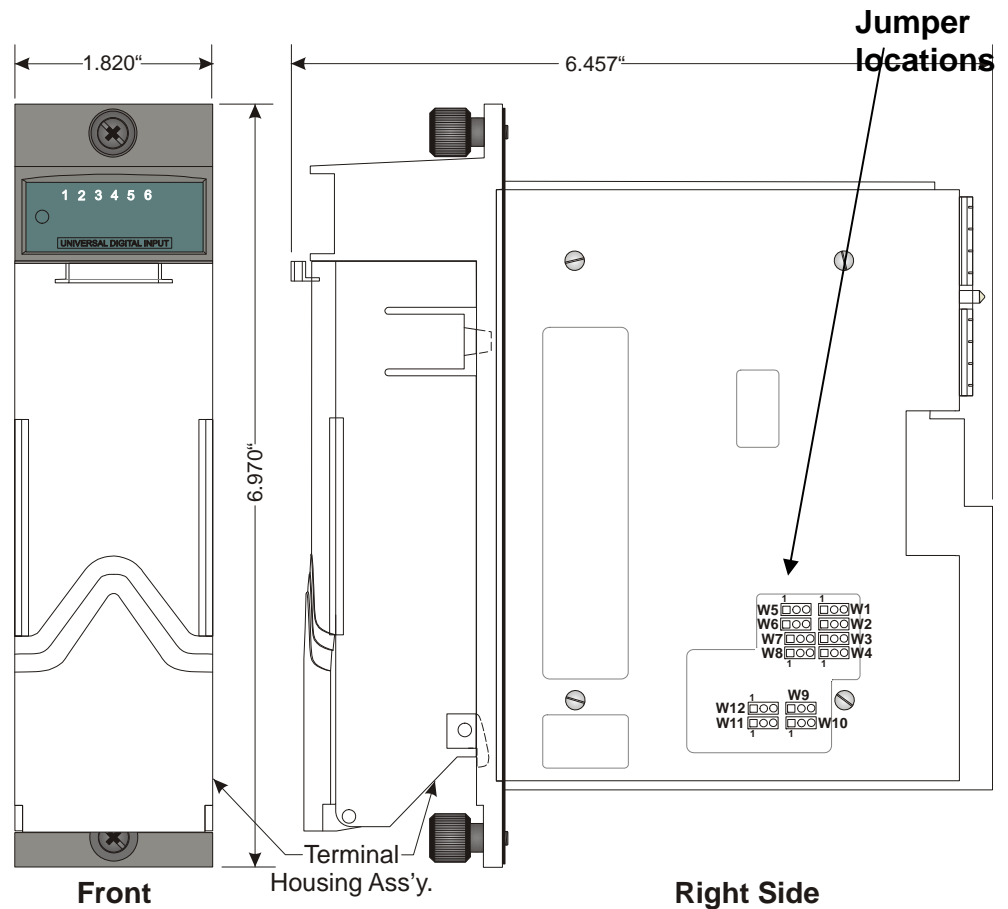

Figure 3-24. - UDI Module -Right Side View -Jumper Locations

Table 3-13. Jumper Assignments: UDI Module

Jumper	Purpose	Description
W1	Configures UDI1	Pins 1-2 installed = Enable Debounce (Factory default). A change of state on both the SET and RST (reset) field inputs is required to accumulate counts. Pins 2-3 installed = Disable Debounce. A change of state on the SET field input is required to accumulate counts.
W2 through W6	Configures UDI 2 through UDI6	Pins 1-2 installed = Enable Debounce (Factory default). A change of state on both the SET and RST (reset) field inputs is required to accumulate counts. Pins 2-3 installed = Disable Debounce. A change of state on the SET field input is required to accumulate counts.

Wiring the Module Figure 3-27 shows field wiring assignments for the locally terminated UDI module. It also includes examples for relay contact and open collector applications. Figure 3-28 shows field wiring assignments for the remotely terminated UDI module.

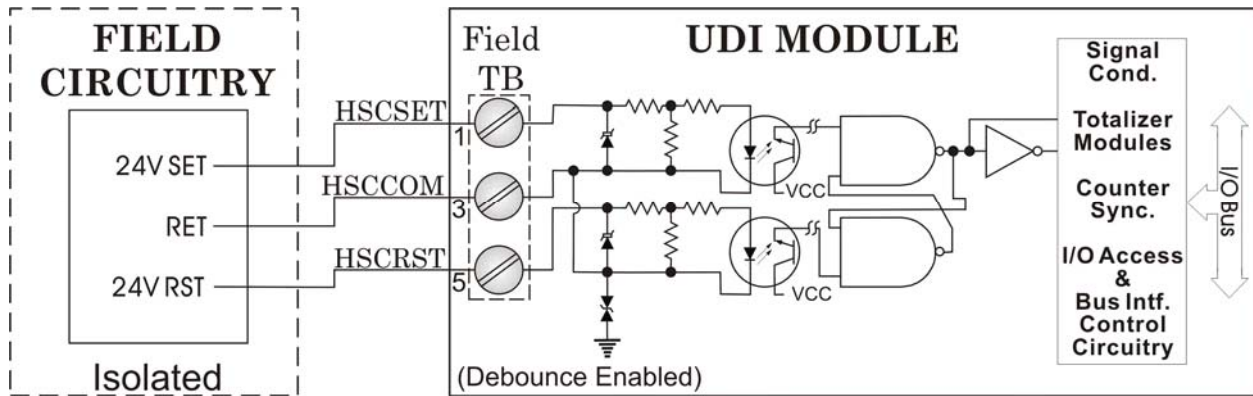

Figure 3-25. UDI (Debounce Enabled) Wiring Diagram

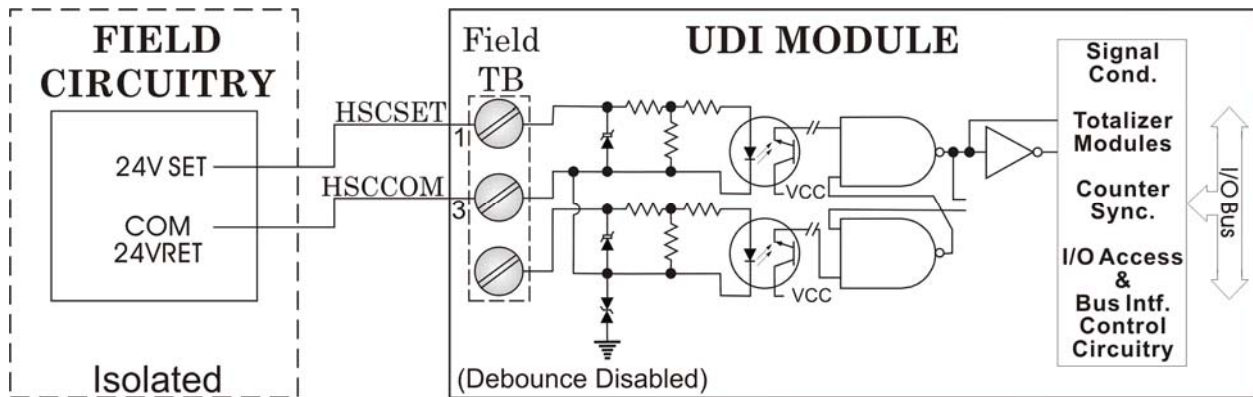

Figure 3-26. UDI (Debounce Disabled) Wiring Diagram

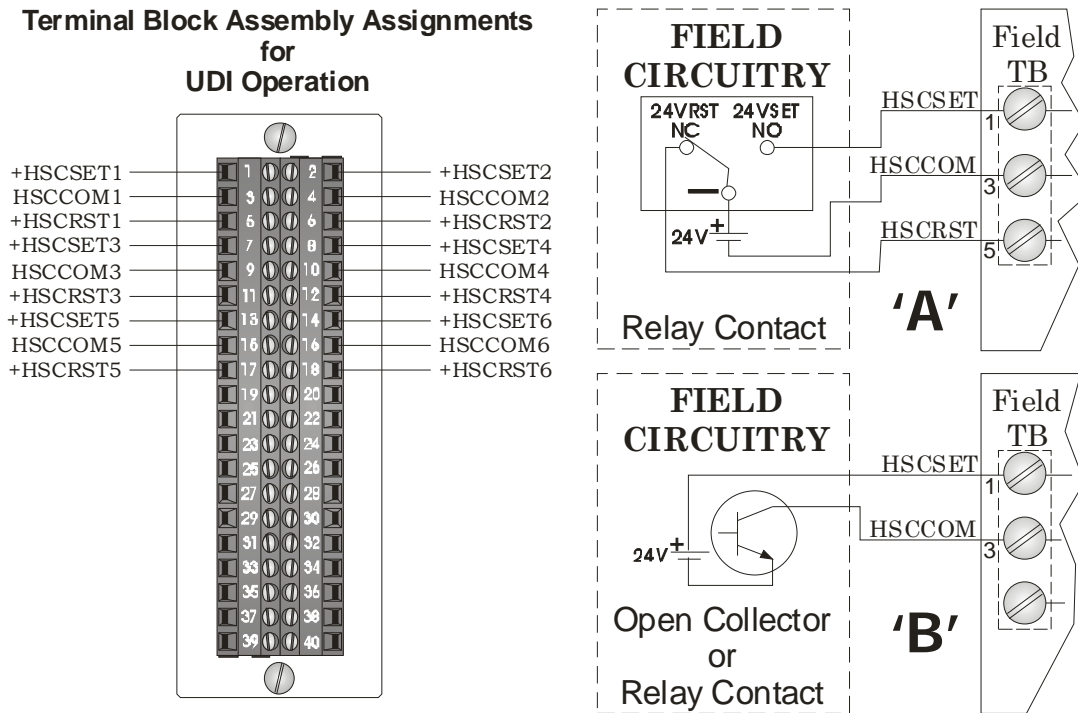
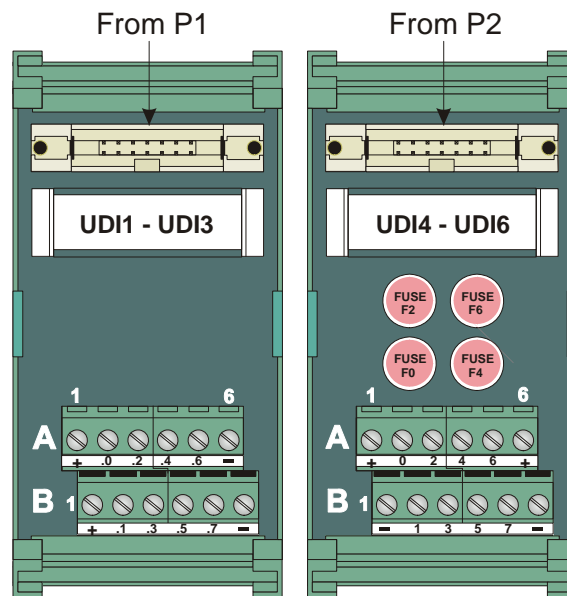
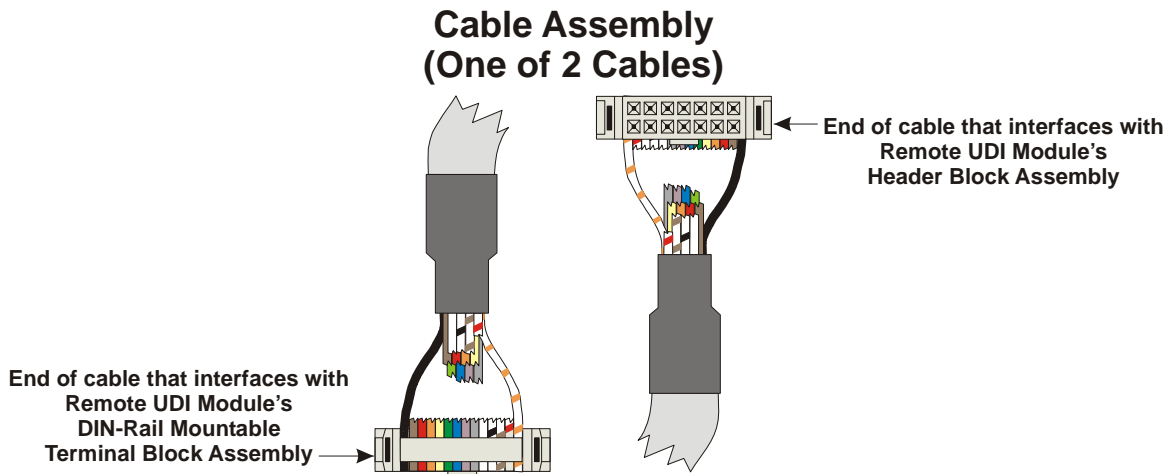

Figure 3-27. Local UDI Terminal Block/Configuration Diagram



**12/24V UDI
(without fuses)**

A = Top TB

- + = N/A
- .0 = UDISET1
- .2 = UDIRST1
- .4 = UDICOM2
- .6 = UDISET3
- = UDIRST3

B = Bottom TB

- + = N/A
- .1 = UDICOM1
- .3 = UDISET2
- .5 = UDIRST2
- .7 = UDICOM3
- = UDIRST3

**12/24V UDI
(with fuses)**

A = Top TB

- + = N/A
- 0 = UDISET4
- 2 = UDIRST4
- 4 = UDICOM5
- 6 = UDISET6
- + = N/A

B = Bottom TB

- = UDIRST6
- 1 = UDICOM4
- 3 = UDISET5
- 5 = UDIRST5
- 7 = UDICOM6
- = UDIRST6

FUSES: F0, F2, F4, F6: 1/8A

Figure 3-28. Remote DIN-Rail Mountable Terminal Block Assembly Assignments for UDI Operation

Software Configuration To use data from any ControlWave UDI module in the rack you must use ControlWave Designer's I/O Configurator to modify the ControlWave project in the host controller to add an **ER_HSC12** board and then configure it.

The I/O Configurator is where you specify the usage for each input using the **Select Filter** list box.

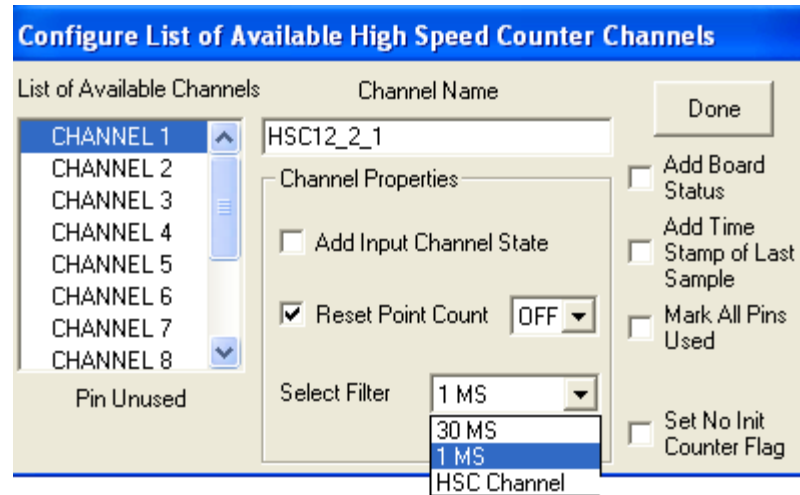

Figure 3-29. Selecting Input Type in ControlWave Designer I/O Configurator

Choose one of the following:

- “**HSC Channel**” to select a 20 microsecond delay for 10 kHz high speed counter applications.
- “**1 MS**” to select a 1 millisecond delay for a low speed counter application.
- “**30 MS**” to select a 30 millisecond delay for a polled input. This is for general purpose inputs or contacts where contact bounce may apply.

See the *ControlWave Designer Programmer's Handbook (D5125)* for more information. That same manual includes an *I/O Mapping* section that describes, for advanced users, the I/O map for this module.

3.9 Isolated Resistance Temperature Device (RTD) Input Module

RTD Input modules provide a total of four inputs. Firmware detects the RTD type (2-, 3- or 4 wire) via the installation of jumper wires on the terminal block for 2-wire and 3-wire RTDs (see *Figure 3-30*).

Table 3-14. Isolated RTD Input Module General Characteristics

Type	Number Supported	Characteristics
Isolated RTD Input	4	Each isolated RTD input supports/includes: <ul style="list-style-type: none"> ▪ Signal conditioning circuitry ▪ Surge protection with a 25V transorb that meets IEEE standard 472-1978 ▪ Current limiting for over voltage protection ▪ 24-bit analog to digital converter (ADC) ▪ Common mode range of 500V with respect to chassis ▪ Electrical isolation of 500Vdc (channel to channel/system bus) ▪ Source current to RTD limited to 330 uA

The RTD Input Module consists of an isolated RTD input board, a terminal board assembly (for local termination) or a header block assembly (for remote termination), an LED board, a terminal housing assembly, as well as I/O assembly and mounting hardware.

Detailed Technical Specifications

For additional technical specifications, please see document CWPAC:TEMP available on our website <http://www.emersonprocess.com/remote>.

Configuration

The isolated RTD module (general part number **396878-XX-X**) has the following configurations

Table 3-15. Isolated RTD Input Module Configurations

Part Number	Termination Connector	Notes
396878-01-6	local	
396878-02-4	remote	

Enabling/Disabling LEDs using jumper

The Isolated RTD Module includes a jumper (W1) to enable/disable LEDs on the module. Normally, you should keep the LEDs enabled, but if power conservation is an issue, you could disable the LEDs.

Table 3-16. Jumper Assignments: Non-isolated HSC Module

Jumper	Purpose	Description
W1	Enables/disables LEDs on module	Pins 1-2 installed = Enable LEDs (Factory default). Pins 2-3 installed = Disable LEDs

Wiring the Module *Figure 3-31* shows field wiring assignments for locally terminated isolated RTD modules. *Figure 3-32* shows field wiring assignments for remotely terminated isolated RTD modules.

Figure 3-30 provides wiring diagrams for 2-wire, 3-wire, and 4-wire RTDs to the local RTD module terminal blocks; wiring assignments, such as +RTD#_3/4W, -RTD#_4W, +RTD# and -RTD# are similar to those assigned to the Remote DIN-rail mountable terminal blocks.

Note: To maintain specified accuracy with a 3-wire RTD, you must match the two field wires that source and sink the RTD current within 0.01 ohms (matched in length and matched in wire type) and the ambient temperature on these wires must be the same.

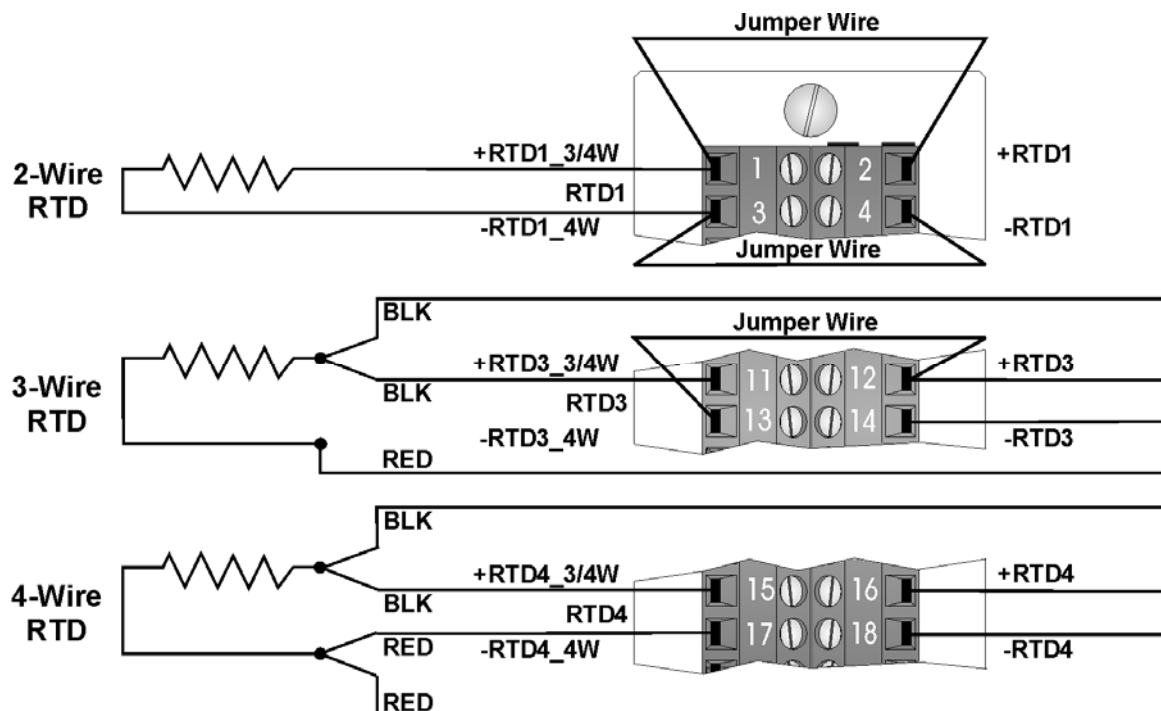

Figure 3-30. Isolated RTD Module - 2-Wire, 3-Wire & 4-Wire Wiring Diagram

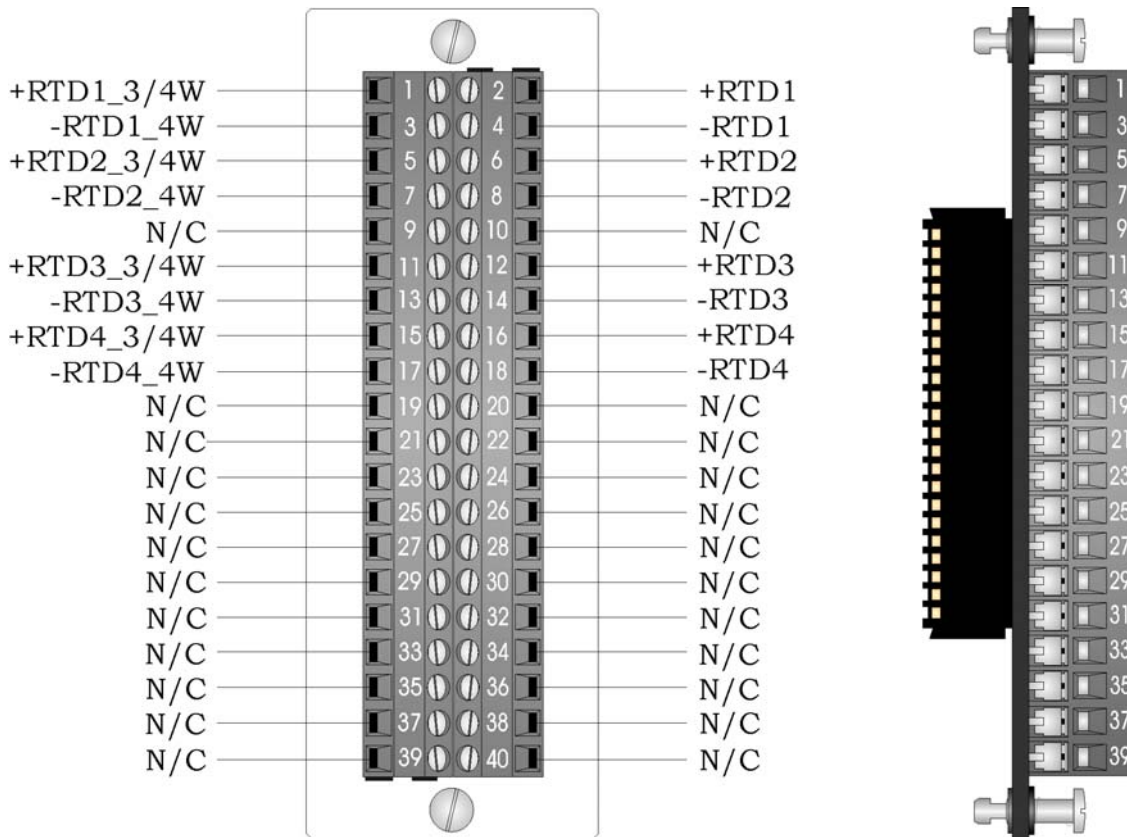

Figure 3-31. Local Isolated RTD Module Terminal Block Assembly Assignments

Software Configuration To use data from any ControlWave RTD module in the rack you must use ControlWave Designer's I/O Configurator to modify the ControlWave project in the host controller to add an **ER_RTDS8** board and then configure it. See the *ControlWave Designer Programmer's Handbook* (D5125) for more information. That same manual includes an *I/O Mapping* section that describes, for advanced users, the I/O map for this module.

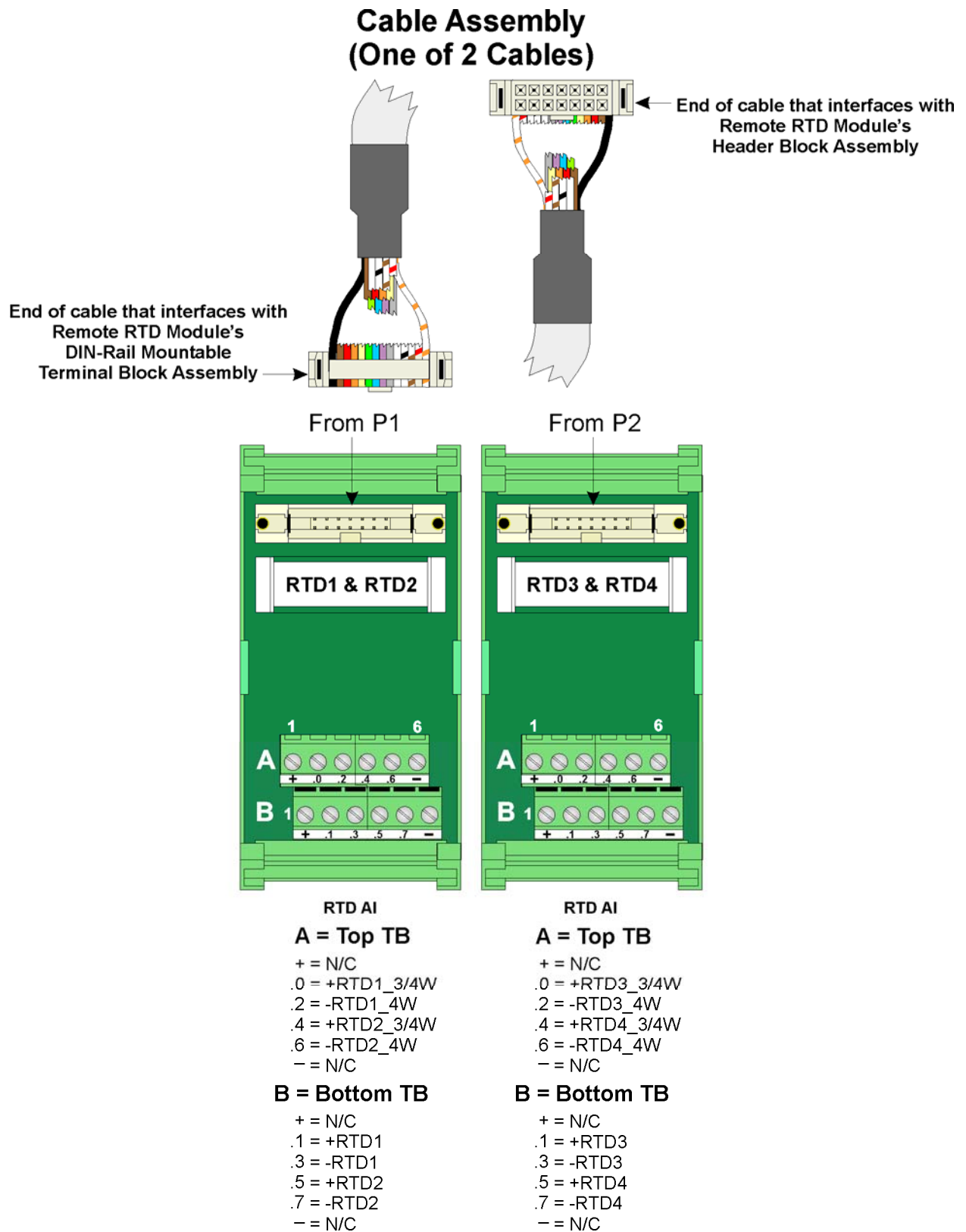

Figure 3-32. Remote DIN-Rail Mountable Terminal Block Assembly Assignments for Isolated RTD Module Operation

3.10 Isolated Thermocouple Module

Thermocouple modules (sometimes known as low level analog input modules) provide six individually isolated differential inputs for thermocouples or $\pm 10\text{mV}$ inputs plus one cold junction compensation (CJC) input for temperature compensation at the terminal block.

Table 3-17. Thermocouple Module General Characteristics

Type	Number Supported	Characteristics
Thermocouple	6	Each isolated thermocouple supports/includes: <ul style="list-style-type: none"> ▪ Signal conditioning circuitry including a 2.5V reference ▪ Surge suppression with a 188V Transorb that meets IEEE standard 472-1978. ▪ Over voltage protection ▪ Common mode range for each channel is 500Vdc with respect to chassis. ▪ 24-bit analog to digital converter (ADC)

Detailed Technical Specifications For additional technical specifications, please see document CWPAC:TEMP available on our website <http://www.emersonprocess.com/remote>.

Configuration The isolated thermocouple module (general part number **396877-XX-X**) has the following configurations:

Table 3-18. Isolated Thermocouple Module Configurations

Part Number	Termination Connector	Notes
396877-01-0	local	
396877-02-8	remote	

Enabling/Disabling LEDs using jumper The Isolated Thermocouple Module includes a jumper (W2) to enable/disable LEDs on the module. Normally, you should keep the LEDs enabled, but if power conservation is an issue, you could disable the LEDs.

Table 3-19. Jumper Assignments: Isolated Thermocouple Module

Jumper	Purpose	Description
W2	Enables/disables LEDs on module	Pins 1-2 installed = Enable LEDs (Factory default). Pins 2-3 installed = Disable LEDs

Wiring the Module *Figure 3-34* shows field wiring for locally terminated isolated thermocouple modules. *Figure 3-35* shows field wiring for remotely terminated isolated thermocouple modules.

The cold junction compensation (CJC) with a built-in RTD provides thermocouple temperature compensation at the terminal block and is electrically isolated. Pins 8, 9 and 10 of the local terminal block source and sink the CJC's RTD.

Figure 3-35 also provides diagrams showing the wiring for thermocouples and the 3-wire RTDs to a locally terminated thermocouple module. Wiring assignments (that is, +AI#, -AI#, +CJC (Sense), -CJC (Return) & +CJC (Reference)) are similar to those assigned to the remote DIN-rail mountable terminal blocks. A small CJC PCB is factory-installed to the terminal block.

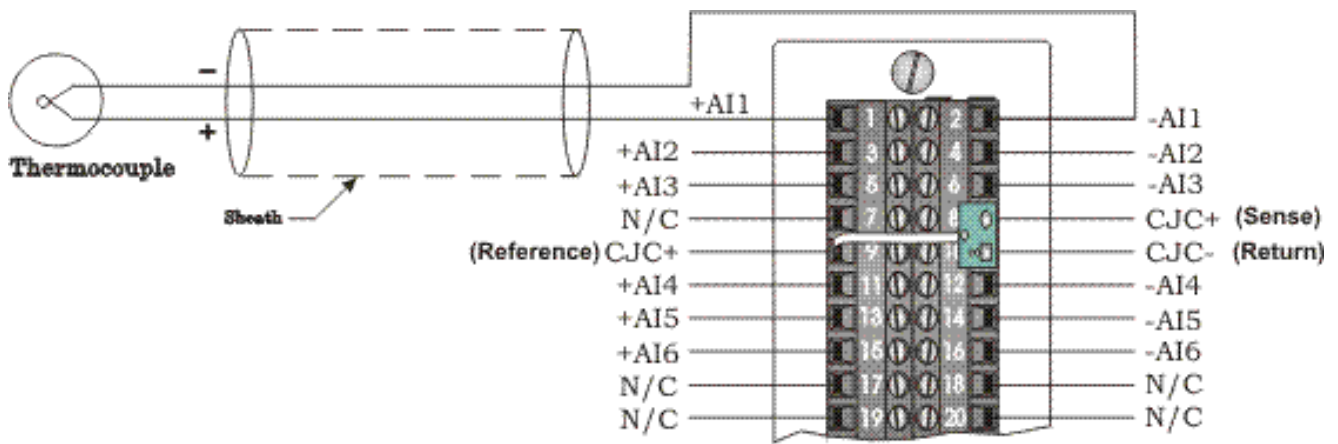

Figure 3-33. Isolated Thermocouple Module Wiring Diagram

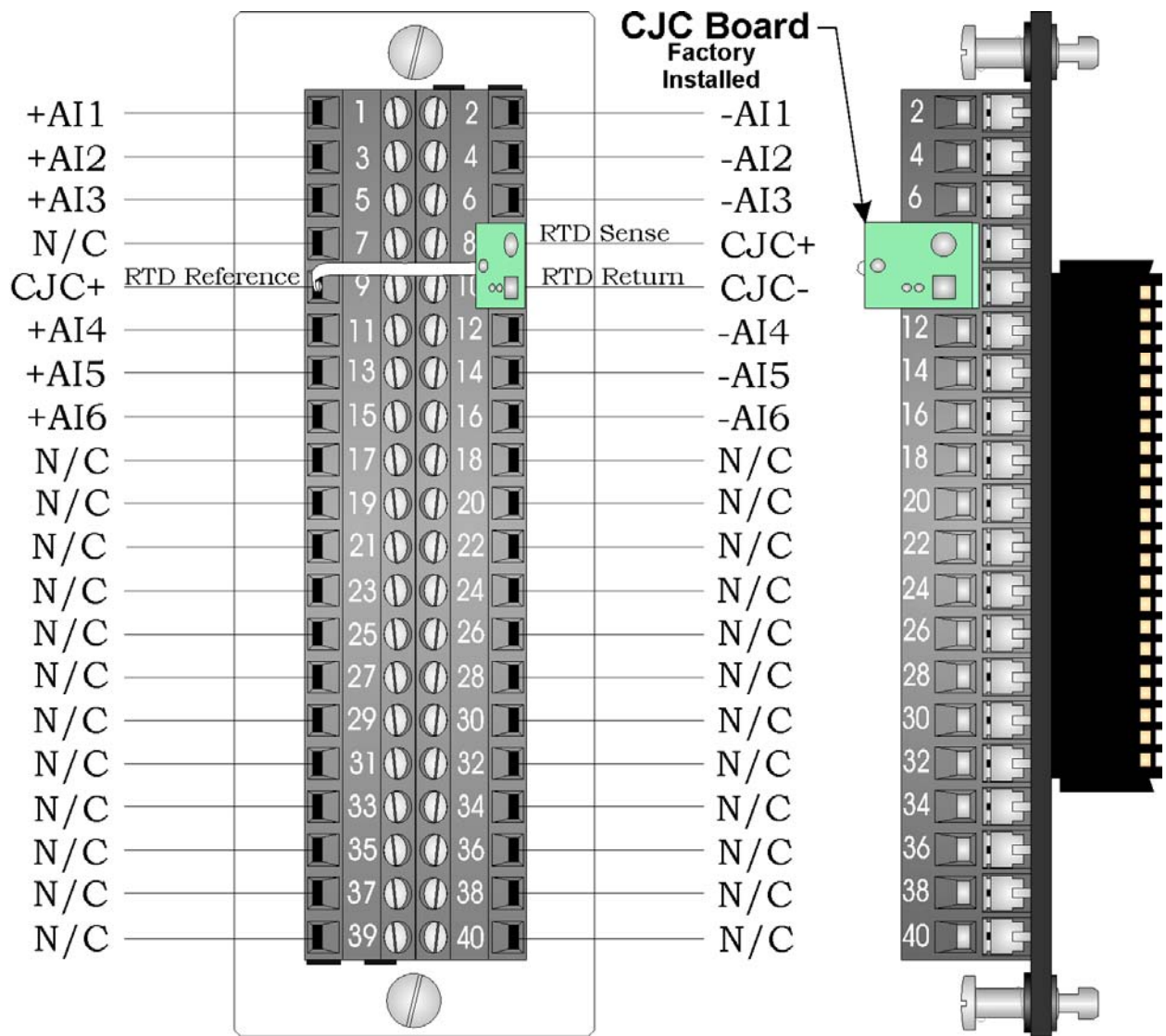

Figure 3-34. Local Isolated Thermocouple Module Terminal Block Assembly Assignments

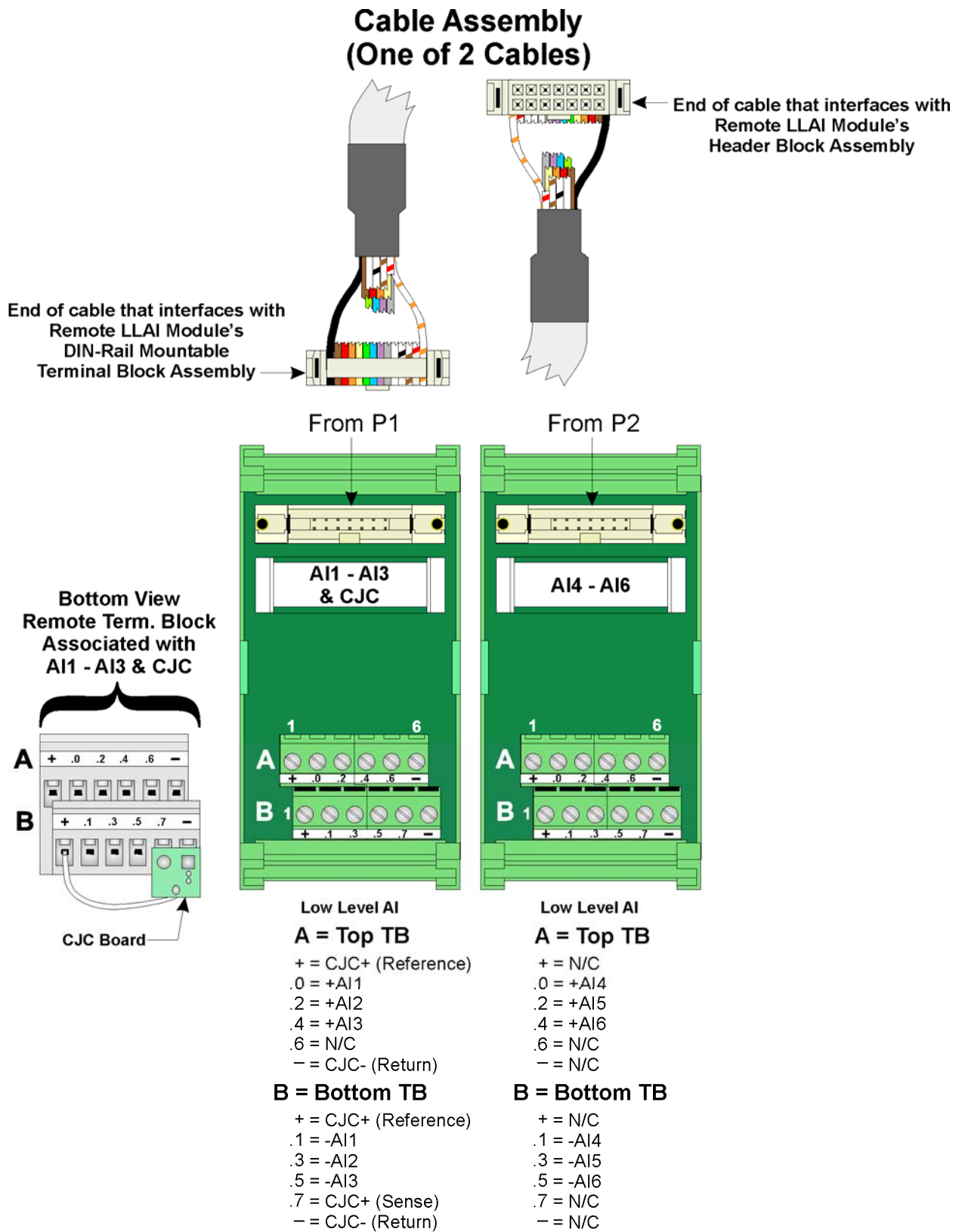

Figure 3-35. Remote DIN-Rail Mountable Terminal Block Assembly Assignments for Isolated Thermocouple Module Operation

Ranges & Errors *Table 3-20* provides the accuracy, resolution and temperature range for the various thermocouples and 10mV LLAI inputs. *Table 3-21* lists the RTD error with the CJC.

Table 3-20. Thermocouple Module Input Accuracy and Resolution

Input Type	Accuracy/Range	Resolution	25°C	-20°C to +70°C
B – Thermocouple	100°C to 200°C	2.00°C	± 8°C	± 16°C
	200°C to 390°C	1.00°C	± 4°C	± 8°C
	390°C to 840°C	0.50°C	± 2°C	± 4°C
	840°C to 1820°C	0.20°C	± 1°C	± 2°C
R – Thermocouple	-50°C to +50°C	0.40°C	± 2°C	± 4°C
	+50°C to 1720°C	0.17°C	± 1°C	± 2°C
S – Thermocouple	- 50°C to +50°C	0.37°C	± 2°C	± 4°C
	+50°C to 1760°C	0.18°C	± 1°C	± 2°C
C – Thermocouple	0°C to 2315°C	0.16°C	± 0.75°C	± 1.5°C
N – Thermocouple	- 270°C to - 260°C	1.50°C	± 8°C	± 10°C
	- 260°C to - 250°C	0.75°C	± 4°C	± 8°C
	- 250°C to - 230°C	0.50°C	± 2°C	± 4°C
	- 230°C to - 150°C	0.25°C	± 1°C	± 2°C
	- 150°C to 1300°C	0.09°C	± 0.500°C	± 1°C
J – Thermocouple	- 210°C to 191°C	0.08°C	± 0.750°C	± 1.5°C
	190°C to 1200°C	0.11°C	± 0.500°C	± 1°C
E – Thermocouple	- 270°C to - 260°C	1.00°C	± 3°C	± 6°C
	- 260°C to - 225°C	0.25°C	± 1°C	± 2°C
	- 225°C to - 200°C	0.08°C	± 0.750°C	± 1.5°C
	- 200°C to 1000°C	0.09°C	± 0.500°C	± 1°C
K – Thermocouple	- 270°C to - 261°C	2.00°C	± 5°C	± 10°C
	- 260°C to - 246°C	0.56°C	± 2°C	± 4°C
	- 245°C to - 180°C	0.25°C	± 1°C	± 2°C
	- 179°C to - 145°C	0.08°C	± 0.750°C	± 1.5°C
	- 145°C to 1372°C	0.14°C	± 0.500°C	± 1°C
T – Thermocouple	- 270°C to - 261°C	1.50°C	± 4°C	± 8°C
	- 260°C to - 251°C	0.38°C	± 2°C	± 4°C
	- 250°C to - 181°C	0.18°C	± 1°C	± 2°C
	- 180°C to - 136°C	0.08°C	± 0.750°C	± 1.5°C
	- 135°C to - 400°C	0.06°C	± 0.500°C	± 1°C
± 10mV	± 10mV	1.2µV	± 0.25%	± 0.05%

Note: The CJC RTD adds an additional error (see *Table 3-21*)

Table 3-21. Thermocouple Module RTD Error with CJC at 25°C

Thermocouple Type	Process Temperature Range	RTD Error with CJC @ 25°C
B	100°C to 1820°C	± 0.30°C
R	- 50°C to +50°C	± 0.49°C
	+50°C to 1720°C	± 0.30°C
S	- 50°C to +50°C	± 0.45°C
	+50°C to 1760°C	± 0.30°C

Thermocouple Type	Process Temperature Range	RTD Error with CJC @ 25°C
C	0°C to 2315°C	± 0.30°C
N	- 270°C to - 261°C	± 20.50°C
	- 260°C to - 251°C	± 5.00°C
	- 250°C to - 231°C	± 2.70°C
	- 230°C to - 189°C	± 1.40°C
	- 188°C to - 70°C	± 0.70°C
	- 70°C to + 25°C	± 0.35°C
J	+25°C to 1300°C	± 0.30°C
	- 210°C to - 111°C	± 0.80°C
	- 110°C to +25°C	± 0.40°C
E	+25°C to 1200°C	± 0.30°C
	- 270°C to - 261°C	± 10°C
	- 260°C to - 245°C	± 3°C
	- 244°C to - 200°C	± 1.50°C
	- 200°C to - 87°C	± 0.75°C
	- 86°C to +25°C	± 0.39°C
K	+25°C to 100°C	± 0.30°C
	- 270°C to - 261°C	± 15.00°C
	- 260°C to - 247°C	± 4.50°C
	- 246°C to - 222°C	± 2.20°C
	- 220°C to - 160°C	± 1.10°C
	- 159°C to +25°C	± 0.55°C
T	+25°C to 1372°C	± 0.30°C
	- 270°C to - 261°C	± 10.30°C
	- 260°C to - 243°C	± 3.00°C
	- 242°C to - 196°C	± 1.50°C
	- 195°C to - 61°C	± 0.75°C
	- 60°C to +25°C	± 0.375°C
	+25°C to 400°C	± 0.30°C

Note: Use straight-line approximation to calculate approximate error between end points.

Software Configuration To use data from any ControlWave thermocouple module in the rack you must use ControlWave Designer's I/O Configurator to modify the ControlWave project in the host controller to add an **ER_TC12** board and then configure it. See the *ControlWave Designer Programmer's Handbook (D5125)* for more information. That same manual includes an *I/O Mapping* section that describes, for advanced users, the I/O map for this module.

This page is intentionally left blank

Chapter 4 – Operation

This chapter provides general operational details for using the ControlWave I/O expansion rack.

In This Chapter

4.1	Powering Up/Powering Down the ControlWave I/O Expansion Rack	4-1
4.2	Communicating with the ControlWave I/O Expansion Rack	4-1
4.2.1	Default Comm Port Settings	4-1
4.2.2	Changing Port Settings	4-2

4.1 Powering Up/Powering Down the ControlWave I/O Expansion Rack

Open the bezel door on the PSSM and position the power switch (or switches if you have dual supplies) to the OFF (down) position to turn the ControlWave I/O rack OFF or to the ON (up) position to turn it ON.



ON position (up) to turn ON the power supply



OFF position (down) to turn OFF the power supply

Figure 4-1. Power Switches on PSSM Setting the Operating Mode (Run/Remote/Local Switch)

4.2 Communicating with the ControlWave I/O Expansion Rack

You communicate to the ControlWave I/O rack by connecting a cable between a port on your PC workstation and one of the ControlWave I/O rack ports. See *Section 2.4* for more information on communications.

The port at the PC workstation must match the configuration of the ControlWave I/O rack port.

4.2.1 Default Comm Port Settings

As delivered from the factory, ControlWave communication ports have default settings. *Table 4-1* details these defaults.

Table 4-1. Default Comm Port Settings (by PCB)

Port	PCB	Default Configuration
COM1	CPU	Ships from factory at RS-232; 115.2 Kbps using BSAP. Once the default switch is OFF, a factory default of IP Point-to-Point protocol (PPP) at 115,200 applies with an IP address of 1.1.1.1 and a mask of 255.255.255.255.
COM2	CPU	RS-232; 9600 baud, 8 bits, no parity, 1 stop bit, RTU message type

Port	PCB	Default Configuration
		Modbus Slave protocol
COM3	SCB	RS-485; 9600 baud, 8 bits, no parity, 1 stop bit, BSAP or ControlWave Designer protocol
COM4	SCB	RS-232; 9600 baud, 8 bits, no parity, 1 stop bit, BSAP or ControlWave Designer protocol

Note: You can re-enable the factory comm settings at any time by setting switch 3 on the CPU module's SW1 to "OFF."

Ethernet The ControlWave I/O expansion rack can include one or three Ethernet ports. You can connect directly or through a network to a PC equipped with an Ethernet port.

The factory pre-configures the initial IP addresses and masks to:

- ETH1 IP Address: 10.0.1.1 IP Mask: 255.255.255.0
- ETH2 IP Address: 10.0.2.1 IP Mask: 255.255.255.0
- ETH3 IP Address: 10.0.3.1 IP Mask: 255.255.255.0

Because each unit ships from the factory with these addresses initially pre-programmed, you should only use these addresses for "bench" testing and configuration. You must change these addresses before putting the I/O rack on an actual network, since an address conflict would exist as soon as you place the second ControlWave unit online.

4.2.2 Changing Port Settings

You change port settings (baud rate, port type, IP address, and so on) using the Flash Configuration utility.

You must establish communications with the ControlWave using NetView, LocalView, or TechView before you can run the Flash Configuration utility.

Note: For detailed information on using the Flash Configuration utility, see *Chapter 5* of the *OpenBSI Utilities Manual (D5081)*.

 **Caution**

When you change the baud rate for a port, the baud rate changes as soon as you write the flash file changes to the RTU, and do not require a reset. For this reason, you should not change baud rate for the active port on which you are communicating, or communications will immediately stop due to the baud rate mismatch between the PC port and the controller port. If this happens accidentally, you can use CPU switch settings as discussed in the notes in *Section 4.2.1* to restore defaults and re-establish communications.

Chapter 5 – Service and Troubleshooting

This chapter provides general diagnostic and test information for the ControlWave I/O expansion rack.

In This Chapter

5.1	Upgrading Firmware	5-2
5.2	Removing or Replacing Components.....	5-5
5.2.1	Accessing Modules for Testing	5-5
5.2.2	Removing/Replacing the Bezel	5-5
5.2.3	Removing/Replacing the CPU Module.....	5-6
5.2.4	Removing/Replacing the PSSM.....	5-6
5.2.5	Removing/Replacing an I/O Module (Hot Swapping)	5-7
5.2.6	Removing/Replacing the Backup Battery	5-12
5.3	General Troubleshooting Procedures	5-13
5.3.1	Common Communication Configuration Problems.....	5-13
5.3.2	Checking LEDs.....	5-14
5.3.3	Checking Wiring/Signals	5-22
5.3.4	Port 80 Display Codes.....	5-22
5.3.5	Reset Switch	5-26
5.4	WINDIAG Diagnostic Utility	5-26
5.4.1	Available Diagnostics	5-28
5.5	Core Updump	5-32

Equipment You need the following equipment to perform the procedures described in this chapter:

To run diagnostics software:

- PC with WINDIAG software, and either OpenBSI LocalView, NetView, or TechView for communications.
- Null modem interface cable
- Loop-back plug for RS-232 port (see *Figure 5-22*)
- Loop-back plug for RS-485 port (see *Figure 5-23*)
- Loop-back plug, 8-pin RJ-45 male (for twisted pair Ethernet) (see *Figure 5-25*)

To perform firmware upgrades:

- Null modem interface cable
- PC with the following software:
 - o OpenBSI System Firmware Downloader and either NetView, LocalView, or TechView for communications.
 - o HyperTerminal (included in Windows® XP)

Note: When you service a ControlWave on site, we recommend that you close down (or place under manual control) any associated processes. This precaution prevents any processes from accidentally running out of control when you conduct tests.

 **Warning** Harmful electrical potentials may still exist at the field wiring terminals even though the ControlWave power source may be turned off or disconnected. Do not attempt to unplug termination connectors or perform any wiring operations until you verify that all associated power supply sources are turned off and/or disconnected.

Always turn off any external supply sources for externally powered I.O circuits before you change any modules.

5.1 Upgrading Firmware

The ControlWave I/O expansion rack CPU ships from the factory with system firmware already installed. If you need to upgrade the system firmware (stored in Flash memory) to acquire new functionality or restore firmware, you can use one of several methods.

System Firmware Downloader Use this tool to download system firmware to an unattended remote I/O rack. To use this utility, you must set CPU module switch SW3-2 **OFF** (the factory default position).

Note: For further information and detailed use instructions, refer to *Appendix J of the OpenBSI Utilities Manual (D5081)*.

LocalView One of the standard OpenBSI utilities, LocalView requires OpenBSI version 5.1 (or newer). If you have an older version of OpenBSI, use HyperTerminal.

Note: For further information and detailed use instructions, refer to the Flash Mode section of *Chapter 5 of the OpenBSI Utilities Manual (D5081)*.

HyperTerminal HyperTerminal is a communications utility program included with Microsoft® Windows®.XP

Notes:

- If you are using a version of OpenBSI older than 5.1, or do not have OpenBSI software, you can only perform a firmware upgrade using HyperTerminal.
- While HyperTerminal is included in Microsoft® Window® XP, some newer versions of Window® do not include it.
- HyperTerminal requires *.BIN files; newer ControlWave firmware upgrade files use *.CAB files. In cases such as those, you should use the Remote System Firmware Downloader.

1. Connect a null modem cable between COM1 of the ControlWave and any RS-232 port on the associated PC.
2. Click **Start > Programs > Accessories > Communications > HyperTerminal**

3. If using HyperTerminal for the first time, set the communication properties (for the PC port) via the Properties Menu as follows: Bits per second: = 115200, Data bits: = 8, Parity: = None, Stop bits: = 1, and Flow control: = None and then click **OK**.
4. Set CPU switch SW3-3 to **ON** (Force Recovery Mode).
5. Apply power; to the ControlWave. The resident BIOS initializes and tests the hardware, this process is referred to as POST (Power On Self Test). Unless there is a problem, you should see the code “86” on the Port 80 display. If you see a different status code, see *Section 5.3.4*.
6. From the HyperTerminal Mode menu (*Figure 5-1*), press the **F** key to enter FLASH download. A message warns that the FLASH is about to be erased; press the **Y** key at the prompt. The screen displays dots as the system erases the flash memory; this could take a few minutes.

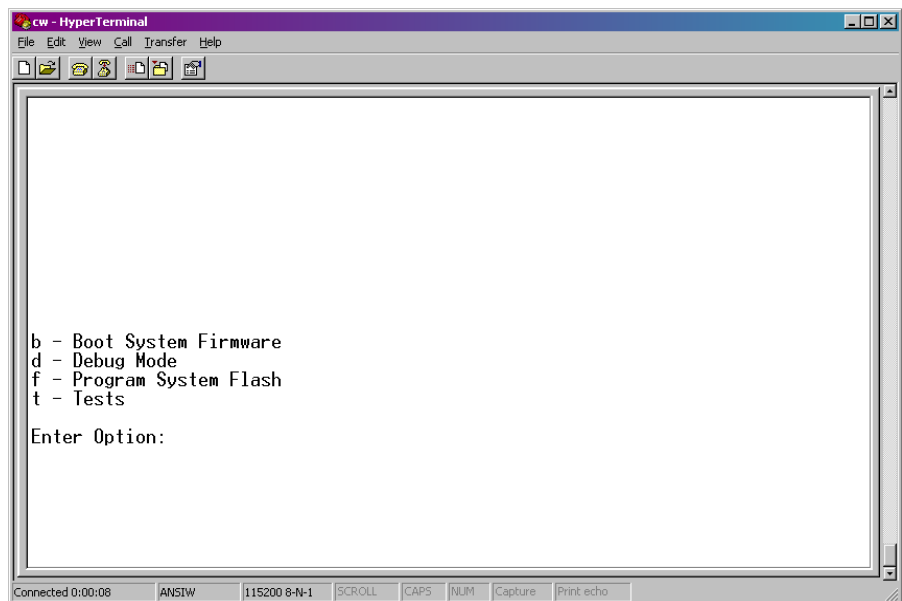

Figure 5-1. HyperTerminal Mode Menu

7. When the FLASH is ready for download, HyperTerminal repeatedly displays the letter C on the screen. In the HyperTerminal menu bar click **Transfer > Send File** (see *Figure 5-2*).

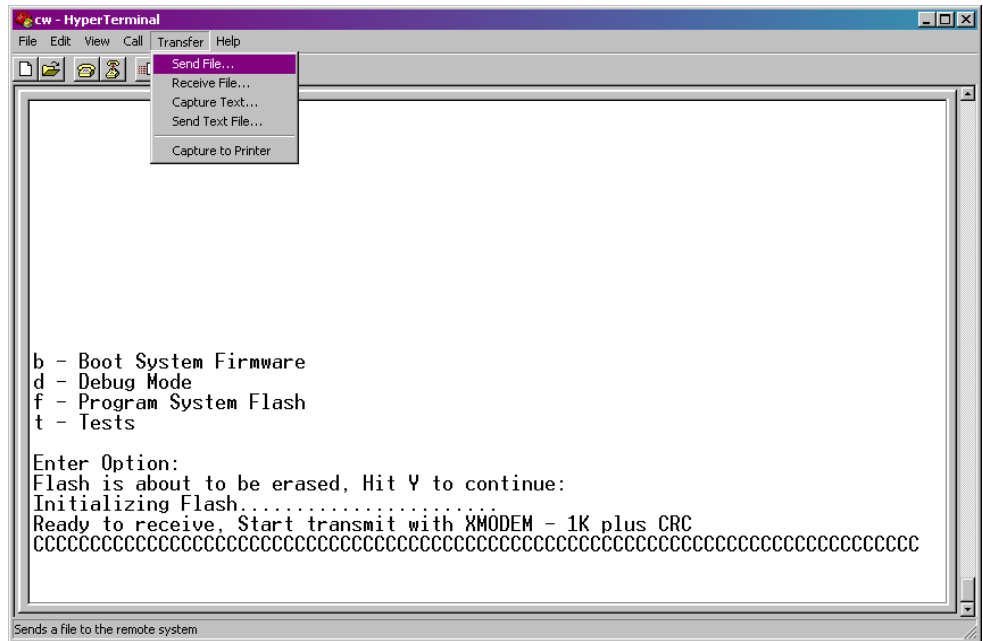

Figure 5-2. HyperTerminal (Ready to Download)

8. In the Send File dialog box (see Figure 5-3), select **1KXmodem** for the protocol, enter the filename of the appropriate .bin file in the format "CWPxxxxx.bin" (where xxxxx varies from release to release) and click **Send** to start the flash upgrade (see Figure 5-4). When you see the HyperTerminal Mode Menu again, it means the download has completed.
9. Exit HyperTerminal and power down the ControlWave. If desired, you can disconnect the null modem cable between the ControlWave and the PC.
10. Set CPU switch SW3-3 to **OFF** (Recovery Mode Disabled).
11. Restore power to the ControlWave I/O expansion rack.

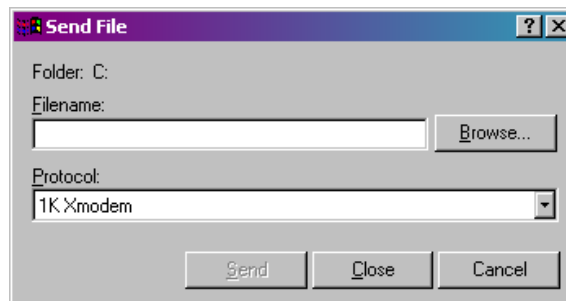

Figure 5-3. Send File dialog box

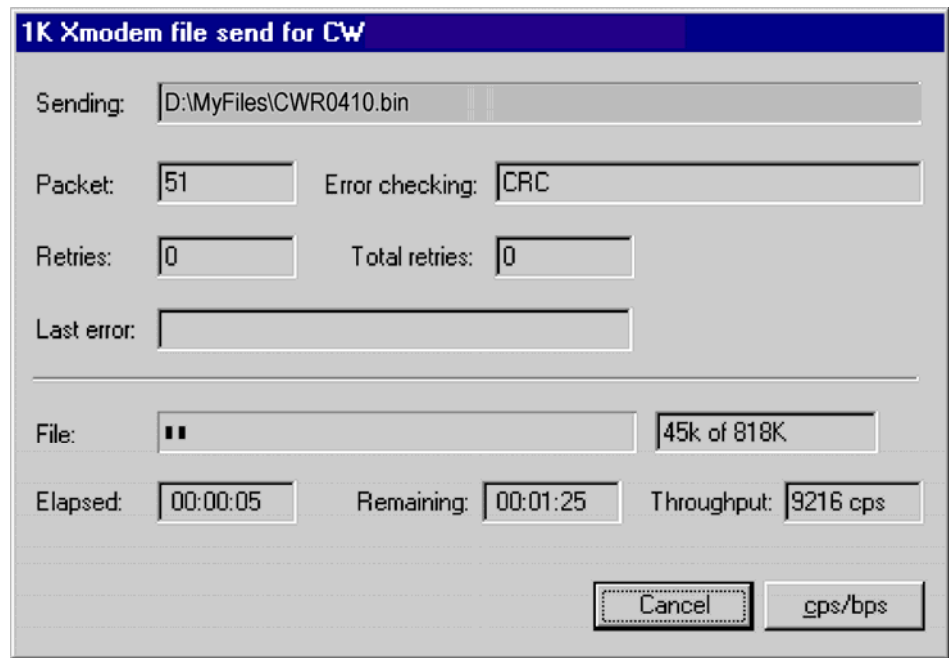

Figure 5-4. HyperTerminal (Download in Process)

5.2 Removing or Replacing Components

This section provides information on accessing ControlWave modules for testing, as well as removal/replacement procedures.



Caution

Field repairs to ControlWave process automation controllers are strictly limited to the replacement of complete modules. All modules (CPU, PSSM, and I/O) are factory sealed to prevent tampering. Breaking the seal and/or replacing module components constitutes tampering and voids the product warranty. Return defective modules or housings to the factory for authorized service.

5.2.1 Accessing Modules for Testing

Only technically qualified personnel should test and/or replace ControlWave modules. Read completely the disassembly and test procedures described in this manual before starting. Any damage to the ControlWave I/O rack resulting from improper handling or incorrect service procedures is not covered under the product warranty agreement. If you cannot properly perform these procedures, obtain authorization and then return the device to the factory for evaluation and repairs.

5.2.2 Removing/Replacing the Bezel

Before you can remove the CPU module or the PSSM module you must remove the bezel.

1. Remove any cables from their connectors; make sure you label the cables so you can replace them later.

2. Grasp the sides of the bezel assembly and gently pull it off the chassis.
3. To replace the bezel, align the bezel's two snaps (one near the top and one near the bottom) with the associated holes on the chassis. (These holes are centered between the PSSM and CPU captured panel fastener holes.)
4. Press the bezel in gently until it snaps into place.
5. Reconnect the cables if necessary.

5.2.3 Removing/Replacing the CPU Module

Use this procedure to remove or replace the CPU module.

1. If the ControlWave I/O expansion rack is running, place any critical control processes under manual control.
2. Shut off the power using the PSSM power switch.
3. Disconnect any CPU module communication cables. Label or otherwise identify them so you can easily return them to their assigned communication ports. .
4. Remove the bezel. (See *Section 5.2.2.*)
5. Loosen the two captured panel fasteners that secure the CPU module to the chassis and carefully slide it out the front of the chassis. You may need to rock the board back and forth gently to do this.
6. To replace a CPU module, the PSSM must already reside in slot 1, but power must be off. Carefully align the CPU module with the guides for slot 2 and insert the CPU module into the housing. When the module correctly seats in the backplane, turn the module's captured panel fasteners clockwise to secure the CPU module; this establishes a low resistance path between the CPU module and chassis ground. Make sure the fasteners are tight, but don't over-tighten them.
7. Replace any communication cables, restore power, and test the module.

5.2.4 Removing/Replacing the PSSM

Use this procedure to remove or replace the PSSM module.

1. If the ControlWave I/O expansion rack is running, place any critical control processes under manual control.
2. Shut down the unit by turning off the power.
3. Unplug the cables and PSSM modular connectors for power (TB1 and TB2) and watchdog (TB3).
4. Remove the bezel assembly. See *Section 5.2.2.*

5. Remove the CPU module. See *Section 5.2.3*. You must remove the CPU module in order to remove the PSSM.
6. Loosen the two captured panel fasteners that secure the PSSM module to the chassis and carefully slide it out the front of the chassis.
7. To replace a PSSM module, power must be off and the CPU module must be removed. Carefully align the PSSM module with the guides for slot 1 and insert the module into the housing. When the module correctly seats in the backplane, turn the module's captured panel fasteners clockwise to secure the PSSM module; this establishes a low resistance path between the PSSM module and chassis ground. Make sure the fasteners are tight, but don't over-tighten them.
8. Replace the CPU module.
9. Replace power and watchdog cables and then restore power and test the unit.

5.2.5 Removing/Replacing an I/O Module (Hot Swapping)

**WARNING**

DO NOT ATTEMPT hot swapping in a Class I, Division 2 hazardous location.

The ControlWave I/O expansion rack supports removal of any or all I/O modules from the housing while the application is running. This is called “hot swapping.” When you initially remove or replace any I/O module, the ControlWave I/O rack halts operation for 300 milliseconds before resuming operation from where it halted. During this momentary halt, the Port 80 display shows “CA” on its screen.

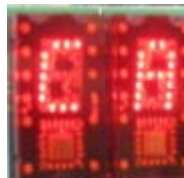
**Caution**

Never try to “hot swap” more than one I/O module simultaneously. You can remove or replace multiple modules sequentially, but not at the same time.

1. If the ControlWave I/O rack is running, place any critical control processes that use this I/O module under manual control.
2. Loosen the capture fasteners at the top and bottom of the module by turning them counter-clockwise.

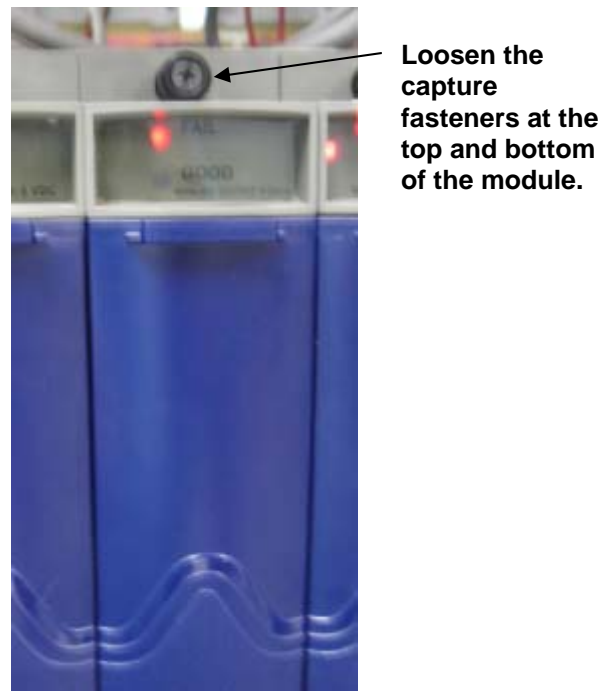

Figure 5-5. I/O Module to Be Replaced

3. Open the bezel door and grasp the handle. Pull the entire module out of the chassis.

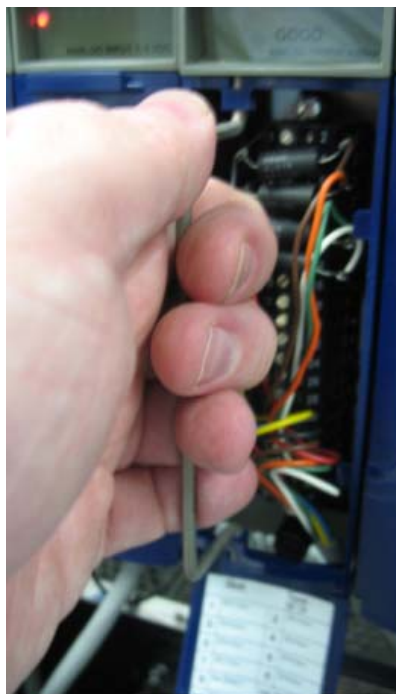
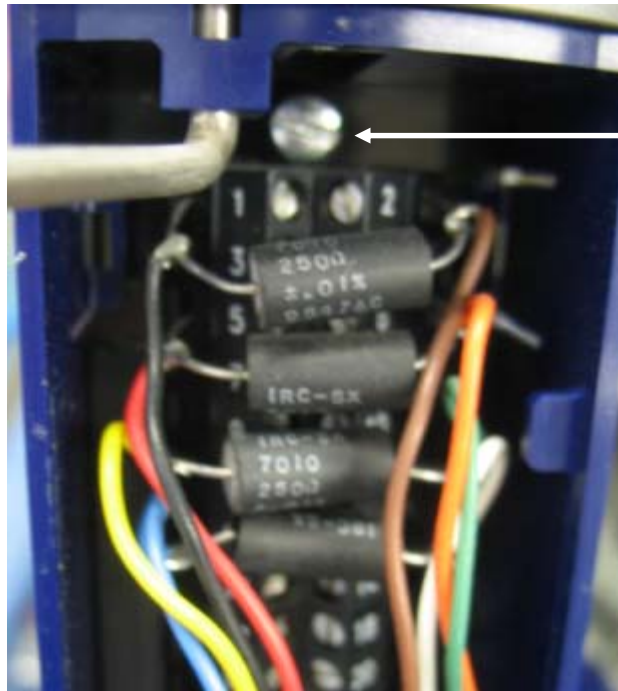

Figure 5-6. Pulling the I/O Module Out of the Housing

4. If you plan to replace this module with a new module, but want to retain all your existing I/O wiring to the terminal blocks, you need to disconnect the terminal block board from the rest of the

module. To do that, loosen the screws at the top and bottom of the terminal block board. Then grab the handle and pull the terminal block board along with the terminal housing assembly off of the front of the module.



Loosen the fasteners at the top and bottom of the terminal board.

Figure 5-7. Loosening the Top Fastener

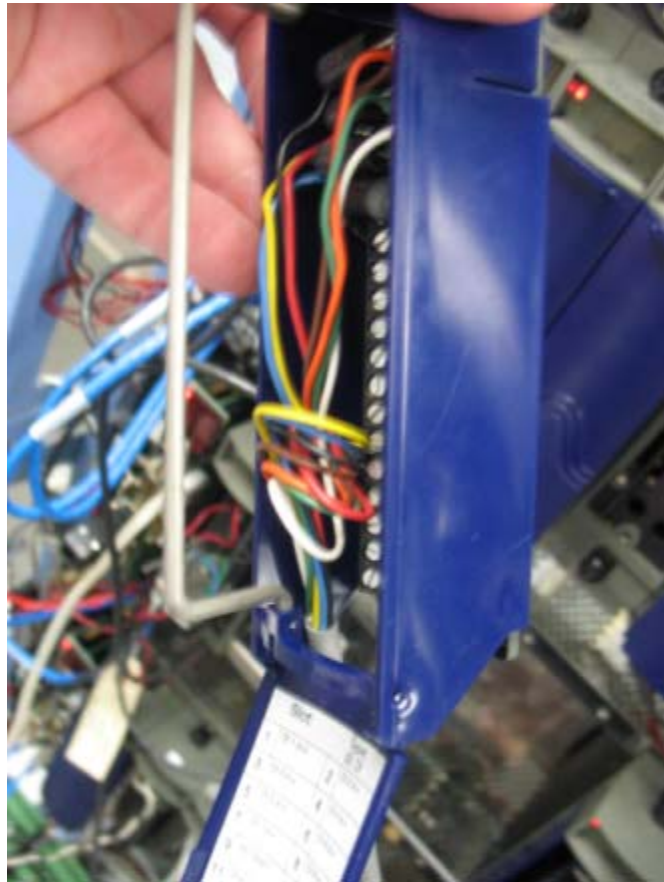

Figure 5-8. Terminal Block Board and Terminal Housing Assembly Separated from the Rest of the Module

5. Again, assuming you want to preserve your existing wiring to the terminal blocks, because you haven't wired to the terminal blocks on the replacement module, remove the terminal block board and terminal housing assembly *from the new replacement module*.
6. Carefully slide the new module into the same I/O slot in the housing and tighten the top and bottom capture fasteners, but not too tight.



Figure 5-9. New I/O Module in Place Prior to Attaching Terminal Board and Terminal Housing Assembly

- 7.** Take the terminal block board and terminal housing assembly, with all the I/O wiring, that you removed in step 4, and line up its fasteners with the holes on the module, now seated in the housing, and gently push the terminal block board and terminal housing assembly into the module and tighten the fasteners.
- 8.** When the new board starts, and is functioning properly, return any processes you put into manual control to automatic control.

5.2.6 Removing/Replacing the Backup Battery

Note: For the backup battery to function, CPU switch SW3-4 must be ON. See *Section 2.4.1* for information on setting CPU module switches.

The CPU module includes a backup battery that sits in front of the PSSM module as you face the ControlWave I/O rack. The battery provides backup power for the real-time clock (RTC), CMOS RAM, and the system SRAM on the CPU module. The CPU module backup battery is a 3.6V, 950 mA-hr ½ AA lithium cell battery.

Note: The CPU module draws power from the battery only if the module loses power. The system SRAM has a standby current draw of 50 uA maximum for each part. For a ControlWave containing 2MB of SRAM, a worst-case current draw of 110 uA allows a battery life of approximately 8,636 hours. This means you should not need to replace a battery until the ControlWave has been in service for an extended period (normally many years).

 **Caution**

You lose SRAM contents when you remove the backup battery or its assembly from the CPU module.

If you replace a backup battery or its assembly, wait at least one minute before re-powering the system. This enables the SRAM to completely discharge.

**Removing /
Replacing the
Battery**

1. If the ControlWave I/O rack is running, place any critical control processes under manual control.
2. Remove the bezel that covers the PSSM and CPU modules.
3. Grasp the battery retaining clip and gently pull it up and away from the backup battery assembly to release the top of the retaining clip.
4. Pull the retaining clip down and outward to remove it.
5. Remove the battery. Wait at least one minute for SRAM to fully discharge.
6. Put in the replacement battery.
7. Snap the retaining clip back into place.
8. Put the bezel back in place.

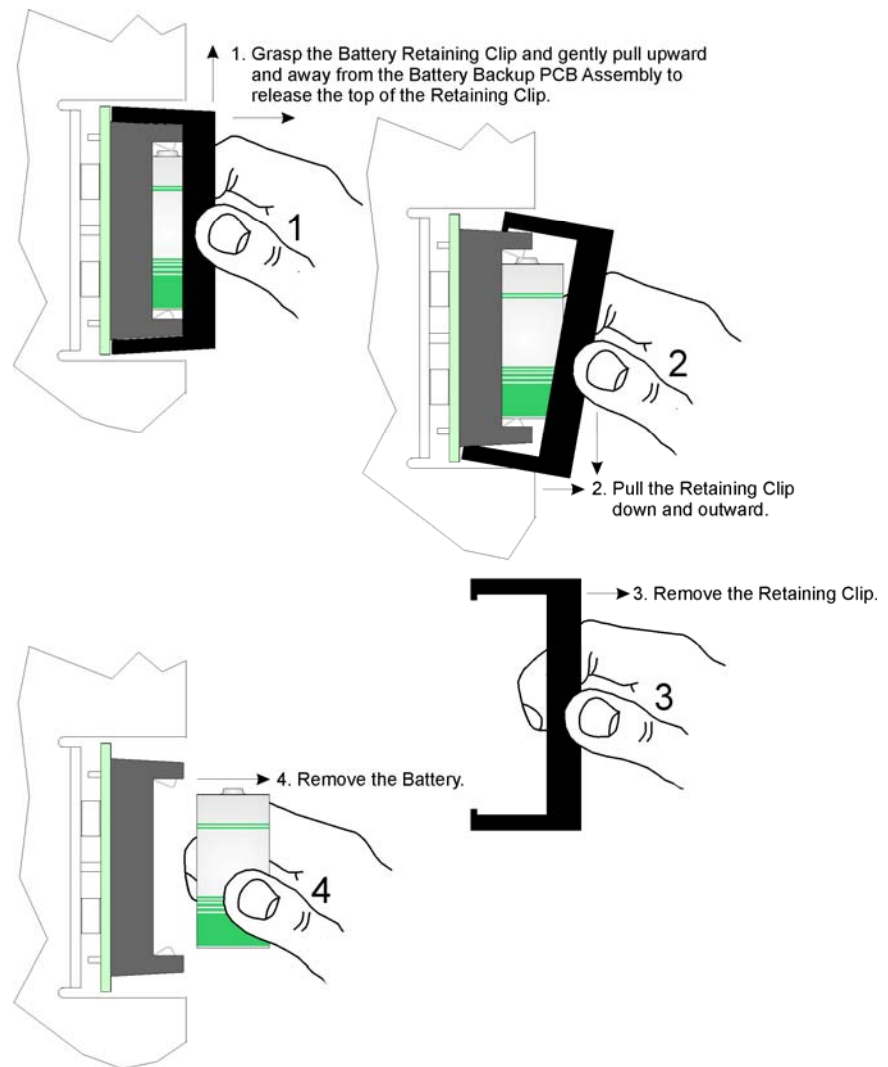

Figure 5-10. Lithium Backup Battery Removal Diagram

5.3 General Troubleshooting Procedures

This section presents some procedures to troubleshoot problems with the ControlWave I/O rack.

5.3.1 Common Communication Configuration Problems

If serial communications do not function, it is often due to one of the following issues:

- **Baud rate mismatch** – the baud rate at both ends of the communication line must match. If communications fail during a download of a new flash configuration profile (FCP) file, you may have changed the baud rate of the active communication line, since baud rate changes occur immediately on FCP download. You can always re-establish factory default baud rates for communication

ports by powering down the unit, and then setting CPU switch SW1-3 to **OFF** and restoring power.

- Incorrect BSAP local address – this address must be an integer from 1 to 127 and must be unique on this particular BSAP communication line. You set the BSAP local address using the flash configuration utility. If this ControlWave is a BSAP slave node, and the range of addresses defined for the BSAP master port end of the communication **line** does not encompass the local BSAP address defined for this ControlWave, BSAP communications will not function.
- Incorrect EBSAP Group number – if you use expanded BSAP the EBSAP group number must be correct; if you are not using EBSAP, the group number must be 0.

If IP communications do not function, it is often due to incorrect IP addresses or masks. Check to see that the IP address you defined for the ControlWave is compatible with the range of IP addresses defined for the communication line on which the unit resides. Also check that the IP address of the default gateway is correct.

5.3.2 Checking LEDs

ControlWave modules contain light emitting diodes (LEDs) that provide operational and diagnostic functions.

Table 5-1 shows LED assignments on modules.

Table 5-1. LED Assignments on Modules

Module / Board	LED Name	LED Color	Function and Location
PSSM	MC	Red	Lights when the CPU is not running, and I/O has been reset to 0. This lights momentarily when unit first powers on or when the unit resets. Master Clear; ON 2msec after PWR FAIL goes low. See <i>Figure 5-11</i> .
PSSM	PWR DOWN	Red	ON = Bulk or regulated power has fallen below acceptable levels. See <i>Figure 5-11</i> .
PSSM	PWR GOOD	Green	ON = Normal operation; all power supplies okay. See <i>Figure 5-11</i> . Each power supply on the PSSM also has its own LED which lights when power is good. If this LED does not light, remove the power supply and check the fuse. Then ensure that the board is fully inserted.
CPU	CR1 – WATCHDOG	Red	ON = Watchdog condition. See <i>Section 2.3.7</i> for a description of what causes a watchdog. See <i>Figure 5-12</i> .
CPU	CR2 – IDLE	Red	ON = CPU idle. The CPU should show idle most of the time. If this light goes OFF and

Module / Board	LED Name	LED Color	Function and Location
			stays OFF, the CPU is overloaded. See <i>Figure 5-12</i> .
CPU	CR3 – COMM 1 RX	Red	ON = RX (receive activity) on COMM1. See top-left of LED cluster in <i>Figure 5-12</i> .
CPU	CR3 – COMM 1 TX	Red	ON = TX (transmit activity) on COMM1. See top-right of LED cluster in <i>Figure 5-12</i> .
CPU	CR3 – COMM 2 RX	Red	ON = RX (receive activity) on COMM2. See bottom-left of LED cluster in <i>Figure 5-12</i> .
CPU	CR3 – COMM 2 TX	Red	ON = TX (transmit activity) on COMM2. See bottom-right of LED cluster in <i>Figure 5-12</i> .
CPU	CR8 – ENET Port 1	Red/Green	ON RED = Data Collision (Left – see <i>Figure 5-12</i> .)
CPU	CR8 – ENET Port 1	Red/Green	ON GREEN = Receiving data (Left – see <i>Figure 5-12</i> .)
CPU	CR8 – ENET Port 1	Red/Green	ON RED = Transmitting data (Right – see <i>Figure 5-12</i> .)
CPU	CR8 – ENET Port 1	Red/Green	ON GREEN = Link O.K. (Right – see <i>Figure 5-12</i> .)
SCB	CR2 – COMM 3 RX	Red	ON = RX (receive activity) on COMM3. See top-left of LED cluster in <i>Figure 5-12</i> .
SCB	CR2 – COMM 3 TX	Red	ON = TX (transmit activity) on COMM3. See top-right of LED cluster in <i>Figure 5-12</i> .
SCB	CR2 – COMM 4 RX	Red	ON = RX (receive activity) on COMM4. See bottom-left of LED cluster in <i>Figure 5-12</i> .
SCB	CR2 – COMM 4 TX	Red	ON = TX (transmit activity) on COMM4. See bottom-right of LED cluster in <i>Figure 5-12</i> .
SCB	CR4 – ENET Port 2	Red/Green	ON RED = Data Collision (Left – see <i>Figure 5-12</i> .)
SCB	CR4 – ENET Port 2	Red/Green	ON GREEN = Receiving data (Left – see <i>Figure 5-12</i> .)
SCB	CR4 – ENET Port 2	Red/Green	ON RED = Transmitting data (Right – see <i>Figure 5-12</i> .)
SCB	CR4 – ENET Port 2	Red/Green	ON GREEN = Link O.K. (Right – see <i>Figure 5-12</i> .)
SCB	CR5 – ENET Port 3	Red/Green	ON RED = Data Collision (Left – see <i>Figure 5-12</i> .)
SCB	CR5 – ENET Port 3	Red/Green	ON GREEN = Receiving data (Left – see <i>Figure 5-12</i> .)
SCB	CR5 – ENET Port 3	Red/Green	ON RED = Transmitting data (Right – see <i>Figure 5-12</i> .)
SCB	CR5 – ENET Port 3	Red/Green	ON GREEN = Link O.K. (Right – see <i>Figure 5-12</i> .)
CPU	PORT 80 DISPLAY	Red LEDs	LED Matrix displays status codes. See <i>Figure 5-12</i> . See <i>Table 5-3 & 5-4</i> .
AI	AI Board Status	Red/Green	ON RED = Fail state/ board not recognized ON GREEN = Normal state. See <i>Figure 5-13</i>

Module / Board	LED Name	LED Color	Function and Location
AI	Range (16 LEDs – one per point)	Red	LED ON = AI over-range or AI under-range condition. See <i>Figure 5-13</i>
AI	Range (16 LEDs – one per point)	Green	LED ON = AI in range. See <i>Figure 5-13</i>
AO	AO Board status fail	Red	LED ON = AO board fail state / board not recognized. See <i>Figure 5-14</i> .
AO	AO Board status pass	Green	LED ON = AO board normal or O.K. state. <i>Figure 5-14</i> .
DI	DI Board status	Red/Green	ON RED = DI board fail state; board not recognized. ON GREEN = DI board normal state. See <i>Figure 5-15</i> .
DI	DI board inputs (32 LEDs – 1 per point)	Red	LED ON = Input is present. LED OFF = Input is not present. See <i>Figure 5-15</i> .
DO	DO Board status	Red/Green	ON RED = DO board fail state; board not recognized. ON GREEN = DO board normal state. See <i>Figure 5-16</i> .
DO	DO board outputs (32 LEDs – 1 per point)	Red	LED ON = Output is ON. See <i>Figure 5-16</i> .
UDI	UDI Board Status Fail	Red	LED ON = UDI board fail state/board not recognized. See <i>Figure 5-17</i> .
UDI	UDI Board Status Pass	Green	LED ON = UDI board normal or O.K. state. See <i>Figure 5-17</i> .
UDI	UDI Input (12 LEDs – 1 per point)	Red	LED ON = UDI input activity. LED OFF = no UDI input activity. See <i>Figure 5-17</i> .
RTD	RTD Board Status	Red/Green	ON RED = Fail state/board not recognized. ON GREEN = Normal state. See <i>Figure 5-18</i> .
RTD	Range (8 LEDs – 1 per point)	Red	LED ON = RTD over-range or RTD under-range condition. See <i>Figure 5-18</i> .
RTD	Range (8 LEDs – 1 per point)	Green	LED ON = RTD in range. See <i>Figure 5-18</i> .
TC	LLAI Board Status	Red/Green	ON RED = Fail state/board not recognized. ON GREEN = Normal state. See <i>Figure 5-19</i> .
TC	Range (12 LEDs – 1 per point)	Red	LED ON = LLAI over-range or LLAI under-range condition. See <i>Figure 5-19</i> .
TC	Range (12 LEDs – 1 per point)	Green	LED ON = LLAI in range. See <i>Figure 5-19</i> .

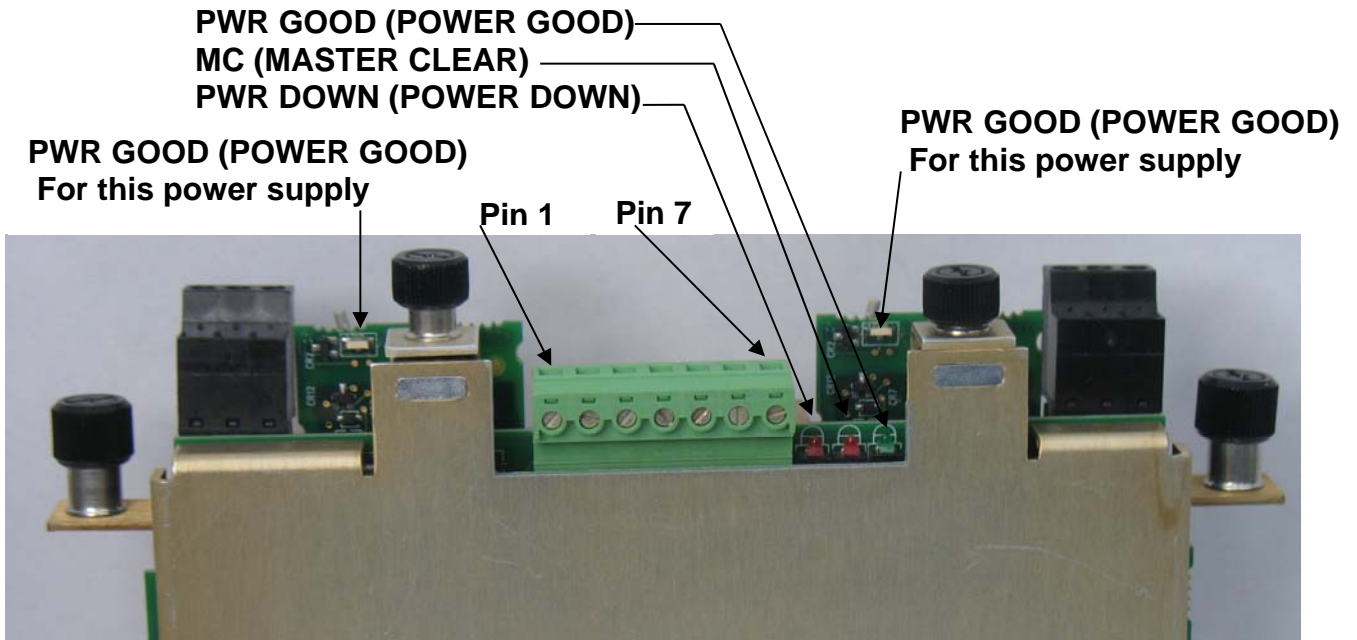

Figure 5-11. PSSM LED Locations

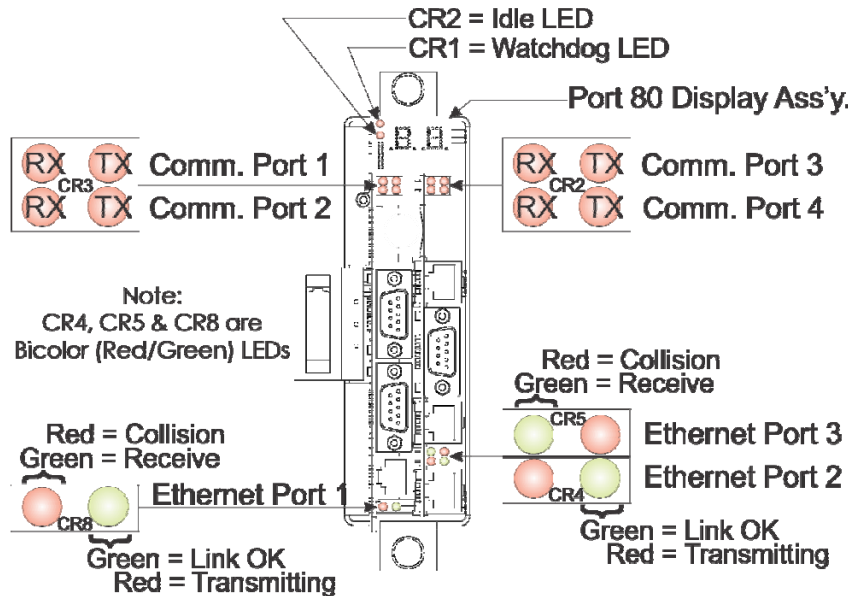
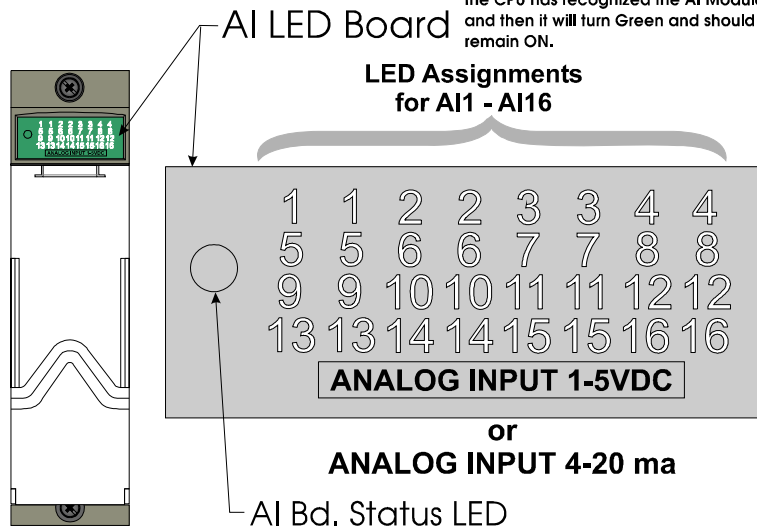

Figure 5-12. CPU Module (CPU & SCB boards) Port & LED Designations

Red AI Bd. Status LED = AI Bd. not recognized or failed.
 Green AI Bd. Status LED = AI Bd. recognized and normal.
 Red AIXX = Overrange/Underrange condition.
 Green AIXX = In-range condition.

Note: The Status LED will turn ON (Red) whenever power is initially applied to the AI Module. It will remain Red until the CPU has recognized the AI Module and then it will turn Green and should remain ON.



Note: Open Inputs default to an underrange condition

Figure 5-13. Analog Input (AI) Module LED Designations

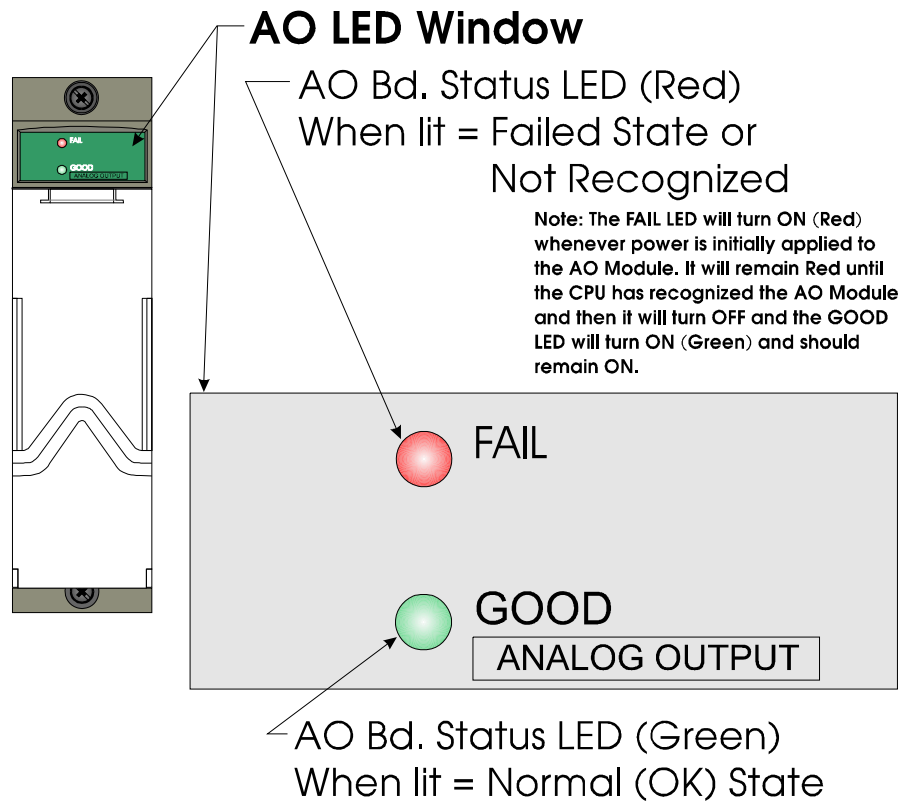

Figure 5-14. Analog Output (AO) Module LED Designations

Red DI Bd. Status LED = DI Bd. not recognized or failed.
 Green DI Bd. Status LED = DI Bd. recognized and normal.
 Red DIXX = Input is present.
 OFF DIXX = Input is not present.

Note: The Status LED will turn ON (Red) whenever power is initially applied to the DI Module. It will remain Red until the CPU has recognized the DI Module and then it will turn Green and should remain ON.

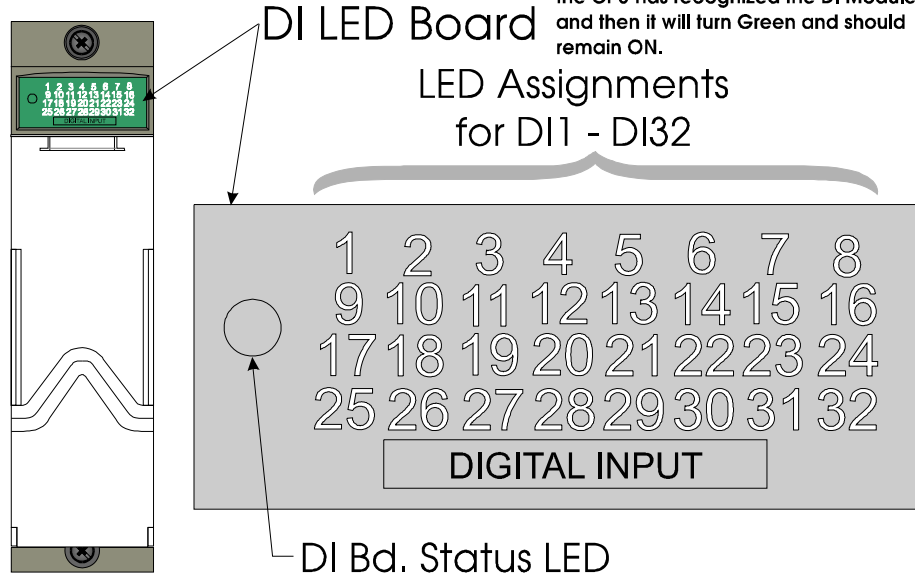

Figure 5-15. Digital Input (DI) Module LED Designations

Red DO Bd. status LED = DO Bd. not recognized or failed.
 Green DO Bd. status LED = DO Bd. recognized and normal.
 Red DOXX = Output is ON.

Note: The Status LED will turn ON (Red) whenever power is initially applied to the DO Module. It will remain Red until the CPU has recognized the DO Module and then it will turn Green and should remain ON.

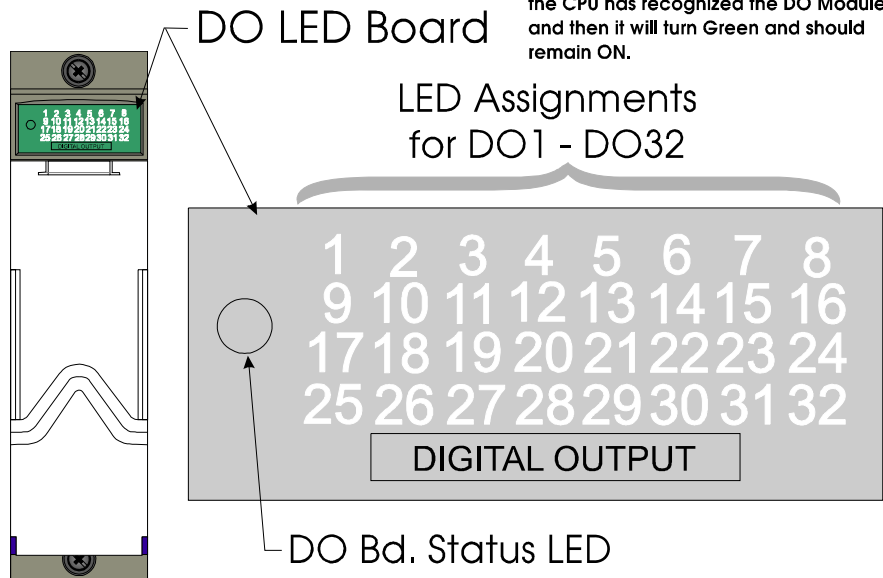

Figure 5-16. Digital Output (DO) Module LED Designations

UDI Bd. Status LED (Red) = UDI Bd. not recognized or failed.
UDI Bd. Status LED (Green) = UDI Bd. recognized and normal.
ON UDIXX = Input is present.
OFF UDIXX = Input is not present.

Note: The Status LED will turn ON (Red) whenever power is initially applied to the UDI Module. It will remain Red until the CPU has recognized the UDI Module and then it will turn Green and should remain ON.

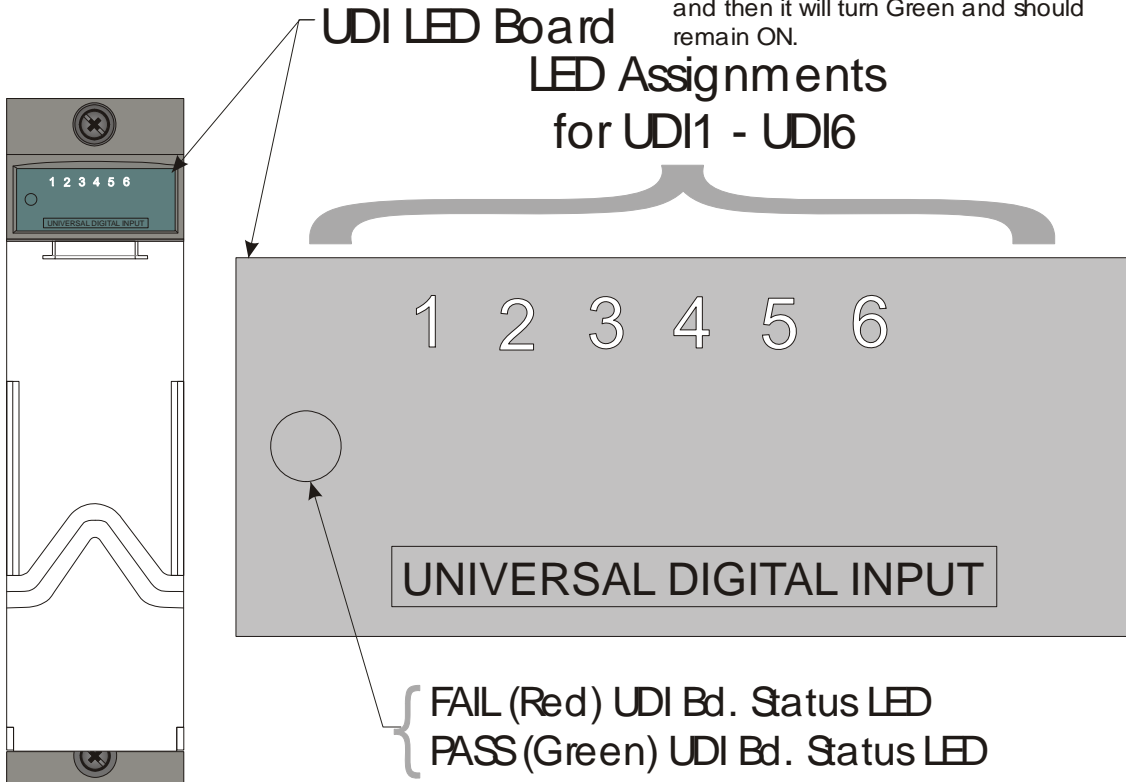
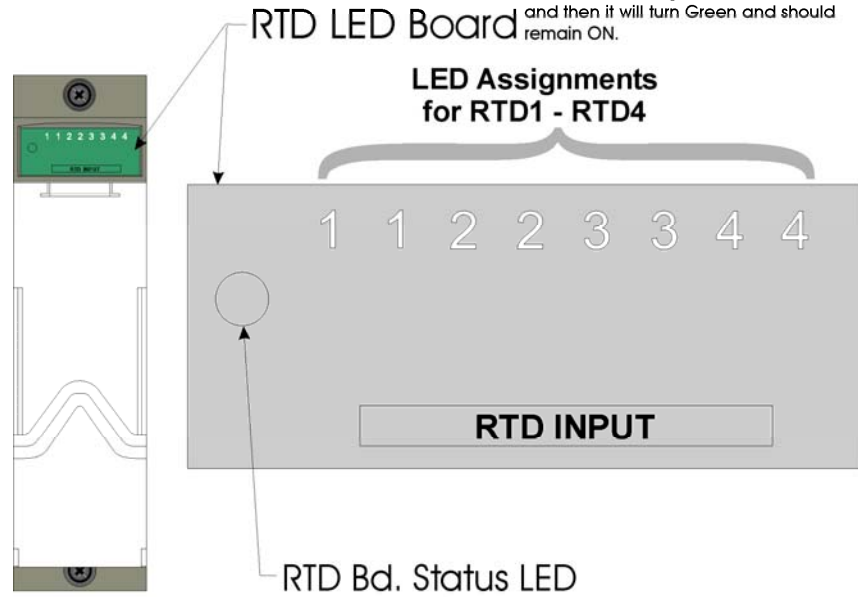

Figure 5-17. Universal Digital Input (UDI) Module LED Designations

Red RTD Bd. Status LED = RTD Bd. not recognized or failed.
 Green RTD Bd. Status LED = RTD Bd. recognized and normal.
 Red RTDXX = Overrange/Underrange condition.
 Green RTDXX = In-range condition.

Note: The Status LED will turn ON (Red) whenever power is initially applied to the RTD Module. It will remain Red until the CPU has recognized the RTD Module and then it will turn Green and should remain ON.



Note: Open Inputs default to an underrange condition

Figure 5-18. RTD Module LED Designations

Red LLAI Bd. Status LED = LLAI Bd. not recognized or failed.
 Green LLAI Bd. Status LED = LLAI Bd. recognized and normal.
 Red LLAIXX = Overrange/Underrange condition.
 Green LLAIXX = In-range condition.

Note: The Status LED will turn ON (Red) whenever power is initially applied to the LLAI Module. It will remain Red until the CPU has recognized the LLAI Module and then it will turn Green and should remain ON.

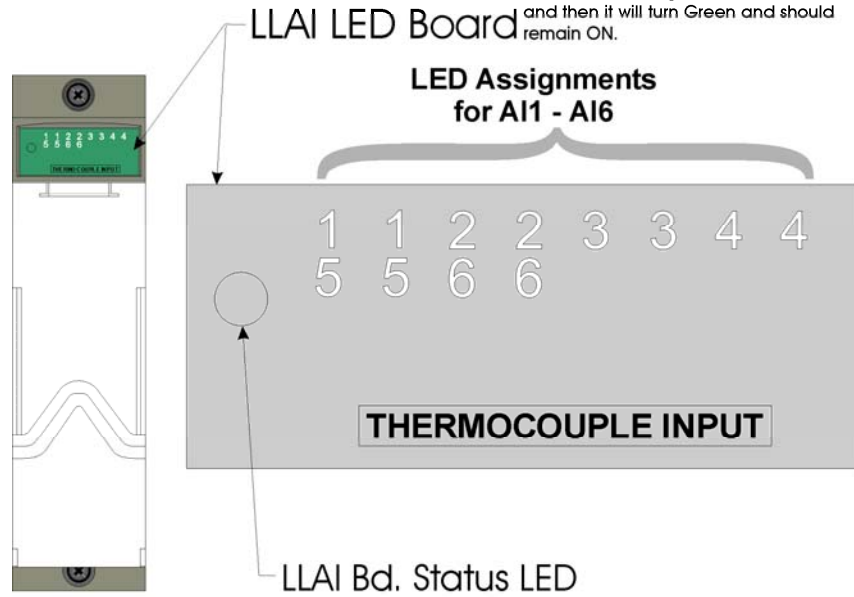

Note: Open Inputs default to an underrange condition

Figure 5-19. Thermocouple Module LED Designations

5.3.3 Checking Wiring/Signals

Check I/O field wiring at the terminal blocks and at the field device. Inspect the wiring for continuity, shorts, and opens. Check I/O signals at their respective terminal blocks (see *Table 5-2*).

Table 5-2. I/O Field Wiring - Terminal Block Reference

I/O Module or sub-system	Notes
Digital Input Modules	See Section 3.4
Digital Output Modules	See Section 3.5
Analog Input Modules	See Section 3.6
Analog Output Modules	See Section 3.7
Universal Digital Input (UDI) Modules	See Section 3.8
RTD Input Modules	See Section 3.9
Thermocouple Modules	See Section 3.10
Watchdog Circuit	See Section 2.3.5

5.3.4 Port 80 Display Codes

The Port 80 Display shows two different types of codes. POST codes, and run-time status codes.

Power-On-Self-Test (POST) Codes

When you first power up the ControlWave I/O rack, or if you reset it using the reset switch, the BIOS runs a power-on-self-test (POST) to test the hardware. Normally, the POST codes pass by too quickly for you to see them, and the system enters normal run time, or if the CPU is set for force recovery mode, you see the code “86.” If there is a fault during the POST process, see *Table 5-3* for the 2-digit failure code.

Table 5-3. Port 80 POST Status Codes

HEX Code	Definition
00	POST beginning.
01	CPU register test about to start.
02	NMIs are disabled; delay starts.
03	power-on delay finished.
04	kbd BAT done; reading kbd SYS bit.
05	disabling shadowing & cache.
06	calcining ROM cksum, wait kbd ctrllr.
07	cksum okay, kbd ctrllr free.
08	verifying BAT cmd to kbd ctrllr.
09	N/A
0A	N/A
0B	issuing pin 23, 24 blocking & unblocking.
0C	issuing kbd ctrllr NOP cmd next.
0D	testing CMOS RAM shutdown register.
0E	checking CMOS cksum, updating DIAG byte.
0F	initializing CMOS (if req'd every boot).
10	Init. CMOS status reg. for date/time.
11	disabling DMA, interrupt ctrllrs.
12	disabling Port B, disabling video display.
13	Init. board, start auto-mem detect.
14	starting timer tests.
15	testing 8254 T2, for spkr, part B.
16	testing 8254 T1, for refresh.
17	testing 8254 To, for 18.2 Hz.
18	starting memory refresh.
19	testing memory refresh.
1A	testing 15usec refresh ON/OFF time.
1B	testing base 64KB memory.
1C	testing data lines.
20	testing address lines.
21	testing parity (toggling).
22	base 64KB mem read/write test.
23	system init before vector table init.
24	init vector table.
25	reading 8042 for turbo switch setting.
26	initiating turbo data.
27	any init after vector table init is next.
28	N/A
29	N/A
2A	toggle parity before optional video ROM.
2B	N/A

HEX Code	Definition
2C	N/A
2D	N/A
2E	N/A
2F	N/A
30	N/A
31	N/A
32	N/A
33	N/A
34	N/A
35	check ROM BIOS data area at seg 40h.
36	setting cursor for power-on msg.
37	displaying power-on message.
38	save cursor position.
39	display BIOS ident. String.
3A	display "Hit to ..." msg.
40	preparing vm test. vrfy from display.
41	preparing descriptor tables.
42	enter virtual mode for memory test.
43	enable inits for diagnostics mode.
44	init data for checking wraparound at 0:0.
45	checking for wrap, find total memory size.
46	write extended memory test patterns.
47	write conventional memory test patterns.
48	finding low memory size from patterns.
49	finding high memory size from patterns.
4A	check ROM BIOS data area again.
4B	check for , clear low mem for soft reset.
4C	clearing ext mem for soft reset.
4D	saving memory size.
4E	on cold boot, display 1 st 64KB memtest.
4F	on cold boot, test all of low memory.
50	adjust memsize for 1K usage.
51	On cold boot, test high memory
52	prepare for shutdown to real-mode.
53	saved regs & memsize, entering real-mode.
54	shutdown successful, restoring codepath.
55	disabling A20 line.
56	checking ROM BIOS data area again.
57	checking ROM BIOS data area some more.
58	clear the "Hit " message.
59	test DMA page register.
60	verify from display memory (???)
61	test DMA0 base register.
62	test DMA1 base register.
63	checking ROM BIOS data area again.
64	checking ROM BIOS data area some more.
65	programming DMA ctrllrs 0 & 1
66	initializing INT ctrllrs 0 & 1.
67	N/A
80	N/A
81	N/A
82	N/A
83	N/A
84	check for memsize mismatch.
85	check for pswd or bypass setup.

HEX Code	Definition
86	pswd checked. Do pgming before setup.
87	call the setup module.
88	N/A
89	display power-on screen message.
8A	display "Wait..." message.
8B	N/A
8C	N/A
8D	N/A
8E	check floppy disks.
8F	N/A
90	N/A
91	N/A
92	N/A
93	N/A
94	setting base & ext mem sizes.
95	N/A
96	N/A
97	N/A
98	processing after extension returns.
99	configuring timer data area, printer base addr.
9A	configuring serial port base addrs.
9B	initialization before coprocessor test.
9C	initializing the coprocessor.
9D	processing after coprocessor initialized.
9E	N/A
9F	N/A
A0	kbd ID flag reset.
A1	do cache memory test.
A2	display any soft errors.
A3	N/A
A4	program memory wait states.
A5	N/A
A6	enable parity and NMIs.
A7	N/A
A8	N/A
A9	N/A
B0	N/A
B1	test low memory exhaustively.
B2	test extended memory exhaustively.
B3	N/A

Run Time Status Codes Once your ControlWave I/O rack is normally running, the Port 80 display is usually blank to conserve power. *Table 5-4* shows status codes you may see during run-time.

Table 5-4. Port 80 Run Time Status Codes

HEX Code	Definition	Notes
00	No Application	
1D	Currently Loading the Boot Project	
51	System Initialization in Progress	
86	Recovery Mode	SW3-3 = ON; Not an actual

HEX Code	Definition	Notes
		running status code; SW3-3 should be OFF.
D0	Diagnostic Mode	SW1-8 =OFF
D1	Running Diagnostic	
F0	NPX Error	Unit Stopped
FE	FLASH Programming Error	
5E	System Start Error	
BF	Battery Fail	Check SW3-4
CA	Hot Card Replacement in Progress	
CF	Invalid Checksum Detected	Unit Stopped
FA	CPU board switch SW1-3 Set OFF Ignore Soft Switch Configuration – Use Factory Defaults	Flashes for 1 second at startup
FD	Waiting for Updump	Core Dump in process or waiting to start
FF	Unit Crashed	Unit Stopped
FC	Waiting for Alt. Watchdog Timer	Unit Stopped

5.3.5 Reset Switch

The reset switch (SW4) is a momentary button that lets you reset (stop and restart) the ControlWave while you test the unit using WINDIAG diagnostic software.

 **Caution** Never use the reset switch during normal operation.

5.4 WINDIAG Diagnostic Utility

WINDIAG is a software-based diagnostic tool you use to test the performance of I/O modules, CPU memory, communication ports, and other system components. .

WINDIAG is a PC-based program, so the ControlWave I/O rack must be attached to and communicating with a PC running WINDIAG. Set configuration switch SW1-8 **OFF** (closed) on the CPU module to enable the diagnostic routines.

Establish communication between the ControlWave I/O rack and the PC with a local or network port under the following conditions:

- Turn CPU module switches SW1-3 and SW1-8 **OFF** to run the WINDIAG program. Setting SW1- places the ControlWave in diagnostic mode. Setting SW1-3 off causes the ControlWave to ignore soft switch settings and use factory defaults; this sets all serial ports to 9600 baud in preparation for the diagnostic tests.
- Use a null modem cable to connect RS-232 ports between the ControlWave and the PC. Use an RS-485 cable to connect the RS-485 ports of the ControlWave and the PC.

Note: For information on port connections and cabling, please see *Chapter 2*. See *Section 4.3.1* for information on communication port defaults.

- Reserve the port running a diagnostic test for exclusive use; you cannot use that port for any other purpose during testing.

Before starting the WINDIAG program, place any critical processes the ControlWave I/O expansion rack is handling under manual control. You cannot run WINDIAG while the ControlWave I/O rack is controlling I/O. Set the CPU modules switches SW1-3 and SW1-8 to **OFF**, and perform the following steps:

- Start the NetView program in OpenBSI with your current network NETDEF file. A menu displays (similar to the one in *Figure 5-20*):

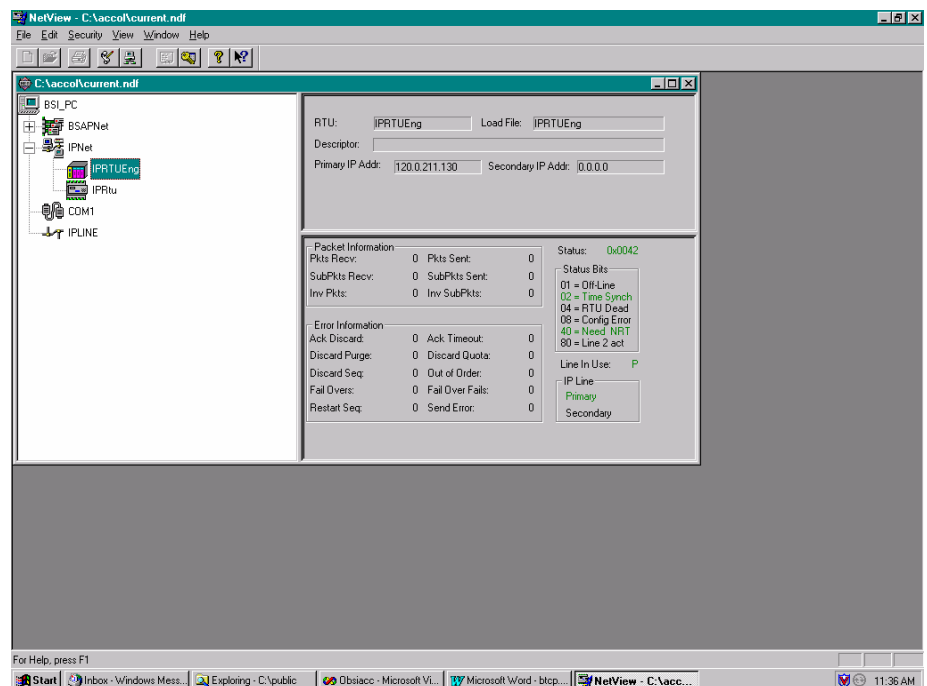

Figure 5-20. NetView

- Select **Start >Programs > OpenBSI Tools >Common Tools >Diagnostics**. The Main Diagnostics menu (*Figure 5-21*) displays.

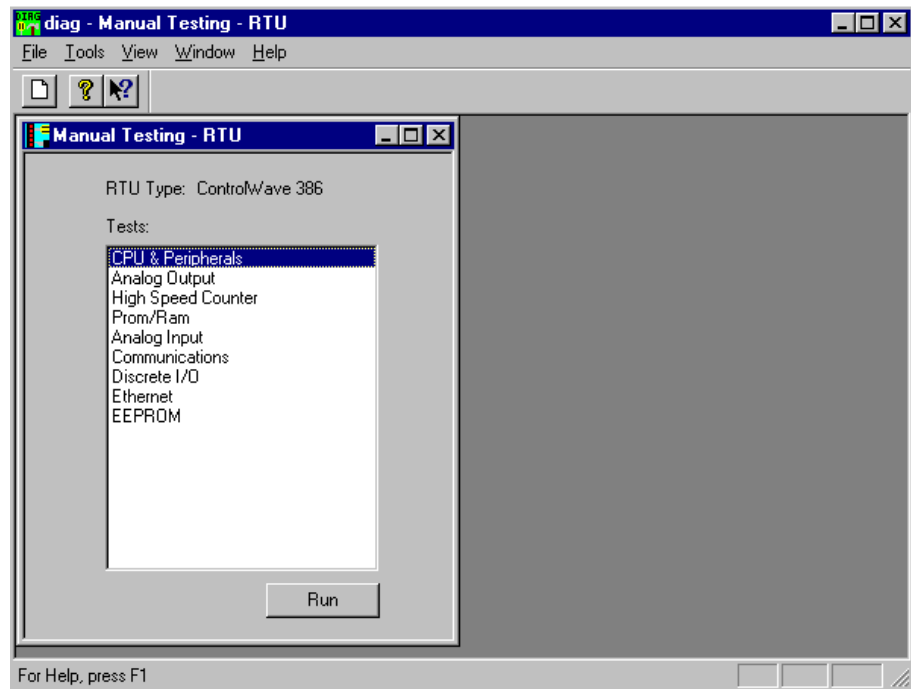

Figure 5-21. WINDIAG Main Diagnostics Menu

3. Select the module to be tested. Enter any prompted parameters (slot #, etc.). WINDIAG performs the diagnostics and displays pass/fail results.
4. After performing all diagnostic testing, exit WINDIAG and then exit the NetView if you don't have any other ControlWave units to test.

When you close NetView, the system asks whether you want to close OpenBSI. Select **Yes**.

5. Set switch SW1-8 on the CPU module to **ON** (open). The ControlWave should resume normal operation.

5.4.1 Available Diagnostics

Using WINDIAG, you can test all ControlWave modules with the exception of the PSSM. WINDIAG's Main Diagnostics Menu (see Figure 5-21) provides the following diagnostic selections:

Option	Tests
CPU & Peripherals	Checks the CPU module (except for RAM & PROM).
Analog Output	Checks AOs on the Analog Output module.
High Speed Counter	Checks the Universal Digital Input (UDI) module.
Prom/Ram	Checks the CPU's RAM and PROM hardware.
Analog Input	Checks AIs on the Analog Input module.
Communications	Checks Communication ports. The loop-back tests require the use of a loop-back plug.

Option	Tests
Discrete I/O	Checks DIs on Digital Input Module, DOs on Digital Output Modules.
Ethernet	Checks Ethernet Ports. The loop-back tests require the use of a loop-back plug.

Port Loop-back Test

WINDIAG allows you to select the communication port (1 through 4) to test. Depending on the type of network (RS-232 or RS-485) and the port in question, a special loop-back plug is required:

- Ports 1, 2, and 4 (RS-232) use a 9-pin female D-type loop-back plug (shown in *Figure 5-22*).

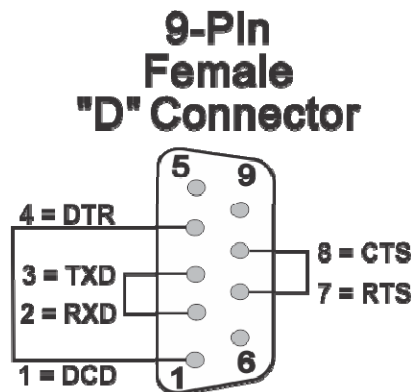

Figure 5-22. RS-232 Loop-back Plug

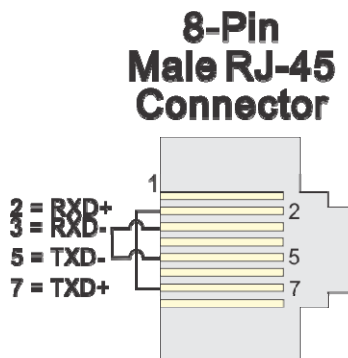

Figure 5-23. RS-485 Loop-back Plug

- Port 3 (RS-485) uses an 8-pin male RJ-45 loop-back plug (shown in *Figure 5-23*).

These tests verify the correct operation of the communication interface on ports COM1 through COM4.

Note: You **cannot** test a communications port while you are using it. You can only test currently unused ports. After you complete testing on all other communication ports (and verify their correct functioning), you must reconnect (using a now validated port) and test the remaining untested port.

Test Procedure Use this procedure to test the comm ports.

1. Connect an external loop-back plug to the port on the CPU or SCB port you want to test. Valid ports are:
 - J2 of CPU board for COM1
 - J3 of CPU board for COM2
 - J2 of SCB board for COM3
 - J3 of SCB board for COM4
2. Select **Communications** on the WINDIAG Main Diagnostics Menu. The Communications Diagnostic screen opens:

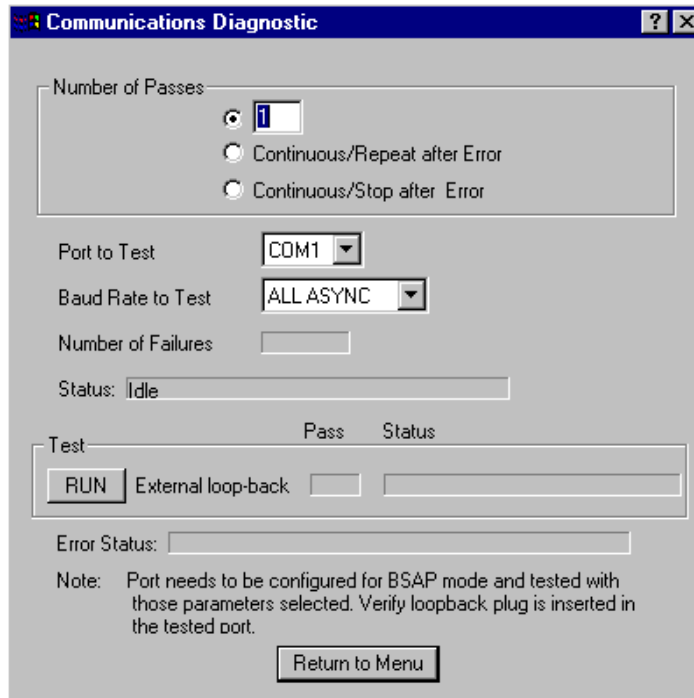

Figure 5-24. Communications Diagnostic Menu

3. Enter **5** in the Number of Passes field.
4. Select a port to test (click ▼ to display all available ports).

Note: The port you select must correlate to the port on which you placed the loop-back plug in step 1.
5. Select **115200** or **ALL ASYNC** as the baud rate (click ▼ to display all available rates).
6. Click **RUN** to start the test. At the completion of the test (which generally takes about 5 seconds), any failed results appear in the Status field to the right of the RUN button:
 - TXD RXD Failure
 - CTS RTS Failure
7. Click **Return to Menu** to display the WINDIAG Main Menu.

Ethernet Port Loop-back Test

The **Ethernet** option on the WINDIAG Main Menu allows you to select the Ethernet communication port (1 through 3) to test.

This test configures the Ethernet port's ability to transmit and receive via the twisted pair. The test transmits frames and compares them against received frames. You need a special loop-back plug (shown in *Figure 5-25*) to perform the Ethernet loop-back test:

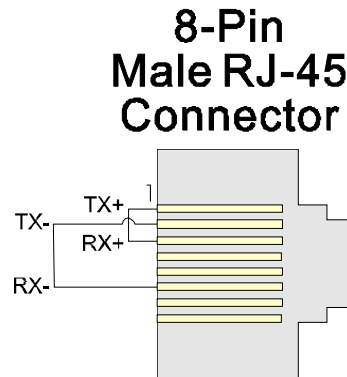

Figure 5-25. RJ-45 Ethernet Loop-back Plug

Note: You **cannot** test a communications port while you are using it. You can only test currently unused ports. After you complete testing on all other communication ports (and verify their correct functioning), you must reconnect (using a now validated port) and test the remaining untested port.

Test Procedure

Use this procedure to test the Ethernet port.

1. Connect an external Ethernet loop-back plug (see *Figure 5-25*) to the Ethernet port on the CPU module to be tested.
2. Select **Ethernet** on the WINDIAG Main Diagnostics Menu. The Ethernet Diagnostic screen opens:

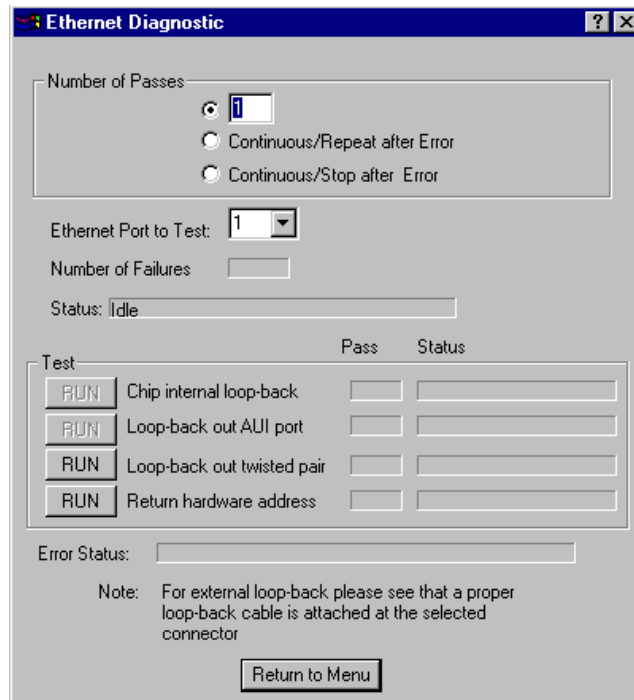

Figure 5-26. Ethernet Diagnostic Menu

3. Enter **1** in the Number of Passes field.
4. Enter **1**, **2**, or **3** in the Ethernet Port to Test field.
5. Click **RUN** next to the Loop-back out twisted pair field to start the test. At the completion of the test, any failed results appear in the Status field next to the **Loop-back out twisted pair** label:
6. Disconnect the loop-back plug and reconnect the Ethernet cable to the ControlWave and the Ethernet hub.
7. Click **Return to Menu** to display the WINDIAG Main Menu.

5.5 Core Updump

In some cases—such as when a ControlWave I/O rack fails for no apparent reason—you can upload a copy of the contents of SRAM and SDRAM to a PC for support personnel and service engineers to evaluate. This upload is called a “core updump.”

A core updump may be required if the ControlWave spontaneously enters a watchdog state that affects all system operation. This occurs when the system crashes as a result of a CPU timeout (resulting from improper software operation, a firmware glitch, and so on). In some cases, the watchdog state can recur but you cannot logically reproduce the conditions.

The CPU module’s RAM contains “crash blocks,” a firmware function provided specifically for watchdog troubleshooting. You can view and save the crash blocks by viewing the Crash Block Statistic Web Page

(see the *Web_BSI Manual*, D5087). On request, you can forward crash block files to our technical support personnel. If they need additional information to evaluate the condition, the technical support group may request a core updump. Once the core updump process generates a file, you can forward that file to the support personnel for evaluation and resolution.

Use the following steps to preserve the “failed state” condition at a system crash and perform a core updump:

1. Set switch SW1-1 on the CPU module to **OFF** (Disable Watchdog Timer). Set switch SW1-4 to **OFF** (Enable Core Updump).
2. Wait for the error condition (typically FF on the Port 80 display).
3. Connect the ControlWave Comm Port 1 to a PC using a null modem cable.
4. Start the PC’s HyperTerminal program (at 115.2 kbaud) and generate a receive using the 1KX-Modem protocol. Save the resulting core updump in a file so you can forward it later to the technical support group.

By setting the CPU module switches SW1-1 and SW1-4 both off **before** the ControlWave I/O rack fails, you prevent the ControlWave I/O rack from automatically recovering from the failure and enable it to wait for you to take a core updump.

Once you complete the core updump, set the CPU module’s switch SW1-1 to **ON** (Watchdog Enabled) and SW1-4 to **ON** (Normal Run).

With these switches set, power up the ControlWave I/O rack and recommence standard operations.

This page is intentionally left blank

Appendix A – ControlWave I/O Expansion Rack – Special Instructions for Class I, Division 2 Hazardous Locations.

1. The ControlWave I/O Expansion Rack is listed by Underwriters Laboratories (UL) as nonincendive and is suitable for use in Class I, Division 2, Groups A, B, C and D hazardous locations and non-hazardous locations only. Read this appendix carefully before installing a nonincendive ControlWave I/O Expansion Rack. In the event of a conflict between the main body of this manual and this appendix, always follow the instructions in this appendix.
2. All power and I/O wiring must be performed in accordance with Class I, Division 2 wiring methods as defined in Article 501-4 (b) of the National Electrical Code, NFPA 70, for installations within the United States, or as specified in Section 18-152 of the Canadian Electrical Code for installation in Canada.

**WARNING****EXPLOSION HAZARD**

Substitution of components may impair suitability for use in Class I, Division 2 environments.

**WARNING****EXPLOSION HAZARD**

When situated in a hazardous location, turn off power before servicing / replacing the unit and before installing or removing I/O wiring.

**WARNING****EXPLOSION HAZARD**

Do NOT disconnect equipment unless the power has been switched off or the area is known to be non-hazardous.

This page is intentionally left blank

Appendix B – Open MODBUS Interface

The Open Modbus Interface allows access to areas of memory in the I/O expansion rack serving as Modbus registers and coils.

In order to determine which coil / register addresses to reference in your Modbus commands, please refer to the tables on the following pages.

Notes:

- By default, registers are transmitted upper byte or upper word (upper byte within a word) first.
 - If, because of the requirements of your protocol, or device, you need to change the order of transmission, please follow the instructions at the end of this appendix.
 - For information on internal mapping of particular I/O modules, see the *I/O Mapping* section of the *ControlWave Designer Programmer's Handbook*.
-

B.1 Supported Devices

The following hardware platforms support this interface:

- ControlWave Process Automation Controller (PAC) with ControlWave I/O Expansion Rack
- ControlWave Redundant Controller (CWRED) with ControlWave I/O Expansion Rack
- ControlWave Redundant I/O Switcher (CW RED I/O) with ControlWave I/O Expansion Racks
- ControlWave Micro (CWM) Process Automation Controller with Distributed I/O System
- ControlWave CW_10, CW_30, or CW_35 controller with CW_31 Remote I/O Rack

B.2 Determining the Correct I/O Slot

If you have a host ControlWave device and an I/O rack, the I/O rack's slots are treated as slots numbered consecutively from the maximum host I/O slot number. So to reference I/O slots in the I/O rack, add the maximum host I/O slot number to the I/O slot number in the I/O rack.

For example, if you have a ControlWave host controller with eight (8) I/O slots that has an attached I/O expansion rack with four (4) I/O slots, for Modbus addressing purposes you reference the I/O expansion rack I/O slots as slots 9, 10, 11, and 12. (See *Figure B-1*.)

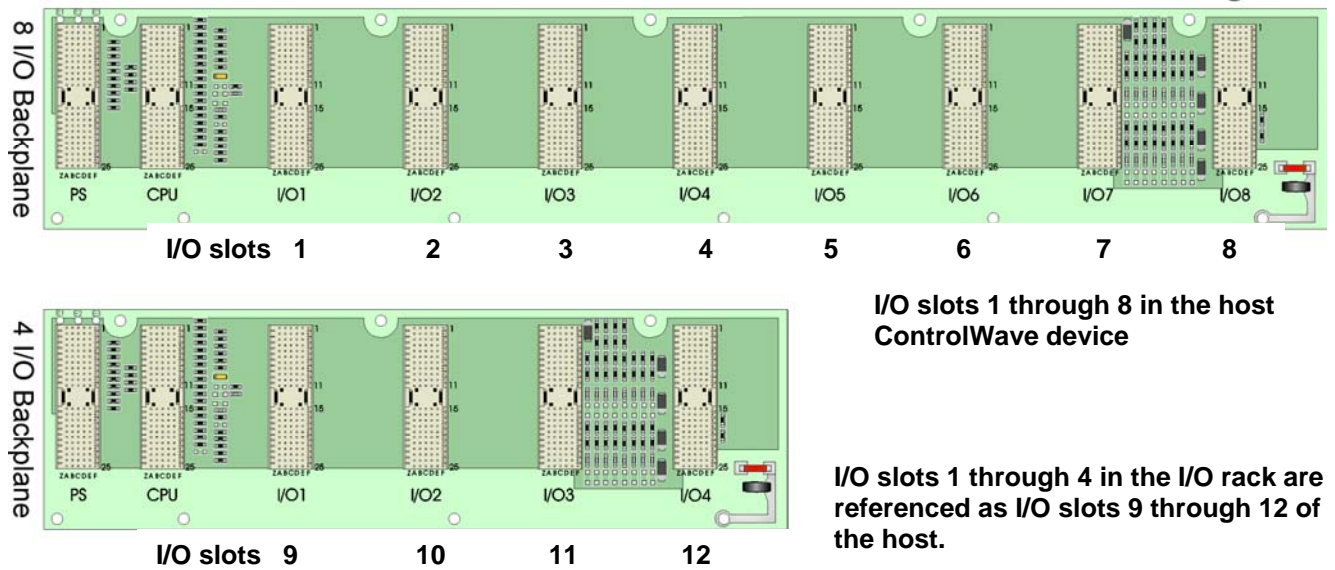

Figure B-1. Referencing I/O Slots Outside the Host

Notes:

- I/O racks that are part of a redundant pair share the same slot numbers.
- The address tables cover slot numbers up through 14. If you have multiple non-redundant I/O racks attached to the same host ControlWave, use consecutive I/O slot numbers for each successive rack, as if it was the part of the host ControlWave. Mapping addresses follow the same pattern for the higher slots.

B.3 Addressing for MODBUS Coils and Registers

B.3.1 System Data

Range: 1-100

I/O Slot	Board Status	Hot Card Replacement in Progress	Battery Status	Board Type Register (2 byte – transmitted upper byte first)
1	1	17	18	1
2	2	17	18	2
3	3	17	18	3
4	4	17	18	4
5	5	17	18	5
6	6	17	18	6
7	7	17	18	7
8	8	17	18	8
9	9	17	18	9

I/O Slot	Board Status	Hot Card Replacement in Progress	Battery Status	Board Type Register (2 byte – transmitted upper byte first)
10	10	17	18	10
11	11	17	18	11
12	12	17	18	12
13	13	17	18	13
14	14	17	18	14

B.3.2 Digital Data

Range: 101-420 (40 per board)

Example: To read DO output coil 5 on board 7, find DO output coils in the first row of the table, below, then move down that column until you reach the board 7 row to determine the range of DO output coil numbers for that board, in this case (341-372). The fifth coil in the range 341 to 372 would be 345, so your Modbus command should request coil 345.

I/O Slot	Board Status (all)	DO Readback Status (1-32)	DI Value Coils (1-32)	DO Output Coils (1-32)
1 (101-140)	140	101-132	101-132	101-132
2 (141-180)	180	141-172	141-172	141-172
3 (181-220)	220	181-212	181-212	181-212
4 (221-260)	260	221-252	221-252	221-252
5 (261-300)	300	261-292	261-292	261-292
6 (301-340)	340	301-332	301-332	301-332
7 (341-380)	380	341-372	341-372	341-372
8 (381-420)	420	381-412	381-412	381-412
9 (421-460)	460	421-452	421-452	421-452
10 (461-500)	500	461-492	461-492	461-492
11 (501-540)	540	501-532	501-532	501-532
12 (541-580)	580	541-572	541-572	541-572
13 (581-620)	620	581-612	581-612	581-612
14 (621-66)	660	621-652	621-652	621-652

I/O Slot	AI, AO Out of Range Status (1-16 or 1-8)	AI, AO Conversion Error Status (39)	HSC Input State Status (1-12)	AO Fail to State Status (9-32) Coils (9-32) (3 sets of 8) *See Note 1	HSC Reset Coils (1-12)	HSC Setup Status 13-36 Coils 13-36 (2 sets of 12)
1 (101-140)	101-116 or 101-108	139	101-112	109-132	101-112	113-136
2 (141-180)	141-156 or 141-148	179	141-152	149-172	141-152	153-176
3 (181-220)	181-196 or 181-188	219	181-192	189-212	181-192	193-216
4 (221-260)	221-236 or 221-228	259	221-232	229-252	221-232	233-256
5 (261-300)	261-276 or 261-268	299	261-272	269- 292	261-272	273-296
6 (301-340)	301-316 or 301-308	339	301-312	309-332	301-312	313-336
7 (341-380)	341-356 or 341-348	379	341-352	349-372	341-352	353-376
8 (381-420)	381-396 or 381-388	419	381-392	389-412	381-392	393-416
9 (421-460)	421-436 or 421-428	459	421-432	429-452	421-432	433-456
10 (461-500)	461-476 or 461-468	499	461-472	469-492	461-472	473-496
11 (501-540)	501-516 or 501-508	539	501-512	509-532	501-512	513-536
12 (541-580)	541-556 or 541-548	579	541-552	549-572	541-552	553-576
13 (581-620)	581-596 or 581-588	619	581-592	589-612	581-592	593-616
14 (621-660)	621-636 or 621-628	659	621-632	629-652	621-632	633-656

** Note 1: First group must be set to 1 to have 2nd two groups written to board. Also, first group will always read as 0 - cleared as soon as written.*

B.3.3 Input Registers (2 byte signed registers, transmitted upper byte first)

Range: 101-260 (20 per board)

Example: To read AI register 8 on board 2, find AI value register in the first row of the table, below, then move down that column until you reach the board 2 row to determine the range of AI value register numbers, for that board, in this case (121-136). The eighth coil in the

range 121 to 136 would be 128, so your Modbus command should request register 128.

I/O Slot	AI value register (1-16)	AO clamped value register (1-8)	HSC lower 16 bits (1-12)
1 (101-120)	101-116	101-108	101-112
2 (121-140)	121-136	121-128	121-132
3 (141-160)	141-156	141-148	141-152
4 (161-180)	161-176	161-168	161-172
5 (181-200)	181-196	181-188	181-192
6 (201-220)	201-216	201-208	201-212
7 (221-240)	221-236	221-228	221-232
8 (241-260)	241-256	241-248	241-252
9 (261-280)	261-276	261-268	261-272
10 (281-300)	281-296	281-288	281-292
11 (301-320)	301-316	301-308	301-312
12 (321-340)	321-336	321-328	321-332
13 (341-360)	341-356	341-348	341-352
14 (361-380)	361-376	361-368	361-372

B.3.4 Output Registers (2 byte signed registers, transmitted upper byte first)

Range: 501-660 (20 per board)

Example: To read AO register 7 on board 5, find AO value register in the second column of the table, below, then move down that column until you reach the board 5 row to determine the range of AO value register numbers, for that board, in this case (581-588). The seventh coil in the range 581 to 588 would be 587, so your Modbus command should request register 587.

I/O Slot	AO value register (1-8)
1 (501-520)	501-508
2 (521-540)	521-528
3 (541-560)	541-548
4 (561-580)	561-568
5 (581-600)	581-588
6 (601-620)	601-608
7 (621-640)	621-628
8 (641-660)	641-648
9 (661-680)	661-668

I/O Slot	AO value register (1-8)
10 (681-700)	681-688
11 (701-720)	701-708
12 (721-740)	721-728
13 (741-760)	741-748
14 (761-780)	761-768

B.3.5 Setup Registers (2 byte signed registers, transmitted upper byte first)

Range: 1101-1420 (40 per board)

Example: To read the third AO last hold value register on board 4, find AO last hold value registers in the first row of the table, below, then move down that column until you reach the board 4 row to determine the range of AO last hold value register numbers, for that board, in this case (1237-1244). The third register in the range 1237 to 1244 would be 1239, so your Modbus command should request register 1239.

I/O Slot	AI scales register (1-32)	AO scales register (1-16)	AO last hold value register (17-24)
1 (1101-1140)	1101-1132	1101-1116	1117-1124
2 (1141-1180)	1141-1172	1141-1156	1157-1164
3 (1181-1220)	1181-1212	1181-1196	1197-1204
4 (1221-1260)	1221-1252	1221-1236	1237-1244
5 (1261-1300)	1261-1292	1261-1276	1277-1284
6 (1301-1340)	1301-1332	1301-1316	1317-1324
7 (1341-1380)	1341-1372	1341-1356	1357-1364
8 (1381-1420)	1381-1412	1381-1396	1397-1404
9 (1421-1460)	1421-1452	1421-1436	1437-1444
10 (1461-1500)	1461-1492	1461-1476	1477-1484
11 (1501-1540)	1501-1532	1501-1516	1517-1524
12 (1541-1580)	1541-1572	1541-1556	1557-1564
13 (1581-1620)	1581-1612	1581-1596	1597-1604
14 (1621-1660)	1621-1652	1621-1636	1637-1644

B.3.6 Long Input Registers (4 byte unsigned registers, transmitted upper word / upper byte first)

Range: 2101-2260 (20 per board)

Example: To read the HSC timestamp register on board 7, find HSC timestamp register in the first row of the table, below, then move down that column until you reach the board 7 row to determine the HSC timestamp register for that board, in this case (2233). So your Modbus command should request register 2233.

I/O Slot	HSC Counts Registers (1-12)	HSC Timestamp Register (13)
1 (2101-2120)	2101-2112	2113
2 (2121-2140)	2121-2132	2133
3 (2141-2160)	2141-2152	2153
4 (2161-2180)	2161-2172	2173
5 (2181-2200)	2181-2192	2193
6 (2201-2220)	2201-2212	2213
7 (2221-2240)	2221-2232	2233
8 (2241-2260)	2241-2252	2253
9 (2261-2280)	2261-2272	2273
10 (2281-2300)	2281-2292	2293
11 (2301-2320)	2301-2312	2313
12 (2321-2340)	2321-2332	2333
13 (2341-2360)	2341-2352	2353
14 (2361-2380)	2361-2372	2373

B.3.7 Floating Point (FP) Inputs (4 byte FP, transmitted upper word / upper byte first)

Range: 3101-3260 (20 per board)

Example: To read the eleventh FP input on board 7, go to the Board 7 column of the table, below, to determine the range of FP inputs for that board, in this case 3221-3240. The eleventh FP input in that range would be 3231, so your Modbus command should request FP input 3231.

I/O Slot	FP Inputs
1 (3101-3120)	3101-3120
2 (3121-3140)	3121-3140
3 (3141-3160)	3141-3160
4 (3161-3180)	3161-3180
5 (3181-3200)	3181-3200

I/O Slot	FP Inputs
6 (3201-3220)	3201-3220
7 (3221-3240)	3221-3240
8 (3241-3260)	3241-3260
9 (3261-3280)	3261-3280
10 (3281-3300)	3281-3300
11 (3301-3320)	3301-3320
12 (3321-3340)	3321-3340
13 (3341-3360)	3341-3360
14 (3361-3380)	3361-3380

B.3.8 Floating Point (FP) Outputs (4 byte FP, transmitted upper word / upper byte first)

Range: 4101-4260 (20 per board)

Example: To read the first FP output on board 2, go to the Board 2 column of the table, below, to determine the range of FP outputs for that board, in this case 4121-4140. The first FP output in that range would be 4121, so your Modbus command should request FP output 4121.

I/O Slot	FP Outputs
1 (4101-4120)	4101-4120
2 (4121-4140)	4121-4140
3 (4141-4160)	4141-4160
4 (4161-4180)	4161-4180
5 (4181-4200)	4181-4200
6 (4201-4220)	4201-4220
7 (4221-4240)	4221-4240
8 (4241-4260)	4241-4260
9 (4261-4280)	4261-4280
10 (4281-4300)	4281-4300
11 (4301-4320)	4301-4320
12 (4321-4340)	4321-4340
13 (4341-4360)	4341-4360
14 (4361-4380)	4361-4380

B.3.9 Floating Point (FP) Setup (4 byte FP, transmitted upper word / upper byte first)

Range: 5101-5420 (40 per board)

Example: To read the last FP setup register on board 3, go to the Board 3 column of the table, below, to determine the range of FP setup registers for that board, in this case 4121-4140. The last FP setup register in that range would be 4121, so your Modbus command should request FP setup register 4121.

I/O Slot	FP Setup Registers
1 (5101-5140)	5101-5140
2 (5141-5180)	5141-5180
3 (5181-5520)	5181-5520
4 (5221-5260)	5221-5260
5 (5261-5300)	5261-5300
6 (5301-5340)	5301-5340
7 (5341-5380)	5341-5380
8 (5381-5420)	5381-5420
9 (5421-5460)	5421-5460
10 (5461-5500)	5461-5500
11 (5501-5540)	5501-5540
12 (5541-5580)	5541-5580
13 (5581-5620)	5581-5620
14 (5621-5660)	5621-5660

B.3.10 Reversing the Order of Byte Transmission of a Register

Swapping the order in which bytes are transmitted will cause 2 bytes to be transmitted with the low order byte first, and 4 bytes to be transmitted upper word first, low order byte first.

To perform this swap, choose the proper register, from the tables above, then add 10000 to that register number when using it in a Modbus command.

B.3.11 Reversing the Order of Word Transmission of a Register

Swapping the order in which words are transmitted will cause 2 bytes to be transmitted as in 0 series, and will cause 4 bytes to be transmitted lower word first, high order byte first.

To perform this swap, choose the proper register, from the tables above, then add 20000 to that register number when using it in a Modbus command.

B.3.12 Reversing the Order of Byte / Word Transmission of a Register

Swapping the order in which bytes/words are transmitted will cause 2 bytes to be transmitted with the low order byte first, and 4 bytes to be transmitted lower word first, low byte first.

To perform this swap, choose the proper register, from the tables above, then add 30000 to that register number when using it in a Modbus command.

Appendix Z – Sources for Obtaining Material Safety Data Sheets

This device includes certain components or materials which may be hazardous if misused. For details on these hazards, please contact the manufacturer for the *most recent* material safety data sheet.

Manufacturer	General Description	Emerson Part Number & Media Notes
Eagle Picher http://www.eaglepicher.com	Lithium Thionyl Chloride Battery (1/2 AA, 3.6V, 950 mAh - On-board)	395600-01-4 Eagle Picher P/N LTC-9C
SAFT America http://www.saftbatteries.com	Lithium Thionyl Chloride Battery (1/2 AA, 3.6V, 950 mAh - On-board)	395600-01-4 SAFT P/N LS-14250

This page is intentionally left blank

Index

A

- Analog Input (AI) Module 3-20
 - Wiring 3-21
- Analog Output (AO) Module 3-25
 - Wiring 3-26
 - with readback 3-25, 3-28

B

- Backplanes 1-3
 - color code of connectors 2-5
- Battery
 - Disconnecting 5-12
 - enable switch 2-28
 - Lithium backup 5-12
 - replacing 5-12
- Bezel 2-35
 - Removing 5-5
 - Replacing 5-5
- Boot FLASH memory
 - amount 1-6
- Bulk power 2-17

C

- Cables
 - for Ethernet ports 2-34
 - RS-232 2-30
 - RS-485 2-32
 - shields 3-20
- Checking
 - LEDs 5-14
 - Wiring 5-22
- CJC Error
 - Thermocouple Module 3-44
- Class I, Division 2 2-2
 - special instruction for A-1
- color code of connectors 2-5
- Communication problems
 - common reasons for 5-13
- Communication Ports
 - defaults 4-1
 - Ethernet 2-34
 - Loop-back Test 5-29, 5-30, 5-31
 - RS-232 2-29
 - RS-485 2-32
- Core Updump See Updump
- CPU Module 1-5
 - description 1-5
 - Installation 2-25
 - Lithium battery backup 5-12
 - Removing 5-6

- Replacing 5-6
- switches 2-26

- Current
 - calculating maximum required 2-18

D

- Defaults
 - Comm Ports 4-1
- Diagnostic software 5-26
- Digital Input (DI) Module 3-8
 - Jumpers 3-9
 - Wiring 3-9
- Digital Output (DO) Module 3-13
 - Wiring 3-14
 - with readback 3-13, 3-18
- Disconnecting SRAM Battery 5-12

E

- Environmental specifications 2-2
- Error codes 5-22
- Ethernet ports 2-34
 - cables for 2-34
 - Loop-back Test 5-31

F

- Features 1-1
- Field repair 5-5
- Figures
 - 1-1. ControlWave IO Expansion Rack with 8 I/O modules 1-2
 - 1-2. ControlWave IO Exp Rack Housing Options 1-4
 - 1-3. I/O Modules 1-7
 - 2-1. ControlWave Process Automation Controller (PAC) with Two I/O Expansion Racks 2-4
 - 2-2. Color Coded Board Connectors 2-5
 - 2-3. PSSM Installed in ControlWaveEXP Slot #1 2-6
 - 2-4. PSSM & CPU (with SCB) Installed in Slot #1 and #2 (Respectively) 2-6
 - 2-5. 8 I/O module ControlWave I/O Rack - mounting diagram 2-8
 - 2-6. 4 I/O module ControlWave - mounting diagram 2-9
 - 2-7. 4 I/O module ControlWave - mounting diagram 2-10
 - 2-8. PSSM installed in slot 1 2-13
 - 2-9. Removing the Protective Case from the PSSM 2-15
 - 2-10. Jumper locations 2-16
 - 2-11. Wiring System Power to the PSSM 2-17

- 2-12. Wiring Field Power to the PSSM 2-18
- 2-13. Hot swapping a power supply 2-20
- 2-14. Watchdog field wiring 2-21
- 2-15. Redundancy Field Wiring 2-22
- 2-16. Location of TB2 on IO Switcher 2-23
- 2-17. ControlWave IO Expansion Rack CPU module without SCB 2-25
- 2-18. ControlWave IO Expansion Rack CPU module with SCB 2-26
- 2-19. CPU Module Communication Port Switches 2-27
- 2-20. Male DB9 9-Pin Connector 2-30
- 2-21. Full-duplex and Half-duplex Cable 2-31
- 2-22. RJ-45 Connector associated with COM3, ETH2, ETH3 (SCB) 2-32
- 2-23. RJ-45 Ethernet Connector 2-34
- 2-24. Standard 10/100Base-T Ethernet Cable (CPU Module to Hub) 2-34
- 2-25. Point-to-Point 10/100Base T Ethernet Cable 2-35
- 2-26 Bezel Assembly 2-36
- 3-1. Terminal housing assembly removal 3-2
- 3-2. ControlWave Chassis Slot Assignments 3-4
- 3-3. I/O Module (local termination) wire routing 3-5
- 3-4. I/O Module Remote Termination Wiring 3-7
- 3-5. DI Module – right side view – jumper locations 3-9
- 3-6. DI Module – Local Terminal block assembly assignments 3-10
- 3-7. Internally sourced DI Module – wiring diagram 3-10
- 3-8. Externally powered DI module wiring diagram 3-10
- 3-9. Remote DIN rail mountable terminal block assembly assignments 3-11
- 3-10. Remote DIN-rail mountable terminal block assembly assignments for relay isolated 120Vac DI operation 3-12
- 3-11. Local terminal block assembly assignments for open source isolated DO 3-14
- 3-12. Open source isolated DO module wiring diagram 3-15
- 3-13. Remote DIN-rail mountable terminal block assembly assignments for open source isolated DO 3-16
- 3-14. Remote DIN-rail mountable terminal block assembly assignments for relay isolated DO 3-17
- 3-15. Internally sourced 4-20mA current loop AI wiring diagram 3-21
- 3-16. Externally powered 4-20mA current loop AI – wiring diagram 3-21
- 3-17. Externally powered isolated 1-5V AI wiring diagram 3-22
- 3-18. Local AI module terminal block assembly 3-22
- 3-19. Remote DIN-rail mountable terminal block assembly assignments for 4-20mA AI 3-23
- 3-20. Remote DIN-rail mountable terminal block assembly assignments for 1-5V AI 3-24
- 3-21. Local AO module terminal block assembly assignments 3-26
- 3-22. Remote DIN-rail mountable terminal block assembly assignments for AO 3-27
- 3-23. 4-20mA current loop AO wiring diagram 3-28
- 3-24. UDI module – right side view – jumper locations 3-31
- 3-25. UDI (debounce enabled) wiring diagram 3-32
- 3-26. UDI debounce disabled wiring diagram 3-32
- 3-27. Local UDI terminal block configuration/diagram 3-33
- 3-28. Remote DIN-rail mountable terminal block assy. Assignments for UDI 3-34
- 3-29. Selecting Input Type in ControlWave Designer I/O Configurator 3-35
- 3-30. Isolated RTD module wiring diagram 3-37
- 3-31. Local isolated RTD module terminal block assy. assignments 3-38
- 3-32. Remote DIN-rail mountable terminal block assy. assignments 3-39
- 3-33. Isolated Thermocouple Module –wiring diagram 3-41
- 3-34. Local isolated Thermocouple module terminal block assy. assignments 3-42
- 3-35. Remote DIN-rail mountable terminal block assy. assignments 3-43
- 4-1. Power Switches on PSSM 4-1
- 5-1. HyperTerminal Mode Menu 5-3
- 5-2. HyperTerminal (Ready to Download) 5-4
- 5-3. Send File dialog box 5-4
- 5-4. HyperTerminal (Download in progress) 5-5
- 5-5 I/O Module to Be Replaced 5-8
- 5-6. Pulling the I/O Module Out of the Housing 5-8
- 5-7. I/O Loosening the Top Fastener 5-9
- 5-8. I/O Terminal Block Board and Terminal Housing Assembly Separated from the Rest of the Module 5-10
- 5-9. New I/O Module in Place Prior to Attaching Terminal Board and Terminal Housing Assembly 5-11
- 5-10. Lithium Backup Battery Removal Diagram 5-13
- 5-11. PSSM LED locations 5-17
- 5-12. CPU Module LED location Designations 5-17
- 5-13. Analog Input (AI) module LEDs 5-18
- 5-14. Analog output (AO) Module LEDs 5-18
- 5-15. Digital Input (DI) Module LEDs 5-19
- 5-16. Digital Output Module LEDs 5-19

5-17. Universal Digital Input (UDI) Module LEDs 5-20
 5-18. RTD Module LEDs 5-21
 5-19 . Thermocouple Module LEDs 5-22
 5-20. NetView 5-27
 5-21. WINDIAG Main Diagnostics Menu 5-28
 5-22. RS-232 Loop-back plug 5-29
 5-23. RS-485 Loop-back plug 5-29
 5-24. Communications Diagnostic menu 5-30
 5-25. RJ-45 Ethernet Loop-back plug 5-31
 5-26. Ethernet Diagnostic Menu 5-32
 Firmware upgrade 5-2
 HyperTerminal 5-2
 LocalView 5-2
 System Firmware Downloader 5-2
 FLASH memory
 amount 1-6
 Force recovery mode switch 2-28

G

Grounding 2-11, 3-6

H

Hazardous locations
 special instructions for A-1
 Hot swapping
 I/O module 5-7
 power supply on an PSSM 2-20
 Housing
 mounting 2-7
 Housings 1-3
 Humidity
 specifications 2-2
 HyperTerminal 5-2

I

I/O Modules 3-1
 AI 3-20
 AO 3-25
 DI 3-8
 DO 3-13
 general information about 1-6
 Installation (General) 3-1
 LLAI 3-40
 Placement in housings 3-3
 Removing 5-7
 Replacing 5-7
 RTD 3-36
 Thermocouple 3-40
 UDI 3-30
 Wiring 3-5
 Input Accuracy and Resolution
 Thermocouple Module 3-44
 Installation 2-1, 3-6
 Class 1, Div 2 2-2, A-1
 CPU 2-25
 I/O Modules 3-3

Overview 2-3
 PSSM 2-11

J

Jumpers
 DI 3-9
 PSSM 2-14
 RTD 3-36
 TC 3-40
 UDI 3-31

L

LEDs
 Checking 5-14
 Local termination 3-5
 LocalView 5-2
 Loop-back Test 5-29, 5-30
 Low Level Analog Input (LLAI) Module 3-40

M

Memory
 Boot FLASH 1-6
 FLASH
 amount 1-6
 SRAM
 amount 1-6
 MODBUS B-1
 Modules
 AI 3-20
 AO 3-25
 CPU 1-5, 2-25, 5-6
 DI 3-8
 DO 3-13
 I/O
 general information about 1-6
 LLAI 3-40
 PSSM 1-6, 2-11, 5-6
 RTD 3-36
 steady state current draw of 2-19
 Thermocouple 3-40
 UDI 3-30

O

Open MODBUS B-1

P

Packaging
 modules 2-4
 Port 80 display
 POST codes 5-23
 run time status codes 5-25
 Port Configuration switches
 for SCB 2-28
 Power Supply Sequencer (PSSM) Module
 description 1-6
 installation 2-11

- Removing 2-11, 5-6
- Replacing 5-6
- Wiring 2-17
- Power switch 4-1
- PSSM See Power Supply Sequencer (PSSM) Module

R

- Ranges
 - Thermocouple 3-44
- Redundancy
 - Enable/Disable switch 2-27
 - wiring 2-21
- Remote termination 3-6
- Repair in field 5-5
- Reset switch 5-26
- Resistance Temperature Device (RTD) Input Module 3-36
 - Wiring 3-37
- RS-232 ports 2-29
 - cables for 2-30
 - configuration switches 2-29
- RS-485 port 2-32
 - cables for 2-32
 - configuration switches 2-28
- RTD See Resistance Temperature Device (RTD) Input Module
- Running diagnostic software 5-26

S

- Secure gateway 1-7
- Service 5-1
- Shielding 3-6
- Site Considerations 2-1
- Soft Switches
 - Lock & unlock 2-26
- Specifications
 - for temperature, humidity, vibration 2-2
- SRAM Battery
 - Disconnecting 5-12
- SRAM control switch 2-27
- SRAM memory
 - amount 1-6
- Status codes 5-22
- Switches
 - CPU Board 2-26
 - power switch 4-1
 - Reset switch 5-26
- System Firmware Downloader 5-2

T

- Tables
 - 1-1. CPU Module Configurations 1-5
 - 2-1. PSSM Jumpers 2-14
 - 2-2. Steady State Current Draw for Bulk Power Supplies 2-19

- 2-3. Wiring a Digital Input to Indicate Power Supply Failure 2-23
- 2-4. PSSM Specifications 2-24
- 2-5. CPU Board Switch SW1 2-26
- 2-6. CPU Board Switch SW3 2-28
- 2-7. SCB Port Configuration Switches 2-28
- 2-8. SCB Port Configuration Switch SW2(for COM) 2-29
- 2-9. RS-232 Connectors on CPU 2-29
- 2-10. RS-232 Connectors on SCB 2-30
- 2-11. RS-232 Port Connector Pin Assignment 2-30
- 2-12. RS-485 Connectors on SCB 2-32
- 2-13. RS-485 COM3 Port Connector Pin Assignment 2-32
- 2-14. RS-485 Network Connections 2-33
- 2-15. Ethernet Ports 2-34
- 2-16. Ethernet 10/100Base-T CPU Module Pin Assignments 2-35
- 3-1. DI Module General Characteristics 3-8
- 3-2. DI Module Configurations 3-8
- 3-3. Jumper Assignments - DI Module 3-9
- 3-4. DO Module General Characteristics 3-13
- 3-5. Isolated DO Module General Characteristics 3-13
- 3-6. DO State on Power-up 3-13
- 3-7. AI Module General Characteristics 3-20
- 3-8. AI Module Configurations 3-21
- 3-9. AO Module General Characteristics 3-25
- 3-10. AO Module Configurations 3-26
- 3-11. UDI Module General Characteristics 3-30
- 3-12. UDI Module Configurations 3-31
- 3-13. Jumper Assignments – UDI Module 3-32
- 3-14. Isolated RTD Input Module General Characteristics 3-36
- 3-15. Isolated RTD Input Module Configurations 3-36
- 3-16. Jumper Assignments - Non-isolated HSC Module 3-37
- 3-17. Thermocouple Module General Characteristics 3-40
- 3-18. Isolated Thermocouple Module Configurations 3-40
- 3-19. Jumper Assignments - Isolated TC Module 3-40
- 3-20. Thermocouple Module Input Accuracy and Resolution 3-44
- 3-21. Thermocouple Module RTD Error with CJC at 25°C 3-44
- 4-1. Default Comm Port Settings (by PCB) 4-1
- 5-1. LED Assignments on Modules 5-14
- 5-2. I/O Field Wiring – Terminal Block Reference 5-22
- 5-3. Port 80 POST status codes 5-23
- 5-4. Port 80 Run Time Status Codes 5-25
- Temperature specifications 2-2
- termination

- local 3-5
- remote 3-6
- Thermocouple Module 3-40
 - CJC Error 3-44
 - Input Accuracy and Resolution 3-44
 - ranges 3-44
 - wiring 3-41
- Troubleshooting 5-1, 5-13
 - common communication configuration problems 5-13

U

- Universal Digital Input (UDI) Module 3-30
 - Wiring 3-32
- Unpacking components 2-4
- Updump
 - procedure 5-32
 - switch 2-27
- Upgrading firmware 5-2

V

- Vibration

- specifications 2-2

W

- Watchdog
 - and PSSM 2-21
 - CPU switch 2-26
- WINDIAG 5-26
- Wiring
 - AI 3-21
 - AO 3-26
 - Checking 5-22
 - DI 3-9
 - DO 3-14
 - for redundancy 2-21
 - I/O Modules 3-5
 - PSSM 2-17
 - RTD 3-37
 - Thermocouple 3-41
 - UDI 3-32
 - watchdog circuit 2-21

Headquarters:

Emerson Process Management
Remote Automation Solutions
6005 Rogerdale Road
Houston, TX 77072 U.S.A.
T +1 281 879 2699 | F +1 281 988 4445
www.EmersonProcess.com/Remote

Europe:

Emerson Process Management
Remote Automation Solutions
Unit 8, Waterfront Business Park
Dudley Road, Brierley Hill
Dudley UK DY5 1LX
T +44 1384 487200 | F +44 1384 487258
www.EmersonProcess.com/Remote

North American/Latin America:

Emerson Process Management
Remote Automation Solutions
6005 Rogerdale Road
Houston TX USA 77072
T +1 281 879 2699 | F +1 281 988 4445
www.EmersonProcess.com/Remote

Middle East/Africa:

Emerson Process Management
Remote Automation Solutions
Emerson FZE
P.O. Box 17033
Jebel Ali Free Zone – South 2
Dubai U.A.E.
T +971 4 8118100 | F +971 4 8865465
www.EmersonProcess.com/Remote

Asia-Pacific:

Emerson Process Management
Remote Automation Solutions
1 Pandan Crescent
Singapore 128461
T +65 6777 8211 | F +65 6777 0947
www.EmersonProcess.com/Remote

© 2015 Remote Automation Solutions, a business unit of Emerson Process Management. All rights reserved.

Remote Automation Solutions, a business unit of Emerson Process Management, shall not be liable for technical or editorial errors in this manual or omissions from this manual. REMOTE AUTOMATION SOLUTIONS MAKES NO WARRANTIES, EXPRESSED OR IMPLIED, INCLUDING THE IMPLIED WARRANTIES OF MERCHANTABILITY AND FITNESS FOR A PARTICULAR PURPOSE WITH RESPECT TO THIS MANUAL AND, IN NO EVENT SHALL REMOTE AUTOMATION SOLUTIONS BE LIABLE FOR ANY INCIDENTAL, PUNITIVE, SPECIAL OR CONSEQUENTIAL DAMAGES INCLUDING, BUT NOT LIMITED TO, LOSS OF PRODUCTION, LOSS OF PROFITS, LOSS OF REVENUE OR USE AND COSTS INCURRED INCLUDING WITHOUT LIMITATION FOR CAPITAL, FUEL AND POWER, AND CLAIMS OF THIRD PARTIES.

Emerson Process Management Ltd, Remote Automation Solutions (UK), is a wholly owned subsidiary of Emerson Electric Co. doing business as Remote Automation Solutions, a business unit of Emerson Process Management. FloBoss, ROCLINK, ControlWave, Helicoid, and OpenEnterprise are trademarks of Remote Automation Solutions. AMS, PlantWeb, and the PlantWeb logo are marks owned by one of the companies in the Emerson Process Management business unit of Emerson Electric Co. Emerson Process Management, Emerson and the Emerson logo are trademarks and service marks of the Emerson Electric Co. All other marks are property of their respective owners.

The contents of this publication are presented for informational purposes only. While every effort has been made to ensure informational accuracy, they are not to be construed as warranties or guarantees, express or implied, regarding the products or services described herein or their use or applicability. Remote Automation Solutions reserves the right to modify or improve the designs or specifications of such products at any time without notice. All sales are governed by Remote Automation Solutions' terms and conditions which are available upon request. Remote Automation Solutions does not assume responsibility for the selection, use or maintenance of any product. Responsibility for proper selection, use and maintenance of any Remote Automation Solutions product remains solely with the purchaser and end-user.