

# Instruction Manual CI-ControlWave IES

Issue: 07/2001

## ControlWave™

### Industrial Ethernet Real-time Switches

- 5 Port Switch: BB-GT-5ES-1
- 4+1 Fiber Single-mode Switch (SM): BB-GT-5ES-2CS
- 4+1 Fiber Multi-mode Switch (MM): BB-GT-5ES-3SC

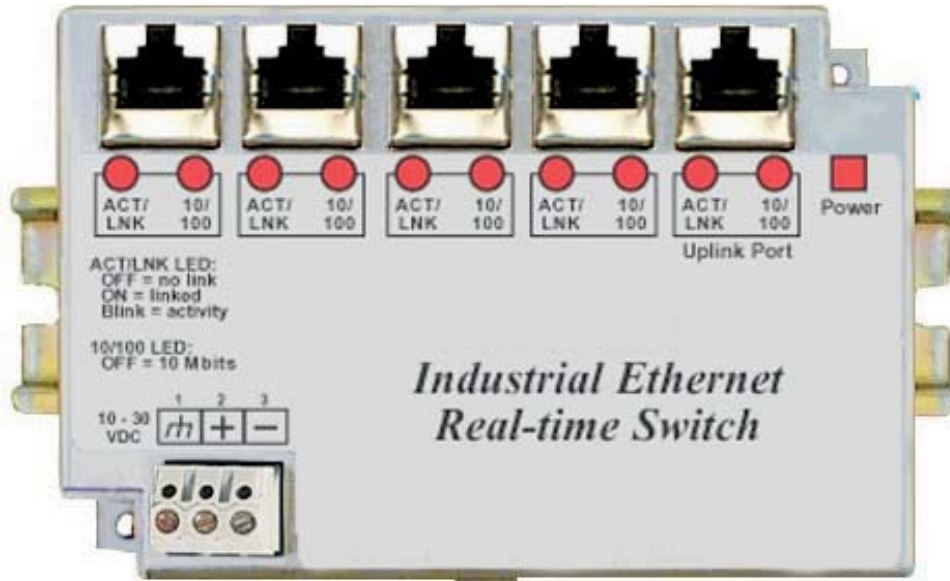

ControlWave

**Bristol Babcock**

**NOTICE**  
*Copyright Notice*

The information in this document is subject to change without notice. Every effort has been made to supply complete and accurate information. However, Bristol Babcock assumes no responsibility for any errors that may appear in this document.

**Request for Additional Instructions**

Additional copies of instruction manuals may be ordered from the address below per attention of the Sales Order Processing Department. List the instruction book numbers or give complete model number, serial or software version number. Furnish a return address that includes the name of the person who will receive the material. Billing for extra copies will be according to current pricing schedules.

**ControlWave™** is a trademark of Bristol Babcock. Other trademarks or copy-righted products mentioned in this document are for information only, and belong to their respective companies, or trademark holders.

Copyright (c) 2001 Bristol Babcock, 1100 Buckingham St., Watertown, CT 06795. No part of this manual may be reproduced in any form without the express written permission of Bristol Babcock.

## **IMPORTANT! READ INSTRUCTIONS BEFORE STARTING!**

Be sure that these instructions are carefully read and understood before any operation is attempted. Improper use of this device in some applications may result in damage or injury. The user is urged to keep this book filed in a convenient location for future reference.

These instructions may not cover all details or variations in equipment or cover every possible situation to be met in connection with installation, operation or maintenance. Should problems arise that are not covered sufficiently in the text, the purchaser is advised to contact Bristol Babcock for further information.

### **EQUIPMENT APPLICATION WARNING**

The customer should note that a failure of this instrument or system, for whatever reason, may leave an operating process without protection. Depending upon the application, this could result in possible damage to property or injury to persons. It is suggested that the purchaser review the need for additional backup equipment or provide alternate means of protection such as alarm devices, output limiting, fail-safe valves, relief valves, emergency shutoffs, emergency switches, etc. If additional information is required, the purchaser is advised to contact Bristol Babcock.

### **RETURNED EQUIPMENT WARNING**

When returning any equipment to Bristol Babcock for repairs or evaluation, please note the following: The party sending such materials is responsible to ensure that the materials returned to Bristol Babcock are clean to safe levels, as such levels are defined and/or determined by applicable federal, state and/or local law regulations or codes. Such party agrees to indemnify Bristol Babcock and save Bristol Babcock harmless from any liability or damage which Bristol Babcock may incur or suffer due to such party's failure to so act.

### **ELECTRICAL GROUNDING**

Metal enclosures and exposed metal parts of electrical instruments must be grounded in accordance with OSHA rules and regulations pertaining to "Design Safety Standards for Electrical Systems," 29 CFR, Part 1910, Subpart S, dated: April 16, 1981 (OSHA rulings are in agreement with the National Electrical Code).

The grounding requirement is also applicable to mechanical or pneumatic instruments that include electrically-operated devices such as lights, switches, relays, alarms, or chart drives.

## WARRANTY

- A. Bristol warrants that goods described herein and manufactured by Bristol are free from defects in material and workmanship for one year from the date of shipment unless otherwise agreed to by Bristol in writing.
- B. Bristol warrants that goods repaired by it pursuant to the warranty are free from defects in material and workmanship for a period to the end of the original warranty or ninety (90) days from the date of delivery of repaired goods, whichever is longer.
- C. Warranties on goods sold by, but not manufactured by Bristol are expressly limited to the terms of the warranties given by the manufacturer of such goods.
- D. All warranties are terminated in the event that the goods or systems or any part thereof are (i) misused, abused or otherwise damaged, (ii) repaired, altered or modified without Bristol's consent, (iii) not installed, maintained and operated in strict compliance with instructions furnished by Bristol, or (iv) worn, injured or damaged from abnormal or abusive use in service time.
- E. THESE WARRANTIES ARE EXPRESSLY IN LIEU OF ALL OTHER WARRANTIES EXPRESS OR IMPLIED (INCLUDING WITHOUT LIMITATION WARRANTIES AS TO MERCHANTABILITY AND FITNESS FOR A PARTICULAR PURPOSE), AND NO WARRANTIES, EXPRESS OR IMPLIED, NOR ANY REPRESENTATIONS, PROMISES, OR STATEMENTS HAVE BEEN MADE BY BRISTOL UNLESS ENDORSED HEREIN IN WRITING. FURTHER, THERE ARE NO WARRANTIES WHICH EXTEND BEYOND THE DESCRIPTION OF THE FACE HEREOF.
- F. No agent of Bristol is authorized to assume any liability for it or to make any written or oral warranties beyond those set forth herein.

## REMEDIES

- A. Buyer's sole remedy for breach of any warranty is limited exclusively to repair or replacement without cost to Buyer of any goods or parts found by Seller to be defective if Buyer notifies Bristol in writing of the alleged defect within ten (10) days of discovery of the alleged defect and within the warranty period stated above, and if the Buyer returns such goods to Bristol's Watertown office, unless Bristol's Watertown office designates a different location, transportation prepaid, within thirty (30) days of the sending of such notification and which upon examination by Bristol proves to be defective in material and workmanship. Bristol is not responsible for any costs of removal, dismantling or reinstallation of allegedly defective or defective goods. If a Buyer does not wish to ship the product back to Bristol, the Buyer can arrange to have a Bristol service person come to the site. The Service person's transportation time and expenses will be for the account of the Buyer. However, labor for warranty work during normal working hours is not chargeable.
- B. Under no circumstances will Bristol be liable for incidental or consequential damages resulting from breach of any agreement relating to items included in this quotation from use of the information herein or from the purchase or use by Buyer, its employees or other parties of goods sold under said agreement.

## How to return material for Repair or Exchange

Before a product can be returned to Bristol Babcock for repair, upgrade, exchange, or to verify proper operation, form (GBU 13.01) must be completed in order to obtain a RA (Return Authorization) number and thus ensure an optimal lead time. Completing the form is very important since the information permits the Bristol Babcock Repair Dept. to effectively and efficiently process the repair order.

You can easily obtain a RA number by:

### A. FAX

Completing the form (GBU 13.01) and faxing it to (860) 945-3875. A BBI Repair Dept. representative will return call (or other requested method) with a RA number.

### B. E-MAIL

Accessing the form (GBU 13.01) via the Bristol Babcock Web site ([www.bristolbabcock.com](http://www.bristolbabcock.com)) and sending it via E-Mail to [brepair@bristolbabcock.com](mailto:brepair@bristolbabcock.com). A BBI Repair Dept. representative will return E-Mail (or other requested method) with a RA number.

### C. Mail

Mail the form (GBU 13.01) to

**Bristol Babcock Inc.**  
Repair Dept.  
1100 Buckingham Street  
Watertown, CT 06795

A BBI Repair Dept. representative will return call (or other requested method) with a RA number.

### D. Phone

Calling the BBI Repair Department at (860) 945-2442. A BBI Repair Department representative will record a RA number on the form and complete Part I, then send the form to the Customer via fax (or other requested method) for Customer completion of Parts II & III.

A copy of the completed Repair Authorization Form with issued RA number should be included with the product being returned. This will allow us to quickly track, repair, and return your product to you.

# Bristol Babcock Inc. Repair Authorization Form

(Providing this information will permit BBI to effectively and efficiently process your return. Completion is required to receive optimal lead time. Lack of information may result in increased lead times.)

Date \_\_\_\_\_ RA # \_\_\_\_\_ SH \_\_\_\_\_ Line No. \_\_\_\_\_

**Standard Repair Practice is as follows:** Variations to this is practice may be requested in the "Special Requests" section.

- Evaluate / Test / Verify Discrepancy
- Repair / Replace / etc. in accordance with this form
- Return to Customer

**Please be aware of the Non warranty standard charge:**

- There is a \$100 minimum evaluation charge, which is applied to the repair if applicable (✓ in "returned" B,C, or D of part III below)

## Part I Please complete the following information for single unit or multiple unit returns

Address No. \_\_\_\_\_ (office use only) Address No. \_\_\_\_\_ (office use only)

Bill to : \_\_\_\_\_ Ship to: \_\_\_\_\_

\_\_\_\_\_  
\_\_\_\_\_

Purchase Order: \_\_\_\_\_ Contact Name: \_\_\_\_\_

Phone: \_\_\_\_\_ Fax: \_\_\_\_\_ E-Mail: \_\_\_\_\_

## Part II Please complete Parts II & III for each unit returned

Model No./Part No. \_\_\_\_\_ Description \_\_\_\_\_

Range/Calibration \_\_\_\_\_ S/N \_\_\_\_\_

**Reason for return** :  Failure  Upgrade  Verify Operation  Other \_\_\_\_\_

1. Describe the conditions of the failure (Frequency/Intermittent, Physical Damage, Environmental Conditions, Communication, CPU watchdog, etc.)

\_\_\_\_\_  
\_\_\_\_\_  
\_\_\_\_\_

(Attach a separate sheet if necessary)

2. Comm. interface used:  Standalone  RS-485  Ethernet  Modem (PLM (2W or 4W) or SNW)  Other: \_\_\_\_\_

3. What is the **Firmware** revision? \_\_\_\_\_ What is the **Software** & version? \_\_\_\_\_

## Part III If checking "replaced" for any question below, check an alternate option if replacement is not available

A. If product is within the warranty time period but is excluded due to BBI's warranty clause, would you like the product:  repaired  returned  replaced  scrapped?

B. If product were found to exceed the warranty period, would you like the product:  repaired  returned  replaced  scrapped?

C. If product is deemed not repairable would you like your product:  returned  replaced  scrapped?

D. If BBI is unable to verify the discrepancy, would you like the product:  returned  replaced  \*see below?

\* Continue investigating by contacting the customer to learn more about the problem experienced? The person to contact that has the most knowledge of the problem is: \_\_\_\_\_ phone \_\_\_\_\_

If we are unable to contact this person the backup person is: \_\_\_\_\_ phone \_\_\_\_\_

**Special Requests:** \_\_\_\_\_

\_\_\_\_\_

Ship prepaid to: Bristol Babcock Inc., Repair Dept., 1100 Buckingham Street, Watertown, CT 06795  
Phone: 860-945-2442 Fax: 860-945-3875

# Bristol Babcock *Training*

## GET THE MOST FROM YOUR BRISTOL BABCOCK INSTRUMENT OR SYSTEM



- Avoid Delays and problems in getting your system on-line
- Minimize installation, start-up and maintenance costs.
- Make the most effective use of our hardware and software.
- Know your system.

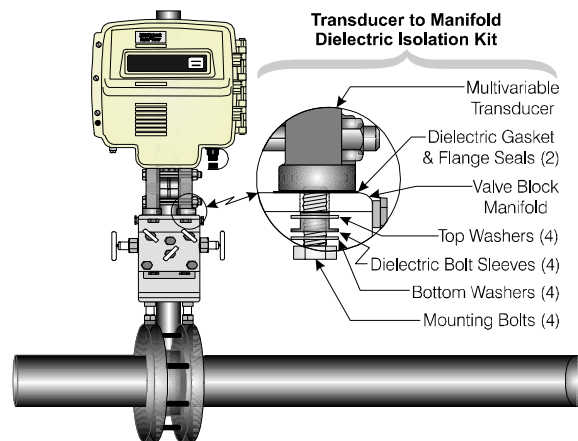

As you know, a well-trained staff is essential to your operation. Bristol Babcock offers a full schedule of classes conducted by full-time, professional instructors. Classes are offered throughout the year at four locations: Houston, Birmingham, Orlando and our Watertown, CT headquarters. By participating in our training, your personnel can learn how to install, calibrate, configure, program and maintain any and all Bristol Babcock products and realize the full potential of your system.

For information or to enroll in any class, contact our training department in Watertown at (860) 945-2269. For Houston classes, you can also contact our Houston office, at (713) 685-6200.



## A Few Words About Bristol Babcock

For over 100 years, Bristol<sup>®</sup> has been providing innovative solutions for the measurement and control industry. Our product lines range from simple analog chart recorders, to sophisticated digital remote process controllers and flow computers, all the way to turnkey SCADA systems. Over the years, we have become a leading supplier to the electronic gas measurement, water purification, and wastewater treatment industries.

On off-shore oil platforms, on natural gas pipelines, and maybe even at your local water company, there are Bristol Babcock instruments, controllers, and systems running year-in and year-out to provide accurate and timely data to our customers.

## Getting Additional Information

In addition to the information contained in this manual, you may receive additional assistance in using this product from the following sources:

### Contacting Bristol Babcock Directly

Bristol Babcock's world headquarters are located at 1100 Buckingham Street, Watertown, Connecticut 06795, U.S.A.

Our main phone numbers are:

**(860) 945-2200**  
**(860) 945-2213 (FAX)**

Regular office hours are Monday through Friday, 8:00AM to 4:30PM Eastern Time, excluding holidays and scheduled factory shutdowns. During other hours, callers may leave messages using Bristol's voice mail system.

### Telephone Support - Technical Questions

During regular business hours, Bristol Babcock's Application Support Group can provide telephone support for your technical questions.

For technical questions about TeleFlow<sup>™</sup> products call (860) 945-8604.

For technical questions about **ControlWave** call (860) 945-2244 or (860) 945-2286.

For technical questions regarding Bristol's **OpenEnterprise** product, call (860) 945-2501 or e-mail: **openenterprise@bristolbabcock.com**

For technical questions regarding **ACCOL** products, **Open BSI Utilities**, as well as Bristol's **Enterprise Server<sup>®</sup>/Enterprise Workstation<sup>®</sup>** products, call (860) 945-2286.

For technical questions about **Network 3000** hardware, call (860) 945-2502.

You can e-mail the Application Support Group at: **bsupport@bristolbabcock.com**

The Application Support Group also maintains a service area within our main web site. Technical information, as well as software updates are available in this area. To access our web site, go to: [bristolbabcock.com/services/techsupport/](http://bristolbabcock.com/services/techsupport/)

For assistance in interfacing Bristol Babcock hardware to radios, contact Communication Technologies in Orlando, FL at (407) 629-9463 or (407) 629-9464.

### **Telephone Support - Non-Technical Questions, Product Orders, etc.**

Questions of a non-technical nature (product orders, literature requests, price and delivery information, etc.) should be directed to the nearest sales office (listed below) or to your Bristol-authorized sales representative.

#### **Major U.S. Sales Offices**

Watertown, CT (860) 945-2262  
Birmingham, AL (205) 980-2010  
Ontario, CA (909) 923-8488  
Farmington, NM (505) 327-3271  
Houston, TX (713) 685-6200  
Richardson, TX (972) 238-8935

#### **Major International Sales Offices:**

Bristol Babcock Ltd (UK): (441) 562-820-001  
Bristol of Canada: (416) 675-3820  
Bristol Babcock Asia Pacific 61 8-9455-9955  
BBI, S.A. de C.V. (Mexico) (525) 254-2131

Please call the main Bristol Babcock number (860-945-2200) if you are unsure which office covers your particular area.

### **Visit our Site on the World Wide Web**

For general information about Bristol Babcock and its products, please visit our site on the World Wide Web at: **[www.bristolbabcock.com](http://www.bristolbabcock.com)**

## Industrial Ethernet Real-time Switches



### Contents at a Glance:

<b>Section 1</b>	<b>General Information</b>	<b>Page 3</b>
<b>Section 2</b>	<b>LED Indicators</b>	<b>Page 4</b>
<b>Section 3</b>	<b>Installation</b>	<b>Page 5</b>
<b>Section 4</b>	<b>Power Wiring</b>	<b>Page 6</b>
<b>Section 5</b>	<b>Ethernet Wiring</b>	<b>Page 7</b>
<b>Section 6</b>	<b>Switching Features</b>	<b>Page 9</b>
<b>Section 7</b>	<b>Technical Specifications</b>	<b>Page 11</b>
<b>Section 8</b>	<b>Service Information</b>	<b>Page 13</b>



This manual applies to the following products:

**5 port switch, 4+1 fiber single-mode switch (SM), 4+1 fiber multi-mode switch (MM)**

**INSTALLATION AND HAZARDOUS AREA WARNINGS:**

These products should not be used to replace proper safety interlocking. No software-based device (or any other solid-state device) should ever be designed to be responsible for the maintenance of consequential equipment or personnel safety. In particular, no responsibility for damages, either direct or consequential, that result from the use of this equipment in any application will be taken by the distributor of this product.

All power, input and output (I/O) wiring must be in accordance with Class I, Division 2 wiring methods and in accordance with the authority having jurisdiction.

- WARNING (EXPLOSION HAZARD) -**      SUBSTITUTION OF COMPONENTS MAY IMPAIR SUITABILITY FOR CLASS 1, DIVISION 2.
  
- WARNING (EXPLOSION HAZARD) -**      WHEN IN HAZARDOUS LOCATIONS, DISCONNECT POWER BEFORE REPLACING OR WIRING UNITS.
  
- WARNING (EXPLOSION HAZARD) -**      DO NOT DISCONNECT EQUIPMENT UNLESS POWER HAS BEEN SWITCHED OFF OR THE AREA IS KNOWN TO BE NONHAZARDOUS.

**FCC Statement:**

This equipment has been tested and found to comply with the limits for a Class B digital device, pursuant to Part 15 of the FCC Rules. These limits are designed to provide reasonable protection against harmful interference in a residential installation. This equipment generates, uses and can radiate radio frequency energy and, if not installed and used in accordance with the instructions, may cause harmful interference to radio communications. However, there is no guarantee that interference will not occur in a particular installation. If this equipment does cause harmful interference to radio or television reception, which can be determined by turning the equipment off and on, the user is encouraged to try to correct the interference by one or more of the following measures: Reorient or relocate the receiving antenna; Increase the separation between the equipment and receiver; Connect the equipment into an outlet on a circuit different from that to which the receiver is connected; Consult the dealer or an experienced radio/TV technician for help.

**Copyright & Trademarks:**

Copyright © 2001, All Rights Reserved.

<b>Note:</b> All information in this document is subject to change without notice.
------------------------------------------------------------------------------------

# Section 1

## Overview

# General Information

This manual will help you install and maintain the Industrial Ethernet Switches. These unmanaged switches are extremely easy to install and operate because little or no user configuration is required. Once the Ethernet connections are made and the unit is powered up it will immediately begin to operate.

## Operation

Unlike an Ethernet hub that broadcasts all messages out all ports, the Industrial Ethernet Switches will intelligently route Ethernet messages only out the appropriate port. The major benefits of this are increased bandwidth and speed, reduction or elimination of message collisions, and deterministic performance when tied with real-time systems.

The Industrial Ethernet Switches support both 10BaseT (10 Mbps) and 100BaseTx (100 Mbps) on their RJ45 ports. Each of these ports will independently auto-sense the speed, allowing you to interface to regular or fast Ethernet devices. Some models also have a 100BaseFX (100 Mbps) fiber optic port.

Refer to Section 6 for more information on Industrial Ethernet Switch operation and features.

## Performance Specifications

These general specifications apply to the Industrial Ethernet Switches. Refer to Section 7 for complete technical specifications.

Ports (models vary)	10/100BaseT(x) (Shielded RJ45), 100BaseFX (SC connectors)
Required Voltage	10 - 30 VDC (see Section 7 for current draw for each model)
Ethernet Standards	IEEE 802.3 (10BaseT), 802.3u (100BaseTX), 802.3x (Full Duplex)
Ethernet Protocols	All standard IEEE 802.3 protocols supported
Speed Per Port	RJ45: 10 or 100 Mbps (half duplex), 20 or 200 Mbps (full duplex) Fiber: 100 Mbps (half duplex), 200 Mbps (full duplex)
Ethernet Isolation	1200 Volts RMS (for 1 minute)
Operating Temp.	-40 to 85 °C
Humidity	5 to 95% (non-condensing)
Screw Terminals	5 port switch: 14 AWG max. (tighten to 3.48 in-lbs. max.) 5 port fiber switch: 12 AWG max. (tighten to 5.3 in-lbs. max.)

## Standards and Safety

The Industrial Ethernet Switch meets the following standards:

- Electrical safety** - UL 508, CSA C22/14; EN61010-1 (IEC1010)
- EMI emissions** - FCC part 15, ICES 003, EN55022; Class B
- EMC immunity** – EN61326-1(EN61000-4--2, 3, 4, and 6)

**Hazardous locations** – UL 1604, CSA C22.2/213 (Class 1, Div. 2), Groups A, B, C, D; Cenelec EN50021 (Zone 2)

**Install the Industrial Ethernet Switch in accordance with local and national electrical codes.**

**Lightning Danger: Do not work on equipment during periods of lightning activity.**

**Do not connect a telephone line into one of the Ethernet RJ45 connectors.**



## Section 2

## LED Indicators

### Overview

The Industrial Ethernet Switches have communication LEDs for each port and a power LED. Refer to the pictures below for the typical location of these LEDs. The exact location of these LEDs may vary between the different models.

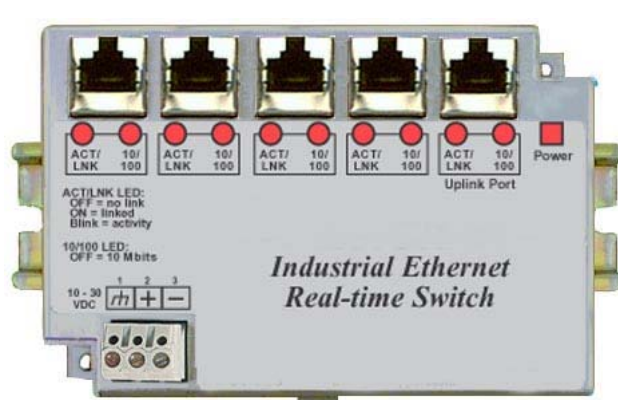

FIVE PORT SWITCH

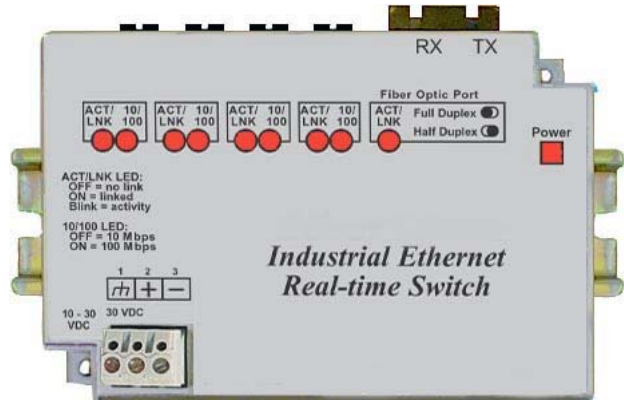

FIVE PORT WITH FIBER SWITCH

### Power LED

This LED will be on solid when proper power has been applied to the unit.

### ACT / LNK LEDs

The activity (ACT) and link (LNK) indication is combined into one LED on the Industrial Ethernet Switches. There is one of these LEDs per port.

**OFF** – This would indicate that there is not a proper Ethernet connection (Link) between the port and another Ethernet device. Make sure the proper cable type is in use and that it has been plugged securely into the ports at both ends. See section 5 for proper Ethernet cabling.

**ON Solid (not flashing)** – This would indicate that there is a proper Ethernet connection (Link) between the port and another Ethernet device, but no communications activity is detected.

**Flashing** - This would indicate that there is a proper Ethernet connection (Link) between the port and another Ethernet device, and that there is communications activity.

### 10 / 100 LEDs

This LED indicates what speed of communications is detected on the port. There is one of these LEDs per RJ45 port. (The fiber optic port does not have one of these LEDs because its speed is fixed at 100 Mbps.)

**OFF** – A 10 Mbps (10BaseT) connection is detected.

**ON** – A 100 Mbps (100BaseTx) connection is detected.

(Mbps = Megabits per Second)

## Section 3

## Installation

### Overview

The Industrial Ethernet Switch can be snapped onto a standard DIN rail (EN50022) or screwed directly to a flat panel. Refer to the mechanical drawings below.

**Note:** The Ethernet connections for the 5 port switch come out the face of the unit. However, the Ethernet connections for the 5 port fiber switch come out the top. Make sure to allow enough room to route your Ethernet cables.

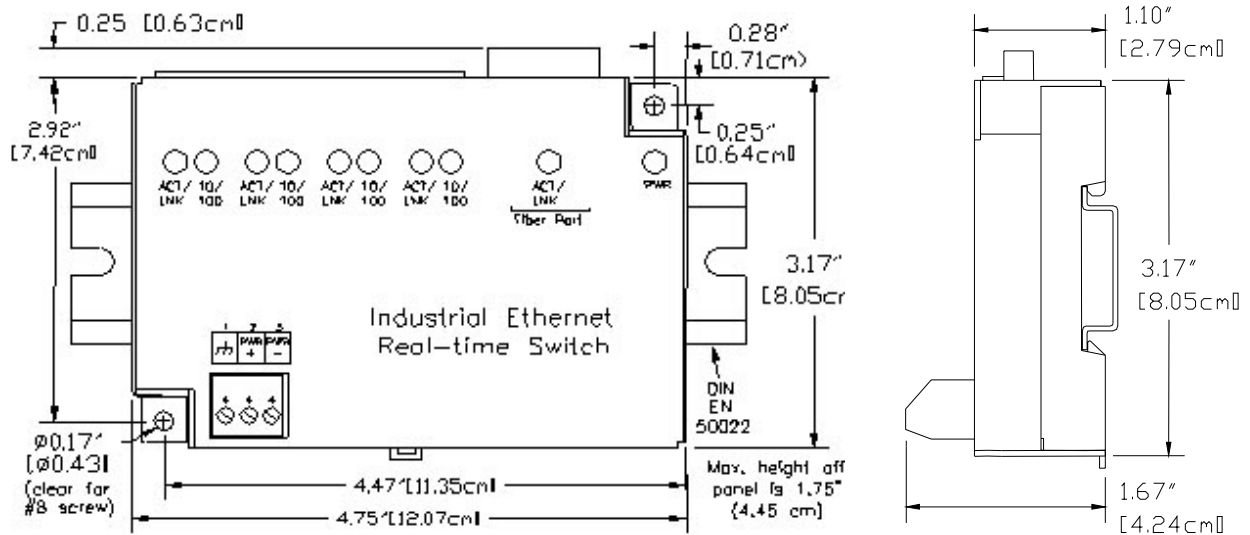
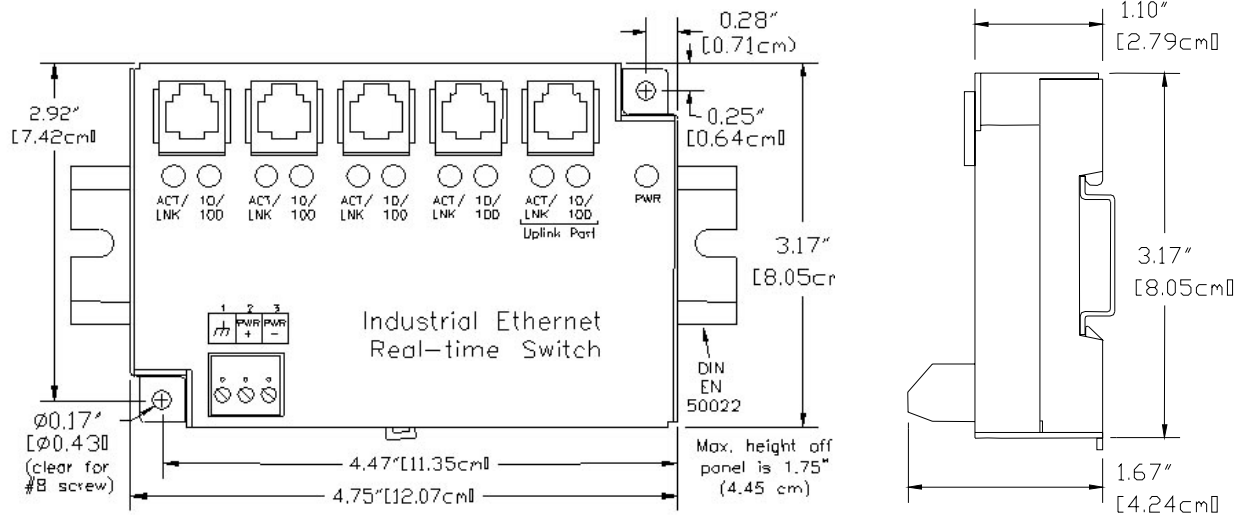

## Section 4

## Power Wiring

### Overview

Industrial Ethernet Switches can be powered from the same DC source that is used to power your I/O devices. 10 to 30 VDC needs to be applied to terminals 2 and 3. Refer to the wiring diagram below.

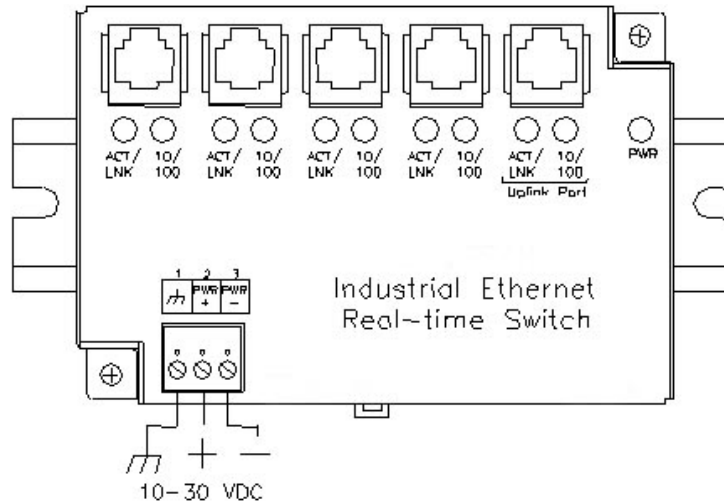

### Screw Torque

The screw terminals should be tightened as follows:

For the 5 port switch, tighten screw terminals to a maximum 3.48 in-lbs (0.4 Nm).

For the 5 port fiber switch, tighten screw terminals to a maximum 5.3 in-lbs (0.6 Nm).

## Section 5

### Overview

## Ethernet Wiring

The Industrial Ethernet Switch provides connections to Ethernet devices on the factory floor. Typically the uplink port or fiber port is used to connect to another Ethernet switch or hub that is connected to the main Ethernet backbone. The other four Ethernet ports are then connected to Ethernet devices such as PLCs, Ethernet I/O, or industrial computers. Electrical isolation is provided on the Ethernet ports for increased reliability. **Please follow normal 10/100BaseT(x) and 100BaseFX Ethernet wiring practices when installing the Industrial Ethernet Switch.**

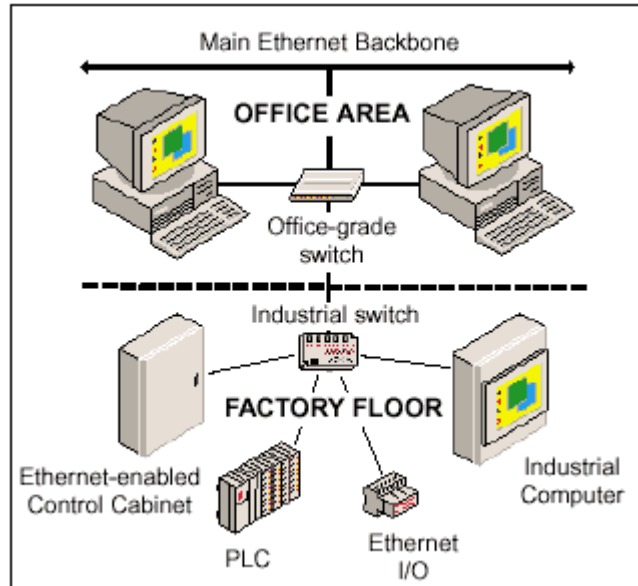

**Typical Industrial Ethernet Switch Installation**

### Ethernet RJ45 Wiring Guidelines

#### Ethernet RJ45 Cable Type

Use data-quality (not voice-quality) twisted pair cable rated category 5 with standard RJ45 connectors. For best performance use shielded cable. Please note that these cables are available as straight-thru or cross-over configurations. The following is a guide for when to use each type:

Ethernet Switch STANDARD Port to	Cable Type to Use	Ethernet Switch UPLINK Port to	Cable Type to Use
PC card	Straight-thru	PC card	Cross-over
Ethernet I/O	Straight-thru	Ethernet I/O	Cross-over
PLC	Straight-thru	PLC	Cross-over
Other Ethernet enabled devices	Straight-thru	Other Ethernet enabled devices	Cross-over
* Uplink port on another switch or hub	* Straight-thru (see note)	Standard port on another switch or hub	Straight-thru

**\* Note:** Some Ethernet switches and hubs have a settable switch on their Uplink port that will change how the port is internally wired. Make sure this switch is set in the “To Hub/Switch (MDI)” position as opposed to the “To PC (MDI-X)” position.

Straight-thru Cable Wiring		Cross-over Cable Wiring	
Pin 1	Pin 1	Pin 1	Pin 3
Pin 2	Pin 2	Pin 2	Pin 6
Pin 3	Pin 3	Pin 3	Pin 1
Pin 6	Pin 6	Pin 6	Pin 2

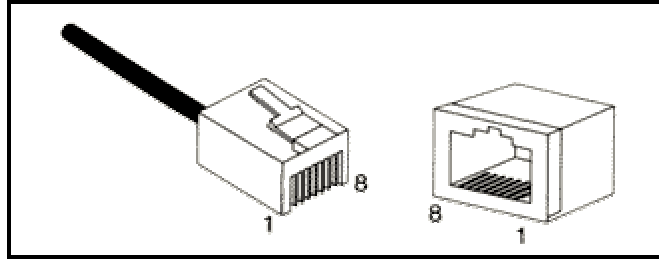

**Ethernet Connector  
Pin Positions**

Pin #	Assignment
1	TX+
2	TX-
3	RX+
6	RX-

**Ethernet Connector  
Pin Assignments**

**Cable Distance**

The maximum cable length for 10/100BaseT(x) is typically 100 meters (328 ft.). Refer to the following chart for some general guidelines.

From	To	Maximum Distance
Switch	Switch or Hub	100 meters (328 feet)
10Mbps Hub	10Mbps Hub	100 meters (328 feet)
100Mbps Hub	100Mbps Hub	5 meters (16 feet)
Switch or Hub	PLC, Ethernet I/O, PC, etc.	100 meters (328 feet)

**Note:** Hubs and Switches are different devices. Hubs simply broadcast all messages out all ports. Switches intelligently route messages only out the appropriate port. All the devices described in this manual are Switches.

**Ethernet  
Fiber Wiring  
Guidelines**

The 5 port fiber MM has one pair of FX multimode SC connectors that support a maximum segment length of 2 km. The 5 port fiber SM has one pair of FX singlemode SC connectors that support a maximum segment length of 15 km.

The fiber optic port on the switch is comprised of a pair of SC connectors which are labeled with “RX” and “TX”. When making your fiber optic connections, make sure that the transmit (TX) port of the switch connects to the receive (RX) port of the other device, and the receive (RX) port of the switch connects to the transmit (TX) port of the other device.

The ACT/LNK LED will be ON solid when you have made a proper connection.

**Full or Half  
Duplex  
Operation**

The RJ45 ports will auto-sense for Full or Half duplex operation. No user configuration is necessary. The fiber optic port has a movable slide-switch that allows you to select either Full or Half duplex operation. This slide-switch is located next to the fiber optic connector. See diagram.

**Note: You must cycle power to the switch after changing the slide-switch position.**

**Top View of the  
5 port w/ fiber**

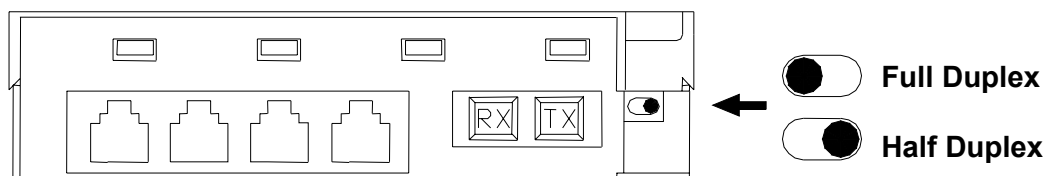

## Section 6

### Switching Features

## Switching Features

Here's a brief explanation of the features found in the Industrial Ethernet Switches documented by this manual.

### **10BaseT and 100BaseTx Autodetection**

Standard Ethernet (10BaseT) has a maximum speed of 10 Mbps (megabits per second). Fast Ethernet (100BaseTx) has a maximum speed of 100 Mbps. The RJ45 ports on the Industrial Ethernet Switches automatically support both types.

### **100BaseFX (multimode and singlemode) fiber optic port**

The fiber optic port found on some models is classified as 100BaseFX and supports 100 Mbps operation only. Both multimode and singlemode models are available. Multimode allows for multiple wavelengths over a cable with a core diameter of typically 50 or 62.5 microns. The maximum distance for multimode is 2 km. Singlemode uses a single wavelength and cable core diameter of around 10 microns which allows for a maximum distance of 15 km or more.

### **1.4 Gbps combined bandwidth**

With full duplex and 100BaseTX or 100BaseFX communications, each port can provide a full 200 Mbps of data throughput.

### **1K MAC addresses with automatic learning, aging and migration**

Each Ethernet device inserts its unique "MAC" address into each message it sends out. The port on the switch used for a given MAC address is automatically learned when a frame is received from that address. Once an address is learned, the switch will route messages to only the appropriate port, instead of broadcasting messages out all ports like a hub. A time stamp is also placed in memory when a new address is learned. This time stamp is used with the aging feature, which will remove unused MAC addresses from the table after 300 seconds. If a device moves, the associated port on the switch will be changed (migrated) as needed. Up to 1,024 MAC addresses can be stored and monitored at any time.

### **Auto-sensing speed and flow control**

The RJ45 ports of the Industrial Ethernet Switches will auto-negotiate with the connected device to determine the optimal speed (10 Mbps vs. 100 Mbps) and flow control for each port.

### **Automatic power saving**

If there is no cable on a port, most of the circuitry for that port is disabled to save power.

### **Backoff operation**

The Industrial Ethernet Switch will drop a packet after 16 collisions.

### **Back pressure for half-duplex**

The Industrial Ethernet Switch will apply "back pressure" when necessary with half-duplex operation. This "back pressure" will reduce congestion on busy networks.

### **Broadcast storm protection**

Broadcasts and multicasts are limited to 25% of the available bandwidth.

### **Buffering**

SRAM is used for buffering the messages. There are 1024 (128 bytes each) buffers available. Each port is allocated 205 buffers.

**Unmanaged operation**

The Industrial Ethernet Switch requires no supervisory processor to operate properly.

**Flow control**

The Industrial Ethernet Switch automatically supports flow control frames on both the transmit and receive sides.

**Forwarding**

The Industrial Ethernet Switch supports store and forward mode. It will forward messages with known addresses out only the appropriate port. Messages with unknown addresses, broadcast messages, and multicast messages will get forwarded out all ports except the source port. The Industrial Ethernet Switch will not forward error packets, 802.3x pause frames, or “local” packets.

**Full/Half duplex operation**

The RJ45 ports of the Industrial Ethernet Switch automatically support (auto-sense) both full and half duplex flow control. The fiber optic port has a slide-switch, which allows you to select the desired operation.

**Illegal frames**

Illegal frames as defined by IEEE 802.3 will be dropped. This includes short frames, long frames, and FCS error frames.

**IEEE 802.3 compliant**

The Industrial Ethernet Switch strictly abides to the IEEE 802.3 standard for 10BaseT and 100BaseTX Ethernet communications.

**Late collision**

If a packet experiences collisions after 512 bit times of transmission, the packet will be dropped.

**Plug and play**

This means that most functions or features of the Industrial Ethernet Switch are automatic and that there are minimal or no optional parameters that need to be set. Just plug in your Ethernet cables, apply power, and the unit will immediately begin to operate.

**Protocol independent**

The Industrial Ethernet Switch will work with all popular Ethernet protocols and networks such as TCP/IP, the Internet (IP), UDP, NetBEUI, and many more. It is compatible with all protocols that run over standard Ethernet (IEEE 802.3). In fact, it will support packets of different protocols simultaneously.

## Section 7

## Technical Specifications

### Technical Specifications

Here are the technical specifications for the Industrial Ethernet Switches covered by this manual.

<b>10/100BaseT(x) Ports:</b>	
10/100BaseT(x) ports	Shielded RJ45
Protocols supported	All standard IEEE 802.3
Ethernet compliancy	IEEE 802.3
Auto-sensing operation	Full and half duplex
Auto-negotiating	10BaseT and 100BaseTX
Flow control	Automatic
Ethernet isolation	1200 VRMS 1 minute
Plug and play	Yes
Cable requirements	Twisted pair (Cat. 5) (shielded recommended)
Max. cable distance	100 meters
<b>4+1 fiber port switch MM: (multimode)</b>	
100BaseFX ports	1
Fiber port mode	Multimode
Fiber port connector	Duplex SC
Optimal fiber cable	50/125, 62.5/125 $\mu$ m
Center wavelength	1300 nm
TX output power	-14 dBm to -22 dBm
RX input sensitivity	-31 dBm peak min.
Maximum distance	2 km on multimode fiber
Half and full duplex	Switch selectable
Ethernet compliance	100BaseFX
Eye safety	IEC 60825-1, Class 1; FDA 21 CFR 1040.10 and 1040.11
<b>4+1 fiber port switch SM: (singlemode)</b>	
100BaseFX ports	1
Fiber port mode	Singlemode
Fiber port connector	Duplex SC
Optimal fiber cable	9/125, 10/125 $\mu$ m
Center wavelength	1300 nm
TX output power	-8 dBm to -15 dBm
RX input sensitivity	-31 dBm peak min.
Maximum distance	15 km on singlemode fiber
Half and full duplex	Switch selectable
Ethernet compliance	100BaseFX
Eye safety	IEC 60825-1, Class 1; FDA 21 CFR 1040.10 and 1040.11

<b>General:</b>	
Forwarding mode	Store and forward
Memory bandwidth	1.4 Gbps
MAC addresses	1K
Address learning	Automatic
Address aging	Remove old address after 300s
Address migration	Automatic
Backoff operation	Drops after 16 collisions
Back pressure	Automatic for half-duplex
Broadcast storm protection	Limits to 25% of bandwidth
Buffering	113 (9port) or 205 (5port) buffers per port (128 bytes per buffer)
Illegal frames	Dropped per 802.3
Late collisions	Dropped after 512 bit times
<b>Environmental:</b>	
Required supply voltage	10 – 30 VDC
Power consumption	1.9 W (5port), 3.2 W (5 port fiber)
Power saving	Automatic
Max. screw terminal torque	5 port switch: 3.48 in-lbs (0.4 Nm). 4+1 fiber port switch: 5.3 in-lbs (0.6 Nm)
Max. wire gauge	12 AWG
Operating temp. range	-40 to 85 C
Storage temp. range	-40 to 85 C
Humidity	5 to 95 % (non-condensing)
Flammability	UL 94V-0 materials
Electrical safety	UL508, CSA C22/14; EN61010-1 (IEC1010), CE
EMI emissions	FCC part 15, ICES 003, EN55022; Class B; CE
EMC immunity	EN61326-1 (EN61000-4-2, 3, 4, and 6), CE
Surge withstand	IEEE-472 (ANSI C37.90)
Vibration	IEC68-2-6
Hazardous locations	UL1604, CSA C22.2/213 (Class 1, Div. 2), Cenelec EN50021 (Zone 2)
Dimensions	3.25" x 4.75"
Mounting	DIN rail or panel direct

## Section 8

**Service  
Information**

**Product  
Support**

## Service Information

Refer to the following sections of this manual when troubleshooting communication problems associated with a **ControlWave** Industrial Ethernet Real-time Switch:

Section 2 - LED Indicators

Section 4 - Power Wiring

Section 5 - Ethernet Wiring

During regular business hours, Bristol Babcock's Application Support Group can provide telephone support for your technical questions.

For technical assistance in troubleshooting a **ControlWave** Industrial Ethernet Real-time Switch call (860) 945-2244 or (860) 945-2286.

You can e-mail the Application Support Group at: **[bsupport@bristolbabcock.com](mailto:bsupport@bristolbabcock.com)**.

The Application Support Group also maintains a service area within our main web site. Technical information, as well as software updates are available in this area. To access our web site, go to [bristolbabcock.com/services/techsupport/](http://bristolbabcock.com/services/techsupport/).





# Customer Instruction Manual

## CI-ControlWaveIES

(Issue: 7/2001)



## Industrial Ethernet Real-time Switches

Bristol Babcock Inc.  
an FKI company

1100 Buckingham Street  
Watertown, CT 06795  
Telephone: (860) 945-2200