

Part D301737X012

March 2015

ControlWave[®] HART[®] Device Interface (HDI) Instruction Manual

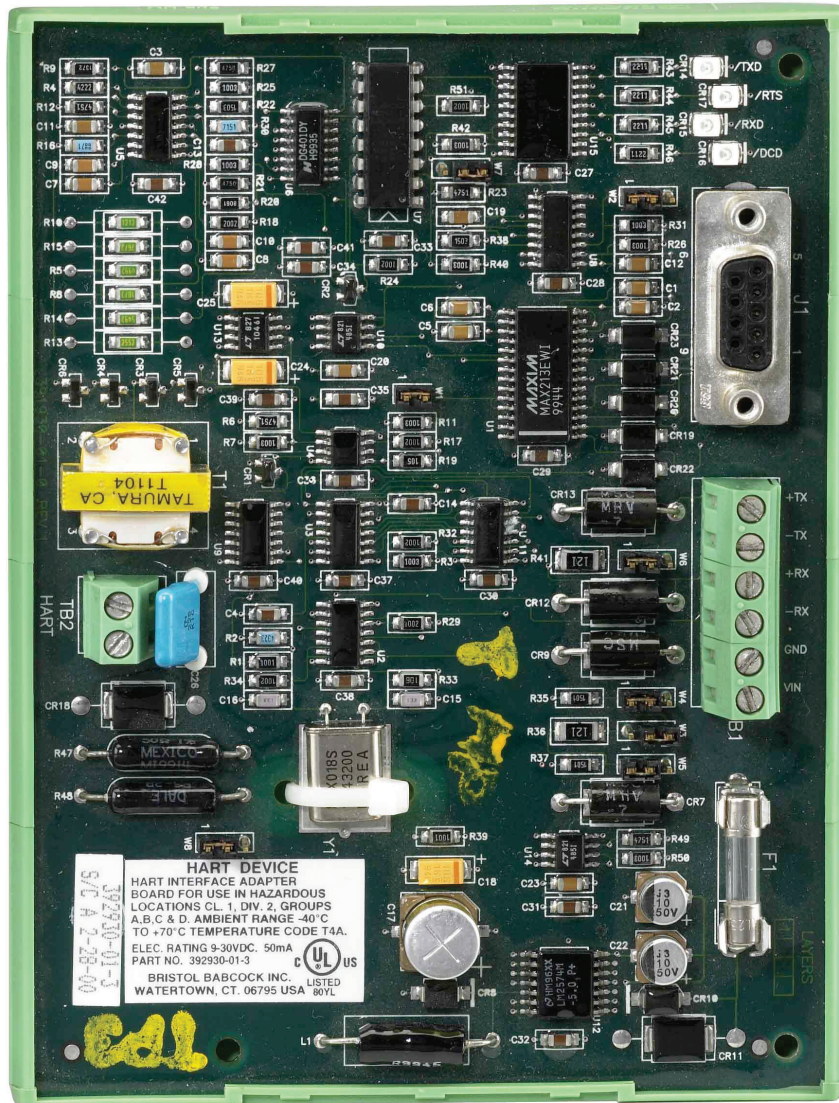

Remote Automation Solutions



EMERSON
Process Management

Revision Tracking Sheet

March 2015

This manual may be revised periodically to incorporate new or updated information. The revision date of each page appears at the bottom of the page opposite the page number. A change in revision date to any page also changes the date of the manual that appears on the front cover. Listed below is the revision date of each page (if applicable):

Page	Revision
2.5	Mar-15
Initial issue	May-13

Contents

Chapter 1 – General Information	1-1
<hr/>	
1.1 Scope of Manual	1-1
1.2 HDI Overview	1-1
1.3 Hardware	1-3
1.3.1 HDI Connectors	1-4
1.3.2 HDI Status LEDs	1-6
1.3.3 HDI Circuitry	1-6
1.4 Additional Technical Information	1-6
Chapter 2 – Installation and Use	2-1
<hr/>	
2.1 Installation Requirements	2-1
2.1.1 Restrictions and Assumptions	2-1
2.1.2 HART Remote Devices	2-2
2.2 Configuring a Single HDI	2-2
2.2.1 RS-485 Interface Communications	2-2
2.2.2 RS-232 Interface Communications	2-5
2.3 Configuring Multiple HDIs	2-7
2.3.1 RS-485 Interface Communications	2-7
2.3.2 RS-232 Interface Communications	2-9

[This page is intentionally left blank]

Chapter 1 – General Information

This manual describes the ControlWave[®] Highway Addressable Remote Transducer (HART[®]) Device Interface (HDI). This chapter provides an overview of the HDI and its components.

In This Chapter

1.1	Scope of Manual.....	1-1
1.2	HDI Overview	1-1
1.3	Hardware	1-3
1.3.1	HDI Connectors.....	1-4
1.3.2	HDI Status LEDs	1-6
1.3.3	HDI Circuitry	1-6
1.4	Additional Technical Information	1-6

1.1 Scope of Manual

This manual contains the following chapters:

Chapter 1 General Information	Provides an overview of the purpose and physical structure of the HART Device Interface (HDI).
Chapter 2 Installation and Use	Provides information on installing and using the HDI.

1.2 HDI Overview

The ControlWave HART Device Interface (HDI) enables HART remote devices or 3508 and 3808 transmitters to communicate with a Remote Automation Solutions ControlWave PAC, ControlWave Micro, or ControlWave Express RTU. The HDI supports both RS-232 and RS-485 interfaces. The interface to the field devices is provided by a jumper-selectable 249 ohm resistor in parallel with an AC coupled transformer. To support the protocol (Data Link Layer), you must define a HART function block and configure a host ControlWave communications port as a custom port in HART mode. The ACCOL3 Client function block supports RS-232-configured HDIs for communication with 3508/3808 transmitters. Each HDI can support up to 15 HART remote devices.

The HDI provides host/remote device communications, with the host originating each transaction, and remote devices generating replies only when prompted by the host. The HDI supports two hosts on a single link. The “primary host” is the normal control-system host. When required, you can define a hand-held communicator as the “secondary host” for maintenance purposes. Primary and secondary hosts must use **separate** addresses.



Figure 1. ControlWave HART Device Interface (HDI)

The HDI provides an RS-485/232 interface to a ControlWave RTU communications port, using a two-wire (voltage sourced or current sourced) connection to either a remote HART device or a 3508 or 3808 transmitter. Twisted-pair copper cable is used as the medium.

The HDI requires a 9-to-30 VDC bulk power supply. It supports RS-232 or RS-485 interfaces to the host ControlWave/RTU. For RS-232 communications, the HDI supports TXD, RXD, CTS, RTS, and CD signals. For RS-485 communications, the HDI supports +TXD, -TXD, +RXD, and -RXD signals. Interface to the field device is provided by a jumper-selectable 249 ohm resistor in parallel with an AC coupled transformer. During transmission, the FSK signal amplitude is between 400 to 600 mV with the average value of the FSK signal at 0 V. The HDI receiver input requires a signal that must be in the range of 120 mV to 1.5 V (peak-to-peak). The HDI ignores FSK signals from the field devices below 80 mV (peak-to-peak).

The HDI provides the following components and features:

- Selectable RS-232 or RS-485 interface to ControlWave RTUs
- Transformer-coupled communication interface to remote HART devices
- Operates from external 9-to-30 VDC power source
- Applicable with both HART remote devices and 3508/3808 transmitters. Both RS-232 and RS-485 communication modes are valid for HART remote devices. RS-232 mode is valid for both 3508s and 3808 transmitters.
- Conforms to HART[®] FSK Physical Layer Specification.

1.3 Hardware

The HDI is installed on a DIN rail mounting.

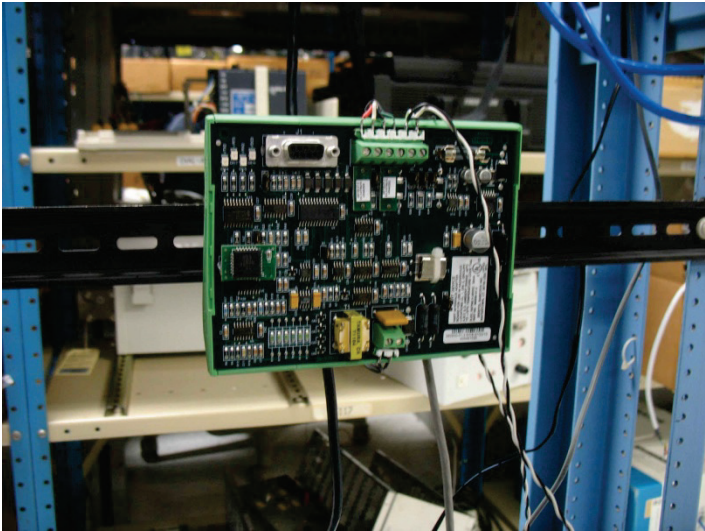

Figure 2. HDI mounted on a DIN rail

The HDI measures 5.56” long by 4.37” in high by 1.06” deep (see Figure 3).

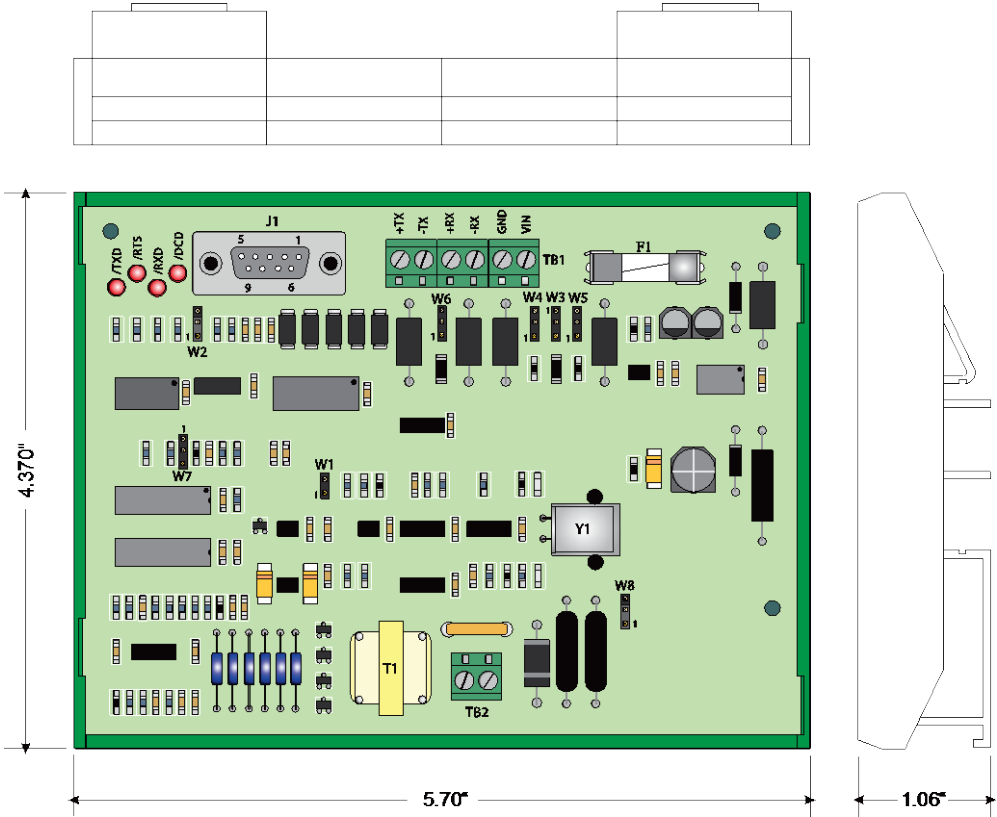

Figure 3. HART Device Interface (with plastic enclosure)

In addition to eight selectable jumpers and four status LEDs, the HDI provides three connectors.

1.3.1 HDI Connectors

The HDI provides the following connectors (see *Figure 4*):

- **J1**: a 9-pin D-type connector for the RS-232 interface (see *Table 1*)
- **TB1**: a 6-point terminal block for the RS-485 interface and input power (see *Table 2*)
- **TB2**: a 2-point terminal block for HART remote device connections (see *Table 3*)

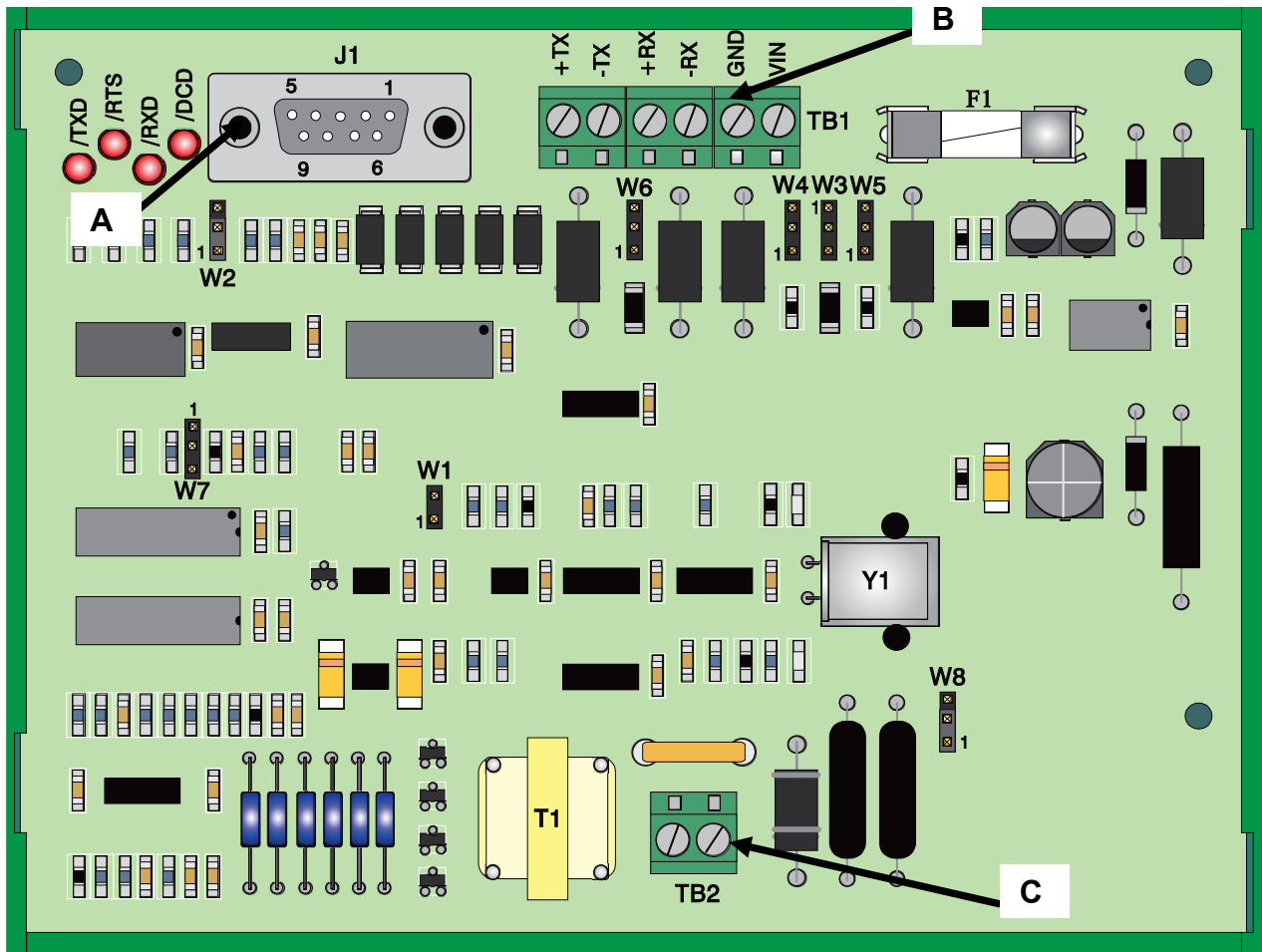

- A** J1; 9-pin D-type connector
- B** TB1; 6-point terminal block
- C** TB2; 2-point terminal block

Figure 4. HART Device Interface Circuit Board

Table 1. RS-232 Interface Connector J1 Signal Identification

PIN #	RS-232 signal	Signal description	DCE I/O
1	DCD	Data Carrier Detect	Output
2	/TXD	Transmit Data NOT	Input
3	/RXD	Receive Data NOT	Output
5	GND	Ground	-
6	CTS	Clear to Send	Output
7	RTS	Request to Send	Input

Table 2. Power & RS-485 Interface Connector TB1 Signal Identification

PIN #	Name	Description
1	VIN +9 - +28 VDC	Input Power (+)
2	GND	Power Ground (-)
3	- RXD	- TX Data from ControlWave
4	+RXD	+TX Data from ControlWave
5	- TXD	- RX Data to ControlWave
6	+TXD	+RX Data to ControlWave

Table 3. Remote Device Field Connector TB2 Signal Identification

PIN #	Field Connect
1	Field Loop (no polarity)
2	Field Loop (no polarity)

Table 4. HDI Jumper Identification and Assignment

Jumper #	Description	Pos. 1-2	Pos. 2-3
W1	RS-232 Mode	Disabled	N/A ¹
W2	3508 Mode (10 mS ON Delay)	Disabled	Enabled
W3	RS-485 Rcvr. 120 ohm Terminator ²	Enabled	Disabled
W4	RS-485 Rcvr. Positive Bias ²	Enabled	Disabled
W5	RS-485 Rcvr. Negative Bias ²	Enabled	Disabled
W6	RS-485 Xmtr. 120 ohm Terminator ²	Enabled	Disabled
W7	Status LED Enable	Enabled	Disabled
W8	249 Ohm Loop Resistor	Connected	Open

1 = W1 is a two-position jumper. When installed, it disables RS-232 and enables RS-485 communications; when removed, it enables RS-232 and disables RS-485 communications.

2 = Install on RS-485 End Node

1.3.2 HDI Status LEDs

The HDI provides four status LEDs (located in the upper left corner of the circuit board on *Figure 4*). You can disable the four LEDs by placing jumper W7 in position 2-3.

- CR14 = /TXD (Transmit Data NOT)
- CR15 = /RXD (Receive Data NOT)
- CR16 = /DCD (Data Carrier Detect NOT)
- CR17 = /RTS (Request to Send NOT).

1.3.3 HDI Circuitry

The HDI has a built-in $\pm 5V$ DC switching power supply that is fused and operates from a bulk 9-to-30 VDC power supply. A blocking diode protects the power supply circuitry from reversed input power conditions.

Independent RS-232 and RS-485 transceivers are jumper-selectable. A 120-ohm biasing resistor is jumper-selectable for the RS-485 transmit lines. A 120-ohm terminator and biasing resistors are jumper-selectable for the RS-485 receive lines.

When you configure the HDI to communicate with remote devices which support the HART protocol, and the communication mode between the HDI and the ControlWave device is RS-232. CTS NOT is asserted 100 microseconds after RTS NOT becomes valid. In the RS-485 mode, RTS NOT is generated by a 1 to 0 transition of TXD. For 3508 applications in RS-232 mode, a 10 millisecond RTS NOT to CTS NOT delay is selected to emulate the existing TIB design. The added combination of RTS232 NOT and RTS485 NOT enables the FSK modem's transmit circuitry, enables the CMOS switch to the transformer, and disconnects the receive signal to the FSK modem's receiver.

The FSK modem operates at Bell 202 standards with a 460.8 KHz clock.

RS-232 and RS-485 signals are transorb protected from surge transients and electrostatic discharge (ESD).

1.4 Additional Technical Information

Refer to the following technical documentation (available at www.EmersonProcess.com/Remote) for additional and most-current information:

Table 5. Additional Technical Information

Name	Form Number	Part Number
<i>ControlWave HART Device Interface Product Data Sheet</i>	CW:HDI	D301736X012
<i>HART Master Protocol Manual</i>	D40687	D301404X012

Chapter 2 – Installation and Use

This chapter provides generalized guidelines for the installation and operation of the HDI.

In This Chapter

2.1	Installation Requirements.....	2-1
2.1.1	Restrictions and Assumptions.....	2-1
2.1.2	HART Remote Devices.....	2-2
2.2	Configuring a Single HDI.....	2-2
2.2.1	RS-485 Interface Communications.....	2-2
2.2.2	RS-232 Interface Communications.....	2-5
2.3	Configuring Multiple HDIs.....	2-7
2.3.1	RS-485 Interface Communications.....	2-7
2.3.2	RS-232 Interface Communications.....	2-9

2.1 Installation Requirements

This section details the installation requirements of the HART Device Interface.

 **Caution** To avoid circuit damage when working inside the unit, use appropriate electrostatic discharge precautions (such as wearing a grounded wrist strap).

When working on units located in a hazardous area (where explosive gases may be present), make sure the area is in a non-hazardous state before performing procedures. Performing these procedures in a hazardous area could result in personal injury or property damage.

2.1.1 Restrictions and Assumptions

For multi-drop configurations, place the remote HART devices in a “digital” operation mode, setting the loop current for the device at 4mA or less. In receive mode, the host has an input impedance of 249 ohms. Use the following equation to determine the maximum number of field devices you can place in parallel with a 24V power supply:

$$\text{Maximum number of remote devices} = \frac{\{(24V - V(\text{Field device}) - [4mA \times 249 \times \#(\text{Field Devices})] - [4mA \times \#(\text{Field devices}) \times \text{Wire Resistance}] - 2V_{\text{loop}}\}}{4mA} > 0V$$

This calculation indicates that the HDI supports a maximum of **ten** transmitters (which require a minimum of 12V to operate in a loop), when the wire resistance is not included. If you intend to connect **more** than ten transmitters in parallel, the power supply voltage must **exceed** 24V.

Note: You can connect a maximum of 15 transmitters in parallel.

Field devices with a maximum ID number of 15 cannot be mixed with field devices with a maximum ID number of 2²⁴.

2.1.2 HART Remote Devices

HDI's configured for RS-232 communications can meet the Carrier On Delay value, but the Carrier Off Delay value may exceed the 5-bit time requirement (but the delay will be less than 12 bit times). HART remote devices are required to send a minimum of 5 preamble signals. The HDI's FSK modem can output receive data within 9 to 15 milliseconds after completing the transmit cycle. At 1200 baud, one character time is 11×0.833 milliseconds or 10 milliseconds. The remote device starts to transmit the preamble 10 milliseconds (one character time) after the end of the last character sent from the host device. The total delay from the end of the last character sent from the host to valid receive data is 25 milliseconds. Since there is a 1 character delay from the HDI, the receive communications driver synchronizes on the third preamble at the latest. The receive communications driver for the HART ACCOL3 function block requires one preamble before the start of data.

For HDI's configured for RS-485 communications, the Carrier Off Delay value is between 12 and 18 milliseconds (equivalent to 2 characters). The FSK modem takes 9 to 15 milliseconds to assert Carrier Detect (CD) and valid data. The total delay is 33 milliseconds. The remote device delays 9 milliseconds (one character time). The difference is $33 - 9.2 = 23.8$ milliseconds. This is about 2.6 characters. Two valid preambles will be seen by the receive communications driver for the HART ACCOL3 function block, which is sufficient before the start of data.

2.2 Configuring a Single HDI

This section details how to configure a single HDI.

2.2.1 RS-485 Interface Communications

Note: An RS-485 cable **cannot** exceed 4000 feet in length.

Follow steps 1 through 4 to configure a single HDI for RS-485 or HART interface operation.

1. Install the HDI in a suitable DIN rail mounted location. Connect the power supply (9-to-30 VDC) to TB1 so that pin 1 accepts the + Voltage and pin 2 is Ground.
2. Connect the HDI to the HART remote devices either as shown in *Figure 6* (for-to-20mA current sourced transmitters) or to a single HART remote device (for a +12 to +45 VDC voltage sourced transmitter) as shown in *Figure 7*.
3. Configure the selected ControlWave port for RS-485 operation (see the *HART Master Protocol Manual*, Document # D4068) and connect the selected port to TB1 of the HDI (see *Table 2* for HDI - TB1 designations) (see *Figure 5* for ControlWave D-Type RS-485 designations).

4. In ControlWave Designer, configure the HART function block in your ControlWave project and download the project to the ControlWave device. For information on HART function block configuration, see the online help in ControlWave Designer.

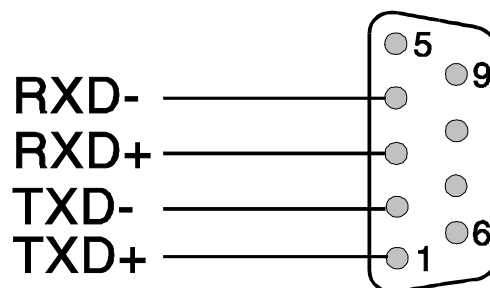

Figure 5. ControlWave RS-485 D-Type Port Assignment

5. Set the HDI jumpers:
 - Jumper W1 - RS-232 Mode - in position 1-2 (Disabled).
 - Jumper W2 - In position 1-2 (Disabled).
 - Jumper W3 - In position 1-2 (Enabled) places a 120 ohm termination resistor across the RS-485 receive lines.
 - Jumper W4 - RS-485 Receiver Positive Bias - position 1-2 = Enabled.
 - Jumper W5 - RS-485 Receiver Negative Bias - position 1-2 = Enabled.
 - Jumper W6 - In position 1-2 (Enabled) places a 120 ohm termination resistor across the RS-485 transmit lines.
 - Jumper W7 - In position 1-2 to Enable the Status LEDs, or position 2-3 to disable them.
 - Jumper W8 - In position 1-2 (Connected) - places a 249 ohm loop resistor into the Power Supply loop (for 4-20 mA Current Loop Transmitters). In position 2-3 for a voltage output slave device.

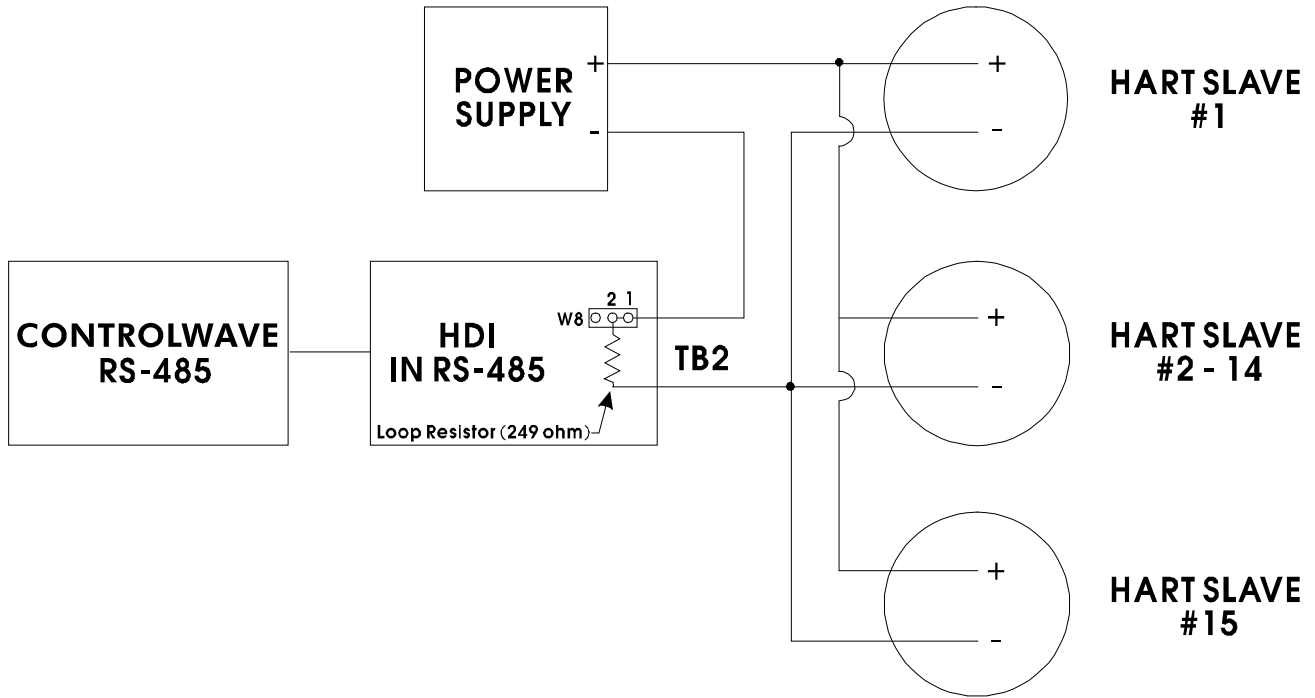

Figure 6. HART Remote Transmitters with 4-20 mA Current Source Connected to ControlWave Using an HDI in RS-485 Mode

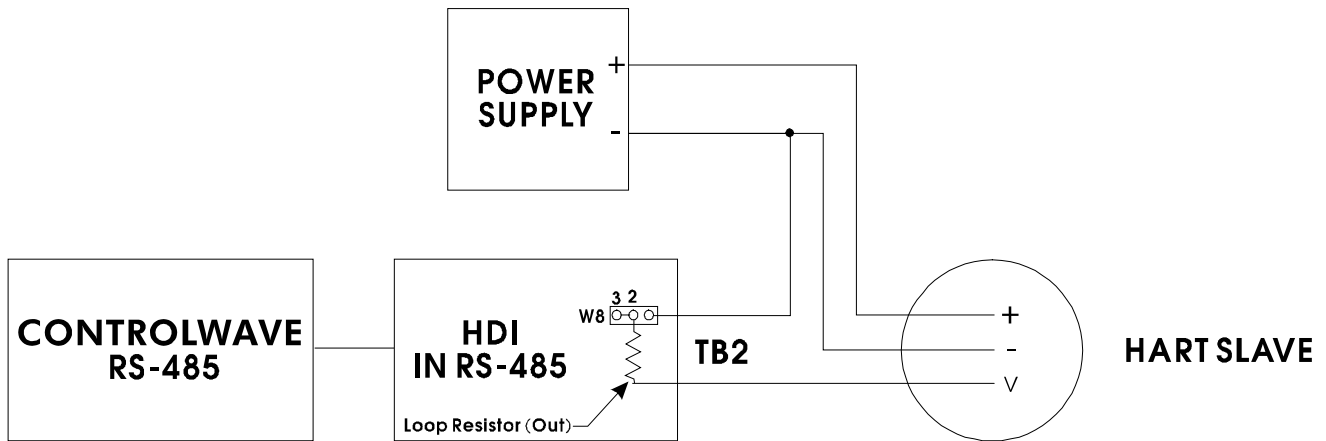

Figure 7. HART Remote Transmitters with +12 to +45 VDC Voltage Source Connected to ControlWave Using an HDI in RS-485 Mode

2.2.2 RS-232 Interface Communications

Follow steps 1 through 4 to configure a single HDI assembly for RS-232 operation:

Note: An RS-232 cable cannot exceed 25 feet in length.

1. Install the HDI in a suitable DIN rail mounted location. Connect the power supply (+9V to +30V DC) to TB1 as follows: Pin 1 = + Voltage, Pin 2 = Ground.
2. Connect the HDI to the HART remote devices as shown in *Figure 9* (for 4-20mA current sourced transmitters) or to a single HART voltage output slave device as shown in *Figure 10*.
3. In the Flash Configuration utility, configure the ControlWave serial port in question for the HART Protocol port type and connect the port to J1 of the HDI board (see *Table 1-1* for HDI - J1 designations). See *Figure 8* for ControlWave RS-232 cable designations. For instructions on how to access the Flash Configuration utility, refer to *Chapter 5* of the *OpenBSI Utilities (D5081)* manual.
4. In ControlWave Designer, configure the HART function block in your ControlWave project and download the project to the ControlWave device. For information on HART function block configuration, see the online help in ControlWave Designer.

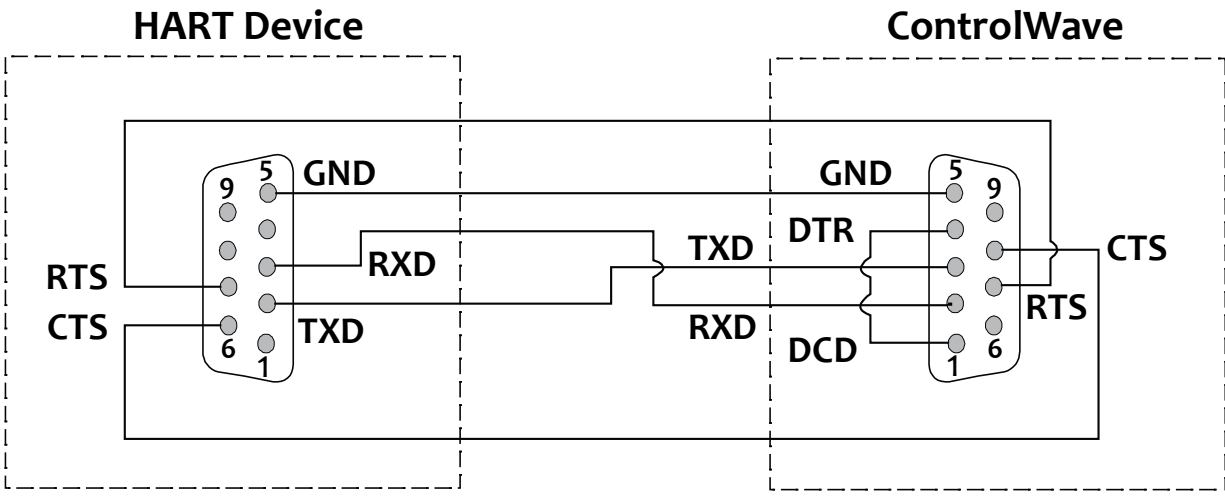

Figure 8. ControlWave RS-232 Cable

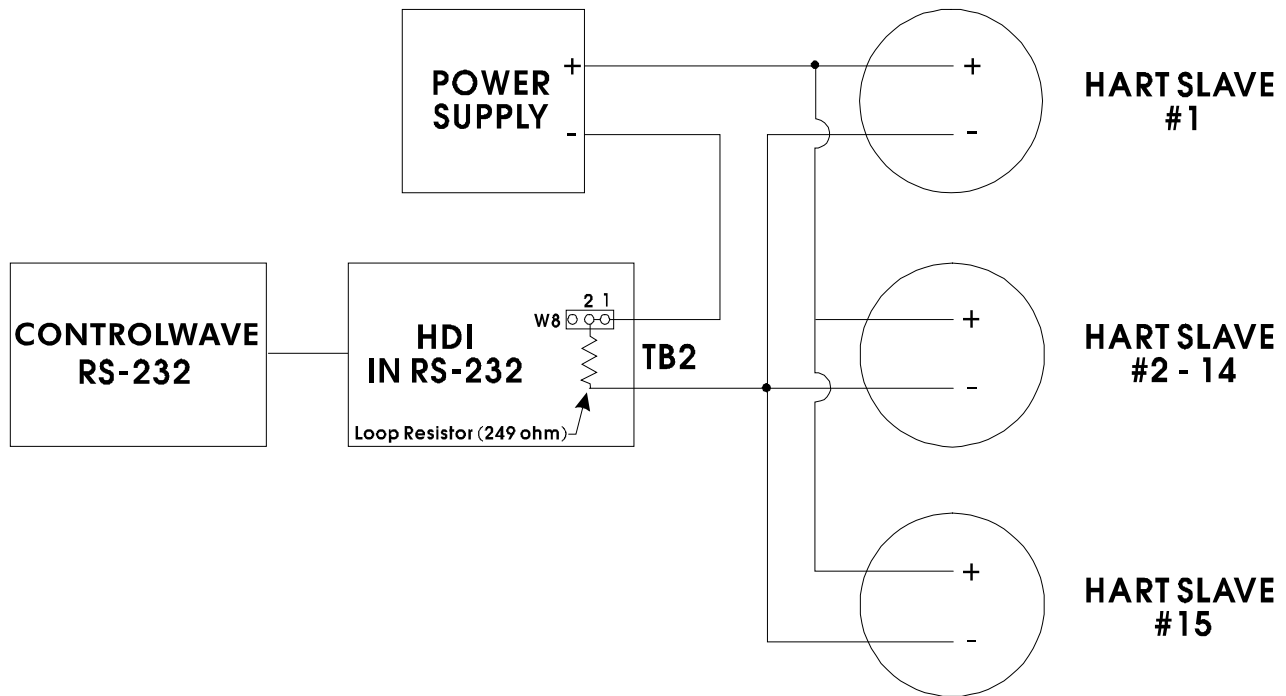

Figure 9. HART(Transmitters with 4-20 mA Current Source Connected to ControlWave using an HDI in RS-232 Mode

5. Set the HDI jumpers: :

- Jumper W1 - RS-232 Mode - stored in position 1 or 2 (Enabled).
- Jumper W2 - In position 2-3 (Enabled) for 3508 Mode - 10 millisecond delay. In position 1-2 (Disabled) - for all except 3508 Mode.
- Jumper W3 - In position 2-3 = Disabled.
- Jumper W4 - In position 2-3 = Disabled.
- Jumper W5 - In position 2-3 = Disabled.
- Jumper W6 - In position 2-3 = Disabled.
- Jumper W7 - In position 1-2 to Enable the Status LEDs, or position 2-3 to disable them.
- Jumper W8 - In position 1-2 (Connected) - places a 249 ohm loop resistor into the Power Supply loop (for 4-20 mA Current Loop Transmitters). In position 2-3 for a HART voltage output slave device.

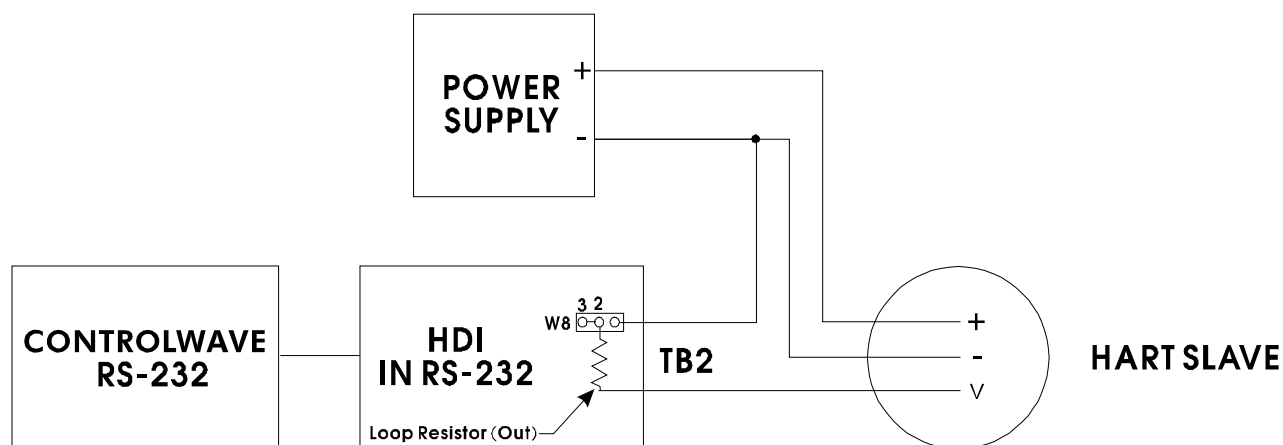

Figure 10. HART Transmitters (with +12 to +45 VDC Voltage Source Connected to ControlWave Using an HDI in RS-232 Mode)

2.3 Configuring Multiple HDIs

This section details how to configure multiple HDIs.

2.3.1 RS-485 Interface Communications

When using RS-485 communications, you can configure more than one HDI in conjunction with a single ControlWave port to support multiple groups of remote devices. (A single HDI can support up to 15 remote devices.)

Note: In this situation, both the ControlWave port and HDI must be configured for RS-485 communications.

Figure 11 shows an example of such a network. Depending on the type of transmitter, configure the HDI either for current source or voltage source, as described earlier.

Note: The maximum length of an RS-485 cable should not exceed 4000 feet.

Follow steps 1 through 5 to configure multiple HDIs for RS-485/HART interface operation:

1. Install each HDI in a suitable DIN rail mounted location. Connect the power supply (+9V to +30V DC) to TB1 as follows: Pin 1 = + Voltage, Pin 2 = Ground.
2. Connect each HDI to the HART remote devices as shown in Figure 6 (for 4-20mA current sourced transmitters) or to a single HART slave device as shown in Figure 7 (for a +12 to +45 VDC voltage output transmitter).

3. Configure the selected ControlWave port for RS-485 operation (see the HART Master Protocol Manual, Document # D4068) and connect the port in question to TB1 of the HDI board (see *Table 2* for HDI - TB1 designations) (see *Figure 5* for ControlWave D-Type RS-485 designations).

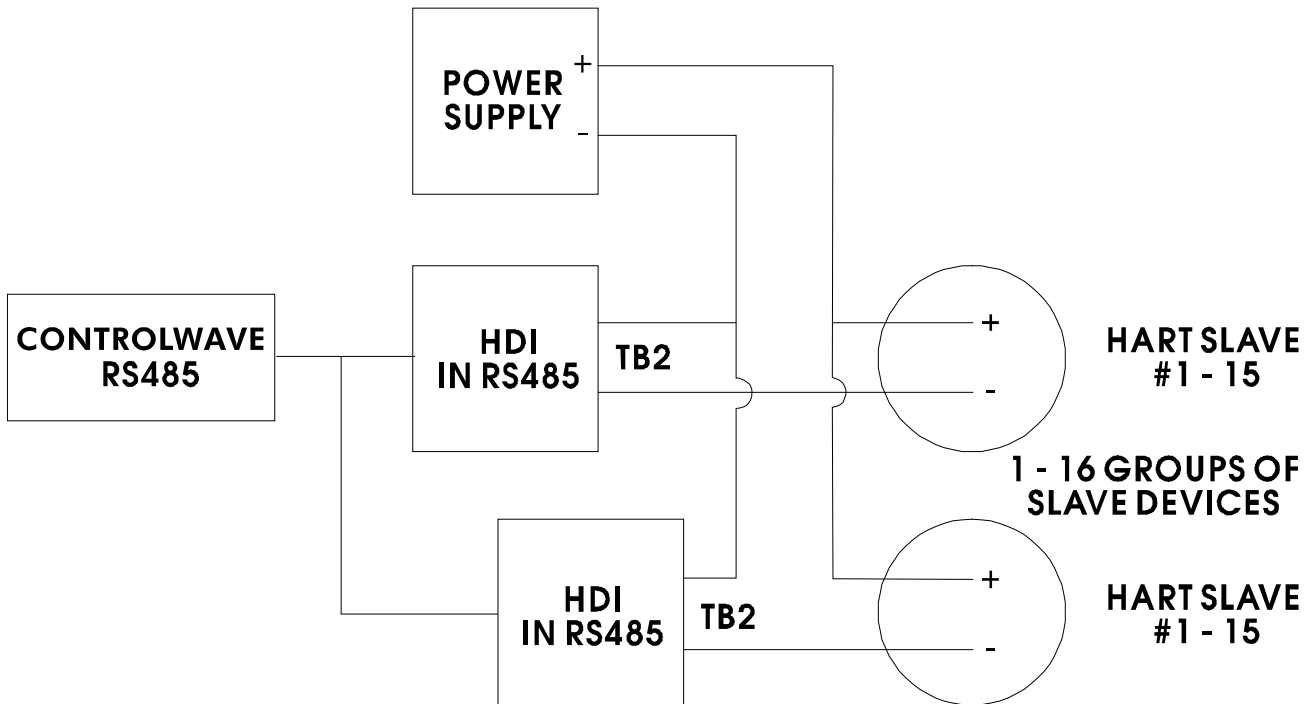

Figure 11. Multiple HDI Assemblies Connected to Multiple Groups of HART Transmitters

4. Set the HDI board jumpers:
 - Jumper W1 - Installed = RS-485 Mode Enabled.
 - Jumper W2 - In position 1-2.
 - Jumper W3 - In position 1-2 (Enabled) places a 120 ohm termination resistor across the RS-485 receive lines. Jumper W3 should be placed in position 1-2 for the most distant HDI board (End Node) and placed in position 2-3 (Disabled) for all other nodes.
 - Jumper W4 - RS-485 Receiver Positive Bias - position 1-2 = Enabled, position 2-3 = Disabled. Jumper W4 should be placed in position 1-2 for the most distant HDI board (End Node) and placed in position 2-3 (Disabled) for all other nodes.
 - Jumper W5 - RS-485 Receiver Negative Bias - position 1-2 = Enabled, position 2-3 = Disabled. Jumper W5 should be placed in position 1-2 for the most distant HDI board (End Node) and placed in position 2-3 (Disabled) for all other nodes.

- Jumper W6 - In position 1-2 (Enabled) places a 120 ohm termination resistor across the RS-485 transmit lines. Jumper W6 should be placed in position 1-2 for the most distant HDI board (End Node) otherwise in position 2-3 (Disabled).
- Jumper W7 - In position 1-2 to Enable the Status LEDs, or in position 2-3 to disable them.
- Jumper W8 - In position 1-2 (Connected) - places a 249 ohm loop resistor into the Power Supply loop (for 4-20 mA Current Loop Transmitters). In position 2-3 for a HART voltage output slave device.

2.3.2 RS-232 Interface Communications

When using RS-232 communications, you can configure only one HDI in conjunction with a single ControlWave port. Each ControlWave port can support up to 15 HART transmitters or up to five 3508s or 3808s.

If a single ControlWave device must communicate with multiple groups, wire the HDI associated with each group to a separate ControlWaveport, (that is, a port dedicated to the selected HDI and group). Depending on the type of transmitters, configure each HDI for either current source or voltage source, as described earlier.

Headquarters:

Emerson Process Management
Remote Automation Solutions
6005 Rogerdale Road
Houston, TX 77072 U.S.A.
T +1 281 879 2699 | F +1 281 988 4445
www.EmersonProcess.com/Remote

Europe:

Emerson Process Management
Remote Automation Solutions
Emerson House
Unit 8, Waterfront Business Park
Dudley Road, Brierley Hill
Dudley UK DY5 1LX
T +44 1384 487200 | F +44 1384 487258
www.EmersonProcess.com/Remote

North American/Latin America:

Emerson Process Management
Remote Automation Solutions
6005 Rogerdale Road
Houston TX USA 77072
T +1 281 879 2699 | F +1 281 988 4445
www.EmersonProcess.com/Remote

Middle East/Africa:

Emerson Process Management
Remote Automation Solutions
Emerson FZE
P.O. Box 17033
Jebel Ali Free Zone – South 2
Dubai U.A.E.
T +971 4 8118100 | F +971 4 8865465
www.EmersonProcess.com/Remote

Asia-Pacific:

Emerson Process Management
Remote Automation Solutions
1 Pandan Crescent
Singapore 128461
T +65 6777 8211 | F +65 6777 0947
www.EmersonProcess.com/Remote

© 2015 Remote Automation Solutions, a business unit of Emerson Process Management.
All rights reserved.

Remote Automation Solutions, a business unit of Emerson Process Management, shall not be liable for technical or editorial errors in this manual or omissions from this manual. REMOTE AUTOMATION SOLUTIONS MAKES NO WARRANTIES, EXPRESSED OR IMPLIED, INCLUDING THE IMPLIED WARRANTIES OF MERCHANTABILITY AND FITNESS FOR A PARTICULAR PURPOSE WITH RESPECT TO THIS MANUAL AND, IN NO EVENT SHALL REMOTE AUTOMATION SOLUTIONS BE LIABLE FOR ANY INCIDENTAL, PUNITIVE, SPECIAL OR CONSEQUENTIAL DAMAGES INCLUDING, BUT NOT LIMITED TO, LOSS OF PRODUCTION, LOSS OF PROFITS, LOSS OF REVENUE OR USE AND COSTS INCURRED INCLUDING WITHOUT LIMITATION FOR CAPITAL, FUEL AND POWER, AND CLAIMS OF THIRD PARTIES.

Emerson Process Management Ltd, Remote Automation Solutions (UK), is a wholly owned subsidiary of Emerson Electric Co. doing business as Remote Automation Solutions, a business unit of Emerson Process Management. FloBoss, ROCLINK, ControlWave, Helicoid, and OpenEnterprise are trademarks of Remote Automation Solutions. AMS, PlantWeb, and the PlantWeb logo are marks owned by one of the companies in the Emerson Process Management business unit of Emerson Electric Co. Emerson Process Management, Emerson and the Emerson logo are trademarks and service marks of the Emerson Electric Co. All other marks are property of their respective owners.

The contents of this publication are presented for informational purposes only. While every effort has been made to ensure informational accuracy, they are not to be construed as warranties or guarantees, express or implied, regarding the products or services described herein or their use or applicability. Remote Automation Solutions reserves the right to modify or improve the designs or specifications of such products at any time without notice. All sales are governed by Remote Automation Solutions' terms and conditions which are available upon request. Remote Automation Solutions does not assume responsibility for the selection, use or maintenance of any product. Responsibility for proper selection, use and maintenance of any Remote Automation Solutions product remains solely with the purchaser and end-user.