

September 2024

Type 63EGLP and 63EGLP-16 Relief Valve

WARNING

Failure to follow these instructions or to properly install and maintain this equipment could result in an explosion and/or fire causing property damage and personal injury or death.

Fisher™ relief valves must be installed, operated and maintained in accordance with federal, state and local codes, rules and regulations and Emerson Process Management Regulator Technologies, Inc. (Emerson) instructions.

If a leak develops or if the outlet continually vents process fluid, service to the unit may be required. Failure to correct trouble could result in a hazardous condition. Call a gas service person to service the unit. Only a qualified person shall install or service the unit.

Introduction

Scope of the Manual

This instruction manual provides instructions for the installation, maintenance and parts ordering information for a Type 63EGLP/63EGLP-16 Relief Valve with a Type 6358EBLP or 6358EBHLP Pilot.

Product Description

Main Valve Body

The Type 63EGLP/63EGLP-16 pilot operated pressure relief valve is used for vapor service on stationary LP-Gas or Anhydrous Ammonia (NH₃) bulk storage tanks only. The main valve uses a quick-change trim package for fast maintenance.

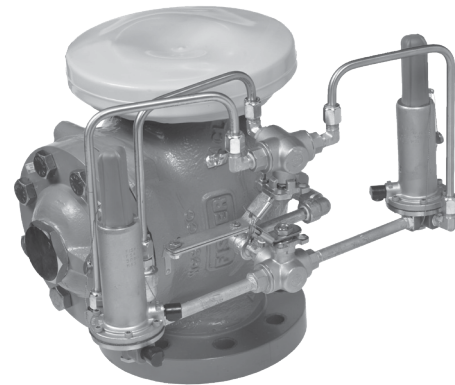

P1673_1

TYPE 63EGLP NPS 4 / DN 100 FLANGED VERSION



P3171

TYPE 63EGLP-16 2 MNPT VERSION

Figure 1. Type 63EGLP/63EGLP-16 Bulk Plant Relief Valve



6358EBLP_1

Figure 2. Type 6358EBLP Pilot

Type 63EGLP/63EGLP-16

Specifications

Specifications for the Type 63EGLP/63EGLP-16 construction is listed on Specifications section and Tables 1 to 3. The specifications for a given construction as it originally comes from the factory are stamped on nameplates located on the main valve body. The pilot valve set pressure appears on the pilot spring case.

Available Constructions

Type 63EGLP/63EGLP-16 with two
Type 6358EBLP Pilots
Type 63EGLP/63EGLP-16 with two
Type 6358EBHLP Pilots

Main Valve Body Size⁽¹⁾

Type 63EGLP: NPS 4 / DN 100
Type 63EGLP-16: 2 MNPT

End Connection Style

Type 63EGLP: CL300 RF, NPT
Type 63EGLP-16: MNPT

Maximum Relief Inlet Pressure⁽²⁾⁽³⁾

Type 63EGLP: 400 psig / 27.6 bar

Relief Set Pressure Ranges⁽²⁾

See Table 1a and 1b

Main Valve Port Diameter:

NPS 4 / DN 100, CL300 RF: 4.38 in. / 111 mm
2 NPT: 2.38 in. / 60 mm

Valve Plug Travel:

NPS 4 / DN 100, CL300 RF: 2.00 in. / 51 mm
2 NPT: 1.13 in. / 29 mm

Main Valve Flow Characteristic

Linear

Main Valve Flow Direction

Up through seat ring and out through cage

Main Valve Material

WCB Steel

Maximum Temperature Capabilities⁽²⁾⁽⁵⁾

Nitrile (NBR): -20 to 180°F / -29 to 82°C

Approximate Weights (including pilots)

NPS 4 / DN 100, CL300 RF: 178 lbs / 81 kg
2 NPT: 55 lbs / 25 kg

1. 4x3 in. flange reducer assembly available for 3 in. flange connections. See Parts List.

2. The pressure and/or temperature limits listed in this Instruction Manual and any applicable standard limitation should not be exceeded.

3. Includes buildup.

4. Set pressure is defined as the pressure at which the pilot (on UL® product) or the main valve (on ASME product) starts-to-discharge.

5. Product has passed Fisher™ performance testing for Start-to-Discharge and reseal at -40°F / -40°C.

Pilot Valve

The pilot valve regulator is responsible for the relief valve assembly's setpoint start-to-discharge pressure. The Type 63EGLP/63EGLP-16 Relief Valve uses a unique dual-pilot valve assembly that allows maintenance to one pilot while the alternate pilot continues to supply pressure to the main valve assembly, providing overpressure protection at all times when used correctly. The Type 63EGLP/63EGLP-16 Relief Valve utilizes one of two pilots: Type 6358EBLP or 6358EBHLP. Any Type 63EGLP shipped with certifications will use a specific version of the Type 6358EBLP pilot with required setpoint secured in place.

Principle of Operation

A pressure relief valve is a throttling pressure control device that opens and closes to ensure the upstream pressure does not rise above a predetermined pressure.

Refer to Figure 3. Type 63EGLP/63EGLP-16 Pressure Relief Valve with dual-pilot assembly has an active pilot and a standby pilot. Only the active pilot senses the changes in the inlet pressure. The handle assembly is always pointing away from the active pilot.

As long as the inlet pressure is below the set pressure, the pilot control spring keeps the pilot valve plug closed. Inlet pressure passes through the pilot restriction and through the hollow passage of the valve plug then registers as loading pressure on top of the main valve plug. Force from the main spring, in addition to pilot loading pressure, provides downward loading pressure to keep the main valve plug tightly closed.

When the inlet pressure rises above the set pressure, the pressure on the pilot diaphragm overcomes the control spring and opens the valve plug. The pilot then exhausts the loading pressure from the top of the main valve plug. The pilot continuously exhausts gas while inlet pressure is above the set pressure. The inlet pressure unbalance overcomes the main spring force and opens the plug.

Type 63EGLP/63EGLP-16

Table 1a. Type 63EGLP Bulk Plant Relief Valves Flow Rate for NPS 4 / DN 100 CL300 RF

TYPE NUMBER	CONTAINER CONNECTION	DISCHARGE SET PRESSURE		REPLACEMENT PILOT TYPE NUMBER	FLOW RATE, SCFM / SCMM OF AIR	
		psig	bar		Per UL®-132 ⁽¹⁾	ASME Sect VIII, Div. I ⁽²⁾
63EGLP-250	CL300 RF ⁽³⁾ , 4 in.	250	17.2	6358EBLP-250	38,794 / 1099	N/A
63EGLP-EB1		85 to 140	5.9 to 9.7	6358EBLP-1	N/A	11,929 to 47,164 / 338 to 1336
63EGLP-EB2		130 to 200	9.0 to 13.8	6358EBLP-2		
63EGLP-EB3		180 to 350	12.4 to 24.1	6358EBLP-3		
63EGLP-EBH		250 to 375	17.2 to 26.0	6358EBHLP		
63EGLP-NH3		180 to 350	12.4 to 24.1	6358EBLP-3		

1. Capacity recorded at 20% over set pressure.
2. Capacity based on 20% over set pressure. ASME Flow Rate (SCFM Air) = 111.78 x [(Set Pressure (psig) x 1.2) + 14.7] .
3. 4x3 in. flange reducer assembly available for 3 in. flange connections. See Parts List.
Note: Flow Capacity must be reduced if flange reducer assembled onto unit. Consult Emerson application engineers for flow rate reduction estimates.

Table 1b. Type 63EGLP-16 Bulk Plant Relief Valves Flow Rate for 2 MNPT

TYPE NUMBER	DISCHARGE SET PRESSURE		REPLACEMENT PILOT VALVE TYPE	LISTING / APPROVAL	FLOW RATE, AIR	
	psig	bar			SCFM	SCMM
63EGLP-16-250	250	17.2	6358EBLP-250	UL and ASME Sect VIII, Div. I	10,540 ⁽²⁾	298
63EGLP-16-EB1	85 to 140	5.9 to 9.7	6358EBLP-1	ASME Section VIII, Div. I	3,709 to 14,768 ⁽³⁾	105 to 418 ⁽³⁾
63EGLP-16-EB2	130 to 200	9.0 to 13.8	6358EBLP-2			
63EGLP-16-EB3	180 to 350	12.4 to 24.1	6358EBLP-3			
63EGLP-16-EBH	250 to 375	17.2 to 26.0	6358EBHLP			
63EGLP-16-NH3	180 to 350	12.4 to 24.1	6358EBLP-3			

1. All are 2 NPT units with male union coupling included for inlet connection during installation.
2. Capacity based on 20% over set pressure, UL-132 Standard.
3. Capacity based on 20% over set pressure. ASME Flow Rate (SCFM Air) = 31.78 x [(Set Pressure (psig) x 1.2) + 14.7] .

Table 2. Relief Set Pressure Ranges

TYPE	PILOT TYPE	RELIEF SET PRESSURE RANGE ⁽¹⁾		SPRING PART NUMBER	SPRING COLOR	SPRING WIRE DIAMETER		SPRING FREE LENGTH	
		psig	bar			In.	mm	In.	mm
63EGLP	6358EBLP	85 to 140	5.9 to 9.6	17B1261X012	Green	0.225	5.72	3.70	94.0
		130 to 200	9.0 to 13.8	17B1263X012	Blue	0.262	6.66	3.85	97.8
180 to 350		12.4 to 24.1	17B1264X012	Red	0.294	7.47	4.22	107	
	6358EBHLP	250 to 375	17.2 to 25.9	17B1263X012	Blue	0.262	6.66	3.85	97.8

1. Set pressure plus buildup should not exceed maximum differential pressure of 400 psig / 27.6 bar.

Table 3. Minimum and Maximum Differential Pressure

BODY SIZE	MAIN VALVE SPRING RANGE		MAIN VALVE SPRING PART NUMBER	MAIN VALVE SPRING COLOR	TYPE 63EGLP			
					Minimum Differential Pressure Required For Full Stroke		Maximum Differential Pressure	
	psig	bar			psig	bar	psig	bar
NPS 4 / DN 100	85 to 375	5.9 to 25.9	14A6634X012	Red	55	3.8	400	27.6
2 NPT	85 to 375	5.9 to 27.6	14A6628X012	Red	90	6.2	400	27.6

Type 63EGLP/63EGLP-16

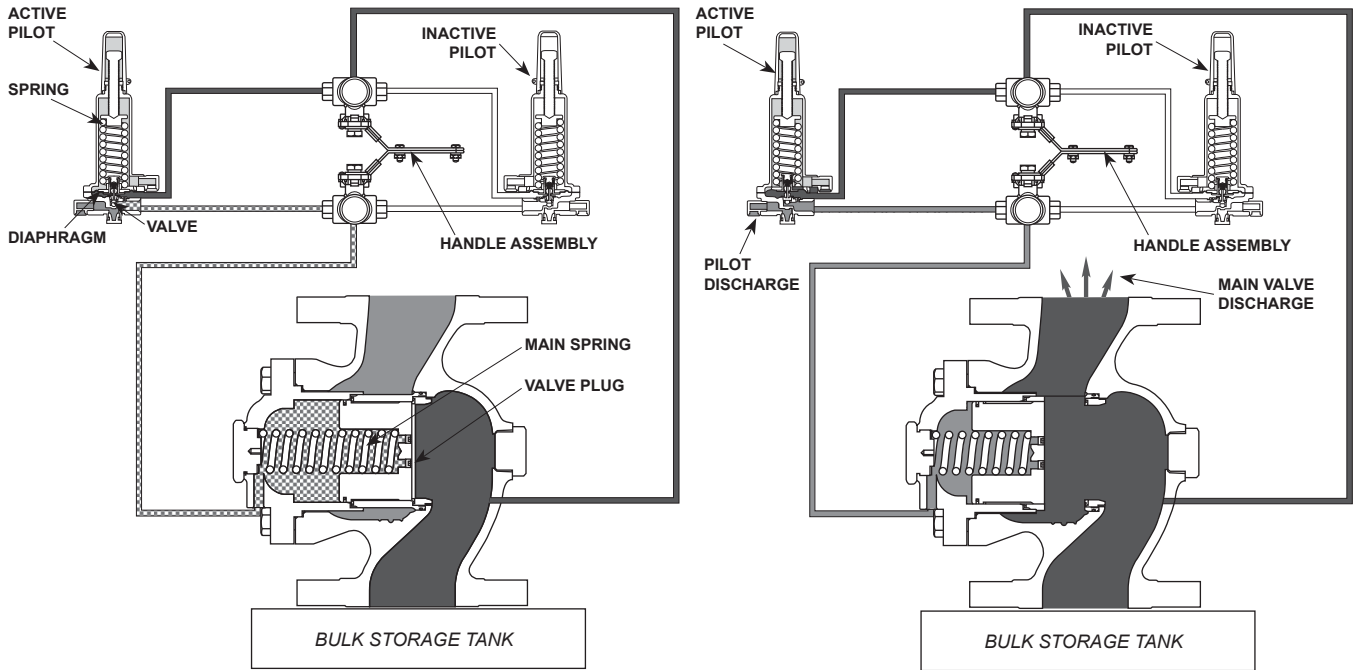

TYPE 63EGLP AT NORMAL CONDITION
(BOTH MAIN VALVE AND ACTIVE PILOT ARE CLOSED)

TYPE 63EGLP AT OVERPRESSURE CONDITION
(ACTIVE PILOT DISCHARGES LOADING PRESSURE, MAIN VALVE DISCHARGES EXCESS INLET PRESSURE)

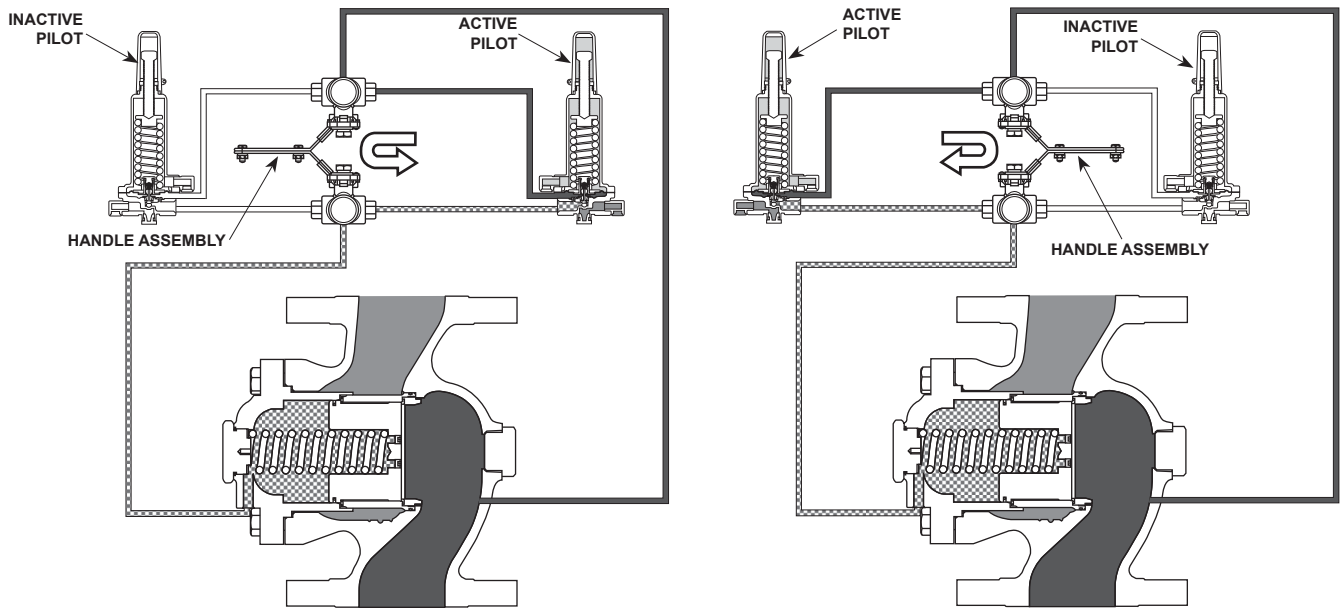

HANDLE ASSEMBLY IS ALWAYS POINTING AWAY FROM THE ACTIVE PILOT.
ROTATION OF HANDLE ALLOWS CHANGING OF ACTIVE PILOT.

- INLET PRESSURE
- OUTLET (EXHAUST) PRESSURE
- ATMOSPHERIC PRESSURE
- ▨ LOADING PRESSURE

NOTE: TYPE 63EGLP OPERATIONAL SCHEMATICS THE SAME FOR TYPE 63EGLP-16.

Figure 3. Type 63EGLP Operational Schematics

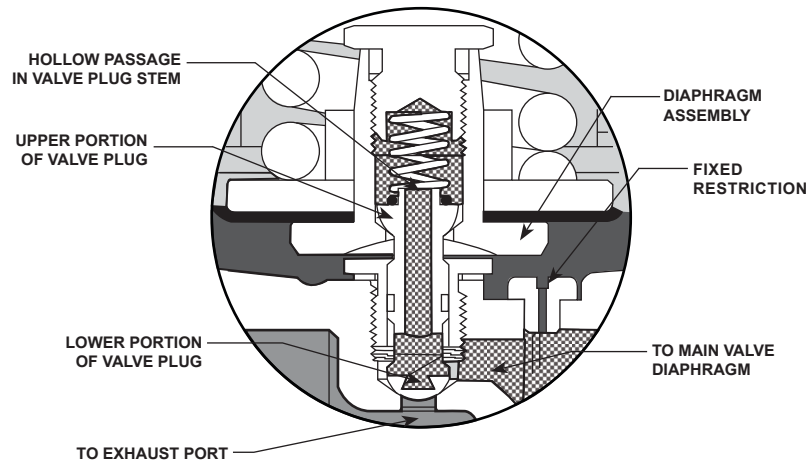

EXPANDED VIEW OF THE TYPE 6358EBLP RELIEF PILOT DIAPHRAGM ASSEMBLY AND VALVE PLUG

- INLET PRESSURE
- OUTLET (EXHAUST) PRESSURE
- ATMOSPHERIC PRESSURE
- LOADING PRESSURE

Figure 4. Type 6358EBLP Operational Schematics

As the inlet pressure drops below the set pressure, the pilot control spring closes the pilot valve plug and the pilot exhaust to atmosphere stops. Force from the main spring, along with pilot loading pressure, pushes the plug onto the seat, producing tight shutoff.

Additionally, physical damage to the relief valve could break the pilot off the main valve, causing personal injury and property damage due to escaping gas. To avoid such injury or damage, install the unit in a safe location.

Installation



WARNING

Personal injury, equipment damage or leakage due to escaping gas or bursting of pressure-containing parts may result if the relief valve is installed where its capabilities can be exceeded or where conditions exceed any ratings of the adjacent piping or piping connections.

To avoid injury or damage, install a Type 63EGLP/63EGLP-16 Relief Valve where:

- **Service conditions are within unit capabilities (including those given in the Specifications section)**
- **Service conditions are within applicable codes, regulations or standards**

1. Call a qualified personnel and use proper equipment when installing, operating and maintaining relief valves. Before installing, inspect the main valve, pilot and tubing for any shipment damage or foreign material that may have collected during crating and shipment. Make certain the body interior is clean and the pipelines are free of foreign material.
 - To install a flanged body (Type 63EGLP), use suitable line gaskets and good bolting practices. Main body gasket and studs and nuts are not included. To order, see parts list.
 - To install an MNPT body (Type 63EGLP-16), use suitable thread sealant and good threading practices. Please ensure hex nipple (Key 48) between valve body and tank is tightened with appropriate tools. Thread sealants are not included.

Type 63EGLP/63EGLP-16

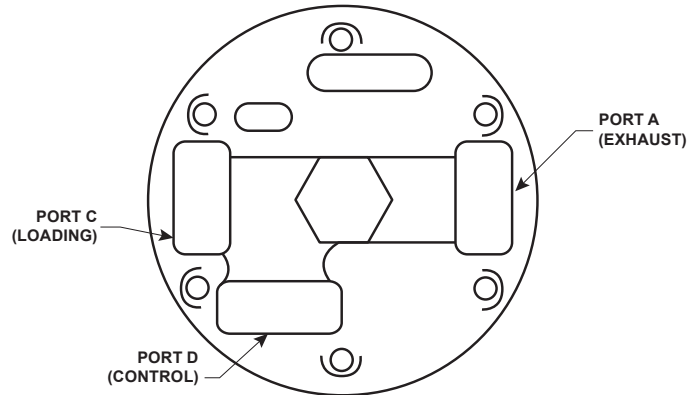

PORT A (EXHAUST)—THE MAIN VALVE LOADING PRESSURE IS DISCHARGED TO THE MAIN VALVE OUTLET OR TO ATMOSPHERE PRESSURE.
 PORT C (LOADING)—A LOADING PRESSURE SIGNAL IS SENT FROM THIS PORT TO THE MAIN VALVE DIAPHRAGM CASING.
 PORT D (CONTROL)—THE MAIN VALVE INLET PRESSURE IS SENSED AT THIS PORT.

Figure 5. Pilot Port Functions (bottom view)

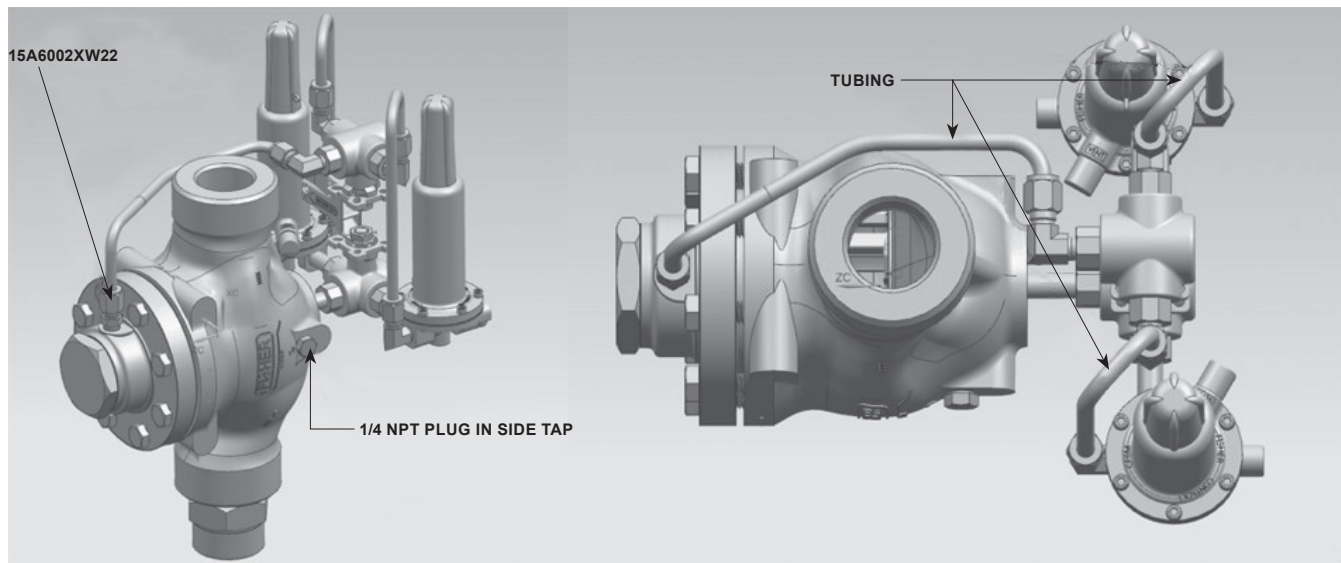

TYPE 63EGLP-16 WITH TOP VIEW FOR 2 MNPT

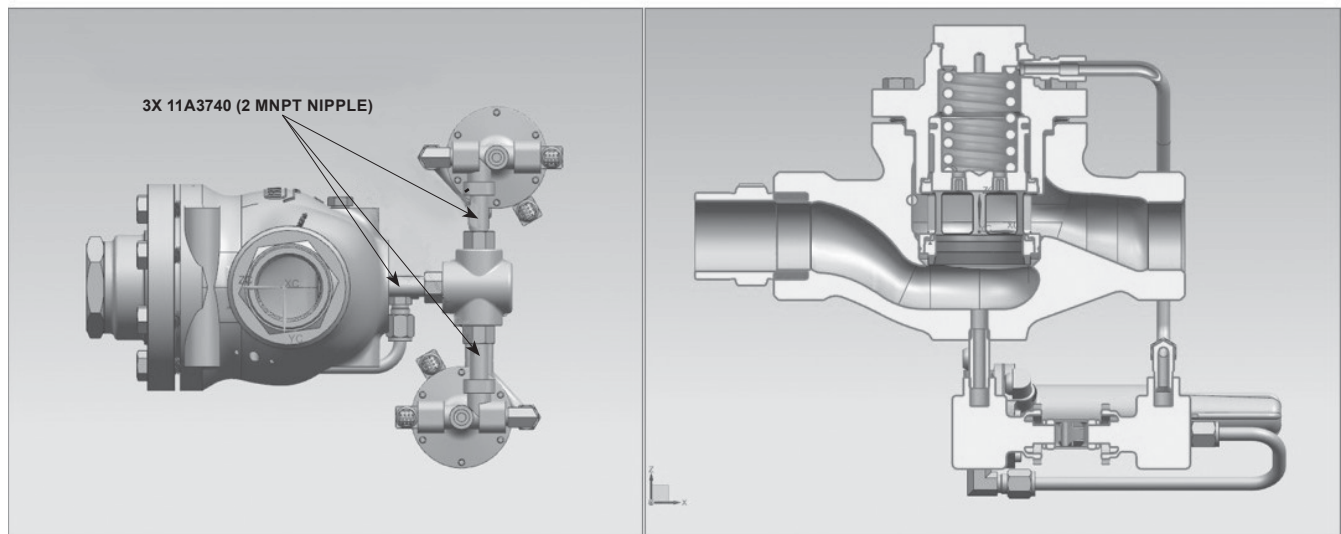

TYPE 63EGLP-16 BOTTOM WITH INTERNAL SECTION FOR 2 MNPT

Figure 6. Type 63EGLP-16, 2 NPT

- For Type 63EGLP: Use the lifting sling (key 50) wrapped around outlet flange (as shipped) to lift the Type 63EGLP when installing the unit. After installing the valve on the tank, install rain cap (key 51) on outlet flange. Ensure that the valve is in the vertical-up orientation with flow through it matching the direction of the arrow on the main valve body. An upstream control line is not required because of the integral pilot supply tubing.
For Type 63EGLP-16: Carefully lift the Type 63EGLP-16, avoid lifting by the pilot assembly. After installing the valve on the tank, ensure the valve is in the vertical-up orientation with flow through it matching the direction of the arrow on the main valve body. Exercise care to ensure that the hex nipple (key 48) at the valve body is not cross threaded with tank coupling. An upstream control line is not required because of the integral pilot supply tubing.



WARNING

Type 63EGLP/63EGLP-16 Relief Valves vent gas from the main valve outlet and from the pilot exhaust. In hazardous or flammable gas service, personal injury, death or property damage may occur due to fire or explosion of accumulated vented gas.

To prevent such injury or damage, vent the gas to a safe location. Design and install exhaust piping to guard against excessive flow restriction. Protect the pilot vent and exhaust piping from condensation or debris that can clog it.

- If system operation is necessary during maintenance or inspection, one pilot valve can be isolated while the other pilot valve actively loads the main valve body to continuously protect the system. If service to the main valve body is required, remove the upstream pressure.
- Install a relief valve so that the pilot will exhaust properly and into a safe place. The pilot spring case vent must be kept open to atmospheric pressure. Protect this vent from icing, moisture or other blockage as required. If the vent assembly (key 16) remains in the pilot exhaust port (connection A, Figure 5), it must be pointed down if possible or otherwise protected.
- If the exhaust is to be piped to the main valve outlet or remotely vented, remove the vent assembly and install obstruction-free tubing or piping with a minimum number of bends into the 1/4 NPT pilot exhaust connection. Provide protection on a remote vent by installing a screened vent cap into the remote end of the vent pipe.
- If using pipe, apply a good grade of pipe compound to the male pipe threads before making the connection. Install tubing or piping into the appropriate pilot connection.
- The set pressure of a unit is adjusted by changing the control spring compression on the pilot valve.
- The pilot valve is factory-set for the pressure set-point specified on the order. Some certifications require the adjusting assembly be protected from tampering and will come factory-installed with a tamper-evident wire seal. These units are not adjustable.

Dual Pilot-Valve Active Monitoring

The Type 63EGLP/63EGLP-16 Pressure Relief Valve with dual-pilot assembly is shipped from the factory with the handle assembly, (key 48), pointing to one pilot valve or the other. In this operating mode, it has an active pilot and a standby pilot. Only the active pilot senses the changes in the inlet pressure. The handle assembly is always pointing away from the active pilot.

The Type 63EGLP/63EGLP-16 Bulk Storage Relief Valve can be adjusted for use with BOTH pilot valves active, by placing the 3-way ball valve selector handle (key 48) in the middle position. When the 3-way selector valve handle is in the middle position, then both pilot valves are in an active mode to sense tank (upstream) pressure and will operate normally for start-to-discharge and reseal of the main valve.

While operating in this mode with the 3-way selector valve handle in the middle position, even if one pilot valve's exhaust discharge port is blocked and unable to discharge loading pressure, the alternate pilot will continue to actively sense upstream (tank) pressure and begin to discharge loading pressure per its set-point. This allows the main valve body to begin to relieve tank pressure at the alternate pilot valve's set-point.

The attached figure represents the pilot valve assembly and 3-way selector ball valve handle in the above described middle position.

To check for proper positioning and orientation of the 3-way selector valve in the middle position, see Figures 7, 8 and 9 for the location of the "T" symbol on the small valve stem of both 3-way ball valves. The small "T" symbol on the ball valve stems must indicate the same direction and flow path to all 3 valve ports on a given 3-way valve, while the handle assembly (key 48) is in the middle position.

Type 63EGLP/63EGLP-16

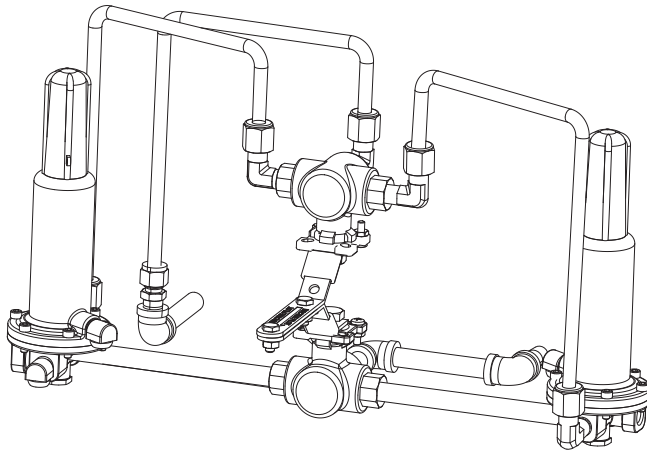

NOTE: TYPE 63EGLP-16 THE SAME CONSTRUCTION WITH A SMALLER HANDLE.

Figure 7. Type 63EGLP with Dual Pilot-Valve Active Monitoring, Center Handle Position

Startup and Adjustment

The relief valve is factory set at the set-point pressure requested. With proper installation completed, slowly increase pressure while using gauges to monitor pressure.

Adjustment

Certain configurations or approvals require the pilot to be secured from adjustment. For assemblies allowing adjustment, key numbers are referenced in Figure 13. To adjust relief set pressure of Type 6358EBLP relief pilot, perform the following procedures.

1. Remove the closing cap (key 12) and loosen the locknut (key 11).
2. Turn the adjusting screw (key 10) clockwise to increase or counterclockwise to decrease the relief set pressure.
3. Introduce pressure to the relief valve slightly higher than the desired relief set pressure. Monitor inlet pressure to the relief valve with a pressure gauge. The relief valve should start releasing excess pressure as soon as the inlet pressure to the relief valve exceeds the desired relief set pressure.
4. If the desired relief set pressure is achieved, tighten the locknut to lock the adjusting screw and install the closing cap.
5. Apply wire seal or other adjustment protection if available.

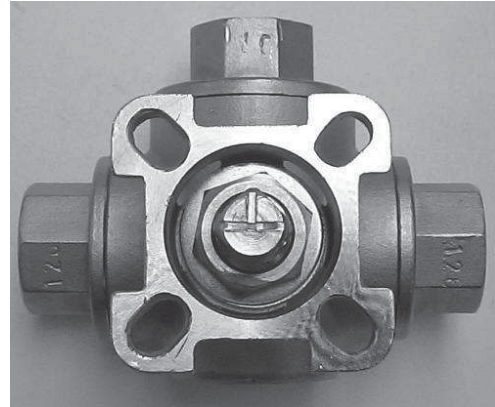

Figure 8. Type 63EGLP 3-Way Ball Valve Stem Check

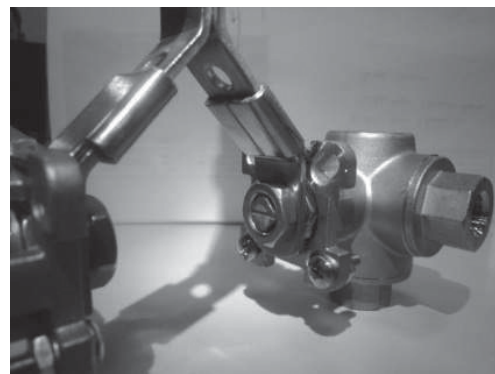

Figure 9. Type 63EGLP 3-Way Ball Valve Stem Check in Dual-Pilot Active Monitoring

Shutdown

1. Remove all pressure from the upstream system or tank.
2. Release all pressure from the main valve and pilot by opening an upstream vent valve or by slightly loosening one of the compression fittings on the pilot supply tubing or actuator tubing until the trapped pressure starts bleeding out.
3. Once all pressure is released, finger tighten the compression fitting, then use appropriate wrench to turn the nut to 1/4 turn.

Maintenance

Relief valve parts are subject to normal wear and must be inspected and replaced as necessary. The frequency of inspection and replacement of parts depends upon the severity of service conditions or the requirements of local, state and federal regulations.

Visually inspect the physical condition of the relief valve at least once a year to check if there are leaks or damage to the relief valve. If the relief valve or pilots show any visible damage, corrosion, evidence of tampering (UL® listed valves have a wire seal on both pilots to prevent tampering) or if water, dirt or debris is found in the discharge side of the relief valve, the valve must be cleaned, repaired and retested or replaced immediately.

Inspect the drain hole of any debris/obstructions. Clear any debris/obstructions that may be present for they can prevent proper drainage from the valve body. If the drain hole cannot be cleared, replace the relief valve. Observe the rain cap (key 51) periodically ensuring it is free of damages and has a snug fit. If the cap shows sign of damages (i.e. tears) or no longer on the valve outlet flange, inspect the unit and replace the cap. The cap helps protect the relief valve against possible malfunction caused by the outside elements.

It is recommended to switch the lever/handle assembly yearly to activate alternate pilot. It is also recommended to replace both pilots valves every 10 years (5 years for NH₃ Applications). Since the elastomer seals in a relief valve are subject to normal deterioration, Fisher™ recommends that a relief valve not be used for longer than 15 years without repair, retest or replacement. Earlier repair or replacement may be required due to severe service conditions or code requirements. If external leakage is observed from piping, couplings, or fittings during inspection, remove the valve from tank. Repair and retest or replace the entire relief valve immediately. If internal leakage is observed from the relief valve during inspection, the main seals should be replaced and the relief valve retested or the relief valve replaced immediately.

Retesting may include:

- a.) Testing both pilot valves for start-to-discharge;
- b.) Testing the valve for internal or by-pass, leakage.

The test for leakage can be done by spraying the outlet with soap solution and observe for bubbles. If bubbles are present then the valve will be to be repaired or replaced as necessary. A more accurate test involves the use of a gas leak detector device. Use this device by placing it around the outlet of the valve. If the device detects a gas leak, replace the main seals or entire valve as necessary.

Main seal replacement within the main body is only required if the valve does not pass a leakage test. If the main seals maintain a bubble-tight seal then they do not require replacement. At 15 years from the valve's date of manufacturing or before, the valve would have to be tested for main valve seat leakage. If there is no leakage the valve can remain in service without having to depressurize the tank or replace the main valve body.

Note

During testing or leak checking of a given pilot valve, confirm the lever/handle is completely pointed toward the inactive pilot. Do not have it pointed toward the active pilot or in between the two pilots.

Due to the care Emerson takes in meeting all manufacturing requirements (heat treating, dimensional tolerances, etc.), use only replacement parts manufactured or furnished by Emerson.

Lubricate all O-rings, gaskets and seals with a good grade of general-purpose grease and install gently rather than force into position. Update nameplates to accurately indicate any field changes in equipment, materials, service conditions or pressure settings.

Types 63EGLP-16-NH3 and 63EGLP-NH3 (for Anhydrous Ammonia Service) follow the same maintenance recommendations outlined in this instruction manual. Please refer to Compressed Gas Association (CGA 6.2.1) Codes for any additional maintenance requirements or your Authority Having Jurisdiction.



WARNING

To avoid personal injury and equipment damage, isolate the valve from all pressure. Cautiously release pressure from the valve before attempting disassembly.

Type 63EGLP/63EGLP-16 Dual-Pilot Valve Assembly

To Change Out A Pilot

Note

This section only applies to Type 63EGLP/63EGLP-16 assemblies received with two pilots. If your assembly only has one pilot, refer to section *To Install an Additional Pilot*. Replacing one of the two pilots requires the following tools and Fisher™ Key Numbers:

- **Wrench Sizes (recommend open-ended or adjustable): 11/16 in.**
- **Required Fisher Key Numbers (QTY): Matching Type 6358EBLP or 6358EBHLP Pilot (x1)**
- **Option Key Numbers (QTY): 49 (x2)**

To easily identify the active pilot, check the direction of handle assembly. The handle assembly is always pointing away from the active pilot. See Figure 3.

CAUTION

Only apply thread sealant to Male NPT threads. Sealant applied to female pipe connections or to compression fittings could inhibit the seal and result in a leak or product contamination.

1. The Type 6358EBLP pilot ships preassembled with a 1/4 in.-by-Compression elbow (key 43, Figure 15) oriented in the correct direction in Port C (Figure 5). If your pilot does not have this elbow installed, please contact your local Fisher LP-Gas Distributor to obtain the correct part.

CAUTION

A small amount of vapor release may occur during steps 2 through 4. If the main valve or alternate pilot continuously vents while conducting steps 2 through 4, return the handle to the previous position and contact your local LP-Gas distributor.

2. Locate the wire seal securing the sliding lock mechanisms on the ball valve handle and remove it. The wire seals are factory installed to discourage tampering from untrained professionals and must be replaced upon completion.
3. The 3-way ball valves are factory-equipped with positive stops to prevent over-rotation. In the event these stops have been removed, do not over-rotate the handle assembly as this may cause improper valve operation. Slowly rotate the handle assembly (key 48) of the 3-way valves until the handle assembly points to the pilot that will be removed. The handle assembly should be oriented such that the sliding handle locks are capable of sliding into place.
4. Gently loosen the 11/16 in. compression fitting securing the stainless steel line to the inactive pilot to bleed off trapped pressure.

CAUTION

If excessive amounts of process fluid continue to discharge out of the fitting, secure the fitting and confirm the ball valve handle orientation is correct.

If the orientation is correct and you are unable to completely depressurize the inactive pilot, contact your local LP-Gas distributor for additional support as the ball valve assembly may need to be replaced.

5. Once the inactive pilot is completely depressurized, remove the compression fitting and move the stainless steel tube out of the way.

Note

Loosening the compression fitting on the other end of the tube may make this step easier.

6. Hold the remaining pipe nipple (key 36) in place with a pipe wrench and remove the pilot.
7. Clean the exposed pipe nipple and apply new thread sealant before threading the new pilot onto the nipple. Make sure the pipe wrench is utilized to secure the pipe nipple. Install the pilot such that the pipe nipple threads into Port D. Continue tightening until snug, tightening further until the pilot adjusting screw points in the same direction as the outlet of the main valve body.
8. Re-attach the 11/16 in. compression fitting assembly on the stainless tube connecting the pilot and 3-way ball valve. Finger tighten the compression fitting assembly, then use appropriate wrench to turn the nut 1/4 turns (assuming the ferrule is already clamped to the tube).
9. Slowly reverse step 3, taking note of the preceding cautions. Once the handle assembly points away from the newly installed pilot, the new pilot should be active and pressurized. Perform a leak check on all connections and fittings.
 - a. At this time you may choose to continue using the new pilot as the main control pilot or rotate the handle assembly to utilize the alternate pilot as the main control pilot.
10. The reserve pilot should be purged of pressure to prolong service life and minimize the risk of vapor reliquefying in the pilot and the piping. Refer to step 4 to properly purge the reserve pilot. After purging the reserve pilot, finger tighten the compression fitting, then use appropriate wrench to turn the nuts to 1/4 turn. Install the wire seals.

To Install an Additional Pilot

Note

This section only applies to Type 63EGLP/63EGLP-16 assemblies received with one pilot. If your assembly has two pilots, skip to section *To Change Out a Pilot*. Installing the additional pilot requires the following tools and Fisher™ Key Numbers:

- **Wrench Sizes (recommend open-ended or adjustable):** 9/16 in., 11/16 in. and 7/8 in.
 - **Pipe Wrench:** recommend maximum length: 12 in.
 - **Required Fisher Key Numbers (QTY):** 36 (x1), 43 (x1), 44 (x1), Matching Type 6358EBLP Pilot (x1)
 - **Fisher Key Numbers (QTY):** 49 (x2)
1. The Type 6358EBLP pilot ships preassembled with a 1/4 in.-by-Compression elbow (key 43, Figure 15) in Port C oriented in the same direction as the spring case. If your pilot does not have this elbow installed, please contact your local Fisher LP-Gas Distributor to obtain the correct part.
 2. Confirm that the handle assembly is pointing AWAY from the ACTIVE pilot. The handle assembly has a sliding lock mechanism that is wire sealed at the factory before shipment. If the wire seal has been damaged or is missing, proceed with caution.

CAUTION

Product may be trapped between the 3-way valve seal and the pipe plugs. Use caution when proceeding to step 3.

3. Secure the first 3-way valve with an appropriate 7/8 in. wrench. Using an appropriate 9/16 in. wrench, slowly remove the 1/4 NPT pipe plug. If any pressure is trapped between the 3-way valve and the plug, it should quickly dissipate. If pressure continues to bleed, reinstall the plug and contact your authorized Fisher LP-Gas Distributor as the 3-way valve may need replacing.
4. Repeat step 3 on the remaining 3-way valve.

CAUTION

Only apply thread sealant to Male NPT threads. Sealant applied to female pipe connections or to compression fittings could inhibit the seal and result in a leak or product contamination.

5. Clean the FNPT threads on the 3-way valves. Apply thread sealant to one end of the 6 in. Male NPT pipe nipple (key 36) and install the pipe nipple into the lower 3-way valve Female NPT connection. Tighten it in place with an appropriately size pipe wrench.
6. Apply thread sealant to the Male NPT end of one of the 1/4 in.-by-Compression elbows (key 43). Using an appropriate 5/8 in. wrench, install the compression fitting in the Female NPT outlet of the upper 3-way valve until snug, tightening until the compression fitting is facing in the same direction as the main valve outlet.
7. Apply thread sealant to exposed end of the 6 in. Male NPT pipe nipple. To install the new pilot, thread pilot Port D onto the pipe nipple until snug, tightening until the spring case and compression fitting are oriented in the same direction as the main valve outlet.
8. Orient the stainless steel tubing (key 44) to connect the compression fitting on the pilot to the compression fitting on the 3-way valve. Finger tighten the compression fitting assembly, then use appropriate 11/16 wrench to turn the nut 1/4 turns (assuming the ferrule is already clamped to the tube).

CAUTION

A small amount of vapor release may occur during steps 10 and 11. If the main valve or alternate pilot continuously vents while conducting steps 10 or 11, return the handle to the previous position and contact your local LP-Gas distributor.

9. Locate the wire seals securing the sliding lock mechanisms on the 3-way valve handle and remove them. The wire seals are factory installed to discourage tampering from untrained professionals and should be replaced upon completion.

Type 63EGLP/63EGLP-16



Figure 10. Replacing Trim Parts on Site Using Body as Holding Fixture

10. The 3-way ball valves are factory-equipped with positive stops to prevent over-rotation. In the event these stops have been removed, do not over-rotate the handle assembly as this may cause improper valve operation. Slowly rotate the handle assembly (key 48) of the 3-way valves until the handle assembly points away from the newly installed pilot. The handle assembly should be oriented such that the sliding handle locks are capable of sliding into place. Once the handle assembly points away from the newly installed pilot, the new pilot should be active and pressurized. Perform a leak check on all connections and fittings.
 - a. At this time you may choose to continue using the new pilot as the main control pilot or rotate the handle assembly to utilize the alternate pilot as the main control pilot.
11. The reserve pilot should be purged of pressure to prolong service life and minimize the risk of vapor reliquefying in the pilot and the piping. Gently loosen the 11/16 in. compression fitting securing the stainless steel line to the inactive pilot to bleed off trapped pressure. After purging the inactive pilot, finger tighten the compression fitting, then use appropriate wrench to turn the nuts to 1/4 turn. Install the wire seals.

Type 63EGLP/63EGLP-16 Main Valve Body

CAUTION

The Main Valve Assembly can only be repaired or modified where local codes or restrictions allow. Check with your LP-Gas distributor or local Authority Having Jurisdiction for information on restrictions that may apply.

Replacing Trim Sealing Parts

Perform this procedure if inspecting, cleaning or replacing individual parts in the trim package, by using Repair Kit Part No. R63EGLPX012. Key numbers for the Type 63EGLP/63EGLP-16 Main Valve are referenced in Figure 11.

Note

All disassembly, trim sealing parts change and reassembly steps in this section may be performed with the relief valve still connected to the upstream piping, if upstream pressure is removed. The pilot and its pipe nipple must be removed with the Type 63EGLP/63EGLP-16 Main Valve.

Access to the spring (key 9) or flange O-ring (key 21) in step 1 can be gained without removing the body flange (key 2).

Type 63EGLP/63EGLP-16

1. Remove the pilots and pilot pipe nipples from the valve body. Remove the body flange plug (key 27) and the spring (key 9) and attached parts.
2. Remove the cap screws (key 3) and pry the body flange (key 2) loose from the valve body (key 1).
3. Use the valve body as a holding fixture if desired. Flip the body flange over and anchor it on the valve body as shown in Figure 10, removing the pipe plug (key 31) first if necessary.
4. To gain access to the port seal (key 12), upper seal (key 15) or valve plug parts, unscrew the seat ring (key 13) from the cage (key 11) and the cage from the body flange (key 2). For leverage, a wrench handle or similar tool may be inserted into the orifice slots (Figure 10) and a strap wrench may be wrapped around the cage or a soft bar may be inserted through the windows of a standard cage. To remove the piston ring (key 14) and/or plug O-ring (key 20), remove the valve plug (key 16) from the body flange, insert a screw-driver into the pre-cut fold over area of the piston ring and unfold the piston ring.

Note

Installing parts without lubrication or overtightening parts may affect shutoff.

5. Replace and lightly lubricate the gasket (key 4), cage O-ring (key 17), port seal (key 12) and upper seal (key 15). Ensure that port and upper seals are installed in their retaining slots with the grooved sides facing out. Also lubricate any other surfaces as necessary for ease of installation. For proper operation, a Type 63EGLP valve plug must have pipe plugs (key 31) installed in all four balancing ports.

Note

When tightening threaded parts together, use a method of tightening, backing off and tighten again until the union is snug.

6. Remove and replace the plug O-ring (key 20) and piston ring (key 14) onto the valve plug (key 16). Insert the valve plug into the body flange (key 2), install the cage (key 11) plus upper seal (key 15) and cage O-ring (key 17) into the body flange and then install the seat ring (key 13) plus port seal (key 12) into the cage. Use the valve body as a holding fixture during this step as shown in Figure 10 and insert a wrench handle or similar tool into the orifice slots for leverage when tightening the orifice and cage.

Note

When installing the main valve Repair Kit, align the body flange and valve body side tappings.

7. Remove the upside-down body flange (key 2) if it was anchored on the body. Lightly lubricate the cage seating surfaces of the valve body web and the body flange. Install the body flange on the body (key 1) and secure it evenly with the cap screws or stud bolts (key 3). With a Type 63EGLP main valve, reinstall the 3-way valve and its pipe nipple and connect the pilot tubing.

Type 63EGLP/63EGLP-16 Main Valve Cap Screw (key 3) Torque

SIZE	TORQUE	
	Ft-Lbs	N•m
NPS 4 / DN 100	160 to 200	217 to 271
2 MNPT	55 to 70	75 to 95

8. Install the spring (key 9). Remove and replace the flange O-ring (key 21) on the flange plug (key 27). Install the flange plug; if necessary, compress the spring enough to ensure secure engagement of plug and body flange threads before final tightening of the plug.

Parts Ordering

Each Type 63EGLP/63EGLP-16 Relief Valve is assigned an FS number which can be found on the nameplates. Refer to this number when contacting your local Sales Office for assistance or when ordering replacement parts.

When ordering a replacement part, be sure to include the complete 11-character part number. Separate kits containing all recommended spare parts are available for both the main valve and pilot.

*Recommended spare part.

1. Contact factory for details. Gasket and bolts and nuts are not included. Valve to reducer bolts and nuts mounting kit: MK63EGLP002. 3 in. Spiral Wound Gasket: T1056138992.

Type 63EGLP/63EGLP-16

Parts List

Main Valve Body (Figure 11)

Key	Description	Part Number
	Main Valve Parts kit (included are keys 4, 12, 14, 15, 17, 20 and 21)	R63EGLPX012
	Tank to Valve studs and nuts mounting kit (not included)	MK63EGLP001
	4 in. Spiral Wound Gasket (not included)	ERSA03240A0
1	Valve Body, WCB Steel	ERAA02116A0
2	Body Flange CF8M Stainless steel, ENC, heat-treated	24A9032X012
3	Cap Screw, Zinc-plated steel (8 required)	1A485724052
4*	Gasket, composition	14A5650X082
9	Spring, Steel	14A6634X012
11*	Cage, Linear, heat-treated Stainless steel	34B5840X012
12*	Port Seal, Nitrile (NBR)	24A5643X062
13*	Seat Ring, 416 Stainless steel	24A5640X012
14*	Piston Ring Polytetrafluoroethylene (PTFE) (Clear)	14A5645X022
15*	Upper Seal, Nitrile (NBR)	24A5644X062
16*	Valve Plug, heat-treated 416 Stainless steel	24A8182X012
17*	Cage O-ring, Nitrile (NBR)	10A3481X082
20*	Plug O-ring, Nitrile (NBR)	14A5688X132
21*	O-ring, Nitrile (NBR)	10A3800X162
24	Drive Screw, Stainless steel (2 required)	1A368228982
25	Flow Arrow, Stainless steel	1V105938982
26	Nameplate	-----
27	Plug (not used with optional travel indicator) Zinc-plated steel	14A9684X012
31	Pipe Plug, Plated steel (4 required)	1E823128982
45	Pipe Plug, Carbon steel (not shown)	1A398524182
46	Deflector, Plated-Carbon steel (not shown)	T13091T0012
47	Drive Screw, Plated-Carbon steel (2 required) (not shown)	1A676728992

Type 63EGLP for 2 NPT (Figure 12)

Key	Description	Part Number
1	2 NPT Body	ERAA49242A0
2	Body Flange	25A2254X012
3	Cap Screw	1A453324072
4	Gasket	14A5685X112
9	Spring	14A6628X0A0
11	Cage	GF03319X012
12	Portal Seal, lower, Nitrile (NBR)	24A5673X022
13	Seat Ring, 416 Stainless steel	24A5670X012
14	Piston Ring	14A5675X112
15	Port Seal, upper, Nitrile (NBR)	24A5674X022
16	Valve Plug, 416 Stainless steel	24A6772X012
17	O-ring, Cage, Nitrile (NBR)	10A7779X062
20	O-ring, Plug, Nitrile (NBR)	14A5686X062
21	O-ring, Plug, Nitrile (NBR)	10A3800X162
27	Plug	14A9684X242
31	Pipe Plug, 416 Stainless steel	1E823128982
45	Pipe Plug	1A767524662
48	Male Hex Coupling	ERAA51789A0

Types 6358EBLP and 6358EBHLP Pilot Valves (Figure 13)

Key	Description	Part Number
1	Pilot Body, CF8M Stainless steel	39A5972X012
2	Spring Case, Stainless steel	27B9722X012
3	Body Plug, Stainless steel	1B7975X0052
4*	Valve Plug Assembly, Stainless steel	18B3427X072
5*	Diaphragm Assembly, Type 6358EBLP, Nitrile (NBR) 85 to 200 psig / 5.8 to 13.8 bar	18B3428X012
	180 to 350 psig / 12.4 to 24.1 bar	18B3428X082
	Type 6358EBHLP, Nitrile (NBR)	18B3429X012
6	Connector Cap, Stainless steel	14B9813X012
7	Control Spring Type 6358EBLP 85 to 140 psi / 5.8 to 9.7 bar	17B1261X012
	130 to 200 psi / 9.0 to 13.8 bar	17B1263X012
	180 to 350 psi / 12.4 to 24.1 bar	17B1264X012
	Type 6358EBHLP 250 to 450 psi / 17.2 to 27.6 bar	17B1263X012
8	Spring Seat, Zinc-plated steel	17B0515X012
9	Stem Guide, Stainless steel	16A2923X012
10	Adjusting Screw Type 6358EBLP 85 to 140 psi / 5.8 to 9.7 bar	17B1261X012
	130 to 200 psi / 9.0 to 13.8 bar	17B1263X012
	180 to 350 psi / 12.4 to 24.1 bar	17B1264X012
	Type 6358EBHLP 250 to 450 psi / 17.2 to 27.6 bar	17B1263X012
11	Locknut	1D667728982
12	Closing Cap, Plastic	24B1301X012
13*	Body Plug O-ring, Nitrile (NBR)	1F113906992
14	Valve Spring	1E701337022
15	O-ring	10A7777X012
16	Vent Assembly (2 required)	Type Y602X1-A12U
17	Machine Screw (6 required) (not shown) Type 6358EBLP	1V4360X0022
	Type 6358EBHLP	T12980T0012
18	Connector Cap O-ring, Nitrile (NBR)	10A0904X042
20	Restriction, High Gain	17A7279X012
36*	Gasket, Nitrile (NBR)	1U1716X0062
37	Stem O-ring, Nitrile (NBR)	16A2920X072
38	Lower Spring Seat	18B1248X022
40	Diaphragm Limiter for Type 6358EBLP at 180 to 350 psig / 12.4 to 24.1 bar	10B4407X012

Type 63EGLP/63EGLP-16

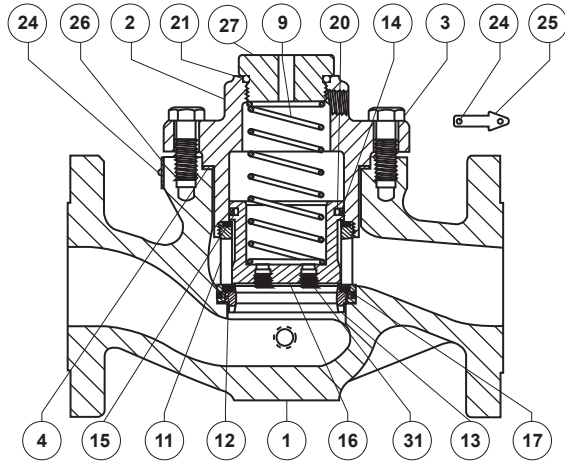

35A3174-A

COMPLETE STEEL MAIN VALVE ASSEMBLY

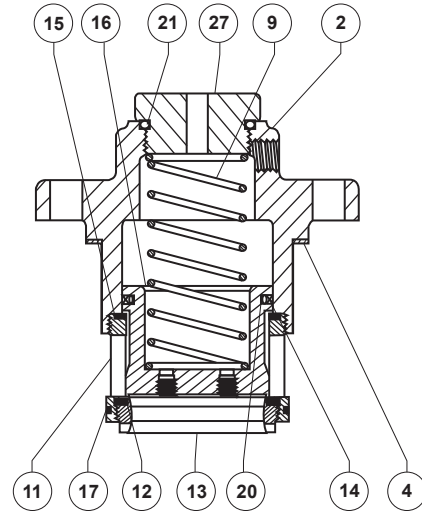

25A3169_B

TRIM PACKAGE ASSEMBLY

Figure 11. Type 63EGLP Main Valve Trim Package

Type 63EGLP, NPS 4 / DN 100, CL300 RF Mounting Parts (Figure 14)

Key	Description	Part Number
	Flange Reducer 4X3 in. CL300 RF for 3 in. flange connections ⁽¹⁾	ERAA07958A0
36	Pipe Nipple (2 required)	1C2100X0012
37	Pipe Nipple	1N5842X0022
38	Pipe Nipple	1F3948X0012
39	Pipe Nipple	1N5842X0022
40	Pipe Nipple	11A3740X0A2
41	Connector	15A6002XW22
42	Elbow (3 required)	1B8608X0012
43	Elbow (5 required)	15A6002XW32
44	Tubing (2 required)	0500213809W
45	Tubing	0500213809W
48	Lever Assembly	
	Standard	ERAA03023A0
	NH3	
49	Lead Seal and Wire (2 required) (not shown)	T12315T0022
50	Lifting Sling (not shown)	ERAA03264A0

51	Rain Cap (not shown)	ERAA03263A0
52	Lead Seal and Wire (not shown)	1D884799012

Type 63EGLP-16, 2 NPT Mounting Parts (Figure 15)

Key	Description	Part Number
36	Pipe Nipple, (2 required)	1C2100X0012
40	Pipe Nipple	11A3740X0A2
41	Connector	15A6002XW22
43	Elbow, (5 required)	15A6002XW32
44	Tubing, (2 required)	0500213809W
45	Tubing	0500213809W
48	Lever Assembly	
	Standard	ERAA52701A0
	NH3	ERAA58437A0

Type 63EGLP/63EGLP-16

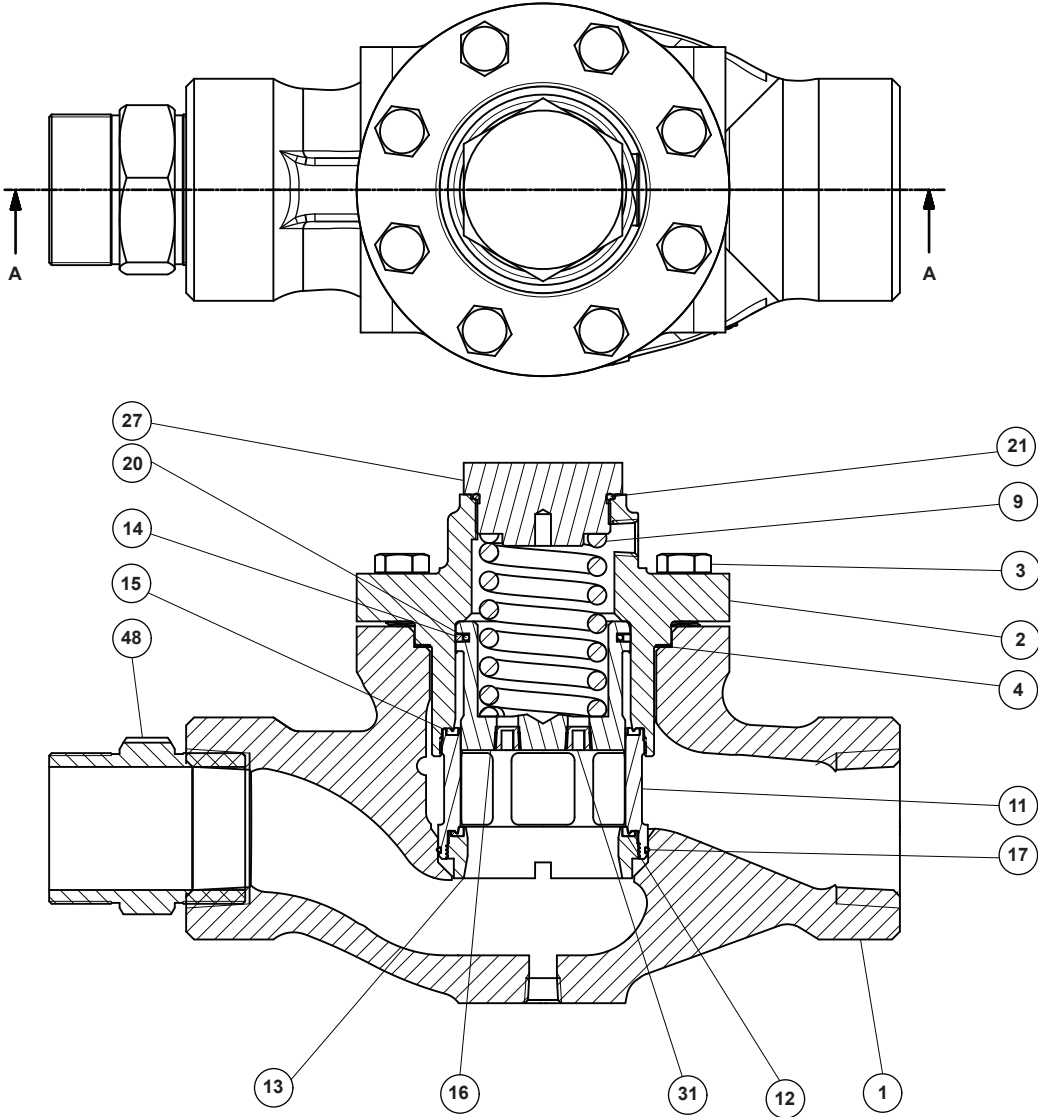
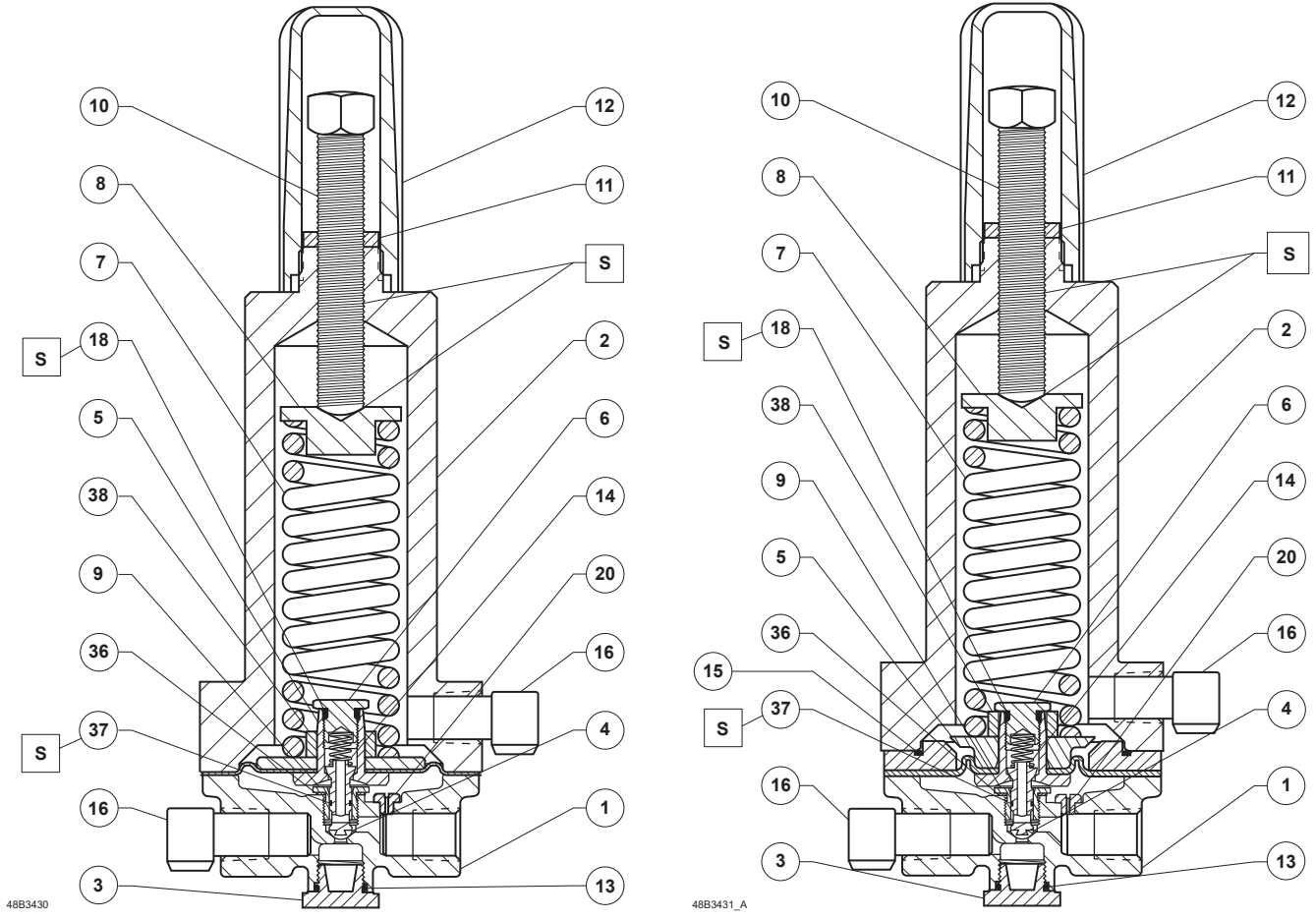
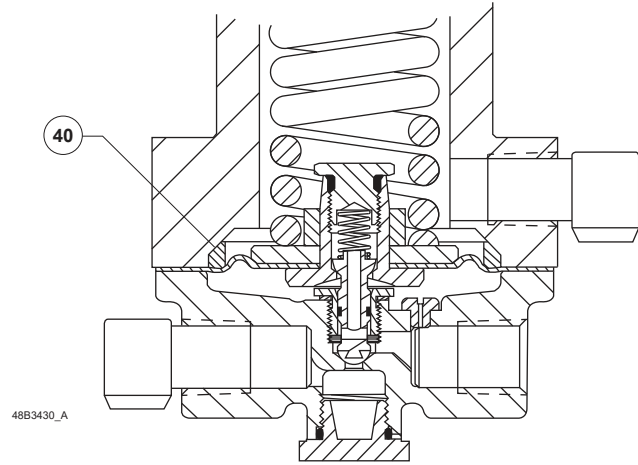

Figure 12. Type 63EGLP-16 Main Valve Assembly for 2 MNPT



TYPE 6358EBLP PILOT INTERIOR VIEW

TYPE 6358EBHLP PILOT INTERIOR VIEW



TYPE 6358EBLP PILOT WITH DIAPHRAGM LIMITER
FOR 180 TO 350 psig / 12.4 TO 24.1 bar
SET PRESSURE RANGE INTERIOR VIEW

□ APPLY SEALANT (S)

Figure 13. Types 6358EBLP and 6358EBHLP Pilot Assemblies

Type 63EGLP/63EGLP-16

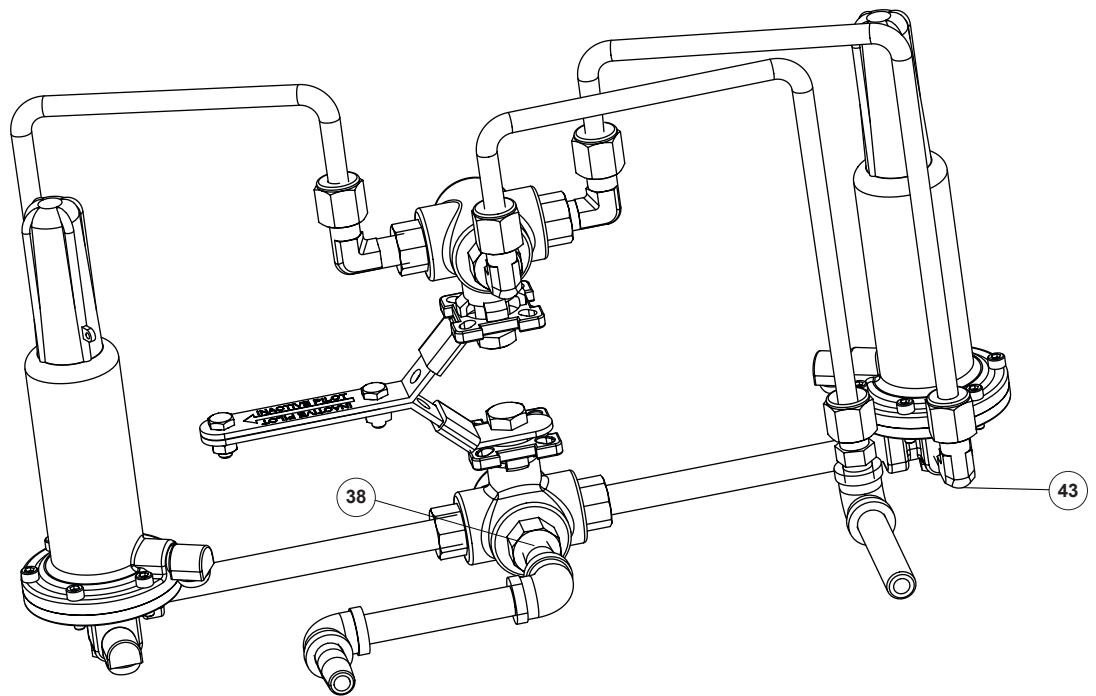
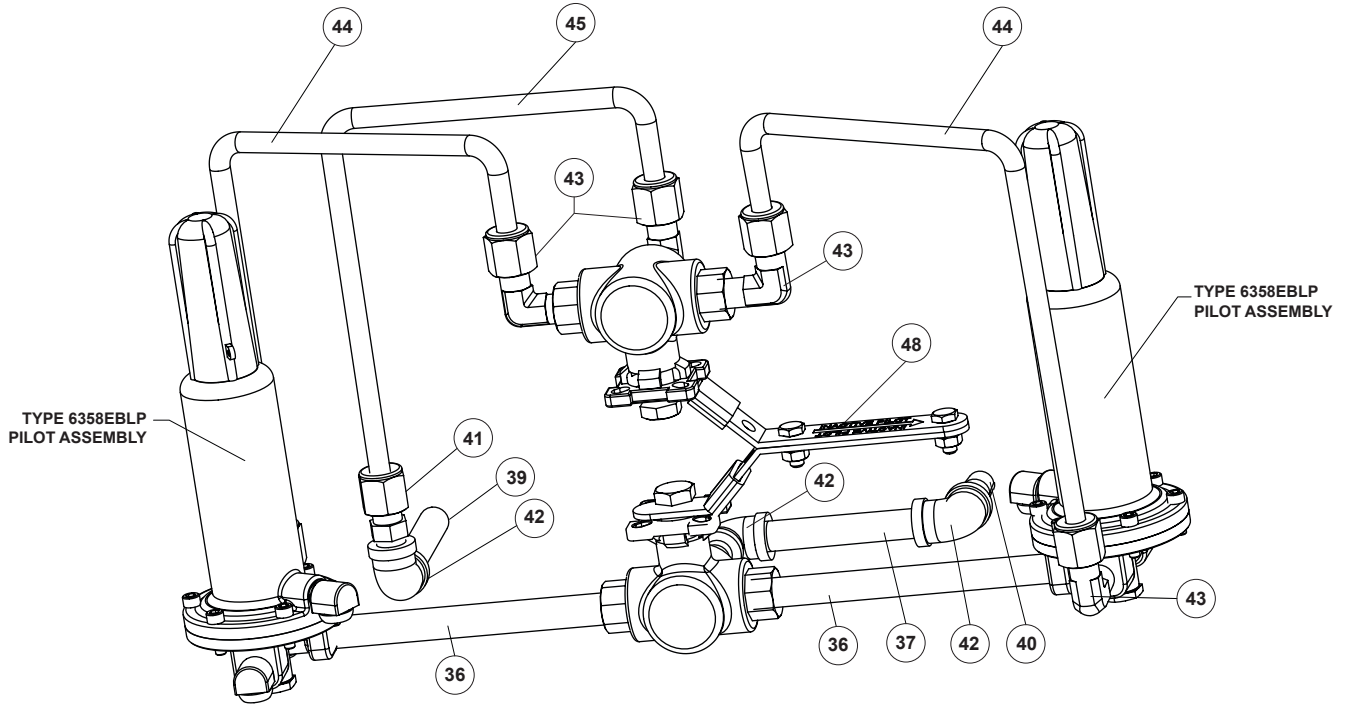

ERAA03024

Figure 14. Mounting Parts Assembly for Type 63EGLP, NPS 4 / DN 100, CL300 RF

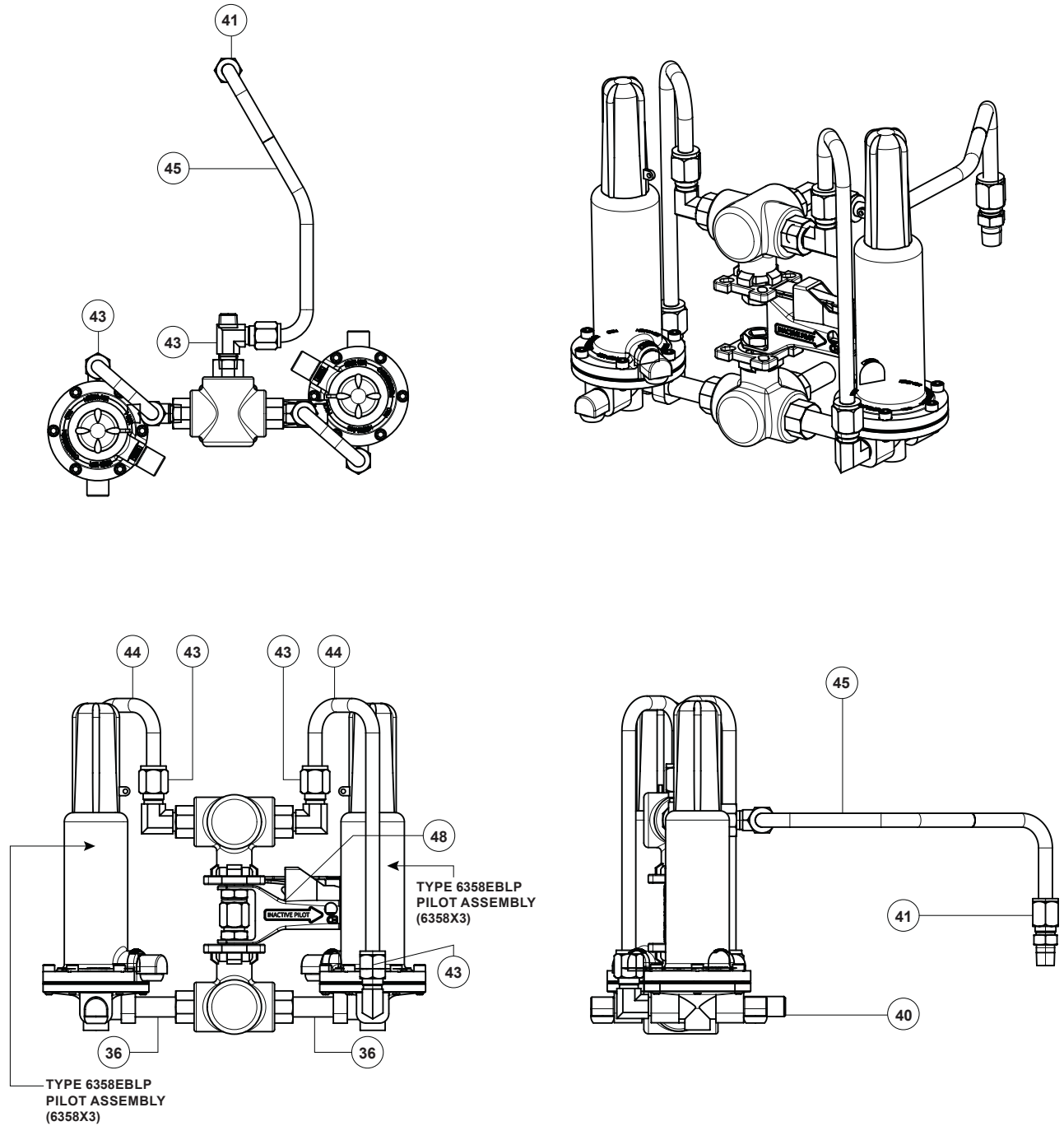

ERAA52569_AA

Figure 15. Type 63EGLP-16 for 2 MNPT

Type 63EGLP/63EGLP-16

✉ Webadmin.Regulators@emerson.com

🔍 Fisher.com

📘 Facebook.com/EmersonAutomationSolutions

🌐 LinkedIn.com/company/emerson-automation-solutions

🐦 Twitter.com/emr_automation

Emerson

Americas

McKinney, Texas 75070 USA
T +1 800 558 5853
+1 972 548 3574

Europe

Bologna 40013, Italy
T +39 051 419 0611

Asia Pacific

Singapore 128461, Singapore
T +65 6777 8211

Middle East and Africa

Dubai, United Arab Emirates
T +971 4 811 8100

D450319T012 © 2013, 2024 Emerson Process Management Regulator Technologies, Inc. All rights reserved. 09/24.

Fisher™ is a mark owned by Fisher Controls International LLC, an Emerson Company. The Emerson logo is a trademark and service mark of Emerson Electric Co. All other marks are property of their respective owners.

The contents of this publication are presented for informational purposes only, and while every effort has been made to ensure their accuracy, they are not to be construed as warranties or guarantees, express or implied, regarding the products or services described herein or their use or applicability. All sales are governed by our terms and conditions, which are available upon request. We reserve the right to modify or improve the designs or specifications of such products at any time without notice.

Emerson Process Management Regulator Technologies, Inc. does not assume responsibility for the selection, use or maintenance of any product. Responsibility for proper selection, use and maintenance of any Emerson Process Management Regulator Technologies, Inc. product remains solely with the purchaser.

