

# Fisher® A41 High Performance Butterfly Valve

## Contents

Introduction .....	1
Scope of Manual .....	1
Description .....	1
Specifications .....	2
Installation .....	3
Valve Orientation .....	5
Maintenance .....	8
Packing Maintenance .....	10
Seal Ring Maintenance for NPS 3 through 12 .....	11
Seal Ring Maintenance for NPS 2 .....	16
Disc, Drive Shaft and Bearing Maintenance for NPS 3 through 12 .....	17
Disc, Drive Shaft and Bearing Maintenance for NPS 2 .....	20
Actuator Mounting .....	21
Parts Ordering .....	23
Retrofit Kits for ENVIRO-SEAL™ Packing ...	23
Repair Kits for ENVIRO-SEAL Packing .....	24
Parts List .....	24

## Introduction

### Scope of Manual

This instruction manual includes installation, maintenance, and parts information for Fisher A41 high performance butterfly valves (figure 1). Refer to separate instruction manuals for information covering the power on-off actuator and accessories.

Do not install, operate, or maintain A41 valves without being fully trained and qualified in valve, actuator, and accessory installation, operation, and maintenance. To avoid personal injury or property



WS269

Figure 1. Fisher A41 Valve

damage, it is important to carefully read, understand, and follow all the contents of this manual, including all safety cautions and warnings. If you have any questions about these instructions, contact your Emerson Process Management sales office before proceeding.

### Description

The A41 high performance butterfly valves have eccentrically mounted discs to reduce wear and reduce torque requirements. The valve includes filled-PTFE or graphite packing rings that electrically bond the shaft to the valve body. This valve has a Double D drive shaft end, and soft or metal seal rings for use in a wide variety of applications.



# A41 Valve

Table 1. Specifications

<p><b>Valve Sizes and End Connection Styles</b></p> <p>NPS ■ 2, ■ 3, ■ 4, ■ 6, ■ 8, ■ 10, and ■ 12 valves in wafer or single flanged style (NPS 2 available in wafer style only)</p> <p><b>Maximum Inlet Pressures<sup>(1)</sup></b></p> <p><b>Carbon Steel, Stainless Steel, and CN7M Valves:</b> Consistent with CL150 and 300 pressure-temperature ratings per ASME B16.34, unless limited by material temperature capabilities. NPS 2 is also consistent with CL600.</p> <p><b>Maximum Pressure Drops<sup>(1)</sup></b></p> <p>Consistent with CL150 and 300 pressure/temperature ratings per ASME B16.34 except for PTFE, UHMWPE, and Phoenix III seals that are derated at some higher pressure/temperatures values. (See figure 2)</p> <p><b>Shutoff Classifications</b></p> <p>■ <b>PTFE, Reinforced PTFE, and UHMWPE<sup>(2)</sup></b>  <b>Seal:</b> No visible leakage for this bidirectional seal per MSS SP-61.</p> <p>■ <b>NPS 2 Metal Seal:</b> Bidirectional shutoff. 0.001% of maximum valve capacity (1/10) of Class IV per ANSI/FCI 70-2 and IEC 60534-4. Pressure Drop is 740 psig forward and 100 psig reverse.</p> <p>■ <b>NOVEX Seal:</b> Unidirectional shutoff is MSS SP-61 in the preferred flow direction.</p> <p>■ <b>Phoenix III Seal:</b> No visible leakage for this bidirectional seal per MSS SP-61. For optional Phoenix III Fire-Tested seal, consult your Emerson Process Management sales office.</p>	<p><b>Flow Characteristic</b></p> <p>Approximately linear</p> <p><b>Flow Direction</b></p> <p>See figure 4</p> <p><b>Disc Rotation</b></p> <p>Clockwise to close (when viewing the drive shaft end) through 90 degrees of disc rotation (see figure 7)</p> <p><b>Valve Classification</b></p> <p>Face-to-face dimensions of NPS 3 through 12 in CL150 or 300, and meets API 609 or MSS-SP68 standards for face-to-face dimensions of wafer-style and single-flange valves</p> <p><b>Actuator/Valve Action</b></p> <p>With the diaphragm or piston actuators, the valve action is field-reversible. Refer to information in the Installation section and in figures 6 and 7.</p> <p><b>Shaft Diameters</b></p> <p>See table 2</p> <p><b>Approximate Weights</b></p> <p>See table 2</p> <p><b>ENVIRO-SEAL Packing</b></p> <p>This optional PTFE or graphite packing system provides excellent sealing, guiding, and transmission of loading force to control liquid and gas emissions (see figure 6). See Bulletin 59.3:041 ENVIRO-SEAL Packing System for Rotary Valves for more information</p>
---	---

1. The pressure/temperature limits in this manual and any applicable standard or code limitation for valve should not be exceeded.  
 2. UHMWPE stands for ultra high molecular weight polyethylene.

Table 2. Valve Size, Shaft Diameter, and Approximate Weight

VALVE SIZE, NPS	CLASS	SHAFT DIAMETER		APPROXIMATE WEIGHT			
				Wafer-Style		Single-Flange	
		mm	Inches	kg	Pounds	kg	Pounds
2	150/300/600	12.7	1/2	4.3	9.5	---	---
3	150	12.7	1/2	4.5	10	6.4	14
	300	15.9	5/8	5.9	13	11	25
4	150	15.9	5/8	8.6	19	11	24
	300	19.1	3/4	10	23	18	39
6	150	19.1	3/4	13	29	16	35
	300	25.4	1	15	33	27	59
8	150	25.4	1	21	47	27	59
	300	31.8	1-1/4	24	53	42	93
10	150	31.8	1-1/4	34	75	40	88
	300	38.1	1-1/2	44	96	78	172
12	150	38.1	1-1/2	49	107	62	137
	300	44.5	1-3/4	64	141	131	288

Table 3. Maximum Allowable Inlet Pressure for M35-1 and CW2M Valve Bodies<sup>(1)</sup>

TEMPERATURE	M35-1			CW2M		
	Bar					
°C						
-46 to 38	15.8	41.3	82.7	20.0	51.7	103.4
93	13.8	36.5	72.7	17.9	51.7	103.4
149	13.1	34.1	68.2	15.9	50.3	100.3
204	12.7	33.1	65.8	13.8	48.6	97.2
260	11.7	32.8	65.5	11.7	45.9	91.7
TEMPERATURE	150	300	600 <sup>(2)</sup>	150	300	600 <sup>(2)</sup>
°F	Psig					
-50 to						
100	230	600	1200	290	750	1,500
200	200	530	1055	260	750	1,500
300	190	495	990	230	730	1,455
400	185	480	955	200	705	1,410
500	170	475	950	170	665	1,330

1. M35-1 and CW2M valve material are not included in ASME B16.34 pressure/temperature ratings. The designations 150 and 300 for this valve material are used only to indicate relative pressure/retaining capabilities and are not ASME pressure/temperature rated classes.  
2. CL600 is only available in NPS 2.

process. Refer to the Actuator Mounting section of this manual and to the separate actuator or handlever instruction manual for mounting and adjustments before proceeding.

**WARNING**

Always wear protective gloves, clothing and eyewear when performing any installation or maintenance operations to avoid personal injury.

To avoid personal injury or property damage resulting from the sudden release of pressure, do not install the valve assembly where service conditions could exceed the limits given in this manual, the limits on the appropriate nameplates, or the matching pipe flange rating. Use pressure-relieving devices as required by government or accepted industry codes and good engineering practices.

Check with your process or safety engineer for any additional measures that must be taken to protect against process media.

If installing into an existing application, also refer to the WARNING at the beginning of the Maintenance section in this instruction manual.

**Installation**

The valve is normally shipped as part of a valve assembly, with the actuator, handlever, or handwheel mounted on the valve. If the valve or actuator have been purchased separately, or if the actuator has been removed for maintenance, mount the actuator on the valve, and adjust actuator travel before inserting the valve body into the line. This is necessary due to the measurements that must be made during the actuator calibration adjustment

# A41 Valve

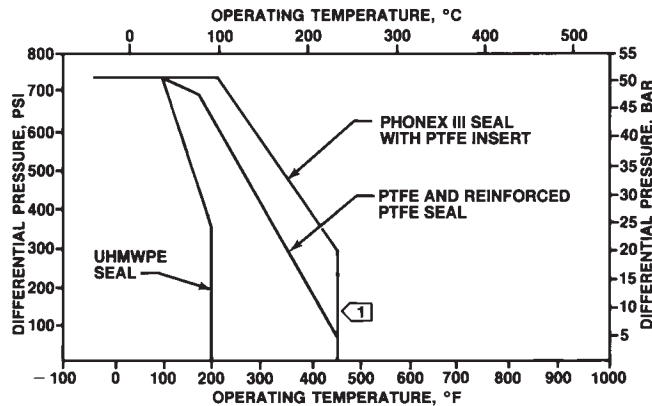

NOTE:  
 (1) TEMPERATURE LIMITATIONS DO NOT ACCOUNT FOR THE ADDITIONAL LIMITATIONS IMPOSED BY THE BACKUP RING USED WITH THIS SEAL. TO DETERMINE THE EFFECTIVE TEMPERATURE LIMITATION OF THE APPROPRIATE SEAL/BACKUP RING COMBINATION, REFER TO TABLE 4.

A6306-2/IL

Figure 2. Maximum Pressure/Temperature Ratings

Table 4. Construction Material Temperature Limits

COMPONENTS AND MATERIALS OF CONSTRUCTION	TEMPERATURE LIMITS	
	°C	°F
<b>Valve Body Material</b>		
Carbon Steel	-29 to 427	-20 to 800
CF8M	-198 to 538	-325 to 1000
CG8M	-198 to 538	-325 to 1000
<b>Disc Material</b>		
316	-198 to 538	-325 to 1000
CG8M	-198 to 538	-325 to 1000
<b>Shaft Material</b>		
S20910	-198 to 538	-325 to 1000
17-4 PH	-62 to 427	-80 to 800
<b>Bearing Material</b>		
PEEK / PTFE lined	-73 to 260	-100 to 500
Metal	-198 to 538	-325 to 1000
<b>Packing Material</b>		
PTFE V-rings	-46 to 232	-50 to 450
Graphite rings	-198 to 438	-325 to 1000
<b>Seal Ring</b>		
PTFE (Standard)	-46 to 232	-50 to 450
Reinforced PTFE Soft Seal Ring	-46 to 232	-50 to 450
UHMWPE Soft Seal Ring	-18 to 93	0 to 200
NOVEX Metal Seal Ring	-46 to 538	-50 to 1000
NPS 2 Metal Seal ring	-46 to 538	-50 to 1000
Phoenix III Metal Seal Ring		
Fluorocarbon backup ring	-40 to 232	-40 to 450
Phoenix III Fire-Tested <sup>(1)</sup> Metal Seal Ring		
Fluorocarbon backup ring (Specify metal bearings and graphite packing)	(1)	(1)

1. For component selection and applicable fire-tested standards and codes, consult your Emerson Process Management sales office.

Hex Head Cap Screw and Stud Bolt Data<sup>(1)</sup>

VALVE SIZE, NPS	WAFER STYLE						SINGLE FLANGE STYLE					
	CL150			CL300			CL150			CL300		
	No. of Stud Bolts	Size Dia Inch & Thread	A Dimension, Inch	No. of Stud Bolts	Size Dia Inch & Thread	A Dimension, Inch	No. of Cap Screws	Size Dia Inch & Thread	B Dimension, Inch	No. of Cap Screws	Size Dia Inch & Thread	B Dimension, Inch
2 <sup>(2)</sup>	4	5/8-11	5	8	5/8-11	5.25	---	---	---	---	---	---
3	4	5/8-11	5.75	8	3/4-10	6.5	8	5/8-11	1.875	16	3/4-10	2
4	8	5/8-11	6	8	3/4-10	7	16	5/8-11	2	16	3/4-10	2.25
6	8	3/4-10	6.5	12	3/4-10	7.5	16	3/4-10	2	24	3/4-10	2.5
8	8	3/4-10	7	12	7/8-9	9	16	3/4-10	2.25	24	7/8-9	3
10	12	7/8-9	8	16	1-8	10	24	7/8-9	2.5	32	1-8	3.5
12	12	7/8-9	8.5	16	1-1/8-8	11	24	7/8-9	2.75	32	1-1/8-8	3.75

1. Thread engagement in accordance with ASME B31.3.  
 2. The NPS 2 valve is only available in wafer style and is multitrated to CL150, 300 and 600. The CL600 stud bolts require 8 bolts, have a dia. of 5/8-11, and are 6- inches long.

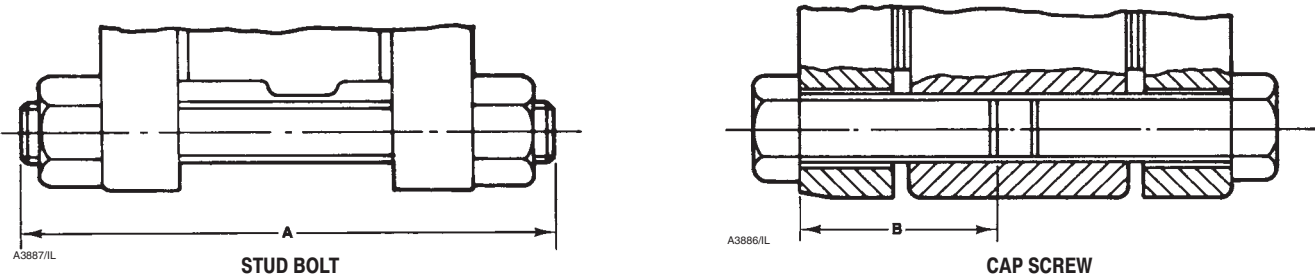

Figure 3. Cap Screws and Stud Bolts for Installation.

**CAUTION**

The valve configuration and construction materials were selected to meet particular pressure, temperature, pressure drop, and controlled fluid conditions specified in the customer’s order. Because some body/trim material combinations are limited in their pressure drop and temperature range capabilities (especially due to differences in thermal expansion rates), do not apply any other conditions to the valve without first contacting your Emerson Process Management sales office.

1. Install a three-valve bypass around the control valve assembly if continuous operation is necessary during inspection and maintenance of the valve.
2. Inspect the valve to be certain that it is free of foreign material.
3. Be certain that adjacent pipelines are free of any foreign material, such as pipe scale or welding slag, that could damage the valve sealing surfaces.

**CAUTION**

Damage to the disc will occur if any pipe flanges or piping connected to the valve interfere with the disc rotation path. If the piping flange has a smaller inner diameter than specified for schedule 80 piping, measure carefully to be certain the disc rotates without interference before putting the valve into operation.

**Valve Orientation**

When installing the valve, it is highly recommended that the valve drive shaft be horizontal as shown in figure 4.

**Valve Direction**

The high performance butterfly valve is designed to allow flow in either direction when in the open position. When in the closed position, high pressure should be applied to a specific side of the disc to provide best performance and optimal valve life (see list of seal types below). See figure 4.

# A41 Valve

Table 5. Special Spiral Wound Gasket Dimensions, Inches

Valve Size, NPS	Class	Gasket Internal Diameter	Gasket Outside Diameter	Centering Outside Diameter <sup>(1)</sup>
3	150	4.25	5.00	5.375
3	300	4.25	5.00	5.875
4	150	5.25	6.125	6.875
4	300	5.25	6.125	7.125

1. Dimension per API 601 and ASME B16.5 Flanges.

Applications with bi-directional seals, such as soft or Phoenix III, under normal operating conditions can (at different times) experience pressure in both directions; the highest of the two pressures should be exerted on the preferred side of the disc. If the two pressures are equal, then the one lasting the longest period of time should be applied to the preferred side.

1. **For PTFE, reinforced PTFE, or UHMWPE seal rings:** This seal is bidirectional. For best performance, high pressure should be applied to the front (retaining ring) side of the disc.

2. **For metal seal rings:**

- a. **NOVEX seal:** The NOVEX seal is uni-directional. High pressure at the closed position **MUST** be at the back (waterway side) of the disc.
- b. **Phoenix III Seal:** This seal is bidirectional. For best performance, high pressure at the closed position should be applied to the back (waterway side) of the disc.
- c. **NPS 2 Seal:** The preferred direction of installation is with high pressure at the front (retaining ring side) of the disc. Reverse shutoff is permissible at lower pressure (see specifications table).

## Installing the Valve in the Pipeline



### WARNING

The edges of a rotating disc have a shearing effect that may result in personal injury. To help prevent such injury, stay clear of the disc edges when rotating the disc (figure 4).

### CAUTION

Damage to the disc (key 3, figure 12) sealing surfaces may occur if the disc is not closed when the valve is being installed or removed from the pipeline. If necessary, provide a loading pressure to the actuator temporarily to retain the disc in the closed position while installing or removing the valve from the pipeline.

1. **For Fail-Open Actuators:** It will be necessary to provide a temporary loading pressure to the actuator diaphragm to move the valve disc to the closed position. Observe the above **Warning** when closing the valve. If a loading pressure is required, use caution when working with the valve. If the loading pressure is disconnected, the disc will open rapidly.
2. With the disc in the closed position, install line flange gaskets, and insert the valve between the pipeline flanges.



### WARNING

If spiral wound gaskets are to be used with an NPS 3 or 4 CL150 or 300 single flange valve, special spiral wound gaskets conforming to the dimensions listed in table 5 **MUST** be used. Improperly sized gaskets may increase the likelihood of 1) excessive seat leakage, 2) damage due to contact with valve internals, and 3) external leakage; which may result in personal injury due to a sudden increase or decrease of pressure within -- or release of pressure from -- the pipeline. The special dimension spiral wound gaskets can be obtained from your local spiral wound gasket vendor.

The remaining single flange valve sizes (NPS 6 through 12) and all wafer style valves (NPS 2 through 12) use the standard size spiral wound gaskets. Only the single flange valves in the sizes and pressures listed in the table above require special spiral wound gaskets.

Select the appropriate gaskets for the application. Flat sheet, spiral wound (NPS 6 through 12), or

other gasket types made to ASME 16.5 group or a user’s standards can be used for A41 valves depending on the service conditions and applications.

3. Install the flange studs:

**Note**

**Lubricate line flange studs or bolts before inserting into flanges. If necessary, provide additional support for the control valve assembly because of its combined weight.**

● **Flange Studs:** Install two or more line flange studs into the line flanges to help hold the valve in position while centering the valve. Carefully center the valve on the flanges to ensure disc clearance.

● Select and install two pipeline gaskets.

● **Flange Cap Screws:** If line flange cap screws are used, be certain the cap screw threads engage the tapped holes to a depth equal to the flange cap screw diameter.

4. Install the remaining line flange bolts to secure the valve in the pipeline. Tighten the bolts in a crisscross pattern to ensure proper alignment of the valve with the flanges.

**Packing Adjustment and Shaft Bonding**

 **WARNING**

Personal injury could result from packing leakage. Valve packing was tightened before shipment; however, the packing might require some readjustment to meet specific service conditions.

**CAUTION**

**Excessive tightening of packing will accelerate wear and could produce higher rotating friction loads on the valve stem.**

1. **For PTFE or graphite packing:** Tighten standard packing follower nuts only enough to

prevent shaft leakage. Excessive tightening of packing will accelerate wear and could produce higher rotating friction loads on the valve stem. If necessary, refer to the Packing Maintenance section.

2. **ENVIRO-SEAL Packing Systems** will not require this initial re-adjustment. Refer to the separate ENVIRO-SEAL Packing System for Rotary Valves Instruction Manual (Form 5305) for repair and adjustment procedures.

3. For hazardous atmosphere or oxygen service valves, read the following **Warning**, and provide the bonding strap assembly mentioned below if the valve is used in an explosive or hazardous atmosphere.

 **WARNING**

**The valve drive shaft is not necessarily grounded to the pipeline when installed. If the process fluid or the atmosphere around the valve is flammable, personal injury or property damage could result from an explosion caused by a discharge of static electricity from the valve components.**

Standard PTFE packing is composed of a partially conductive carbon-filled PTFE female adaptor with PTFE V-ring packing. Standard graphite packing is composed of all conductive graphite ribbon packing rings. Alternate shaft-to-valve body bonding is available for hazardous service areas where you feel the the standard packing is not sufficient to bond the shaft to the valve (see the following steps).

For oxygen service applications it is necessary to provide alternate shaft-to-valve body bonding (see the following steps).

4. Attach the bonding strap assembly (key 131, figure 5) to the shaft with the clamp (key 130, figure 5).

5. Connect the other end of the bonding strap assembly to the valve flange cap screws.

6. For more information, refer to the Packing Maintenance section below.

# A41 Valve

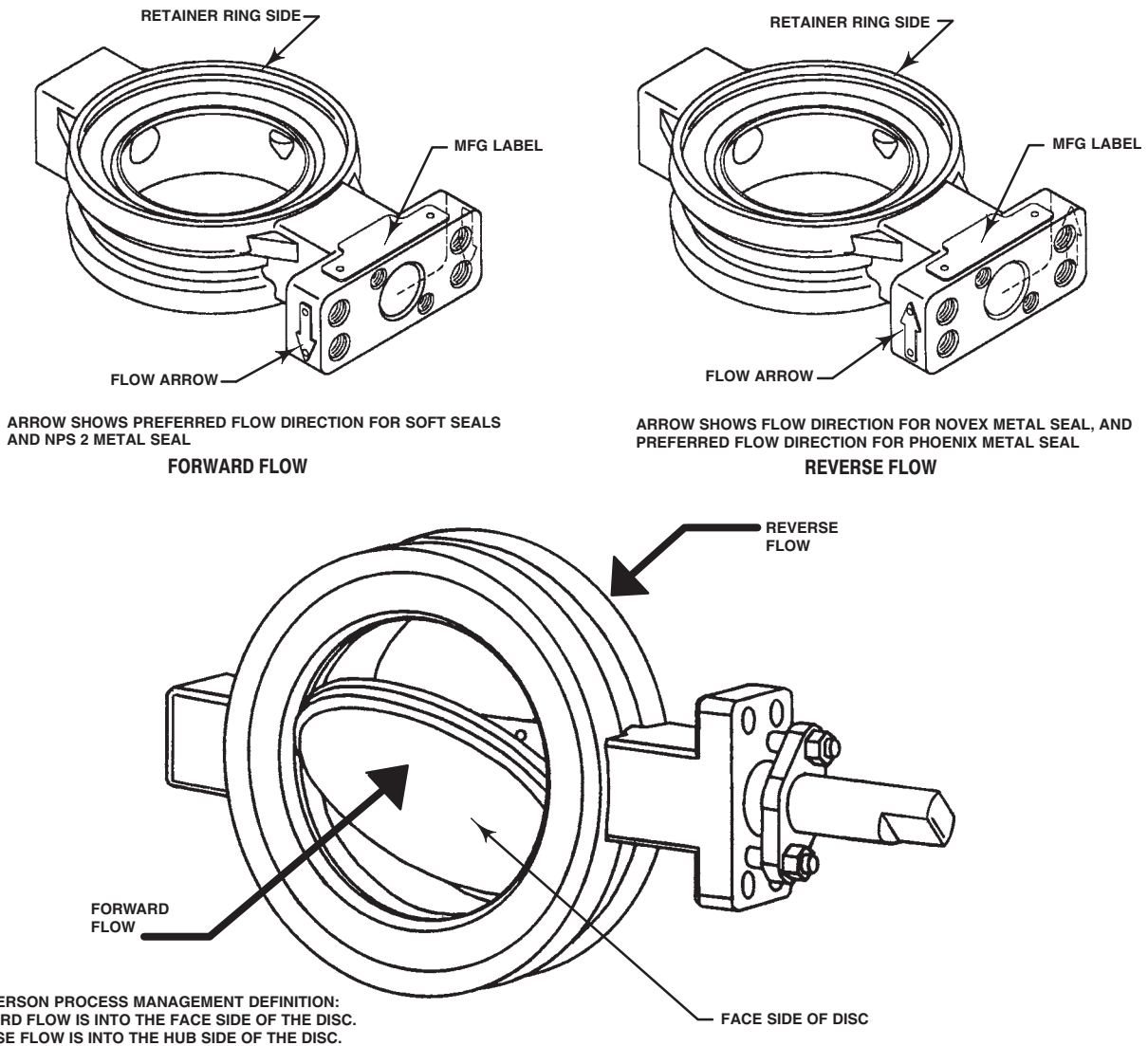

75B1181-A  
 A6881-2/IL

Figure 4. Flow Direction

## Maintenance

Valve parts are subject to normal wear and must be inspected and replaced as necessary. The frequency of inspection and replacement depends upon the severity of service conditions. Instructions are given in this section for replacing packing, seal ring, disc, shaft, bearings, and other valve parts. Also, instructions are provided for changing valve action, mounting, and adjusting the actuator. Refer to the actuator instruction manual for additional information for mounting and adjusting the actuator.

### CAUTION

It is possible to damage the valve if the actuator travel stops are not properly adjusted before stroking the valve.

### WARNING

Avoid personal injury or property damage from sudden release of

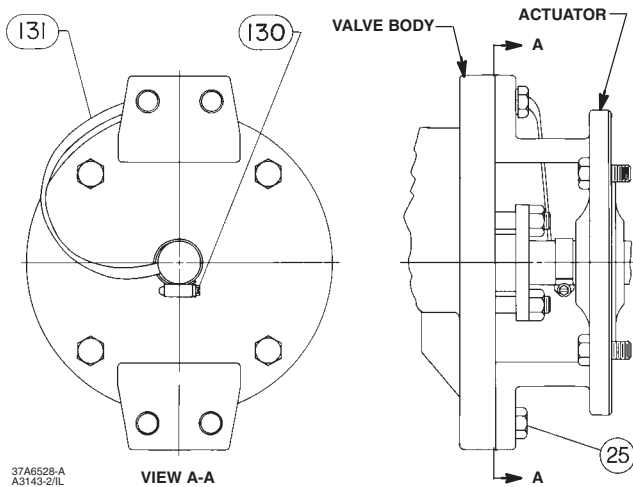

37A6528-A  
A3143-2/IL

Figure 5. Optional Shaft-to-Valve Body Bonding Strap Assembly

process pressure or bursting of parts. Before performing any maintenance operations:

- Do not remove the actuator from the valve while the valve is still pressurized.
- Always wear protective gloves, clothing, and eyewear when performing any maintenance operations to avoid personal injury.
- Disconnect any operating lines providing air pressure, electric power, or a control signal to the actuator. Be sure the actuator cannot suddenly open or close the valve.
- Use bypass valves or completely shut off the process to isolate the valve from process pressure. Relieve process pressure from both sides of the valve. Drain the process media from both sides of the valve.
- Vent the pneumatic actuator loading pressure and relieve any actuator spring precompression.
- Use lock-out procedures to be sure that the above measures stay in effect while you work on the equipment.
- The valve packing box may contain process fluids that are

pressurized, even when the valve has been removed from the pipeline. Process fluids may spray out under pressure when removing the packing hardware or packing rings, or when loosening the packing box pipe.

- Check with your process or safety engineer for any additional measures that must be taken to protect against process media.

**WARNING**

The edges of a rotating disc have a shearing effect that may result in personal injury. To help prevent such injury, stay clear of the disc edges when rotating the disc (key 3).

**CAUTION**

During the following steps, do not rotate the disc past 90 degrees in the open direction. Rotating the disc past 90 degrees can damage the seal ring.

Use caution when tightening the packing flange nuts. Overtightened nuts can damage packing box parts.

**Stopping Leakage**

For PTFE-filled or graphite standard packing arrangements covered in this manual, often leakage from the packing can be stopped by tightening the packing flange nuts just enough to stop the leak. Use caution when tightening the nuts, overtightened nuts can damage packing box parts.

- If tightening the packing flange nuts does not stop the leakage, use the following procedures to remove the control valve assembly from the pipeline, remove the actuator, and to remove and replace the packing parts.
- If the leakage comes from the outside diameter of the packing box, it is possible that the leakage is caused by scratches on the packing box wall. Carefully inspect the packing box bore and valve drive shaft when the packing is removed. Use the following steps to remove the actuator, and to remove and replace the packing parts.

# A41 Valve

## Removing the Actuator

### WARNING

Refer to the **WARNING** at the beginning of the Maintenance section in this instruction manual.

1. Isolate the control valve from the line pressure, release pressure from both sides of the valve body, and drain the process media from both sides of the valve. If using a power actuator, also shut off all pressure lines to the power actuator, and release all pressure from the actuator. Use lock-out procedures to be sure that the above measures stay in effect while you work on the equipment.

### WARNING

The edges of a rotating disc have a shearing effect that may result in personal injury. To help prevent such injury, stay clear of the disc edges when rotating the disc (figure 4).

### CAUTION

Damage to the disc (key 3) sealing surfaces may occur if the disc is not closed when the valve is being removed from the pipeline. For fail open actuators, it may be necessary to apply loading pressure to the actuator to retain the disc in the closed position while removing the valve from the pipeline.

2. Be sure the disc is in the closed position before attempting to remove the valve from the pipeline or flanges.

**For Fail-Open Actuators:** It will be necessary to provide a temporary loading pressure to the actuator to move the valve disc to the closed position. Observe the above **Warning** when closing the valve. If a loading pressure is required, use caution when working with the valve. If the loading pressure is disconnected, the disc will open rapidly.

3. With the disc in the closed position, remove line bolting. Remove the valve assembly from the pipeline, and place the actuator/valve assembly on a flat working surface.

4. If a grounding strap is used (see figure 5), remove the hex nut to release the end of the strap. Remove the clamp (key 130) and strap (key 131).

5. Note the orientation of the actuator with respect to the valve body. Also, remove the actuator cover to note the orientation of the actuator with respect to the valve drive shaft (see figure 7).

When re-assembling the valve assembly, you will need to correctly position the mark on the end of the valve drive shaft and the valve body, with respect to the actuator drive shaft. Refer to the Actuator Mounting section and figure 7 for the location of the mark on the actuator end of the valve drive shaft. Additional information is provided in the actuator manual to assist with disassembly, re-assembly, and travel adjustments.

6. Remove the actuator mounting screws (key 14).

7. Remove the actuator from the valve, and remove the valve/actuator coupling.

## Packing Maintenance

### WARNING

Refer to the **WARNING** at the beginning of the Maintenance section in this instruction manual.

Standard graphite packing is composed of all conductive packing rings. PTFE-filled packing has a partially conductive packing ring (such as a carbon-filled PTFE female adaptor) to electrically bond the shaft to the valve body.

If the valve is equipped with the optional ENVIRO-SEAL Packing System, refer to the separate ENVIRO-SEAL Packing System for Rotary Valves Instruction Manual (Form 5305) for packing maintenance procedures.

When replacing the packing, it is recommended that you remove the control valve assembly from the pipeline. Valve/actuator travel adjustments must be made with the valve out of the pipeline.

### Disassembly

Part locations and key numbers are shown in figures 5 and 11.

1. Remove the packing flange nuts (key 101) and the packing flange (key 114).

2. Remove the old packing rings, using a formed hook.

**CAUTION**

**Carefully use the hook. Avoid scratching the drive shaft or packing box wall. Scratches on valve surfaces can cause leakage. [Note: the packing box ring (key 107) can remain in place when replacing the packing only.]**

Clean all accessible metal parts and surfaces to remove particles that would prevent the packing from sealing.

**Assembly**

Inspect the shaft. If it is damaged, it cannot make a good seal with the packing and it must be replaced. If the leakage comes from the outside diameter of the packing, it is possible that the leakage is caused by nicks or scratches around the packing box wall. Inspect the packing box wall for nicks and scratches when performing the following procedures.

If the valve is equipped with the ENVIRO-SEAL packing system, refer to the separate ENVIRO-SEAL Packing System for Rotary Valves Instruction Manual (Form 5305) for assembly.

**Note**

**Except with oxygen service, lightly lubricate new PTFE V-rings with silicone-base lubricant to aid in assembly.**



**WARNING**

**Do not lubricate parts when used in oxygen service, or where the lubrication is incompatible with the process media. Any use of lubricant can lead to the sudden explosion of media due to the oil/oxygen mixture, causing personal injury or property damage.**

1. Install the new packing parts (see figure 6). Install the packing follower and finger tighten the packing flange nuts onto the studs only enough to stop leakage.
2. If the valve was equipped with a bonding strap assembly (figure 5), re-install the assembly.

3. Refer to the Actuator Mounting section of this manual. If necessary, refer to the separate actuator instruction manual for adjustment procedures.

4. When the valve is being placed into operation, check around the packing follower for leakage.

For PTFE-filled or graphite standard packing arrangements covered in this manual, often leakage from the packing can be stopped by tightening the packing flange nuts just enough to stop the leak.

**CAUTION**

**Use caution when tightening the nuts, overtightening nuts can damage packing box parts and result in increased drive shaft friction.**

**Seal Ring Maintenance for NPS 3 through 12**

Perform this procedure if the control valve is not shutting off properly (that is, if it is leaking downstream). It is recommended, but not required, to remove the actuator for easier handling of the valve during the following procedures.

Key numbers are shown in figure 12 unless otherwise noted.

**CAUTION**

**During any of the following steps, do not rotate the disc past 90 degrees in the open direction. Rotating the disc past 90 degrees can damage the seal ring.**

**Disassembly**

Refer to removing the actuator steps in the Packing Maintenance section. Most maintenance procedures will require the actuator to be removed.

1. Removing the retainer ring (key 2):

**For valves with press-fit retainer rings:**

- Place the valve on blocks with the seal retainer facing *down*. (Note: Position blocks so they do not restrict the retainer ring removal.)
- Rotate the disc to the open position as shown in figure 7.
- On the seal ring side of the retainer ring, locate one of the knock-out points machined on the retainer

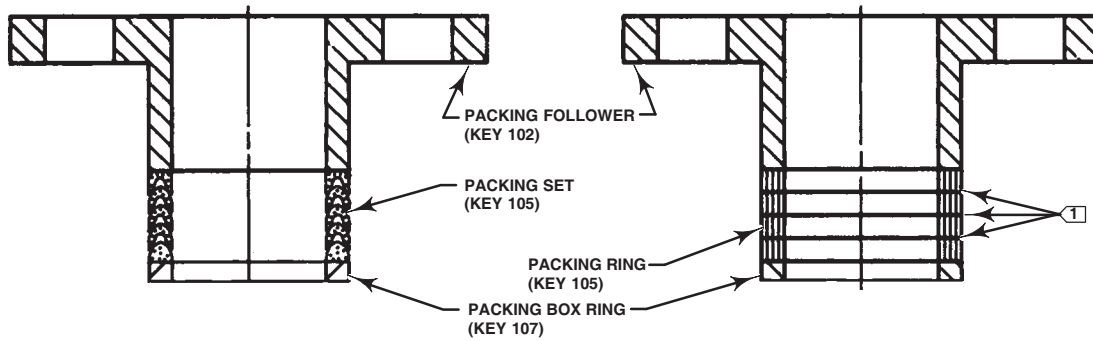

PTFE V-RING PACKING

GRAPHITE RIBBON PACKING

STANDARD PACKING

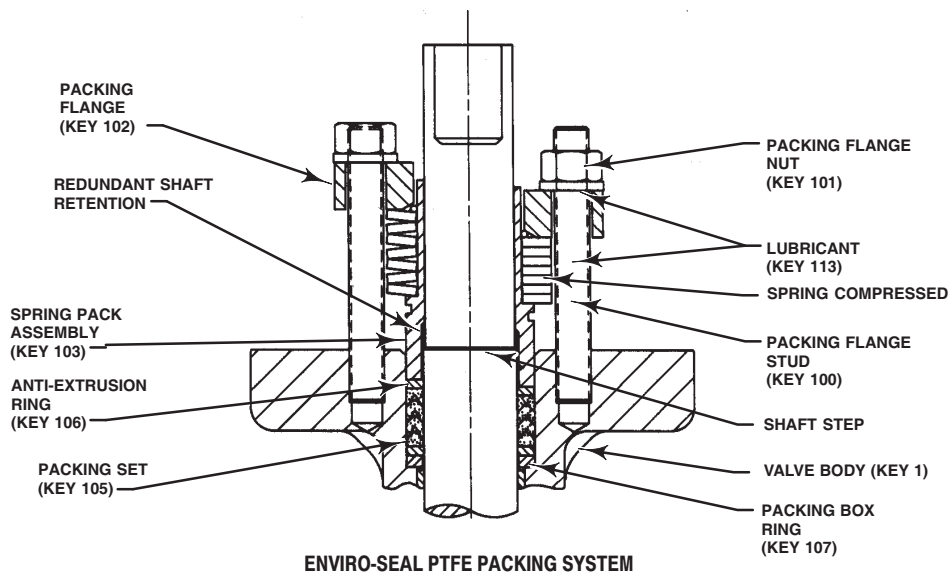

ENVIRO-SEAL PTFE PACKING SYSTEM

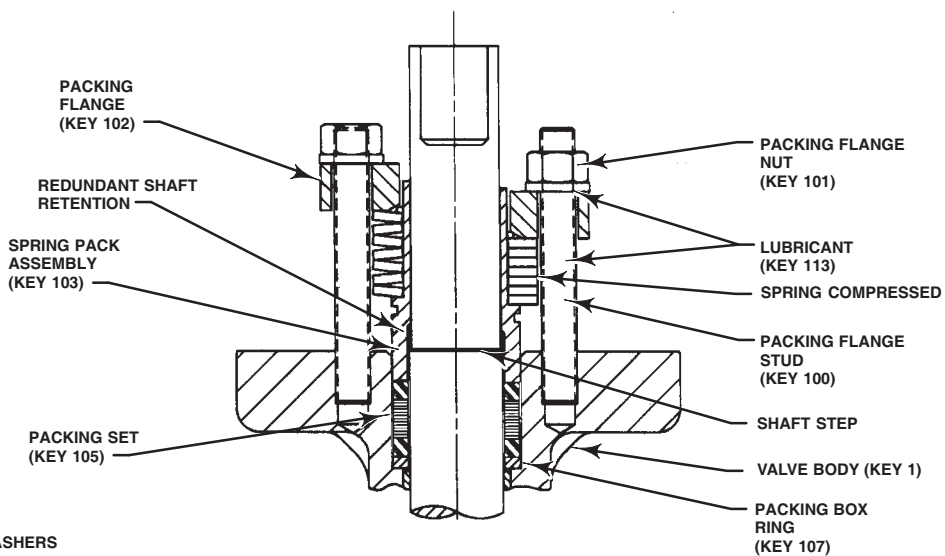

ENVIRO-SEAL GRAPHITE PACKING SYSTEM

NOTE:  
 1 INCLUDES ZINC WASHERS  
 FOR GRAPHITE RIBBON PACKING ONLY

11B5895-A  
 10B6817-A  
 B2435  
 C0785-2

Figure 6. Typical Packing Arrangements

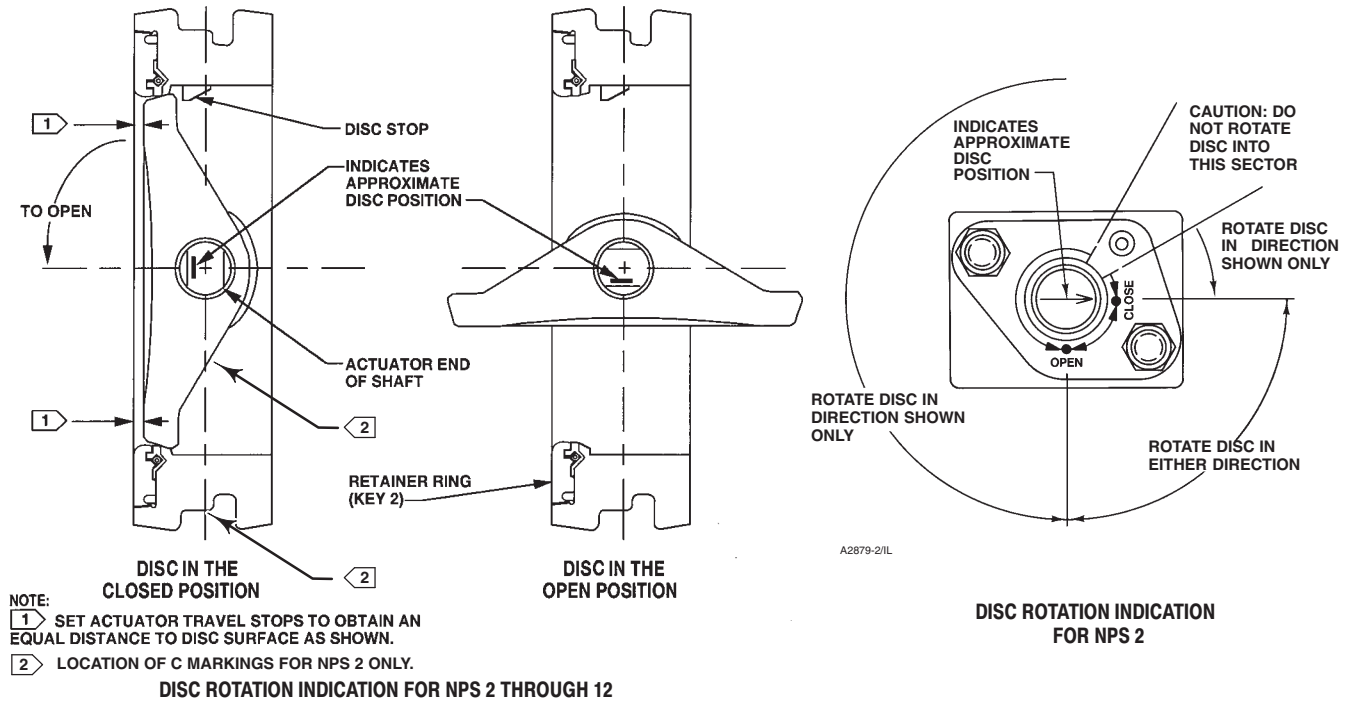

Figure 7. Disc Rotation Indication

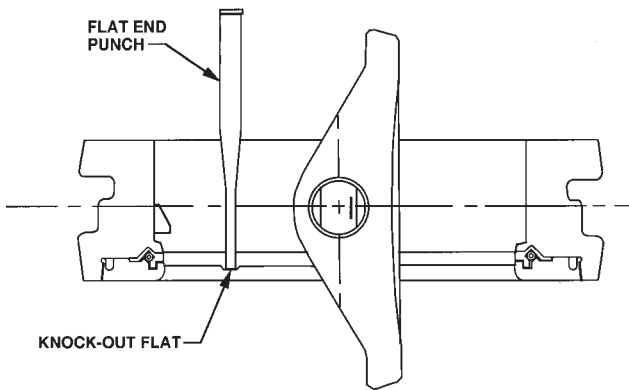

Figure 8. Removing the Retainer Ring

ring. Using a hammer and flat end punch on the knock-out point, pop-out the retainer ring from the valve body (see figure 8).

**CAUTION**

When popping out the retainer ring, be very careful to hit only the knock-out points. Hitting anywhere else can cause non-repairable damage to the t-slot area.

- For valves with PTFE seal rings, remove the spring (key 5) as it may be necessary to re-install the spring into the new PTFE seal ring.

- Clean all sealing surfaces and parts before re-assembly. Proceed to step 3 below.

**For valves with screwed retainer rings:**

- Place the valve on blocks with the seal retainer facing up.

- Remove the retainer ring screws (key 23). If necessary, use two of the retainer screws, in the tapped holes in the retainer ring (key 2) to jack the retainer ring loose from the valve body surface.

2. Remove the seal ring from the valve body seal ring slot.

- For valves with PTFE seal rings, remove the spring (key 5) as it may be necessary to re-install the spring into the new PTFE seal ring.

- For valves with metal seals, remove the gasket (key 16) from the valve body surface, and discard it as replacement is recommended.

3. If it is necessary to replace the disc, drive shaft, and the bearings, refer to the Disc, Drive Shaft, and Bearing Maintenance section before proceeding with

# A41 Valve

the assembly procedures for the seal ring and retainer. The seal ring could be damaged if it is in place while removing the disc.

## CAUTION

**Follow instructions in this manual to avoid damage to the seal ring while either removing or installing the disc.**

### Assembly

Place the valve on blocks with the seal retainer facing up. If the replacement disc, shaft, and bearings have not been installed in the valve body, go to the Assembly procedures to install them. Do not install the seal ring without the disc being in place. The seal ring could be damaged while installing the disc.



## WARNING

**Do not lubricate parts when used in oxygen service, or where the lubrication is incompatible with the process media. Any use of lubricant can lead to the sudden explosion of media due to the oil/oxygen mixture, causing personal injury or property damage.**

## CAUTION

**Do not rotate the disc past 90 degrees in the open direction. Rotating the disc past 90 degrees can damage the seal ring or other component parts.**

### Note

PTFE, NOVEX, and Phoenix III seal rings used in other valve types are not interchangeable with seal rings used in the A41 valve. The A41 seal rings are not interchangeable with seal rings in any other valve type. To order seal rings for this valve, provide the serial number on the valve.

### 1. Installing PTFE seal rings:

a. The valve disc should be open while installing the seal ring. If not, rotate the disc to the open position as shown in figure 7.

b. Hook the spring ends together, insert the spring (see figure 9) into the groove in the seal ring, and work the spring into the recess in the PTFE seal ring.

c. Install the seal ring (key 4) assembly into the slot in the valve body as shown in figure 9. Refer to installing the retainer ring steps below.

### 2. Installing metal seals:

#### Note

**For metal seals only, it may be necessary to apply dry film lubricant or equivalent moly disulfide to the sealing surfaces of the disc, seal, and the seal retainer groove. Prior to applying the lubricant, the sealing surfaces should be inspected for injurious defects. Surfaces can be polished using a scouring pad or equivalent. The edge of the seal that contacts the retaining ring groove should also be inspected and polished if necessary.**

a. Rotate the disc to the open position as shown in figure 7. The seal ring will be damaged if the disc remains in the closed position during seal and retainer ring assembly.



## WARNING

**Do not lubricate parts when used in oxygen service, or where the lubrication is incompatible with the process media. Any use of lubricant can lead to the sudden explosion of media due to the oil/oxygen mixture, causing personal injury or property damage.**

b. Install the metal seal ring assembly (see figure 9).

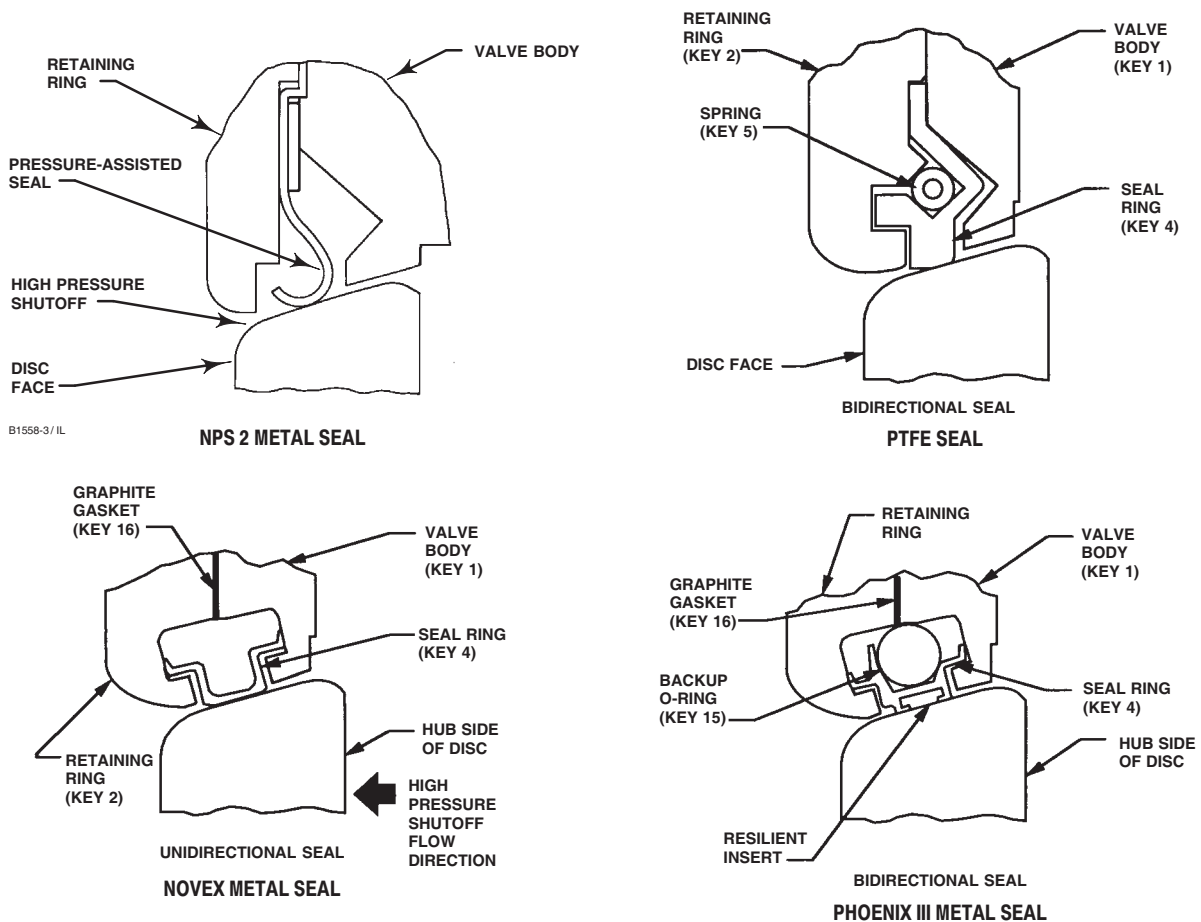

Figure 9. Available Seal Configuration

3. Installing the retainer ring:

- a. Valves with PTFE seal rings do not require a retainer ring gasket (key 16).
- b. Valves with metal seals require a retainer ring gasket (key 16). The gasket is not pre-punched for insertion of retainer screws. The holes are not necessary for press-fit retainer rings.

4. For valves with press-fit retainer rings

- a. Wipe excessive oil off the retainer ring outside diameter, and off the retainer counterbore in the valve body.
- b. Rotate the disc to the open position.
- c. Lay the retainer ring on the valve body.
- d. Use a press or a soft-faced hammer to press the retainer ring into its groove in the valve body.

**CAUTION**

When handling the new retainer ring gasket, be sure to avoid kinking, cracking, or breaking the gasket. Damage to the gasket can cause leakage between the seal retainer and valve body.

- c. Lay the gasket (key 16) down so that it is accurately centered on the valve body.

**CAUTION**

It takes a considerable amount of force with a hammer to drive the retainer ring into place. Be sure not to damage retainer ring surfaces when installing the ring.

# A41 Valve

e. The retainer ring is properly seated when the face of the retainer ring is flush with the face of the valve body.

f. To ensure proper seal performance for metal seals, you may need to use the hammer to drive the disc open for the first few times. When closing the valve, use the C clamps discussed in the next few steps.

## CAUTION

**Do not damage the gasket seating surfaces on either the valve body or the retainer ring when installing or removing the C-clamps. Protect the gasket surface by using a soft material between the clamp and valve body/retaining ring serrations to avoid damage.**

g. Use three C-clamps to hold the retainer in place. Locate one of the C-clamps near the travel stop in the valve body, and the other two at 120 degrees from the stop.

h. When cycling the disc for the first three times, use a dead-blow hammer, with a soft head to drive the disc closed. Also, you may need to use the hammer to drive the disc open for the first few times.

### 5. For valves with screwed retainer rings

a. Match the retainer ring with the holes in the valve by punching two holes in the gasket to locate where the screw holes are in the valve.

b. Lay the retainer ring over the gasket, while lining it up with the punched holes. Also insert two retainer screws (key 17). Finger tighten them.

c. Press the remaining screws through the gasket material and finger tighten them. When all retainer screws are in place, tighten them in a crisscross pattern.

d. The retainer ring is properly seated when the retainer face is flush with the face of the valve.

6. Turn the disc into and out of the seal ring several times, to help break in the seal and reduce actuator torque requirements during adjustment.

7. If replacing the packing, remove all packing parts from the valve body. Upon re-assembly of the valve,

refer to the Packing Maintenance procedures to replace the packing.

### **Seal Ring Maintenance for NPS 2**

This procedure is to be performed if the control valve is not shutting off properly (that is, leaking downstream). This procedure does not require removing the actuator from the valve body. Part key numbers are shown in figure 12.

## WARNING

**Refer to the WARNING at the beginning of the Maintenance section in this instruction manual.**

1. Isolate the control valve from line pressure, and relieve pressure from the valve body. Shut off and disconnect all lines from the power actuator.

## WARNING

**The edges of a rotating disc have a shearing effect that may result in personal injury. To help prevent such injury, stay clear of the disc edges when rotating the disc (key 3).**

## CAUTION

**Damage to the disc (key 3) may occur if the disc is not closed when the valve is being removed from the pipeline. If necessary, pressure the actuator temporarily to retain the disc in the closed position while removing the valve from the pipeline.**

2. Unscrew the flange bolts, and remove the valve from the pipeline.

3. Unscrew the machine screws (key 8), and remove the seal retainer (key 2). Also remove the retainer clip (key 34).

4. Remove the seal ring or seal ring assembly (key 4). The spring (key 5) is removed with a PTFE seal ring.

5. **For 316 stainless steel seal ring assemblies**, replace the gaskets (key 4C) if the entire seal ring assembly is not replaced. Scrape off the old gaskets from both sides of the seal ring and the seal ring sides of the valve body (key 1) and seal retainer. Clean the gasket surfaces.

6. Reconnect or mount the actuator (if it was removed) before proceeding.

For an actuator with adjustable travel, also adjust the actuator before proceeding. This is necessary due to the measurements that must be made during the actuator adjustment process.

Refer to the Actuator Mounting section of this manual and to the separate actuator instruction manual for mounting and adjusting instructions.

7. The valve should be closed during seal ring installation to permit accurate centering of the seal. To install the new seal ring:

**For a PTFE seal**, if the spring (key 5) was disassembled, hook the spring ends together. Work the spring into the recess in the seal ring (key 4). Install the seal ring and spring assembly into the recess in the valve body as shown in figure 13.

**For a complete 316 stainless steel seal ring assembly**, install the seal ring assembly as shown in figure 13.

8. **For a 316 stainless steel seal ring** on which the gaskets will be replaced, lay the following parts down in order so that they are accurately centered on the valve: one new gasket; the seal ring oriented as shown in figure 13; and the second new gasket.

9. Attach the seal retainer and, if used, the retainer clips and washers to the valve body and secure with the machine screws. Tighten the machine screws evenly so as not to crack or break the 316 stainless steel seal ring gaskets, if used.

Be certain the disc is closed before installing the valve according to the Installation section of this instruction manual.

### ***Disc, Drive Shaft, and Bearing Maintenance for NPS 3 through 12***

This procedure is to be performed when replacing the valve disc, drive shaft, taper pins, hollow pins, and bearings due to wear or damage to one or more component parts.

Part locations and key numbers are shown in figures 9 and 11 unless otherwise noted.

#### **Disassembly**

1. If necessary, loosen the packing flange nuts (key 101). This allows the drive shaft (key 8) to turn without the friction caused by the packing.

2. Remove the actuator, using the steps provided in the packing maintenance procedures above, and remove the seal ring using the steps provided in the seal ring maintenance procedures above.

3. Place the valve on a flat working surface with the seal ring slot facing *down*.

4. Use blocks to raise the valve body high enough to allow the disc to be rotated to the fully open position (figure 7).

5. Rotate the disc (key 3) to the fully open position.

6. Locate the small ends of the taper pins. Drive the two taper pins (key 10) out towards the larger end of pins. (Note: Attempting to drive the taper pins in the opposite direction only tightens the pins.) Also, remove the hollow pins (key 9) from the disc/shaft connection using the tool shown in figure 11.

#### **Note**

**Make the tools for removing and installing the hollow pin shown in figure 11.**

7. Unscrew and remove the packing flange nuts (key 101), and the packing flange (key 102).

### **WARNING**

**Once the shaft has been removed in the following step, the disc may fall out of the valve body cavity. To avoid personal injury and damage to disc sealing surfaces, support the disc to prevent it from falling as the shaft is being removed.**

8. Pull the shaft out of the valve body, and remove the disc (key 3) from the valve body bore.

9. If the packing is to be replaced, remove all packing parts from the valve body. Upon re-assembly of the valve, refer to the Packing Maintenance procedures to replace the packing.

10. Remove both of the bearings (key 6) from the valve body. For CL150 valves with metal bearings, refer to the following note.

# A41 Valve

## Note

CL150 valves with metal bearing assemblies have three parts. A disc spacer, bearing, and bearing spacer (keys 7, 6, and 13) are used in place of a single piece bearing. The disc spacers may fall out of the valve when the disc is removed. If needed for re-assembly, retain the disc spacer and bearing spacer parts.

11. Clean all of the sealing surfaces and parts, and inspect and/or replace before assembly.

## Assembly

1. Install the bearings (key 6):

When installing the bearings in the opposite side of the valve body bore, repeat the following procedure.

- **For PEEK/PTFE CL150 and CL300 metal bearings, one piece bearings:** Position the bearing edge to match the valve body bore, and insert the one piece bearing/disc spacer into the bearing bore with the bearing/spacer tab facing away from the disc stop as shown in figure 10.

- **For CL150 metal bearings, three piece assemblies:** Metal bearings for CL150 valves are an

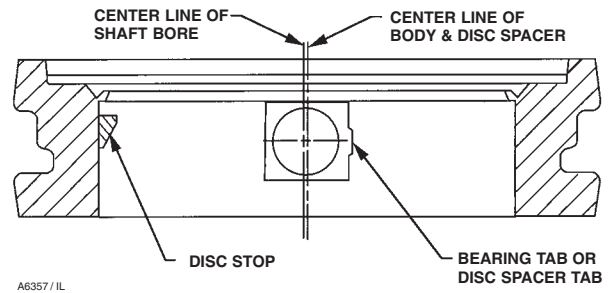

Figure 10. Orientation of Bearing/Spacer Tab

assembly made up of three parts: disc spacer, bearing, and bearing spacer (keys 13, 6, and 7) as shown in the orientation of bearing/spacer tab shown in figure 10.

- Install the bearing spacer (key 13) into the bearing bore.
- Install the bearing into the bearing bore until the bearing is flush with the valve body bore.
- When installing the disc spacer (key 7) position the curved side to match the valve body bore, and position it with the tab on the spacer pointing away from the disc stop as shown in figure 10.

REMOVAL TOOL DIMENSIONS				
Shaft Diameter	ØA	B	C	ØD
mm				
12.7	3.91	28.43	6.35	4.19
15.88	4.60	38.10	7.87	23.37
19.05	5.13	44.45	9.65	5.41
25.4	7.00	59.44	12.70	7.26
31.75	9.50	76.20	19.05	9.78
38.1	10.82	88.90	19.05	11.10
44.45	12.37	114.30	22.35	12.65
Inch				
0.5	0.154	1.12	0.25	0.165
0.625	0.181	1.50	0.31	0.192
0.75	0.202	1.75	0.36	0.213
1	0.275	2.34	0.50	0.286
1.25	0.374	3.00	0.75	0.385
1.5	0.426	3.50	0.75	0.437
1.75	0.487	4.50	0.88	0.498

INSTALLATION TOOL DIMENSIONS					
Shaft Diameter	ØA	ØB	ØC	D	E
mm					
12.7	12.7	3.68	6.35	127.0	4.83
15.88	12.7	4.57	7.62	127.0	4.83
19.05	12.7	5.23	8.89	127.0	4.83
25.4	12.7	7.00	10.41	127.0	4.83
31.75	19.05	10.00	13.59	146.0	6.35
38.1	19.05	11.56	15.24	146.0	6.35
44.45	19.05	31.21	16.76	146.0	6.35
Inch					
0.5	0.50	0.145	0.250	5.00	0.19
0.625	0.50	0.180	0.300	5.00	0.19
0.75	0.50	0.206	0.350	5.00	0.19
1	0.50	0.275	0.410	5.00	0.19
1.25	0.75	0.395	0.535	5.75	0.25
1.5	0.75	0.455	0.600	5.75	0.25
1.75	0.75	0.520	0.660	5.75	0.25

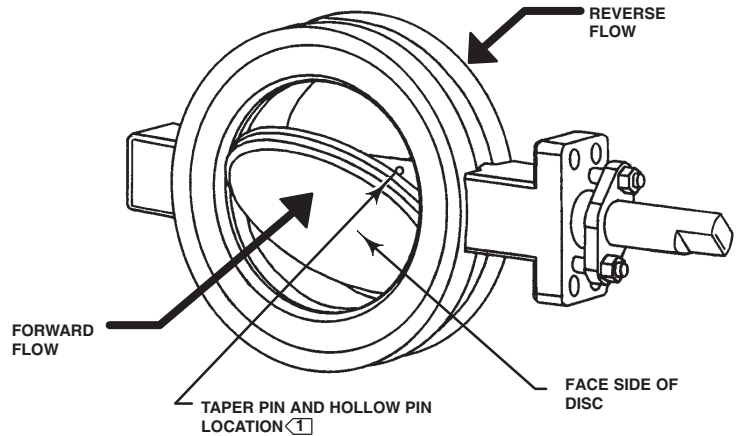
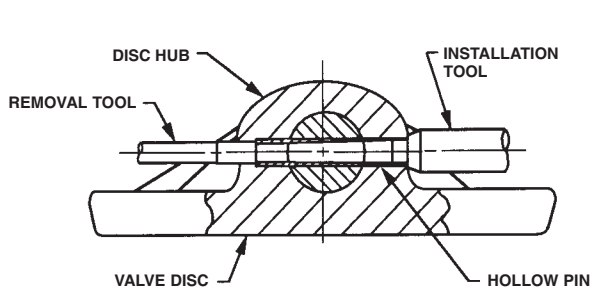
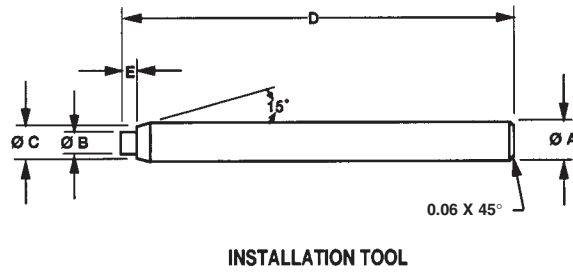
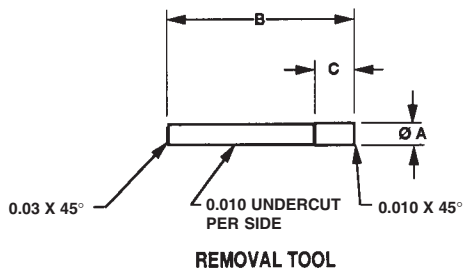

**NOTE:**  
 (1) REMOVE THE HOLLOW PIN FROM THIS SIDE OF THE DISC HUB.  
 INSTALL THE HOLLOW PIN FROM THE OPPOSITE SIDE OF DISC HUB.

A6356 / L

Figure 11. Taper Pin and Hollow Pin Removal and Installation

# A41 Valve

## Note

**The disc spacer will have to be held in place when installing the disc and inserting the shaft through the valve body, bearings, bearing spacer, and disc. To help hold the spacer in place, apply lubricant.**

2. Position the disc to be certain that the holes in the disc are towards the actuator side of the valve. Carefully insert the disc into the valve body bore while protecting the disc sealing surfaces.
3. Install the shaft (key 8):
  - **For PEEK/PTFE CL150 and CL300 metal bearings, one piece bearings:** Slide the shaft through the valve body bore and bearing. Position the disc as stated above and slide the shaft through the disc and outer bearing. Refer to step 4 below.
  - **For CL150 metal bearing, three piece assemblies:** Slide the shaft into the valve body bore and bearing spacer. Position the disc spacer as stated above and hold it in place. Slide the shaft through the bearing and into the disc. Position the second disc spacer, and hold it in place. Slide the shaft through the disc spacer and into the outer bearing.

## Installing the hollow pin and taper pin

4. Place the valve body on a flat working surface with the slot for the seal ring facing *up*. Block the valve body high enough to allow the disc to be rotated into the open position as shown in figure 11.

## Note

**Make sure that the taper pins and hollow pins are free of particulate matter before continuing.**

5. Rotate the disc to the open position. Locate the disc position mark on the end of the drive shaft. Rotate the shaft until it is in the appropriate disc position as shown in figure 7.
6. Line up both holes in the disc hub with the holes in the drive shaft (key 8). (Note: The hole in the drive shaft is offset to prevent the shaft from being installed in the wrong position. Be sure the hole in the shaft is lined up with the hole in the disc hub.)
7. Insert the hollow pins (key 9), into the disc hub as shown in figure 11.

Using the tool shown in figure 11, tap the hollow pin down into the disc hub and shaft until the pin bottoms on the stop in the disc.

8. Insert the taper pins (key 10) into the hollow pins. Using a flat end punch, drive the taper pins into the hollow pins until solid contact is felt. Anchor the pins in place by staking them with a center-punch and hammer. The disc and shaft should rotate smoothly.
9. Install the seal ring assembly using the appropriate instructions in the Seal Ring Maintenance procedures.
10. Install the packing parts using the appropriate instructions provided in the Packing Maintenance procedures. Refer to the Actuator Mounting and Adjustment procedures before installing the valve in the pipeline.

## **Disc, Shaft Assembly and Bearing Maintenance for NPS 2**

This procedure is to be performed to replace the valve disc, shaft, and taper pin assembly if the disc does not rotate in response to rotation of the actuator end of the valve shaft. Unless otherwise indicated, part key numbers are shown in figure 13.

## Disassembly

1. Remove the seal ring according to steps 1 through 5 of the Replacing Seal Ring section.

## CAUTION

**Use a wheel puller to separate actuator parts from the valve shaft. Driving the parts off the valve shaft could move the valve bearings and disc away from the centered position, damaging the disc and valve.**

2. Remove the cap screws and if used the hex nuts. Remove the clamp if the strap is used. Remove the actuator from the valve body while referring to the separate actuator instruction manual for assistance.
3. Rotate the disc (key 3) to the fully open position.
4. Locate the half of the disc that has two C markings cast into it as shown in figure 7. Drive the two taper pins (key 3C) out toward the C-marked side of the disc. Attempting to drive the taper pins in the opposite direction only tightens the pins.
5. Unscrew and remove the packing flange nuts (key 12), packing followers (keys 15 and 16), and packing flanges (keys 9 and 10) if used, from both sides of the valve.

Table 6. Recommended Bolt Torques for Actuator/Mounting Cap Screws and Nuts

VALVE SIZE, NPS	RECOMMENDED BOLT TORQUE	
	N•m	lb•ft
<b>CL150 Valves</b>		
2, 3, 4, 6, & 8	88	65
10 & 12	135	100
<b>CL300 Valves</b>		
2, 3, 4, & 6	88	65
8 & 10	135	100
12	183	135

**WARNING**

Once the shaft has been removed in the following step, the disc may fall from the valve body. To avoid personal injury and disc damage, support the disc to prevent it from falling as the shaft is being removed.

6. Pull the shaft out through the actuator side of the valve.
7. Remove the disc from the valve.
8. Remove the packing rings (key 13), the packing washers (key 27, figure 6) if used, and the packing box ring (key 14).
9. If either of the bearings (key 6) require maintenance or replacement, remove them.

**CAUTION**

When replacing a valve disc or shaft, a new disc/shaft/taper pin assembly (key 3) should be used. Using a new disc with a used shaft requires drilling and reaming new taper pin holes in the shaft. The extra set of taper pin holes weakens the shaft and may cause it to fail in service.

10. Clean the packing boxes and metal packing box parts.

**Assembly**

1. Drop in the new bearings. Make sure to orient the tab in the bearing with the slot in the seal.
2. Insert the disc into the valve body. Be certain the taper pin holes in the disc are on the actuator side of the valve. Also be certain the letter C stamped on either face of the disc is on the same side of the

valve as the letter C stamped on the outside of the valve (figure 7).

3. Slide the shaft through the valve body and disc.
  4. Install the disc and spacers into the valve body. Insert the shaft into the valve body and through the disc.
  5. Slide the shaft all the way into the valve body.
  6. To ensure that the direction of taper in the shaft taper pin holes matches that of the disc taper pin holes, temporarily install the packing follower (key 15) or, if used, the packing flange (key 9) with rotation tag (key 19). With the disc fully opened, rotate the shaft until the line on the end of the shaft indicates the OPEN position as shown in figure 7. Insert the taper pins (key 3C), small end first, into the taper pin holes on the C-marked side of the disc. Do not drive in the pins. Remove the packing follower or flange.
  7. Insert a packing box ring (key 14) into each packing box.
  8. Install the packing according to the appropriate instructions presented in steps 5 through 8 of the Replacing Packing section.
  9. Drive in the taper pins securely.
  10. Rotate the disc to the closed position.
- To install the seal ring and complete the assembly, follow the procedures presented in steps 5 through 9 of the Replacing Seal Ring section.

**Actuator Mounting**

Re-install the seal ring and packing rings using the appropriate procedures before installing the actuator or handlever. Mount the actuator on the valve in accordance with the Actuator Mounting section in the actuator or handlever instruction manual.

In the Packing Maintenance/Removing the Actuator steps, you should have noted the position of the mark on the end of the valve shaft, and its relationship to the actuator shaft. If not, determine the configuration needed to match your application.

Be certain that the disc is rotating counterclockwise to open when viewed from the actuator side of the valve and that the disc is not rotated beyond its limits.

1. Orientate the valve drive shaft correctly to match the actuator or handlever position, install the actuator coupling, and hold it in place while matching the actuator mounting pads with each other.
2. Tighten the actuator-mounting cap screws to the appropriate bolt torque from table 6.

# A41 Valve

## CAUTION

The valve disc travel stop in the valve body bore is not to be used as a power actuator travel stop (see figure 7). Use the actuator travel stops to limit the rotation of the valve disc. It is possible damage to the valve component parts may occur if full actuator thrust is applied to the valve disc travel stop.

### Note

To obtain proper shutoff, the closed position of the A41/8560 valves must be set with the disc parallel to the retaining ring. Don't use the disc stop to set the actuator travel stops.

3. Adjust the actuator travel stop to limit the open and closed positions of the valve disc. (If necessary, refer to the actuator instruction manual for more information about adjustments.) Do not use the disc stop as a actuator travel stop as discussed in the **Caution** above.
4. For actuators with adjustable turnbuckles, adjust the turnbuckle to bring the disc to the fully closed position at the end of the actuator stroke. If necessary, refer to the appropriate actuator instruction manual for assistance.
5. If using a manual handwheel or handlever actuator, refer to the appropriate actuator instruction manual for mounting positions and adjustments.
6. To determine the fully closed disc position (zero degrees of disc rotation), measure the distances between the positions on the disc face as shown in figure 7. Use the actuator to rotate the disc while re-checking the two measurements. Repeat adjustment until the two measurements are equal.

## Parts Ordering

When corresponding with your Emerson Process Management sales office about this equipment, always mention the valve serial number. When ordering replacement parts, also specify the key number, part name, desired material, using the Parts List table.

### WARNING

**Use only genuine Fisher replacement parts. Components that are not supplied by Emerson Process Management should not, under any circumstances, be used in any Fisher valve, because they may void your warranty, might adversely affect the performance of the valve, and could cause personal injury and property damage.**

#### Note

**Neither Emerson, Emerson Process Management, nor any of their affiliated entities assumes responsibility for the selection, use, or maintenance of any product. Responsibility for the selection, use, and maintenance of any product remains with the purchaser and end user.**

## ENVIRO-SEAL Packing Arrangements

Retrofit kits and repair kits are listed in the following tables. For additional parts and repair information, refer to the ENVIRO-SEAL Packing System for Rotary Valves Instruction Manual (Form 5305) or contact your Emerson Process Management sales office for assistance.

### Retrofit Kits for ENVIRO-SEAL Packing

Retrofit kits include new parts for the key numbers listed in the table below (see figure 6 for part locations).

Parts Included in Kit	
Key	Description
100	Packing stud
101	Packing nut
102	Packing flange
103	Spring pack ass'y
105	Packing set
106	Anti-extrusion washer
107	Packing box ring
111	Tag
112	Tie cable

1. Diameter through the packing box.

# A41 Valve

### ENVIRO-SEAL Packing System Retrofit Kits For Fisher A41

SHAFT DIAMETER		SINGLE PTFE PACKING		GRAPHITE PACKING	
mm	Inches	For Actuator End Packing Box		For Actuator End Packing Box	
12.7	1/2	RRTYXRT0972		RRTYXRT1072	
15.9	5/8	RRTYXRT0982		RRTYXRT1082	
19.1	3/4	RRTYXRT0992		RRTYXRT1092	
25.4	1	RRTYXRT1012		RRTYXRT1102	
31.8	1-1/4	RRTYXRT1022		RRTYXRT1112	
38.1	1-1/2	RRTYXRT1032		RRTYXRT1122	

## Repair Kits for ENVIRO-SEAL Packing

Repair kits include replacement parts for key 105 and 106 for the shaft diameters listed below.

### ENVIRO-SEAL Packing Repair Kits

SHAFT DIAMETER(1)	
mm	Inches
12.7	1/2
15.9	5/8
19.1	3/4
25.4	1
31.8	1-1/4
38.1	1-1/2
Parts Included in Kit	
Key	Description
105	Packing set
106	Anti-extrusion washer

1. Diameter through the packing box.

Key	Description	Part Number
4*	Seal Ring (continued)	
	NPS 8	75B0311X022
	NPS 10	75B0312X022
	NPS 12	75B0313X022
	Glass filled PTFE	
	NPS 2	75B0387X032
	NPS 3	75B0020X032
	NPS 4	75B0042X032
	NPS 6	75B0003X032
	NPS 8	75B0311X032
	NPS 10	75B0312X032
	NPS 12	75B0313X032
	NOVEX S31600 SST	
	NPS 2	17A7544X022
	NPS 3	75B1108X012
	NPS 4	75B1109X012
	NPS 6	75B1110X012
	NPS 8	75B0341X012
	NPS 10	75B1112X012
	NPS 12	75B1113X012
	NOVEX S21800	
	NPS 3	75B1108X022
	NPS 4	75B1109X022
	NPS 6	75B1110X022
	NPS 8	75B0341X022
	NPS 10	75B1112X022
	NPS 12	75B1113X022
	Phoenix III S31600/PTFE	
	NPS 3	75B1115X012
	NPS 4	75B1116X012
	NPS 6	75B1117X012
	NPS 8	75B0351X012
	NPS 10	75B0337X012
	NPS 12	75B0339X012
	Spring	
	S31600 SST	
	NPS 2	12A9022X012
	NPS 3	75B0021X012
	NPS 4	75B0043X012
	NPS 6	75B0004X012
	NPS 8	75B0012X012
	NPS 10	75B0029X012
	NPS 12	75B0036X012
	R30003	
	NPS 2	12A9022X062
	NPS 3	75B0021X052
	NPS 4	75B0043X052
	NPS 6	75B0004X052
	NPS 8	75B0012X052
	NPS 10	75B0029X052
	NPS 12	75B0036X052

## Parts List

### Note

Part numbers are shown for recommended spares only. For part numbers not shown, contact your Emerson Process Management sales office.

Key	Description	Part Number
1	Valve Body	
	If you need a new valve body, please order by valve size, serial number and desired material.	
2*	Seal Retainer	See following table
3	Valve Disc	
3	Disc/Shaft Assembly, NPS 2 only	
4*	Seal Ring	
	PTFE	
	NPS 2	75B0387X012
	NPS 3	75B0020X012
	NPS 4	75B0042X012
	NPS 6	75B0003X012
	NPS 8	75B0311X012
	NPS 10	75B0312X012
	NPS 12	75B0313X012
	UHMWPE	
	NPS 2	75B0387X022
	NPS 3	75B0020X022
	NPS 4	75B0042X022
	NPS 6	75B0003X022

Key	Description	Part Number	Key	Description	Part Number																										
6*	Bearing (2 req'd) PEEK/PTFE		16*	Gasket, Graphite w/ Metal and Phoenix III seals																											
	NPS 2	75B0620X012		NPS 3	75B1124X022																										
	NPS 3			NPS 4	75B1124X032																										
	CL150	75B1066X012		NPS 6	75B1124X042																										
	CL300	75B1073X012		NPS 8	75B1545X012																										
	NPS 4			NPS 10	75B1545X022																										
	CL150	75B1067X012		NPS 12	75B1545X032																										
	CL300	75B1074X012	17	Hex Socket Cap Screw																											
	NPS 6		18	Mfg Label																											
	CL150	75B1068X012	19	Drive Screw, w/ nameplate																											
	CL300	75B1075X012	20	Hex Nut																											
	PEEK/PTFE		21	Nameplate																											
	NPS 8		22	Lead Seal & Wire																											
	CL150	75B1069X012	23	Bottom Cap, 12-inch only																											
	CL300	75B1076X012	24	Bottom Cap Stud, 12-inch only																											
	NPS 10		25	Bottom Cap Hex Nut, NPS 12 only																											
	CL150	75B1070X012	27*	Bottom Cap Gasket, NPS 12 only																											
	CL300	75B1077X012		PTFE	75B1186X022																										
	NPS 12			Graphite	75B1186X012																										
	CL150	75B1071X012	29	Flow Arrow, NPS 3-12																											
	CL300	75B1078X012	30	Retainer Clip, NPS 2 only																											
316/Nitride			<b>Packing</b>																												
NPS 2		75B0599X012	<table border="1"> <thead> <tr> <th rowspan="2">SHAFT DIAMETER</th> <th colspan="2">VALVE SIZE</th> </tr> <tr> <th>CL150</th> <th>CL300</th> </tr> </thead> <tbody> <tr> <td>1/2</td> <td>2 &amp; 3</td> <td>2</td> </tr> <tr> <td>5/8</td> <td>4</td> <td>3</td> </tr> <tr> <td>3/4</td> <td>6</td> <td>4</td> </tr> <tr> <td>1</td> <td>8</td> <td>6</td> </tr> <tr> <td>1-1/4</td> <td>10</td> <td>8</td> </tr> <tr> <td>1-1/2</td> <td>12</td> <td>10</td> </tr> <tr> <td>1-3/4</td> <td>- - -</td> <td>12</td> </tr> </tbody> </table>			SHAFT DIAMETER	VALVE SIZE		CL150	CL300	1/2	2 & 3	2	5/8	4	3	3/4	6	4	1	8	6	1-1/4	10	8	1-1/2	12	10	1-3/4	- - -	12
SHAFT DIAMETER	VALVE SIZE																														
	CL150	CL300																													
1/2	2 & 3	2																													
5/8	4	3																													
3/4	6	4																													
1	8	6																													
1-1/4	10	8																													
1-1/2	12	10																													
1-3/4	- - -	12																													
NPS 3			<b>Note</b>																												
CL150		75B1136X012	Part numbers in this section are listed by shaft diameter (inches).																												
CL300		75B1099X012	<b>Key</b>	<b>Description</b>	<b>Part Number</b>																										
NPS 4			100	Packing Stud (2 req'd)																											
CL150		75B1136X022	101	Packing Nut (2 req'd)																											
CL300		75B1100X012	102	Packing Flange																											
NPS 6			103	Spring Pack Assembly, ENVIRO-SEAL & KALREZ®																											
CL150		75B1136X032	105*	Packing Set																											
CL300		75B1101X012		PTFE/Carbon filled PTFE																											
NPS 8				1/2 inch	12A9016X022																										
CL150		75B1136X042		5/8 inch	1R5795X0012																										
CL300		75B1102X012		3/4 inch	12A8995X022																										
NPS 10				1-inch	12A8832X022																										
CL150		75B1136X052		1-1/4 inch	12A8951X022																										
CL300		75B1103X012		1-1/2 inch	12A8935X022																										
NPS 12				1-3/4 inch	12A9057X022																										
CL150		75B1136X062		ENVIRO-SEAL PTFE																											
CL300		75B1104X012		1/2 inch	12B7053X012																										
7*	Disc Spacer w/ Metal Brgs, CL150 only (2 req'd)			5/8 inch	12B7402X012																										
NPS 3		75B1176X012		3/4 inch	12B7414X012																										
NPS 4		75B1176X022		1-inch	12B7438X012																										
NPS 6		75B1176X032		1-1/4 inch	12B7450X012																										
NPS 8		75B1176X042		1-1/2 inch	12B7462X012																										
NPS 10		75B1176X052		1-3/4 inch	14B3049X012																										
NPS 12		75B1176X062																													
8*	Drive Shaft	See following table																													
9*	Hollow Pin	See following table																													
10*	Taper Pin	See following table																													
13*	Bearing Spacer (2 req'd) w/ Metal Brgs, CL150 only																														
	NPS 3	75B1137X012																													
	NPS 4	75B1137X022																													
	NPS 6	75B1137X032																													
	NPS 8	75B1137X042																													
	NPS 10	75B1137X052																													
	NPS 12	75B1137X062																													
14	Hex Head Cap Screw, Steel																														
14	Stud Bolt, SST																														
15*	Backup Ring	See following table																													

\*Recommended spare parts

# A41 Valve

Key	Description	Part Number	Key	Description	Part Number
105*	Packing Set (continued)		107*	Packing Box Ring	
	ENVIRO-SEAL Graphite			Standard and ENVIRO-SEAL Packing	
	1/2 inch	13B8816X012		1/2 inch	16A6082X012
	5/8 inch	13B8816X032		5/8 inch	16A6083X012
	3/4 inch	13B8816X052		3/4 inch	16A6084X012
	ENVIRO-SEAL Graphite			1-inch	16A6085X012
	1-inch	13B8816X092		1-1/4 inch	16A6086X012
	1-1/4 inch	13B8816X112		1-1/2 inch	16A6087X012
	1-1/2 inch	13B8816X142		1-3/4 inch	12A9058X012
	1-3/4 inch	13B8816X152		KALREZ	
	KALREZ/PTFE			1/2 inch	14B6188X012
	1/2 inch	24B6254X012		5/8 inch	14B6190X012
	5/8 inch	24B6254X022		3/4 inch	14B6191X012
	3/4 inch	24B6254X032		1-inch	14B6195X012
	1-inch	24B6254X052		1-1/4 inch	14B6197X012
	1-1/4 inch	24B6254X062		1-1/2 inch	14B6198X012
	1-1/2 inch	24B6254X072	108*	Packing Ring, Graphite Ribbon	
	KALREZ/CRCC			1/2 inch	12A9134X012
	1/2 inch	24B6255X012		5/8 inch	12A9135X012
	5/8 inch	24B6255X022		3/4 inch	12A9136X012
	3/4 inch	24B6255X032		1-inch	12A9137X012
	1-inch	24B6255X052		1-1/4 inch	12A9138X012
	1-1/4 inch	24B6255X062		1-1/2 inch	12A9139X012
	1-1/2 inch	24B6255X072		1-3/4 inch	12A9140X012
106*	Anti-Extrusion Ring, ENVIRO-SEAL PTFE		111	Tag	
	1/2 inch	12B7054X012	114	Packing Follower	
	5/8 inch	12B7406X012	115	Packing Washer, Graphite Ribbon	
	3/4 inch	12B7418X012		1/2 inch	14A8362X012
	1-inch	12B7442X012		5/8 inch	14A9771X012
	1-1/4 inch	12B7454X012		1-inch	14A8365X012
	1-1/2 inch	12B7466X012		1-1/4 inch	14A8366X012
	1-3/4 inch	14B3045X012		1-1/2 inch	14A8367X012
				1-3/4 inch	14A9772X012

Key 2\*. Seal Retainer

VALVE STYLE	VALVE SIZE, NPS	MATERIAL					
		Steel	CF8M	CG8M	CN7M	CW2M	M35-1
<b>PTFE Seal Ring</b>							
Wafer	2	75B0385X012	75B0385X022	75B0385X032	75B0385X042	75B0385X062	75B0385X052
	3	75B0019X012	75B0019X022	75B0019X032	75B0019X042	75B0019X062	75B0019X052
	4	75B0041X012	75B0041X022	75B0041X032	75B0041X042	75B0041X062	75B0041X052
	6	75B0002X012	75B0002X022	75B0002X032	75B0002X042	75B0002X062	75B0002X052
	8	75B0010X012	75B0010X022	75B0010X032	75B0010X042	75B0010X062	75B0010X052
	10	75B0027X012	75B0027X022	75B0027X032	75B0027X042	75B0027X062	75B0027X052
	12	75B0034X012	75B0034X022	75B0034X032	75B0034X042	75B0034X062	75B0034X052
<b>NOVEX and Phoenix III Seal Ring</b>							
Wafer	2	21B4667X012	21B4667X022	---	---	---	---
	3	75B1040X012	75B1040X072	75B1040X082	---	---	---
	4	75B1041X012	75B1041X072	75B1041X082	---	---	---
	6	75B1042X012	75B1042X072	75B1042X082	---	---	---
	8	75B1539X012	75B1539X022	75B1539X032	---	---	---
	10	75B1540X012	75B1540X022	75B1540X032	---	---	---
	12	75B1541X012	75B1541X022	75B1541X032	---	---	---
<b>PTFE Seal Ring</b>							
Single Flange	3	75B0085X012	75B0085X022	75B0085X032	75B0085X042	75B0085X062	75B0085X052
	4	75B0078X012	75B0078X022	75B0078X032	75B0078X042	75B0078X062	75B0078X052
	6	75B0050X012	75B0050X022	75B0050X032	75B0050X042	75B0050X062	75B0050X052
	8	75B0060X012	75B0060X022	75B0060X032	75B0060X042	75B0060X062	75B0060X052
	10	75B0067X012	75B0067X022	75B0067X032	75B0067X042	75B0067X062	75B0067X052
	12	75B0074X012	75B0074X022	75B0074X032	75B0074X042	75B0074X062	75B0074X052
<b>NOVEX and Phoenix III Seal Ring</b>							
Single Flange	3	75B1047X132	75B1047X072	75B1047X082	---	---	---
	4	75B1048X132	75B1048X072	75B1048X082	---	---	---
	6	75B1049X132	75B1049X072	75B1049X082	---	---	---
	8	75B1542X012	75B1542X022	75B1542X032	---	---	---
	10	75B1543X012	75B1543X022	75B1543X032	---	---	---
	12	75B1544X012	75B1544X022	75B1544X032	---	---	---

Key 8\*. Shaft

VALVE SIZE, NPS	MATERIAL				
	S17400 H1075	S20910	N08020	N10276	N05500
<b>CL150</b>					
2 <sup>(1)</sup>	75B0608X012	75B0608X022	75B0608X032	75B0608X042	75B0608X052
3	75B1105X012	75B1105X072	75B1105X132	75B1105X252	75B1105X192
4	75B1105X022	75B1105X082	75B1105X142	75B1105X262	75B1105X202
6	75B1105X032	75B1105X272	75B1105X152	75B1105X272	75B1105X212
8	75B1105X042	75B1105X102	75B1105X162	75B1105X282	75B1105X222
10	75B1105X052	75B1105X112	75B1105X172	75B1105X292	75B1105X232
12	75B1105X062	75B1105X122	75B1105X182	75B1105X302	75B1105X242
<b>CL300</b>					
3	75B1106X022	75B1106X092	75B1106X162	75B1106X302	75B1106X232
4	75B1106X032	75B1106X102	75B1106X172	75B1106X312	75B1106X242
6	75B1106X042	75B1106X112	75B1106X182	75B1106X322	75B1106X252
8	75B1106X052	75B1106X122	75B1106X192	75B1106X332	75B1106X262
10	75B1106X062	75B1106X132	75B1106X202	75B1106X342	75B1106X272
12	75B1106X072	75B1106X142	75B1106X212	75B1106X352	75B1106X282

1. The NPS 2 valve is multi-rated to CL150, 300 and 600.

# A41 Valve

August 2010

*Key 9\*. Hollow Pin (2 req'd)*

VALVE SIZE, NPS	CL150				CL300			
	Shaft Material				Shaft Material			
	S17400 H1075 & S20910	N08020	N10276	N05500	S17400 H1075 & S20910	N08020	N10276	N05500
3	75B1122X012	75B1122X082	75B1122X222	75B1122X152	75B1122X022	75B1122X092	75B1122X232	75B1122X162
4	75B1122X022	75B1122X092	75B1122X232	75B1122X162	75B1122X032	75B1122X102	75B1122X242	75B1122X172
6	75B1122X032	75B1122X102	75B1122X242	75B1122X172	75B1122X042	75B1122X112	75B1122X252	75B1122X182
8	75B1122X042	75B1122X112	75B1122X252	75B1122X182	75B1122X052	75B1122X122	75B1122X262	75B1122X192
10	75B1122X052	75B1122X122	75B1122X262	75B1122X192	75B1122X062	75B1122X132	75B1122X272	75B1122X202
12	75B1122X062	75B1122X132	75B1122X272	75B1122X202	75B1122X072	75B1122X142	75B1122X282	75B1122X212

*Key 10\*. Taper Pin (2 req'd)*

VALVE SIZE, NPS	CL150				CL300			
	Shaft Material				Shaft Material			
	S17400 H1075 & S20910	N08020	N10276	N05500	S17400 H1075 & S20910	N08020	N10276	N05500
2	12A9019X072	12A9019X052	12A9019X042	12A9019X032	12A9019X072	12A9019X052	12A9019X042	12A9019X032
3	19A3749X012	19A3749X042	- - -	19A3749X032	F14119X0052	F14119X0062	F14119X0072	F14119X0082
4	F14119X0052	F14119X0062	F14119X0072	F14119X0082	G11299X0032	G1129940092	G1129940152	G1129940022
6	G11299X0032	G1129940092	G11299400152	G1129940022	F13668X0022	F1366840092	F13668X0032	F1366840022
8	F13668X0022	F1366840092	F13668X0032	F1366840022	G13725K0022	G1372540092	G13725X0082	G1372540022
10	G13725K0022	G1372540092	G13725X0082	G1372540022	75B0333X012	75B0333X022	75B0333X032	75B0333X042
12	75B0333X012	75B0333X022	75B0333X032	75B0333X042	75B0334X012	75B0334X022	75B0334X032	75B0334X042

*Key 15\*. Backup Ring (Use w/ Phoenix III Seal)*

VALVE SIZE, NPS	MATERIAL				
	EPR	FKM Fluorocarbon	CR Chloroprene	Filled Silicone	NBR
3	75B1123X022	75B1123X092	75B1123X162	75B1123X502	75B1123X442
4	75B1123X032	75B1123X102	75B1123X172	75B1123X512	75B1123X452
6	75B1123X042	75B1123X112	75B1123X182	75B1123X522	75B1123X462
8	V110611X032	V110611X022	V110611X042	V110611X072	V110611X062
10	75B0344X012	75B0344X022	75B0344X032	75B0344X062	75B0344X052
12	75B0340X012	75B0340X022	75B0340X032	75B0340X062	75B0340X052

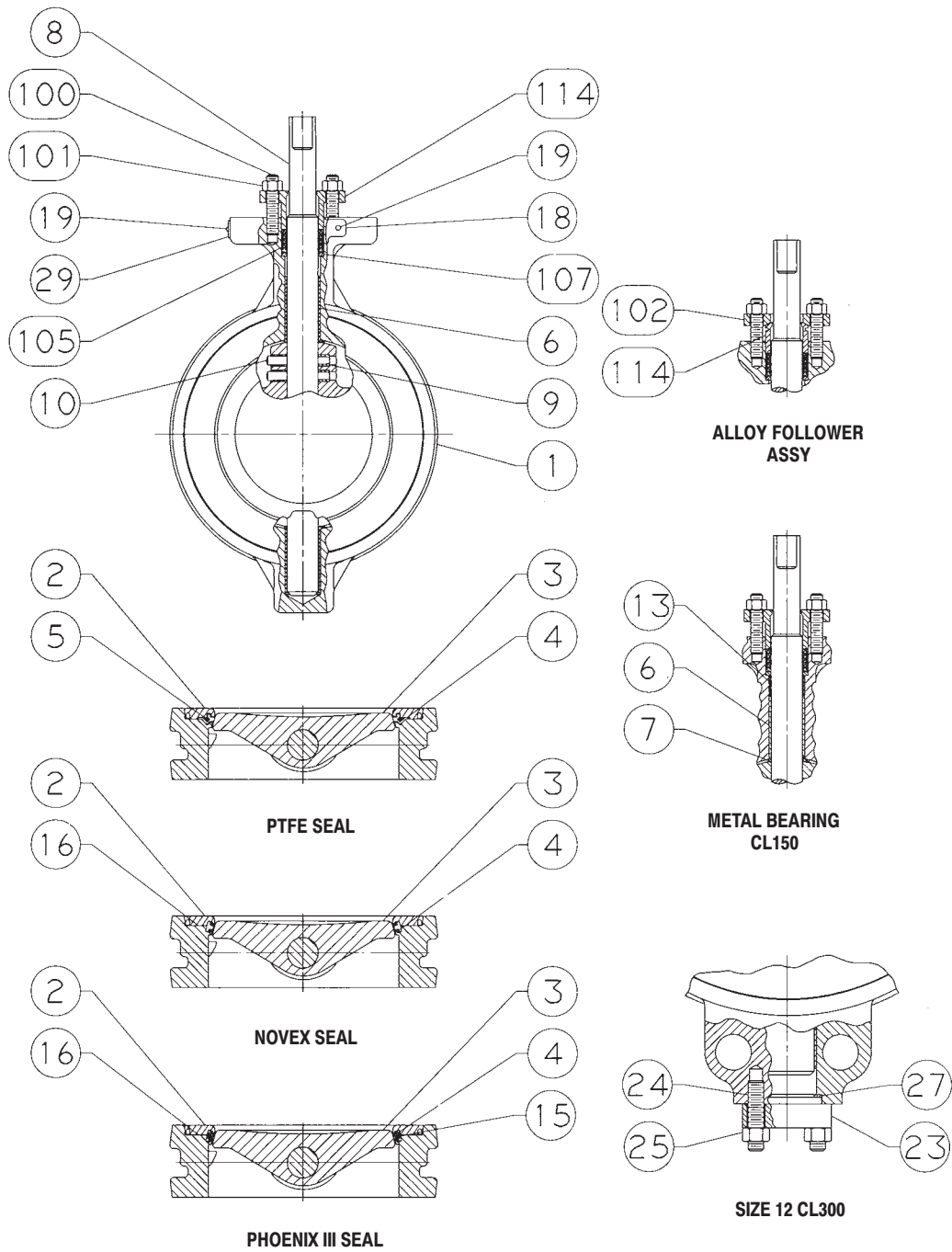

NOTE:  
KEYS 21, 22, AND 28 ARE NOT SHOWN.

75B0094-B

Figure 12. Wafer Valve Assembly for the NPS 3 through 12

# A41 Valve

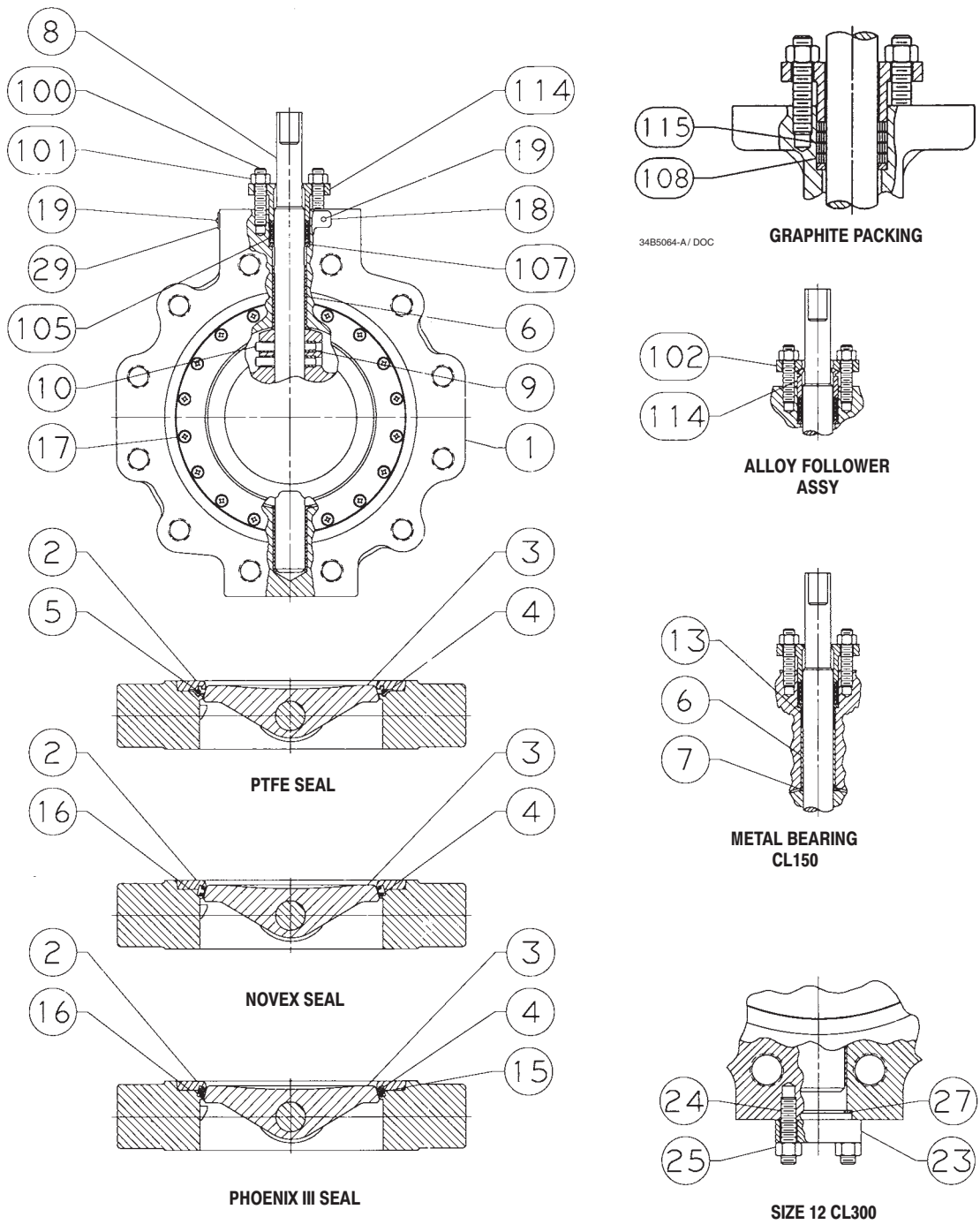

NOTE:  
KEYS 21, 22, AND 28 ARE NOT SHOWN

75B0096-B

Figure 12. Wafer Valve Assembly for the NPS 3 through 12 (continued)

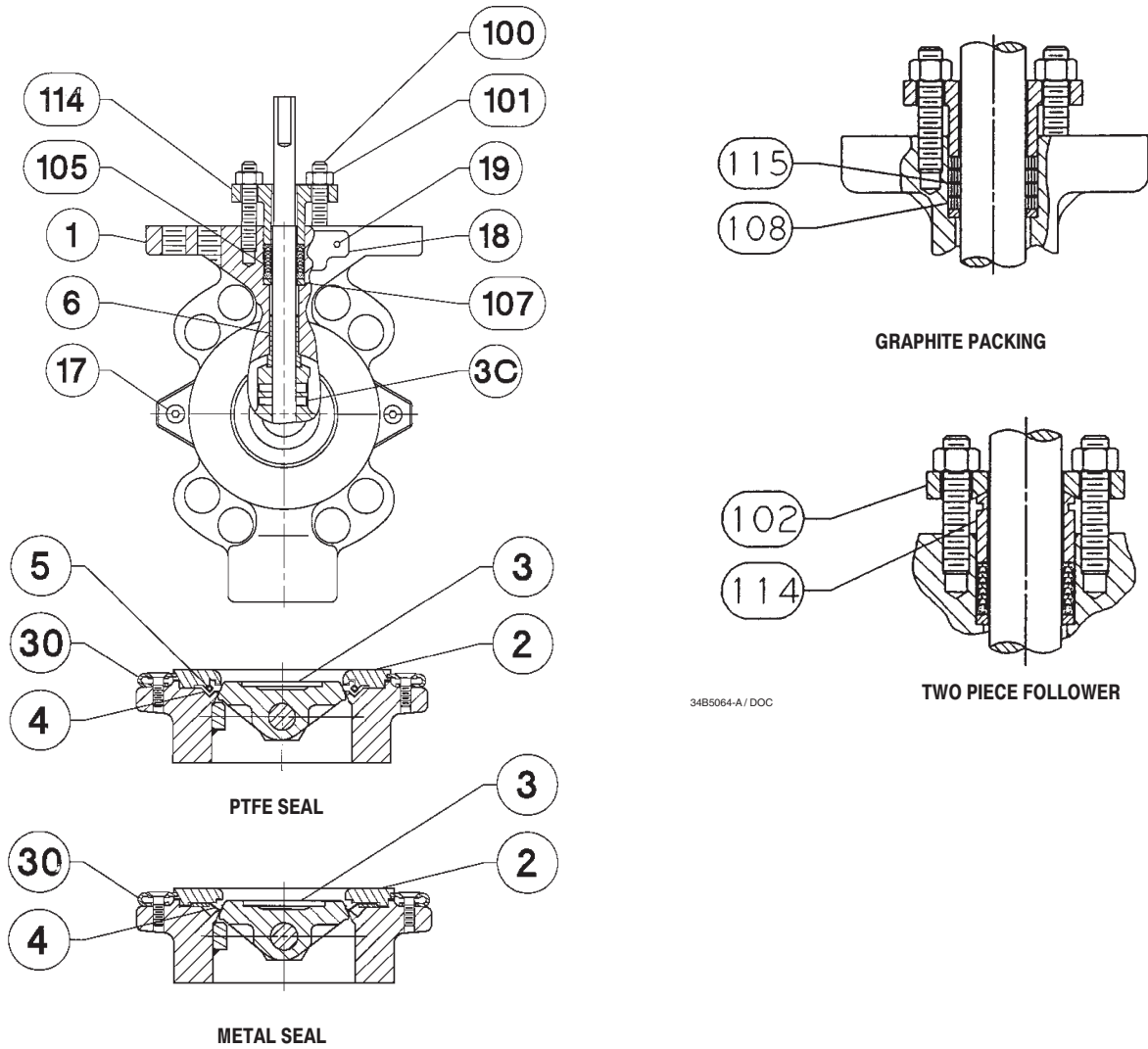

34B5064-A / DOC

NOTE: PARTS 21 AND 22 NOT SHOWN  
75B0625

Figure 13. Valve Assembly for NPS 2

# A41 Valve

---

Fisher and ENVIRO-SEAL are marks owned by one of the companies in the Emerson Process Management business division of Emerson Electric Co. Emerson Process Management, Emerson, and the Emerson logo are trademarks and service marks of Emerson Electric Co. KALREZ is a mark owned by E.I. duPont De Nemours Co. All other marks are the property of their respective owners.

The contents of this publication are presented for informational purposes only, and while every effort has been made to ensure their accuracy, they are not to be construed as warranties or guarantees, express or implied, regarding the products or services described herein or their use or applicability. All sales are governed by our terms and conditions, which are available upon request. We reserve the right to modify or improve the designs or specifications of such products at any time without notice. Neither Emerson, Emerson Process Management, nor any of their affiliated entities assumes responsibility for the selection, use or maintenance of any product. Responsibility for proper selection, use, and maintenance of any product remains solely with the purchaser and end user.

**Emerson Process Management**

Marshalltown, Iowa 50158 USA

Sorocaba, 18087 Brazil

Chatham, Kent ME4 4QZ UK

Dubai, United Arab Emirates

Singapore 128461 Singapore

[www.Fisher.com](http://www.Fisher.com)