

RELEASE RELAY

CONTENTS

Release Relay (OS2)	1 to 3
Introduction	1
Mechanism Box	2
Safety Manometric Box	2
Labelling.....	2
Types of installation	2
Characteristics	3
Dimensions and weights	3
Mechanism Box (BM)	3 to 6
Description and spare parts	3
Operation	4
Connections	4
Materials	5
Commissioning	5
Maintenance	6
Options	6
Safety Manometric Box (BMS)	7 to 12
Description and spare parts	7
Operation	8
Connections	8
Spring adjustment range	8
Materials	10
Adjustment	11
Maintenance	12

INTRODUCTION

The OS2 Release Relay consists of a Mechanism Box (BM) and one or two Safety Manometric Boxes (BMS).
It's function is to provoke the activation of a slam shut valve which may be stand alone (OSE), integrated in a regulator (MP, MPS, DRPNPIL, EZH, DRPN, EZR) or integrated in a K1000/K3000, in the case of under or over pressure in the controlled gas network. It may be mounted on systems of DN 25 to DN 150 and up to PN 100.
It is tight shut and submersible. It may be connected to an explosion-proof contact (intrinsically safe).

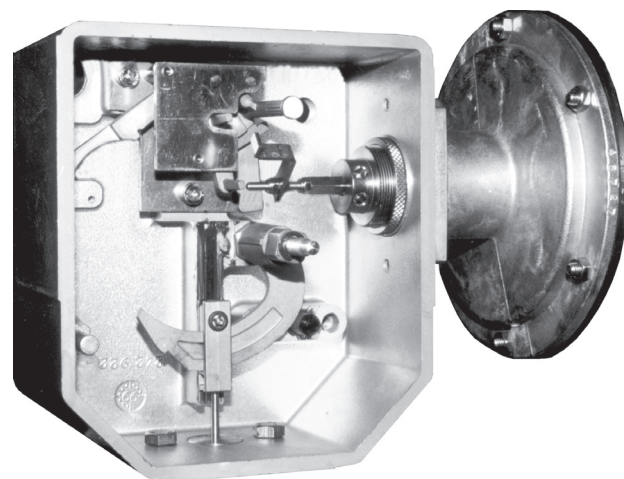

Figure 1. Type OS2

MECHANISM BOX (BM)

The mechanism box is designed to close a slam shut valve. The operation is ensured in two successive stages: a detection stage and a power stage. The separation between the detection stage and the power stage provides maximum precision, indifferent of working pressure, slam shut valve diameter and gas flow. After activation of the slam shut valve due to over or under pressure, the mechanism box must be reset manually. The complete system is available, on request only, sealed with lead and wire.

SAFETY MANOMETRIC BOX (BMS)

The pressure data is transformed into a displacement by a safety manometric box (BMS 1) mounted on the mechanism box (BM). This displacement is used to activate the detection stage of the mechanism box in the case of overpressure, over or underpressure, or underpressure condition.
In certain configurations, a second box may be used (BMS 2).

Type OS2

LABELLING

BMS Taille Size	See table 1	PSD BMS	See table 1	bar
N° Série Serial		AG maxi	See table 1	
FRANCEL	Ressort/Spring Ø			mm
Wdsu		Δ1		bar

Figure 2. Maxi Pressure Triggering

BMS Taille Size	See table 1	PSD BMS	See table 1	bar
N° Série Serial		AG maxi	See table 1	
FRANCEL	Ressort/Spring Ø			mm
Wdsu		Δ1		bar

Figure 3. Mini Pressure Triggering

BMS Taille Size	See table 1	PSD BMS	See table 1	bar
N° Série Serial		AG maxi	See table 1	
FRANCEL	Ressort/Spring Ø			mm
Wdsu		Δ1		bar
Wdsu		Δ2		bar

Figure 4. Maxi & Mini Pressure Triggering

Size	162	071	027	017	236	315
PSD	10 bar	20 bar	100 bar	100 bar	35 bar	72 bar
AG maxi	2.5	2.5	5	5	2.5	2.5

Table 1. Type OS2 Pressures

See tables 14, 15 and 16 for other values

TYPES OF INSTALLATION

Mounting on horizontal pipeline only:

Top Mounted (stand-alone valve)

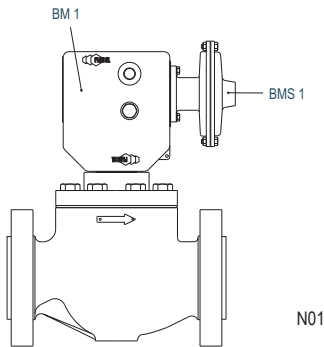

Figure 5. BM 1: Mechanism Box with One Safety Manometric Box (BMS 1)

Bottom Mounted (integrated valve and regulator)

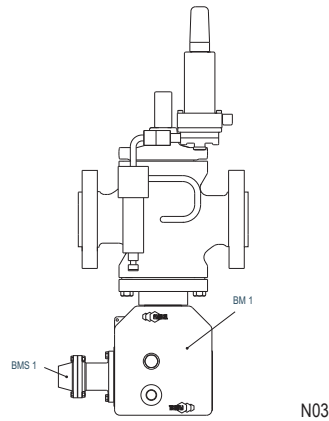

Figure 6. BM 1: Mechanism Box with One Safety Manometric Box (BMS 1)

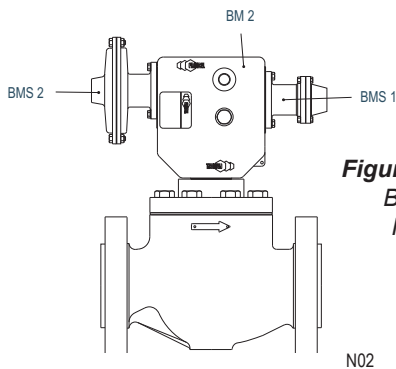

Figure 7. BM 2: Mechanism Box with Two Safety Manometric Boxes (BMS 1, BMS 2)

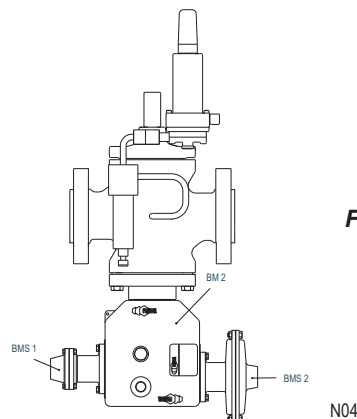

Figure 8. BM 2: Mechanism Box with Two Safety Manometric Boxes (BMS 1, BMS 2)

CHARACTERISTICS

Accuracy	AG 2.5	Diaphragm or bellows
	AG 5	Piston
Memorization	No memorization	
Resistance to vertical shocks	4 J	(20 shocks)
Resistance to pendular shocks	9.81 J	(20 shocks)
Sealing	IP 67	Temporary immersion
Maximum operating pressure (PSD)	100 bar	
Operating temperature	-30°C to +71°C	
Max. valve travel	50 mm	

DIMENSIONS AND WEIGHTS

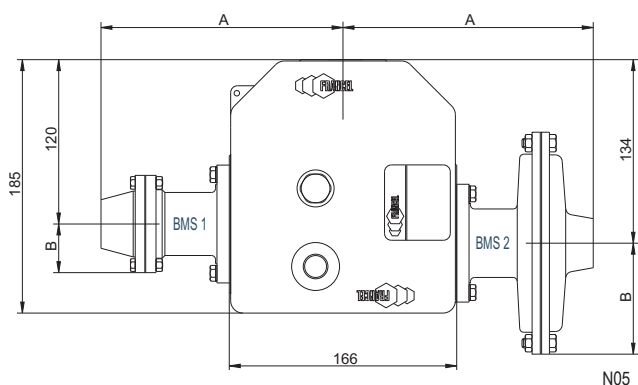

Figure 9. Dimensions

DESCRIPTION AND SPARE PARTS (BM)

Table 3. Mechanism Box Assembly

Item	Description	BM 1	BM 2
	Mechanism box	181 067	181 068
1	Cap including indicator, O-ring and screw (new version 06/2007; interchangeable)	181 328	
	New cap O-ring	145 430	
2	Mechanism box casing	142 924	144 071
3	Box gasket	142 930*	
	BMS gasket	145 431A*	
	BMS screw	402 018*	
	BMS sealing screw o-rings	461 150*	
4	Non-connectable brace vent	27A5516X012	
	Vent link for 8x10 tube	406 526	
5	Yoke	181 042	
	Fixed bolt axe (do not dismount)	142 920	
6	Bolt	181 043	
	Truarc o-ring	406 128	
7	Travel stop	140 324	
	Damper	127 692	
8	Mechanism	181 041	
	Mechanism screw	402 512	
9	Resetting tool	242 915	

* Sold as a set ref. n° 197 351.
Items in bold are spare parts

Table 2. Dimensions and Weights

	Type	DIMENSIONS (mm)		WEIGHTS (kg)	
		A	B		
BM	BM 1	For 1 BMS		2.5	
	BM 2	For 2 BMS		2.5	
BMS	162	Diaphragm	181	83	2.6
	71	Diaphragm	175	36	1.2
	27 or 17	Piston	204	36	2.3
	236	Bellows	202	36	2.4
	315	Bellows	223	36	2.8

For an OS2 with one BMS add the weight of the BMS to that of the BM 1.
For an OS2 with two BMS add the weight of the two BMS to that of the BM 2.

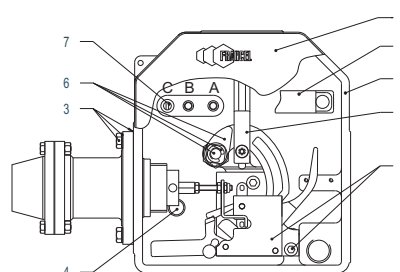

Figure 10. Mechanism Box for One BMS

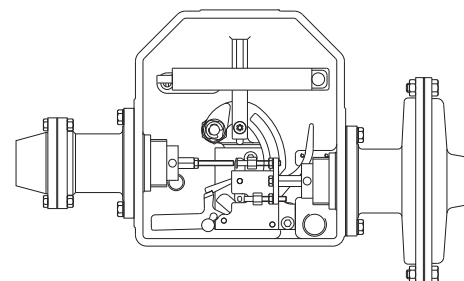

Figure 11. Mechanism Box for Two BMSs

CONNECTIONS

Table 4. Connection Types

Connection Type	Connection Description	Thread
Non connectable	Plastic vent with screen	1/4" NPT
Connectable	Link for 8/10 tube	1/4" NPT
Contact	Box exit	1/2" NPT

DESCRIPTION AND SPARE PARTS (BM)

Table 5. Packing Gland Assembly

Description	Packing gland		
	Valve		
	OSB	VSE	Standard
Assembly	181 089	181 090	181 104
Packing gland and stem	181 040		181 040
Packing gland		144 126	
O-ring	400 514	400 505	400 514
O-ring		400 221	
Fastening screw H M7	402 028		402 028
Fastening screw H M8		402 036	402 036
Flat washer (7)	405 005		405 005
Flat washer (8)		405 006	405 006

Items in bold are spare parts

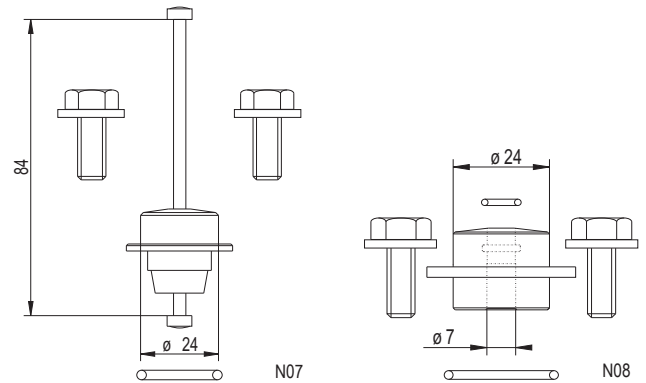

Figure 12. Standard Packing Gland

Figure 13. VSE Packing Gland

OPERATION (BM)

The detection stage consists of two parts:

- the releasing stem (1),
- the 1st stage trigger (2).

Through the intermediate of the safety manometric box (BMS), the pressure provokes a pin movement (D1 or D2), which provokes the rotation of the releasing stem (1) and frees the 1st stage trigger (2).

The power stage consists of two parts:

- the 2nd stage trigger (3),
- the cam (4).

The 2nd stage trigger (3), activated by the 1st stage trigger (2), frees the cam (4), which provokes the valve to close.

After release, the resetting is ensured in two stages: (detection stage, then power stage) see "commissioning".

Position indicator

The position of the detection stage can be seen through the position indicator glass.

Memorization

The releasing stem will only start moving when pressure approaches the pressure set point. In all other cases, it remains fixed. Furthermore the assembly has a very high resistance to shocks. If pressure approaches the set point, the releasing stem turns, but with the slightest shock or vibration it will go back to its initial position and pressure returns to normal. The mechanism is said to be non memorizing.

Resistance to shocks

This assembly has a remarkable resistance to shocks (20 vertical shocks of 4 J and 20 pendular shocks of 9.81 J), with pressure close to set point (for example: 186 mbar for a set point of 200 mbar).

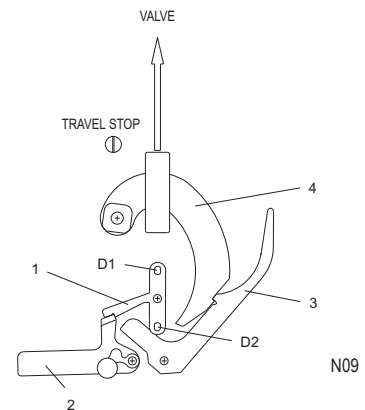

Figure 14. Mechanism Details

CONNECTIONS (BM)

- Fixation BM / Connector:
H M7 or H M8 screws
16 N.m torque
- Sealed BM / Connector:
Flat O-ring (water resistant)
Packing gland (gas resistant)
- Mechanism contact / Slam shut valve:
Control rod
- BM connector / atmosphere:
Integrated vent nipple with screen (supplied) or compression fitting (supplied) for 8/10 tube (not supplied)*
- Electrical connection:
See page 6

* The 8/10 tube should be angle-shaped on the top to avoid water from entering.

MECHANISM BOX (BM) MATERIAL

Table 6. Mechanism Box (BM) Material

Box	Body	Aluminium	Chromatation
	Cover	Aluminium	Chromatation
	Position indicator	Polycarbonate	
	Self-jamming ring	Steel	Phosphatation
	Cover nut	Stainless steel	
	Circlips	Steel	Phosphatation
Mechanism	All parts	Stainless HR	
	Brackets	Brass	
	Bolt	Brass	
	Elastic O-ring	Steel	Phosphatation
	Torsion spring	Stainless steel	
	Traction spring	Bronze	
Yoke	Self-jamming ring	Steel	Phosphatation
O-rings	Flat	EPDM	
	Cover	Neoprene	
	Truarc ring	Nitrile	

Table 7. Packing gland Material

Body	Bronze	
Control rod	Stainless steel	Chromium plating
Truarc ring	Nitrile	

CAUTION

Never use an extension pipe with the reset key when resetting the 2nd stage (max. normal torque 16 N.m, never go over 32 N.m).

WARNING

AUTHORIZED PERSONNEL ONLY

Risk of injury

**After rearming, remove the reset key from the stem.
Do not put fingers in or near the reset mechanism area.**

COMMISSIONING (BM)

Commissioning differs depending on whether the assembly has an internal or external bypass and whether overpressure releasing is required or not. See corresponding technical manuals for further details.

Note

The position of the travel stop (Figure 10, key 7) depends on the type of assembly and its size. Position A, B or C depending on max. travel of slam shut valve: A = 15 mm travel, B = 35 mm travel, C = 50 mm travel.

• Mechanism box (BM) intervention

To access the box the cover must be removed. When unscrewing the nut a circlips is used to remove the O-ring.

The cover is held on by one screw which can be unscrewed manually or using a socket screw key (recommended torque for optimal shutoff: 6 N.m).

• Resetting

To reset the slam shut (after the fault has been settled), the 1st mechanism stage must be reset by manually turning the 1st stage trigger. If the slam shut has an internal bypass the cam must be slightly turned using a resetting key to bypass. If the slam shut has an external bypass, a bypass valve will be used.

In both cases:

Wait for the pressure to be equalized before resetting the 2nd mechanism stage.

When resetting the 2nd mechanism stage (opening of the valve) a reset key is used (delete).

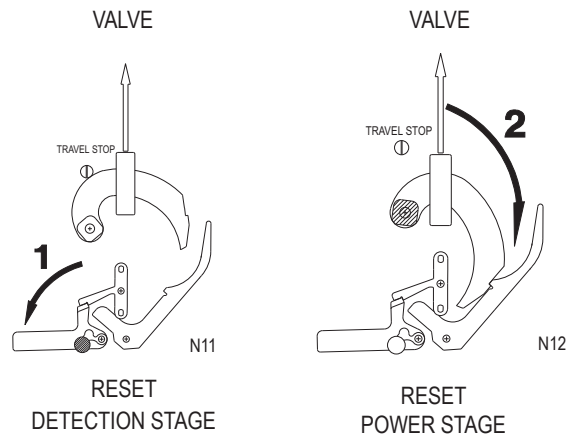
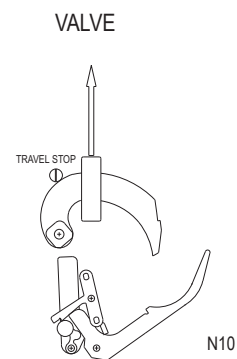

Figure15. Release Activation Stages

Type OS2

MAINTENANCE (BM)

Tools :

- Spanner 11 (screw 7) and 13 (or 14) (screw 8)
- Screwdriver
- Control
 - 1st and 2nd stage mechanism releasing
 - Packing gland is tight shut
 - Yoke greasing
- Disassembly
 - Check that assembly is not under pressure
 - Manual release of slam shut (Figure 14)
 - Manually press on the releasing stem pin D1 or D2 (Figure 14, key 1) parallel to the BMS axe
 - Unscrew the travel stop (screwdriver)
 - Unscrew the BM fastening screws (flat spanner 11 (screw 7) and 13 (or 14) (screw 8))
 - Disassemble the mechanism box (BM) from the connector by unlocking the yoke
- Assembly
 - Proceed in reverse order to disassembly

OPTIONS (BM)

- Remote alert (on BM 1 or BM 2)
 - Detects 2nd stage releasing (power)
- Remote control
 - Atmospheric solenoid valve (releasing by min. pressure) for max. releasing pressure of 30 bar. Safety manometric box (BMS) activated with a pneumatic or electro-pneumatic impulse.
- Manual control on BM 2 with 1 BMS 1 only
 - Push button (connected at the same place as a BMS 2).

Contact

Table 8. Mechanism Box Connections

	AC	DC
Max. intensity	7.0 A	0.8 A
Max. tension	400 V	250 V
Protection	EEx-d IIC T6	
Tightness	IP 66	
Temperature	-29°C +71°C	
Fastening	2 M3 screws	
Cable	3 wires (black, brown, blue) H05VVF (3 x 0.75 mm ²) D 6.5 mm	

Table 9. Mechanism Box Versions

Versions	Installation	Sealing	Connection	Mechanical Connections	Electrical connections			
					Common	NF	NO	Connection
C0		IP 68	Without	1/2 NPT cap				
C1	Explosion proof	IP 68	Explosion proof	3 m wire	Black	Blue	Brown	Wires
C2		IP 65		Explosion proof connector box/PE explosion proof	3	4	5	Screwed wiring
C3	Intrinsic safe	IP 68		Intrinsic safe tight-shut connector	A	B	C	Welded wiring

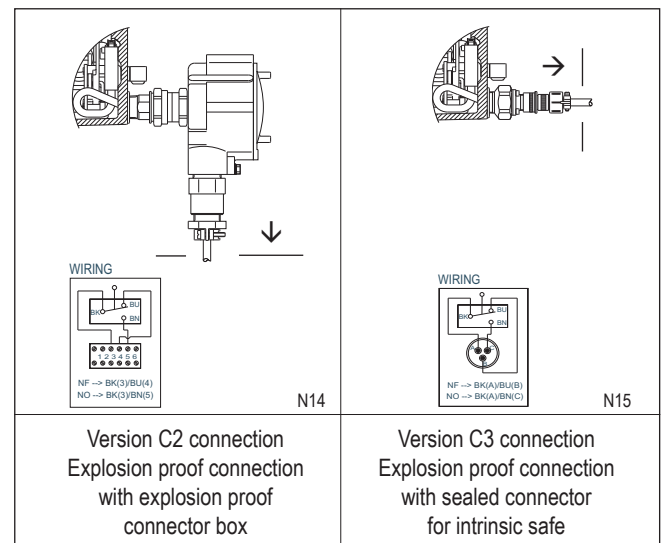
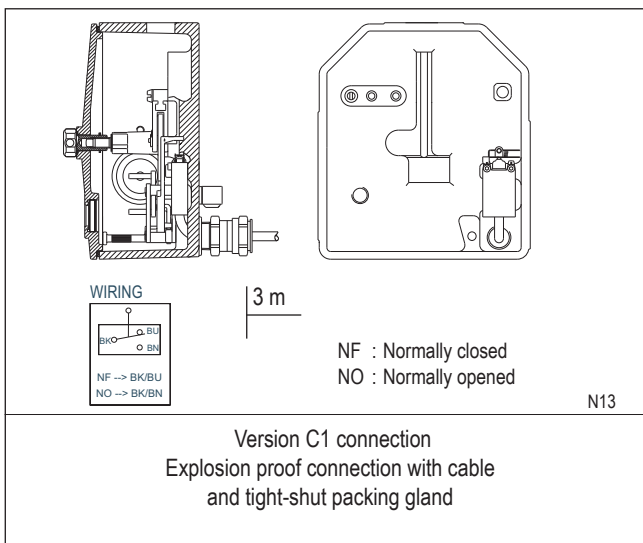

Figure 16. Different Versions of BM Connections

SAFETY MANOMETRIC BOX (BMS) DESCRIPTION AND SPARE PARTS

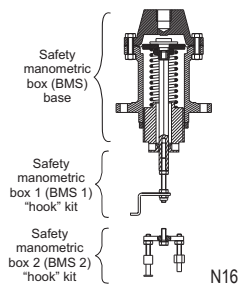

Figure 17. BMS with

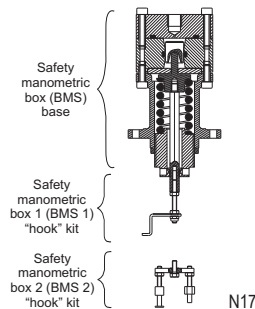

Figure 18. BMS with

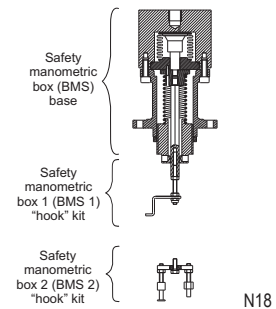

Figure 19. BMS with

Table 10. Spare Parts

Description		Diaphragm (Max. and/or Min.)		Piston (Max. or Min.)		Bellows (Max. and/or Min.)	
		162	71	27	17	236	315
BMS 1	Complete box	181 071	181 072	180 999	180 998	181 073	181 074
	Base	181 105	181 106	181 107	181 108	181 109	181 110
	Hook kit	181 111					
BMS 2	Complete box	181 084	181 085	181 070	181 069	181 086	181 087
	Base	181 105	181 106	181 107	181 108	181 109	181 110
	Hook kit	181 112					
Spare Parts	Diaphragm	137 906	142 549				
	Set of O-rings			197 352			

Items in bold are spare parts

DESCRIPTION (BMS)

- Impulse line

The impulse line (IS) is connected to the network to be protected (normally downstream of the regulator).

- Impulse type

Depending on the pressure and precision required, different types of impulse may be used: Diaphragm, Piston or Bellows.

- Springs

To cover all pressure ranges, a set of springs of equal length and diameter, but of different wire diameter (2 to 6.5 mm), may be used.

- Detection

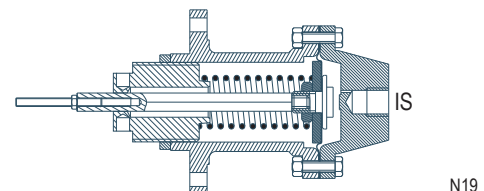

Figure 20. BMS 1 Max. only

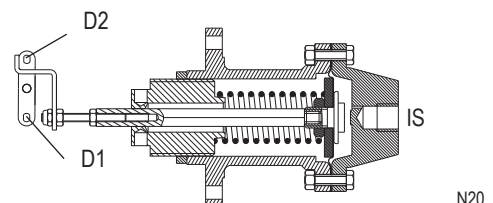

Figure 21. BMS 1 Min. only

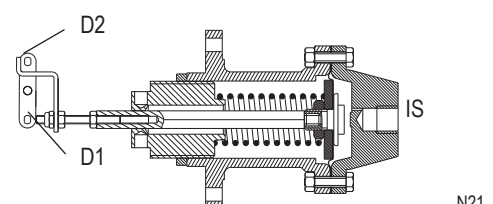

Figure 22. BMS 1 Max.-Min.

Table 11. Detection Configurations

		Actioner	Max. only	Min. only	Max. & Min.
One BMS	BMS 1	Releasing screw	Active	Neutral	Active
		Hook	Neutral	Active	Active
Two BMS	BMS 1	Releasing screw	Active		
		Hook	Neutral		
	BMS 2	Push button	Active	Neutral	Active
		Hook	Neutral	Active	Active

Type OS2

OPERATION (BMS)

The pressure of the network to be protected pushes the diaphragm, piston or bellows.
 The force resulting from this opposes the force (adjustable) coming from the set-point spring.
 When pressure varies, the detection rod moves and provokes releasing by max. or min. pressure.

CONNECTIONS (BMS)

On the mechanism box: 2 H M6x16 screws (code 402018)
 BM sealing: Flat O-ring and tight shut O-rings
 On the manometric box: 1/4" NPT screwed
 Recommended tube: 8/10 mm
 The sensing line must be connected downstream of the regulator.

SPRING ADJUSTMENT RANGES (BMS)

(see definitions page 10)

Table 12. Max Pressure Releasing

Pressure	BMS 1	BMS 2
	Releasing screw	Push button
Normal	Without D1 pin contact	Without D2 pin contact
Increase	With D1 pin contact	With D2 pin contact
= Set point	Rotation of releasing stem and 1 st stage trigger	

Table 13. Min Pressure Releasing

Pressure	BMS 1	BMS 2
	Hook	Hook
Normal	Without D2 pin contact	Without D1 pin contact
Decrease	With D2 pin contact	With D1 pin contact
= Set point	Rotation of releasing stem and 1 st stage trigger	

Table 14. Max. only Spring Adjustment Ranges

MAX. ONLY	BMS			SPRING		MAX. ONLY			INTERVALS
	Type	Size	PMS box (bar)	Ø wire (mm)	Code	Wdso setting (bar)			Δ1
						Max. low pt. possible	Recommended range		Δ1 (bar)
							Max. low pt.	Max. high pt.	
Diaphragm	162	10	2.0	113 195	0.010	0.015	0.035	0.004	
			2.5	113 196	0.025	0.040	0.080	0.005	
			3.0	113 197	0.045	0.080	0.140	0.010	
			3.5	113 198	0.070	0.070	0.240	0.014	
			4.0	113 199	0.115	0.140	0.380	0.018	
			5.0	113 201	0.140	0.300	0.750	0.050	
			5.5	113 202	0.250	0.600	1.3	0.080	
	071	20	4.5	113 200	1.0	2.0	5.1	0.350	
			5.5	113 202	2.1	4.0	11.0	0.700	
			6.5	114 139	4.0	8.0	16.0	1.6	
	Piston	027	100	5.5	113 202	16.0	16.0	22.0	3.0
				6.5	114 139	22.0	22.0	40.0	6.5
		017	100	5.5	113 202	40.0	40.0	55.0	7.0
6.5				114 139	55.0	55.0	100.0	12.0	
Bellows	236	35	5.5	113 202	5.5	11.0	22.0	1.6	
			6.5	114 139	8.3	16.0	35.0	2.5	
	315	72	5.0	113 201	17.5	35.0	72.0	5.0	

SPRING ADJUSTMENT RANGES (BMS) (continued)

Table 15. Min. Only Spring Adjustment Ranges

	BMS			SPRING		MIN. ONLY			INTERVALS
	Type	Size	PMS box (bar)	Ø wire (mm)	Code	Wdsu setting (bar)			Δ1
						Min. low pt. possible	Recommended Range		Δ1 (bar)
							Min. low pt.	Min. high pt.	
MIN. ONLY	Diaphragm	162	10	2.0	113 195	0.010	0.015	0.035	0.004
				2.5	113 196	0.025	0.040	0.080	0.005
				3.0	113 197	0.045	0.080	0.150	0.010
				3.5	113 198	0.070	0.070	0.240	0.014
				4.0	113 199	0.115	0.150	0.400	0.018
				5.0	113 201	0.140	0.300	0.650	0.050
				5.5	113 202	0.250	0.600	1.15	0.080
				6.5	114 139	0.450	1.1	2.0	0.170
	071	20	4.5	113 200	1.0	2.0	4.7	0.350	
			5.5	113 202	2.1	4.0	9.5	0.700	
			6.5	114 139	4.0	8.0	14.4	1.6	
	Piston	027	100	5.5	113 202	16.0	16.0	19.0	3.0
				6.5	114 139	19.0	19.0	38.0	6.5
		017	100	5.5	113 202	38.0	38.0	50.0	7.0
				6.5	114 139	50.0	50.0	90.0	12.0
Bellows	236	35	5.5	113 202	5.5	11.0	16.0	1.6	
			6.5	114 139	8.3	16.0	28.0	2.5	
	315	72	5.0	113 201	17.5	28.0	65.0	5.0	

Table 16. Max. & Min. Spring Adjustment Ranges

	BMS			SPRING		MAX. & MIN.		INTERVALS	
	Type	Size	PMS box (bar)	Ø wire (mm)	Code	Wdsu setting (bar)		Δ1 & Δ2	
						Min. low pt. possible	Max. high pt.	Δ1 (bar)	Δ2 (bar)
MAX. & MIN.	Diaphragm	162	10	2.0	113 195	0.010	0.035	0.004	0.010
				2.5	113 196	0.025	0.080	0.005	0.025
				3.0	113 197	0.045	0.140	0.010	0.050
				3.5	113 198	0.070	0.240	0.014	0.060
				4.0	113 199	0.115	0.380	0.018	0.150
				5.0	113 201	0.140	0.750	0.050	0.350
				5.5	113 202	0.230	1.3	0.080	0.600
				6.5	114 139	0.450	2.3	0.170	1.1
	071	20	4.5	113 200	1.0	5.1	0.350	2.5	
			5.5	113 202	2.1	11.0	0.700	5.5	
			6.5	114 139	4.0	16.0	1.6	10.0	
	Piston	027	<i>Not possible with only 1 BMS</i>						
		017	<i>Not possible with only 1 BMS</i>						
	Bellows	236	35	5.5	113 202	5.5	22.0	1.6	10.0
				6.5	114 139	8.3	35.0	2.5	20.0
315		72	5.0	113 201	17.5	72.0	5.0	33.0	

Type OS2

DEFINITIONS

Table 17. Definitions

PSD box	Maximum operating pressure for box
Pd	Nominal downstream regulator pressure
Pd max	Maximum downstream regulator pressure (normally closing regulator pressure)
Pd min	Minimum downstream regulator pressure (disturbance in function with flow and/or inlet pressure is to be considered)
Pdo	Maximum releasing pressure
Max. high pt.	High regulator pressure at maximum
Max. low pt.	Low regulator pressure at maximum remaining within the accuracy class
Max. low pt. possible	Low regulator pressure at furthest maximum point (precision is not guaranteed)
Pdu	Minimum releasing pressure
Min. high pt.	High minimum regulator pressure
Min. low pt.	Low regulator pressure at minimum remaining within the accuracy class
Min. low pt. possible	Low regulator pressure at furthest minimum point (precision is not guaranteed)
Wdso	Overpressure specific range obtained from slam shut valve
Wdsu	Underpressure specific range obtained from slam shut valve
$\Delta 1$	Minimum difference allowed between Pdo and Pd max. and/or between Pdu and Pd min.
$\Delta 2$	Maximum difference allowed between maximum and minimum releasing pressure

SELECTION GUIDE LINES: PRESSURE LIMITATIONS

Table 18. Pressure Limitations

Max. only	Min. only	Max. & Min.
Pdo \leq PMS box (BMS)	Pd max. < PMS box (BMS)	Pdo \leq PMS box (BMS)
Pdo \leq Max. high pt.	Pdu \leq Min. high pt.	Pdo \leq Max. high pt.
Pdo \geq Max. low pt.	Pdu \geq Min. low pt.	Pdo \geq Pd max. + $\Delta 1$
Pdo \geq Pd max. + $\Delta 1$	Pdu \geq Pd min. - $\Delta 1$	Pdu \geq Min. lowest pt. possible
		Pdu \leq Pd min. - $\Delta 1$
		Pdu - Pdu \leq $\Delta 2$

Note: When the set point (max. or min.) falls between the lowest and lowest pt. possible, the precision may pass into a superior range (example AG 2.5 \rightarrow AG 5). If the pt. value is too close to that of the Pd, the option RJGI tripping is recommended (consult factory). In the case of two safety manometric boxes (BMS) both boxes should have a PSD > to the highest Pdo.

SELECTION OF BMS AND SPRINGS

Chose the type of safety manometric box (BMS) according to: PMS, the type of releasing precision

Choice of springs:

- Max. only or min. only
Take the spring with the highest point directly superior to the releasing pressure required.
- Max. and min.
Take the spring with the highest maximum point superior to the maximum releasing pressure required or with the lowest point inferior to the minimum tripping pressure required.

Table 19. Choice of BMS & Springs

PSD	Diaphragm	Bellows	Piston
0 - 20			
20 - 72		(*)	
72 - 100			
AG 2.5			
AG 5			
Max. only			
Min. only			
Max. & min.			

(*)Choice between piston (regular) and bellows (optional). Bellows are recommended if you require a small gap between releasing pressure, inlet pressure and exact precision. Pistons do not facilitate minimum and maximum releasing.

MATERIALS (BMS)

Table 20. BMS Material

	Diaphragm	Bellows	Piston
Spring case	Zinc pl steel		Stainless steel
Spring box	Aluminium + Chromatisation		
Diaphragm	Nitrile mesh		
Piston			Stainless steel
Bellows		Stainless steel	
Spring	Zinc pl steel		
Adjustment screw	Zinc pl steel		



WARNING

AUTHORIZED PERSONNEL ONLY

Risk of injury

After rearming, remove the reset key from the stem. Do not put fingers in or near the reset mechanism area.

ADJUSTMENT (BMS)

Generally speaking, adjustments are carried out with the slam shut valve closed. Only the detection stage is reset.

Control of the releasing value may be obtained by resetting the two stages.



CAUTION

Before any adjustment, check that the spring range installed corresponds to the required set point

BMS 1 (Figures 17 to 19)

RELEASING BY MAX. ONLY

- Adjusting the releasing screw
Free the min. hook (2).
Then in the following conditions:
 - no pressure in the safety manometric box (BMS),
 - set-point spring compressed so that the distance between the releasing screw and the pin D1 no longer increases, adjust the releasing screw (1) to $X = 1.5 \text{ mm}$ (detection stage set).
Jam nut (3).
- Adjusting the max. only releasing pressure
Admit the releasing pressure to P_{do} .
Screw the adjustment screw (5) until detection stage can be set.
Unscrew the adjustment screw (5) until detection stage release.
Check the pressure value at the releasing point (adjust if necessary).
Jam nut (4).

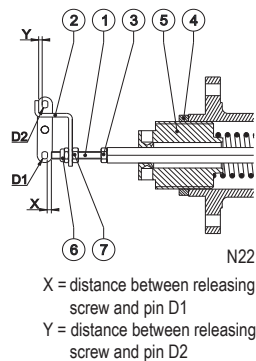

RELEASING BY MIN. ONLY

- Adjusting the releasing screw and hook
Free the min. hook (2).
Then in the following conditions:
 - set-point spring decompressed (adjustment screw (5) unscrewed),
 - pressure equal to the releasing pressure required for $P_{d \text{ min}}$ in the BMS,
 adjust the releasing screw (1) to $X = 2 \text{ mm}$ (detection stage set).
Jam nut (3).
Put the hook (2) into position and adjust $Y = 1.5 \text{ mm}$ with nuts (6) and (7).
Jam nuts (6) and (7).
- Adjusting the min. only releasing pressure
Continue admitting the required releasing pressure.
Screw the adjustment screw (5) until detection stage release.

Check the pressure value at the releasing point (adjust if necessary).
Jam lock nut (4).

RELEASING BY MAX. AND MIN. (diaphragm or bellows only)

- Adjusting the releasing screw
Free the min. hook (2).
Then in the following conditions:
 - set-point spring decompressed (adjustment screw (5) unscrewed),
 - pressure equal to the max. releasing pressure required in the BMS,
 adjust the releasing screw (1) to $X = 0 \text{ mm}$ (detection stage set).
Release manually.
Unscrew the releasing screw (1) 2 turns, which represents a distance of approximately 1.5 mm .
Jam nut (3).
- Max. adjustment
Same procedure as paragraph "Adjusting max. only releasing pressure".
- Min. adjustment
Admit an average pressure between max. and min., (for example: regulator set-point pressure).
Set the slam shut.
Admit a pressure equal to the min. $P_{d \text{ min}}$ releasing pressure required.
Adjust the hook (2) by progressively moving nuts (6) and (7) until it releases.
Jam nuts (6) and (7).
Check the pressure value at the releasing point (adjust if necessary).

BMS 2 with 1 max. only BMS 1

RELEASING BY MAX. ONLY

- Adjusting the max. push button
Remove the hook (2).
Then in the following conditions:
 - no pressure in the BMS,
 - set-point spring compressed so that the distance between the push button (1) and the pin D2 no longer increases, adjust the push button (1) to $X = 1.5 \text{ mm}$ (detection stage set).
Jam nut (3).

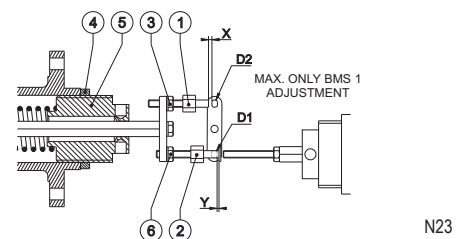

- Adjusting the max. only releasing pressure
Same procedure as paragraph "Adjusting the max. only releasing pressure".

RELEASING BY MIN. ONLY

- Adjusting the min. only hook
Remove the max. push button (1) or screw it tight to neutralize it.
Jam nut (3).

Type OS2

RELEASING BY MIN. ONLY (CONTINUED)

Then in the following conditions:

- set-point spring decompressed (adjustment screw (5) unscrewed),
- pressure equal to releasing pressure required in the BMS, adjust the min. hook (2) to $Y = 1.5$ mm (detection stage set). Jam nut (6).

- Adjusting min. only releasing pressure
Same procedure as paragraph "Adjusting max. only releasing pressure".

RELEASING BY MAX. AND MIN.

- Adjusting the push button
The min. hook (2) is completely unscrewed.
Then in the following conditions:
 - set-point spring decompressed (adjustment screw (5) unscrewed),
 - pressure equal to the max. releasing pressure required in the BMS.adjust the push button (1) to $X = 0$ mm (detection stage set).
Release manually.
Unscrew the push button (1) 2 turns, which represents a distance of approximately 1.5 mm.
Jam nut (3).
- Adjusting the releasing pressure to max. and min.
Max. adjustment
Same procedure as paragraph "Adjusting the max. only releasing pressure".
Min. adjustment
Admit an average pressure between max. and min., (for example regulator set-point pressure).
Set the detection stage.
Admit a pressure equal to the min. releasing pressure required.
Screw the hook (2) progressively until detection stage release.
Jam nut (6).
Check the pressure value at the releasing point (adjust if necessary).

MAINTENANCE (BMS)

- Control
 - Slam shut releasing (twice yearly)
 - External tight shut
 - Impulse part (diaphragm, bellows or piston)
- Disassembly
 - Unscrew the connector from the sensing line
 - Remove the safety manometric box (BMS)
 - Unscrew the blocking nut on the adjustment screw (manually)
 - Unscrew the adjustment screw (resetting tool)
 - Remove the hook or plate, depending on the type of BMS 1 or 2, from the detection rod (flat spanner 7)
 - Remove the upper case
 - BMS 162 (flat spanner 11)
 - BMS 071 (flat spanner 8)
 - BMS piston 27/17 (key 5)
 - BMS bellows 236/315 (key 5)
 - Disassemble the set plate/counter plate (Flat spanner 17 and pliers)
or
 - Remove the bellows or piston and guide (manually)
- Assembly
 - Proceed in reverse order to disassembly
- BMS torque values
 - Upper spring case/manometric box
 - BMS 162: 8 N.m
 - BMS 071: 5 N.m
 - BMS piston 27/17: 6 N.m
 - BMS bellows 236/315: 6 N.m
 - BMS 162 and 071 nut/diaphragm plate: 20 N.m

Emerson Process Management Natural Gas Technologies

Francel SA
Z.A. La Croix Saint Mathieu
28320 Gallardon, France
Tel : +33 (0)2 37 33 47 00
Fax : +33 (0)2 37 31 46 56

For further information visit www.emersonprocess.com/regulators

The Emerson logo is a trademark and service mark of Emerson Electric Co. All other marks are the property of their prospective owners. Francel is a mark of Francel S.A., a business of Emerson Process Management.

The contents of this publication are presented for informational purposes only, and while every effort has been made to ensure their accuracy, they are not to be construed as warranties or guarantees, express or implied, regarding the products or services described herein or their use or applicability. We reserve the right to modify or improve the designs or specifications of such products at any time without notice.

Emerson Process Management does not assume responsibility for the selection, use or maintenance of any product. Responsibility for proper selection, use and maintenance of any Emerson Process Management product remains solely with the purchaser.