

Severe Service Journal

A Publication of the Severe Service Team at Fisher Controls

Volume 2 Issue 4

December 2002

RESEARCH • PRODUCTS • NEWS • STEAM CONDITIONING

NotchFlo™ DST SOLVING DIFFICULT APPLICATIONS

The Severe Service Team at Fisher Controls recently released the new NotchFlo DST (Figure 1) for use in cavitating applications within the power generation industry, in oilfield production use and in refinery recirculation and letdown services. Since the release, the NotchFlo DST has proven successful at solving a number of difficult applications.

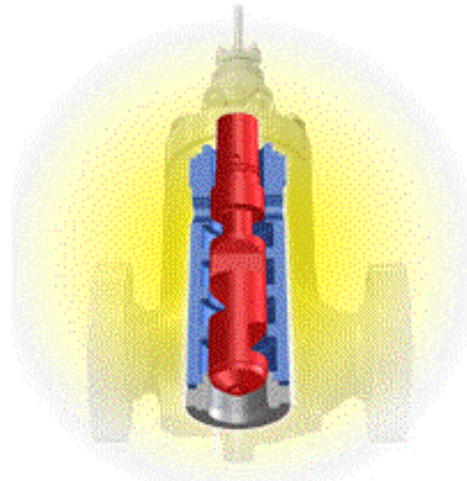

Figure 1: Fisher NotchFlo™ DST Dirty Service Trim

One of the first difficult applications tackled was found in an ethylene plant in the gulf coast region. The plant traditionally sent high-pressure ethylene and propylene to flare during startup or when an upset condition occurred. In order to reduce the volume of product sent to flare and saving money on excess emissions as well as lost product, the plant turned to NotchFlo DST to recirculate a portion of the process flow during these conditions.

These valves are required to handle 1300 to 1500 psig of cavitating fluid with entrained solids. This is accomplished by utilizing a series of pressure staging notches thus avoiding conditions that can cause cavitation and resultant trim damage.

Since these valves are required to operate only two or three times a year, long lasting tight shutoff is critical. With a protected seating surface and ANSI Class V seat loads, shutoff is not an issue with NotchFlo DST.

Because of the success that the plant has had in this service, they have since standardized on NotchFlo DST for all of their ethylene units.

Another recent success occurred at an Alberta power plant that was having repeated issues with their feedpump recirculation valves. The valves in question did not utilize any method of staged pressure reduction, thus exposing the valves to the effects of damaging cavitation. Because of the continued damage experienced, the plant was forced to keep a large number of valve plugs on the shelf to be changed out in three-month intervals.

Not only did the valve plugs experience severe cavitation and erosion damage, the resultant leakage and repeated maintenance intervals had a sizable impact on the efficiency and availability of the unit.

The plant is now in the process of upgrading three additional units with the NotchFlo DST solution.

Not only does NotchFlo DST alleviate issues with cavitation, plugging and leakage, it is pressure balanced to yield smoother operation while minimizing actuation requirements. NACE compliant materials are available in corrosive applications.

The NotchFlo DST is available in a variety of sizes, configurations and pressure classes. Visit www.fisher.com/products/severeservice for more information.

FISHER RECEIVES \$2M ORDER FOR TURBINE BYPASS EQUIPMENT

Fisher Controls recently received an order from a large engineering and construction firm for turbine bypass equipment to be utilized in two major power plants being constructed in Europe. Both projects have stringent noise requirements that require the latest in noise abatement prediction and abatement.

One of these projects utilizes an air cooled condenser, which can present a variety of challenges when incorporating a turbine bypass system. The bypass system is critical to plant operation by allowing the boiler and condenser to remain online during turbine trips and during startups.

Because of the high pressure drops and large flow rates seen in these applications, the generation of noise is of utmost concern. Also of concern is the amount of

area

taken up by the bypass system in the condenser duct. The size of the equipment inserted into the condenser duct can have a dramatic impact on the performance of the steam turbine.

Because of the stringent far-field noise requirements, the customer's engineers worked closely with Fisher's acoustics experts to establish a system noise level that was not only acceptable, but also achievable. Many demonstrations were shown to understand Fisher's research and understanding of these applications.

One demonstration shows the differences in noise abatement technologies currently available. The laser shadowgraph display shows the importance of jet separation in noise abatement trims while also allowing the audience to actually hear the difference in noise levels being emitted by different types of noise abatement trims.

Another demonstration conducted showcased a common configuration of a sparger inserted into a condenser duct. Fisher 2 shows the sparger/duct testing apparatus at the Marshalltown Research Facility.



Figure 2: Duct/Sparger Testing Arrangement

This apparatus helps to optimize the placement, insertion length and spacing between the spargers within the duct. Spacing is of utmost importance given the forces that can be exerted on the duct if the spargers are spaced too closely together. Considering that most condenser ducts are no more than $\frac{3}{4}$ " thick, any excessive forces can lead to additional noise generation and damage to the duct and supporting structures.

To properly account for these effects, pressure and strain measurements are taken at various points upstream, downstream and around the entire

circumference of the duct to properly understand the impact on the system.

After seeing the demonstrations and research conducted, the customer felt that Fisher had the best solution to offer in terms of both noise prediction and noise abatement.

The solution consisted of two 12x24 and two 26x36 Fisher CON-TEK valves that incorporate the proven WhisperFlo (Figure 3) noise abatement technology along with numerous other large, high pressure valves. Also included in the package were WhisperFlo spargers to be inserted in the condenser duct that will help to provide the total noise abatement solution.

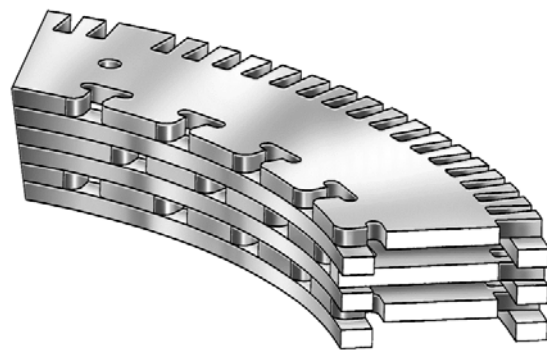

Figure 3: WhisperFlo Noise Abatement Trim

WhisperFlo is a multi-path, multi-stage noise abatement technology that can reduce noise by up to 40 dBA, surpassing conventional noise trims 10 dBA.

Fisher Controls has dedicated itself to providing system based noise prediction tools to ensure that plants will not experience noise related issues after installation. The research conducted and developed tools provide the user with the comfort and satisfaction that their valve systems will perform to the required specifications.