

FISHER IN CONTROL

CORPORATE NEWS

Emerson congratulates Qatargas on the inauguration of Qatargas 2 project

Emerson Process Management technology and service supports Qatargas 2 to boost LNG production and meet world demand for clean, reliable energy

DOHA, QATAR – Emerson Process Management business congratulated Qatargas Operating Company Ltd. on the inauguration of the world's largest facility for producing liquefied natural gas (LNG) in the Ras Laffan Industrial City. The inauguration was in April 2009.

Qatargas selected Emerson to be the main instrumentation and controls contractor for the Qatargas 2 project. Emerson is supplying its world-class digital automation technologies to help make LNG production in each mega train as efficient, safe, and cost-effective as possible. Emerson has also been making significant investments in Qatar, where it has a long-term agreement as the preferred supplier of automation technologies and services to Qatargas, one of the world's leading producers of liquefied natural gas (LNG).

Qatargas and Emerson signed an alliance agreement in 2007 with the challenge to aggressively expand its facilities to boost LNG production to 42 million tons annually by the end of the decade. To meet this ambitious goal, Qatargas is constructing production facilities on a scale that's never been built before – and Emerson's digital automation technologies play a vital role in the operations of each mega train.

For this project, Qatargas accessed Emerson's global network of experts and manufacturing capabilities during the project implementation. Thousands of Emerson personnel on three continents (Europe, North America, and Asia) have been involved in developing the process management technologies, devices, and software programming to support the Qatargas 2 project. Emerson engineers are also providing asset management services, advanced skills training, and a comprehensive parts management program.

“What Qatargas has achieved is truly remarkable and is unprecedented in its size and scope, featuring significant new, game-changing technologies to achieve massive economies of scale,” said Emerson Process Management Chairman John Berra. “The inauguration of Qatargas 2 marks a historic milestone for the LNG industry and Qatar's leadership in the LNG world.”



Emerson announces WirelessHART™ Fisher® position monitor, extends safety and performance gains from Smart Wireless solutions

Innovative wireless and linkage-less monitor delivers previously unavailable equipment position data to improve plant performance and safety

Emerson Process Management announces expansion of its Smart Wireless solutions family with the release of the Fisher® [4320 wireless position monitor](#). Beyond its wireless advantages, the 4320 monitor is the first and only linkage-less device to provide accurate position feedback. The 4320 monitor uses industry standard WirelessHART™ communications.

Most process plants have hundreds, or even thousands, of valves that are not connected to the control system because of high wiring costs. These valves currently provide no feedback on their actual positions, even though incorrectly positioned valves represent a significant cause of safety-related incidents. Unfortunately, users have typically not been able to access the position data that is valuable to the performance and safety of their plant.

The Fisher 4320 wireless position monitor changes the economics since it represents only 10% to 20% of the installed cost of a wired solution. The wireless monitor installs and commissions quickly, providing users with a cost-effective way to access the information.

The 4320 wireless position monitor is part of Emerson's broad range of intelligent, digital field devices that power the PlantWeb® architecture to improve plant efficiency by 2% and more through delivering asset optimization, process automation, and management execution. Like other devices in the Emerson Smart Wireless family, the 4320 position monitor has secure and reliable performance. The position monitor has a 5- to 10- year SmartPower™ battery life and is fully compatible with existing Smart Wireless networks.

Emerson's Smart Wireless solution is an extension of the PlantWeb digital plant architecture, combining highly reliable, smart monitoring devices with wireless transmitters in an innovative self-organizing mesh network that automatically adapts as device points are added or removed, or obstructions encountered.

For additional information on the Fisher 4320 wireless position monitor, see the brief [4300-series wireless position monitor video](#) at http://www.emersonprocess.com/videos/TechDemos_Wireless.asp, or go to www.emersonprocess.com/Fisher, or contact the nearest Fisher sales office.





Emerson has the expertise and experience to handle your instruments and control valve maintenance and repair, regardless of your industry.

The way you manage your key production assets – including the instruments and valves in your process – directly affects your facility’s availability and profitability. The health and performance of your assets can determine your success. Emerson’s unique approach to Asset Optimization will help you reach your business goals.

Emerson’s Instrument & Valve Services experts give you experienced professionals where you need them, when you need them. We’ll help you build reliability programs to help your plant achieve maximum capacity and minimal risk of downtime.

Wherever you are in your plant’s life cycle – startup, maximizing operation turnaround/ outage, or life extension – healthy assets are the way to a healthier bottom line. With Emerson as your partner, you’ll be on the path to realize the true potential of your instruments and valves.

Check out the Emerson home site for more information: www.emersonprocess.com/Fisher.

Emerson introduces the new Fisher® FIELDVUE™ DVC6200



Introducing the latest addition to the FIELDVUE™ family of smart digital valve controllers, the DVC6200 is a linkageless and contactless smart positioner which utilizes field proven non contact technology that has been in use since 2004.

The new DVC6200 mitigates the risk of failure due to adverse operating conditions such as high vibration, corrosion and cycling with fewer feedback parts. It can also measure the actual valve stem travel and no crossover adjustment is necessary.

The Fieldbus version of DVC6200 has Back-up LAS (Link Active Scheduler) and faster function blocks hence enabling more loops per segment.

The two housing configurations: GX valve and all others (linear or rotary valve) reduce inventory and minimize confusion associated with multiple housing types. Initial release of the DVC6200 HART and Foundation™ Fieldbus version are adaptable to all actuator mountings for Rotary and Sliding Stem (up to 24 inch) on both Fisher and non-Fisher actuators. The DVC6200 will be available for ordering in December 2009.

Emerson releases Fisher® ValveLink™ Mobile

Emerson is pleased to announce the release of the Fisher ValveLink Mobile software.

ValveLink is a valve diagnostics software used in conjunction with the Fisher FIELDVUE digital valve controller to detect common valve issues like valve seat/plug wear, wearing of valve packing and actuator/tubing air leakage. It is easy to use, has great graphical representation and is best-in-class as a diagnostic tool for valves. However, it is not always possible to carry a notebook to the hazardous areas in the plant, hence the valve diagnostics might have to be done remotely from the control room or maintenance workshop. With the Fisher ValveLink Mobile, valve troubleshooting can now be done in-field, next to the valve.

The following are the benefits for users:

- ValveLink Mobile runs on 375 or 475 Field Communicator. Since the Field Communicators are intrinsically safe approved, this allows the ValveLink Mobile software to be used for troubleshooting valve problems in the field.
- An added advantage is that it can also run on any PDA or Smart Phone using Windows Mobile OS v5 or higher with Bluetooth HART® modem. This is a convenient tool to use in the workshop for configuration, calibration and troubleshooting or in areas where no hazardous approval is required.

ValveLink Mobile comes **FREE** of charge with the new purchase of 475. It is also free of charge for existing users with the Easy Upgrade option for their Field Communicator. For the 375, a minimum of 512 Mb memory card is needed.

The following are the highlights of the ValveLink Mobile:

- Easy to use, good colour contrast and large icons which can be driven by a thumb or stylus.
- Determine valve stroking time.
- Pre-set step response tests (1) 25% Step Study, (2) Large Step Study and (3) Small Step Study for determining the dynamic response of the control valves.
- Total Scan (Valve Signature, Dynamic Error Band and Drive Signal) plots in real time.
- Diagnostic graphs are displayed in real time, can be zoomed and axes can be changed on the fly.
- Datasets are automatically saved after each test.
- Saved information in ValveLink Mobile can be transferred to a computer running ValveLink Solo, SNAP-ON, or PLUG-IN for further analysis or archiving.



Emerson has it: Topworx® 4310 wireless solution for tank storage

TOPWORX

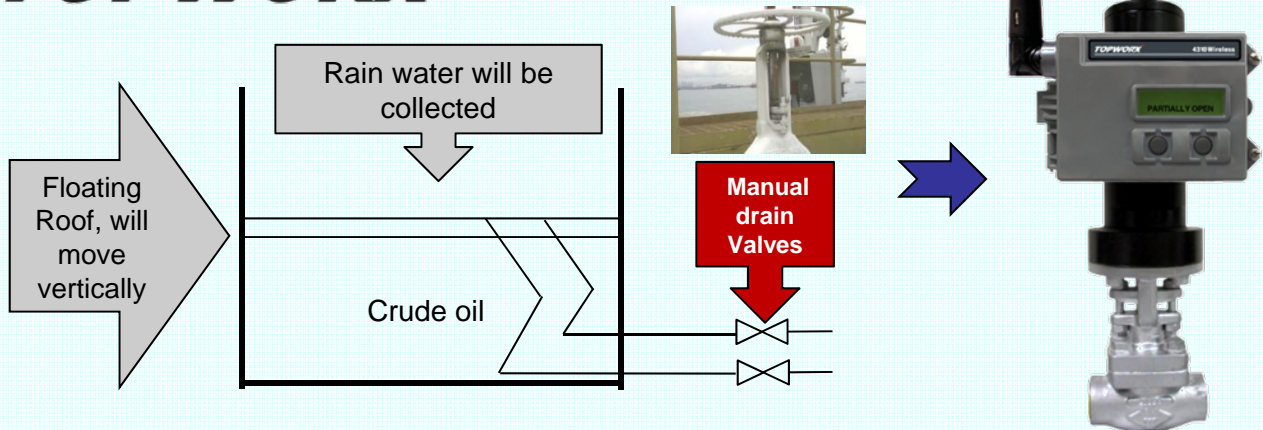

Manual Gate valves are commonly used for Floating Roof Storage Tank in Tank Farms

➤ **Customer Pain Points**

- Unable to monitor position of the drain valves
- If water is not drained, the roof would collapse
- Currently, manual labor is used to drain off the rain water collected

Solution

TopWorx® 4310 with integrated gearbox, no limitation to valve travel.

Benefits

- Provide feedback on valve position and trending of frequency of use with time stamp for safety or monitoring purpose.
- Able to monitor a valve position and technicians are able to schedule the opening and closing of valves when required, thus reducing the need for site walks.
- Provide status feedback on the local display of 4310.

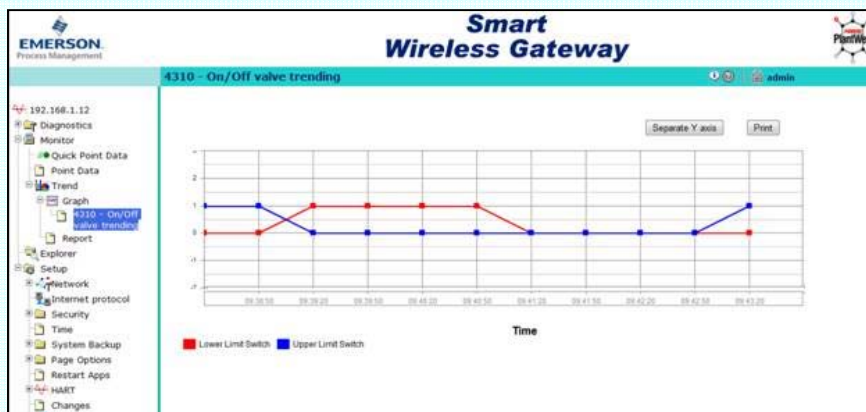

Fisher® Whisper Trim™ III eliminates vibration in Rich Amine Letdown applications

APPLICATION

Rich amine letdown valve.

CUSTOMER

A gas processing plant in Thailand.

THE CHALLENGE

The most widely used process to remove acid gases in the gas processing unit is the Alkanolamine process, commonly referred as amine unit. This is a continuous operation where amine solution is used to extract acid gases from the production stream at high pressure in the absorber tower. The acid-gas-rich amine (rich amine) leaves the bottom of absorber through a rich amine letdown valve and is sent to a flash drum.

This is a demanding application as rich amine contains entrained gas. Due to the high pressure differential across the rich amine letdown valve, out-gassing takes place at the valve trim. Due to the turbulent two-phase fluid and large amount of gases liberated at the valve trim, severe vibration in the letdown valve was occurring. The vibration was so severe that it caused the valve stem to break. Seeking a solution, personnel at the processing plant contacted Emerson Process Management, Asia Pacific to uncover the root cause of the problem and propose a control valve that would address the vibration problem.

THE SOLUTION

Engineers at Emerson Process Management, Asia Pacific, evaluated the application and recommended replacing the existing valve with a Fisher 6" x 4" EWT body control valve using Whisper Trim III in a flowup configuration. Whisper Trim III utilizes specifically designed, drilled-hole passages to control the rapid fluid expansion experienced in this type of service. The noise and vibration potential is further controlled by a valve body designed to limit high velocity flow at the valve outlet. These specific trim and body technologies together allow the valve to provide its main function, controlling the level in the amine contactor, without the system vibration typically generated by a standard valve. The new Fisher valve with Whisper Trim III was installed and the severe vibration and valve stem breakage were eliminated. For more information on severe service solutions, see us at www.fishersevereservice.com.



Fisher® EW Series easy-e™ valves using Whisper Trim® III perform exceptionally well in noise and vibration abatement applications.

**A critical valve fails, the process shuts down,
and you get the call.**

Better luck tomorrow.

You can't afford a shutdown. Not today. Not tomorrow. Which means the critical valves in your plant must perform reliably day-in and day-out. It also means you need field-proven Fisher® control valve answers to tough flow control conditions.

Begin by contacting Emerson's valve application specialists who bring years of know-how to solving flow control problems. And then specify reliable, Fisher severe service valve answers to cavitation, excessive noise and vibration, and pressure drop extremes. Learn more by visiting www.FisherSevereService.com

FISHER

Severe Service

The Emerson logo is a trademark and service mark of Emerson Electric Co. © 2005 Fisher Controls International LLC



EMERSON
Process Management

EMERSON. CONSIDER IT SOLVED.

Emerson achieves one million unit sales in Fisher® FIELDVUE™ instruments



A proud and glorious moment. The Fisher Instruments group has hit a million unit milestone-sales of FIELDVUE® instruments. The Asia-Pacific has seen unprecedented growth in FIELDVUE digital valve Controllers sales, maintaining 14 consecutive years of continuous growth.

Introduced in 1994, the multiple award winning microprocessor-based FIELDVUE digital valve controller (DVC) has helped thousands of customers realize the benefits of predictive maintenance through on-line and off-line valve assembly diagnostics. This has greatly contributed to plant availability and throughputs while reducing process variability and extending the time between shutdowns.

Alfred Lee, Director of Asia Pacific Instruments Business Unit, said that the FIELDVUE instruments' renowned accuracy and diagnostic capabilities have revolutionized the process control industry's approach to tighter process control and maintenance. "Achieving the one million units of FIELDVUE instrument sales is truly an industry milestone. Fisher was among the first to introduce the intelligent positioner and it is heartening to observe that it has now become an industry standard", he added.

The full value of FIELDVUE instruments diagnostics is realized when used in conjunction with AMS Intelligent Device Manager and ValveLink™ software.

The FIELDVUE range of products include stainless-steel construction, remote mount, and extreme-temperature, low bleed, gas certified, nuclear, SIS and ODV options. Two new products, the ValveLink™ Mobile and DVC6200 (HART® and FOUNDATION fieldbus) series were introduced in November and December 2009 respectively.

Emerson gears up during economic slack with Performance Without Compromise seminars for customers



Despite a challenging year in 2009, Emerson stepped up its market leadership endeavours and conducted a series of customer-oriented seminars called **Performance Without Compromise (PWoC)** in several Asia-Pacific countries - India, China, **South Korea**, Malaysia, and Australia.

The seminars are a fusion of presentations, information sessions and application displays. Presentations that were delivered focused on solving customer problems with all Emerson products and technologies. So far, more than 1,200 customers have attended the events.

Beijing China



Brisbane Australia

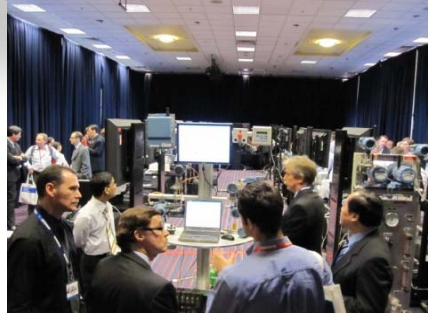

Seoul, South Korea



Kuala Lumpur Malaysia



Mumbai India





PETRONAS INSTRUMENT FORUM 2009

Sheraton Imperial Kuala Lumpur Hotel
1st ~ 2nd December 2009

In another separate customer event, Emerson was among the the successful candidates who were invited and shortlisted for participation in an exhibition that was organised in conjunction with the Petronas Instrument Forum 2009. The event was held at the Sheraton Imperial Kuala Lumpur Hotel on Dec ember 1st and 2nd 2009.

The products exhibited were the:

- Smart Wireless THUM Adapter
- Fisher Control Disk Rotary Valve
- GX 3-Way Valve & Actuator
- DVC 6200
- Wireless Gateway
- Topworx Fieldbus
- Topworx SIS

This forum, themed “Delivering Superior Plant Performance through Reliable Instruments” was a platform for the Instrumentation and Control fraternity of Petronas to share their best practices, lessons learnt along the way and technology applications of the business.



Fisher® Optimized Antisurge control valve technology takes centrestage at LNG conference and customer seminars in Perth



Emerson Process Management participated as a titanium sponsor in the 4th annual LNG conference in Perth on Aug 10-11, 2009. Three other customer seminars were jointly organised on Aug 12-13, 2009.

The theme for the entire 4-day event was on Fisher's pioneering capability in optimized antisurge control valve technology and how this could contribute to a plant's performance and reliability. The guest speaker, John Wilson, Director for Hydrocarbon Industry, hailed from the United States and is one of the leading experts on engineered products. John is also an author of several technical articles on the subject.

During the 2-day conference on Aug 10-11th, a presentation of Fisher's antisurge valves and a live demo were delivered to the conference participants and delegates. The same topics were further extended to 3 other customer-focused seminars after the conference on Aug 12-13th.

"I think these types of events are one of the best ways to show Fisher's capabilities in this application. The adage 'seeing is believing' rings true when discussing compressor antisurge valves. No set of power point slides or brochures can fully showcase our capabilities in severe service applications better than this", said John.

John Wilson:

I do feel that our capabilities are unmatched. This is due to our focus on understanding the specific application and developing products to meet the customer's needs.



Fisher® Control-Disk™ Valve

- ✓ **Excellent throttling control in the 15 to 70 percent travel range**
- ✓ **Meets API, ASME, and EN standards, making it suitable for use in all world areas**
- ✓ **Compact size meets limited space and piping requirements**

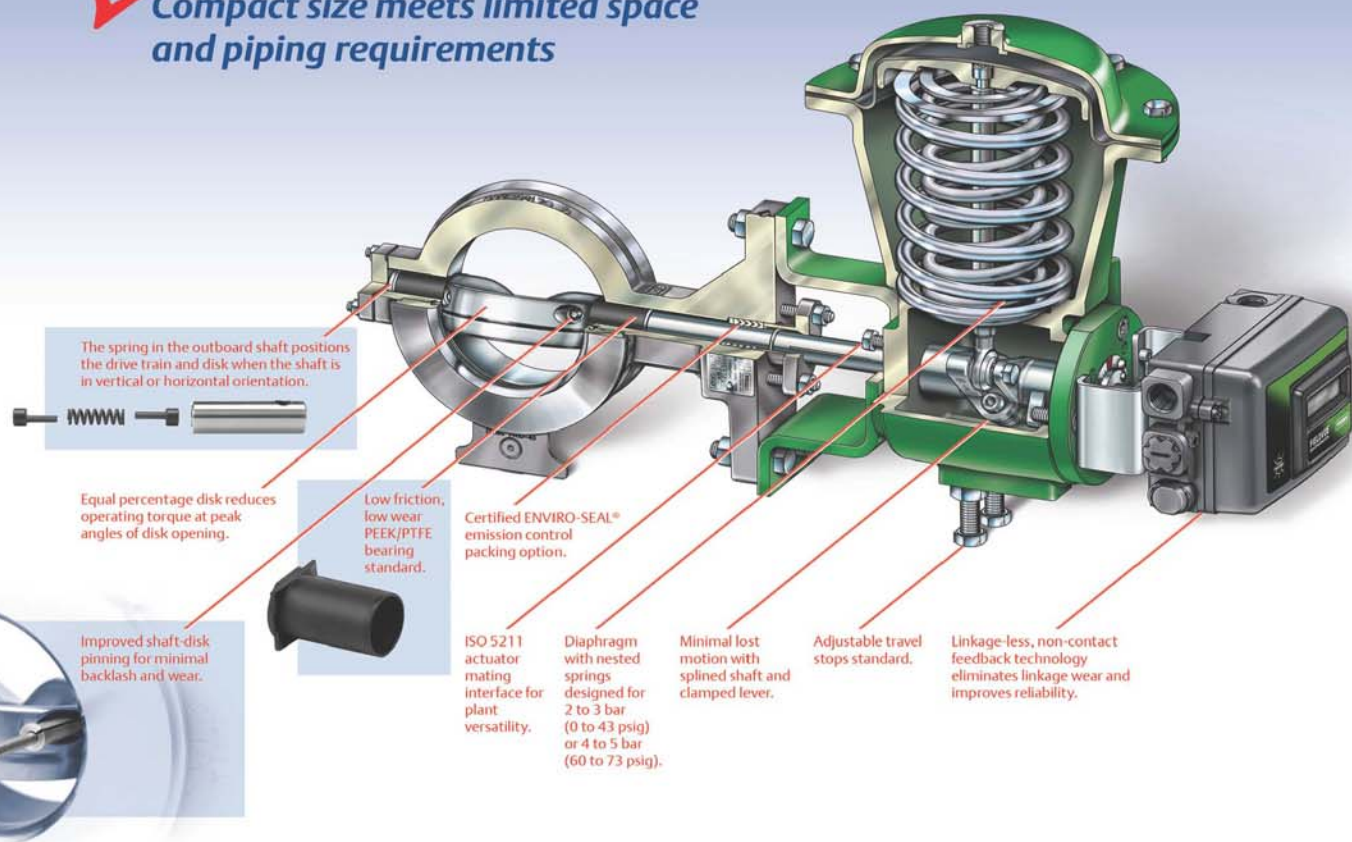

EMERSON. CONSIDER IT SOLVED.™