

# Bristol® Series 5453-40G

## Indicating Pneumatic Temperature Controllers/Transmitters

### General

The Bristol® Series 5453-40G control unit, is part of the Bristol 624-II family of pneumatic instruments from Emerson Process Management. It is designed for performance and durability under rigorous operating conditions. The body is of rugged, precision die cast aluminum, and all working parts are of stainless steel. Diaphragms are made of Neoprene; feedback bellows are Ni-Span-C.

### Features

Fast response and highly stable control action are key features of the 624-II controller. It is especially suitable for field-mounting and other types of installations where a control record is not required.

- Gain Control: 50-.25 or 100 2.5; easily adjustable
- Integral (Reset) model: Adjustable from less than .01 to 30 repeats per minute
- Derivative control: Action adjustable from 0 to 30 minutes (derivative by – pass standard)
- Easily reversible control action
- High capacity pilot: Flow is well over 3 scfm at 1 psi drop, both exhaust and delivery
- Push button restriction cleaner, standard
- No plastic tubing



### Specifications

- Case: Weatherproof, die-cast aluminum case with gasketed aluminum door and gray epoxy finish standard
- Case dimensions: 7 23/32" wide x 7 15/16" high. 2" horizontal and 5" vertical clearance required between adjacent panel mounted units.
- Panel cutout dimensions: 7 3/16" wide x 7 9/16" high. 2" horizontal and 5" vertical clearance required between adjacent panel mounted units.
- Mounting: Interchangeable flush or surface mounting. Optional brackets and U-clamps available for 2" pipe mounting.
- Scales: Segmental, 3 1/4" calibrated length. Black numerals on white background. Fluorescent pointers for measured variable and setpoint.
- Output: 3-15 psig standard. Other ranges available. Direct or reverse acting.
- Connections: Supply and output, 1/4" NPT female at bottom of case

- Measuring elements: Class 1 and class 3 thermal systems available for ranges between -350° and +1000°F
- Calibrated accuracy: +0.5% of span
- Control modes: Gain (proportional), gain + integral (reset), gain + integral + derivative (3-15 psig output)
- Mode adjustments:
  - Gain: 100-2.5 or 50-.25
  - Integral: .01 to 30 repeats per minute
  - Derivative time: 0 to 30 minutes
- Response level: 0.006% of span.
- Frequency response: Response curve flat to 400 cpm with gain control unit, to 300 cpm with gain + integral unit
- Pilot capacity: 3 scfm, exhaust or delivery, for 1 psi change in output pressure
- Air consumption: 0.05 scfm at balance with 20 psig air supply
- Temperature stability: ±1% of span change in output pressure per 100°F change in ambient temperature

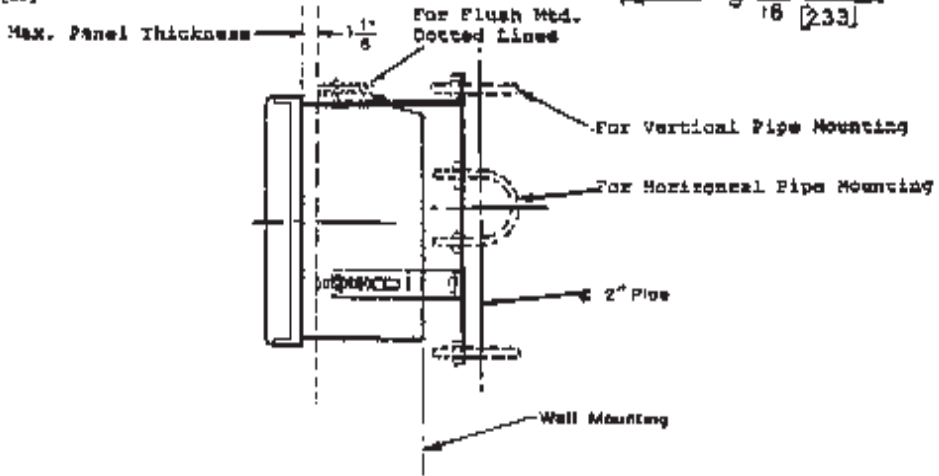
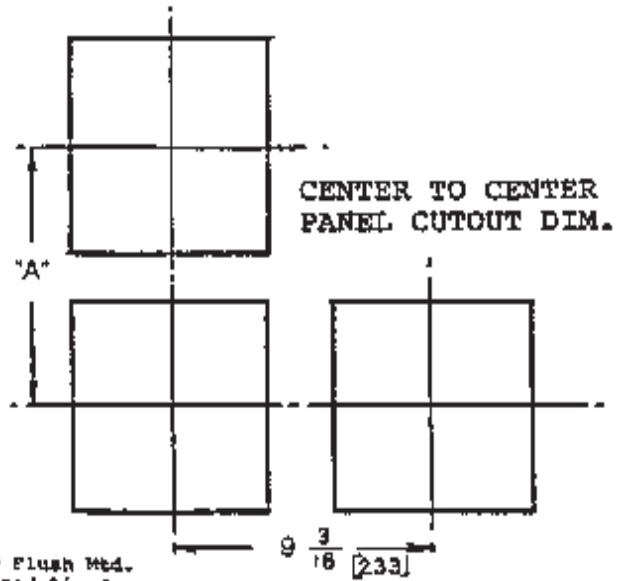
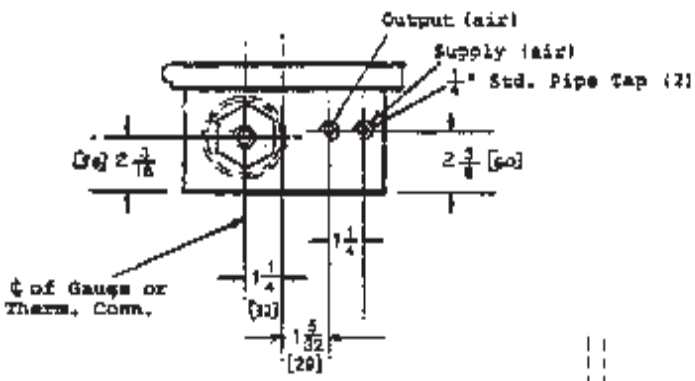
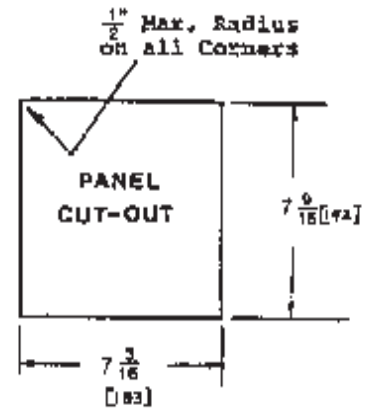
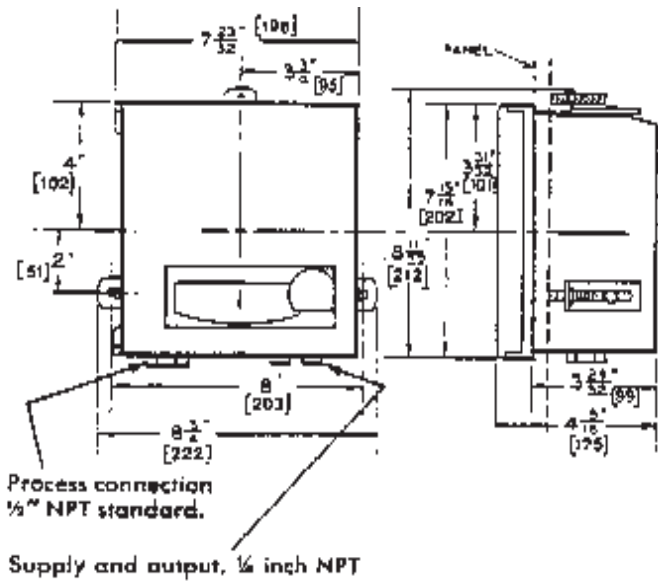

## 624-II Temperature Controllers Series 5453

Model No. 5453-40G A - B - C - D - E - F - G - H

5453-40G

SELECT	DESCRIPTION	CODE
	<b>BASIC</b>	
A	<b>ELEMENT TYPE</b> <span style="float: right;"><b>545340GBAS</b></span>	
10	Liquid Filled Projecting Bulb	0
	Liquid Filled, Fully Compensated Plain Bulb, CL 1A	1
	Liquid Filled, Case Compensated Plain Bulb, CL 1B	2
	Gas Filled, Case Compensated Plain Bulb, CL 3	4
B	<b>RANGE PROTECTION</b> <span style="float: right;"><b>XRANGE</b></span>	
20	None	0
	Overrange & Underrange	1
C	<b>CALIBRATION</b>	
30	Direct Standard	1
	Reverse Standard	2
	Direct Full Scale	3
	Reverse Full Scale	4
D	<b>CONTROL</b> <span style="float: right;"><b>X624CONTRL</b></span>	
40	20 PSI Supply, Gain only	1
	20 PSI Supply, Gain & Integral	2
	20 PSI Supply, 3 mode	3
	30 PSI Supply, Gain & Integral	4
	35 PSI Supply, Gain only	5
	35 PSI Supply, Gain & Intergral	6
	60 PSI Supply, Differential Gap	7
	20 PSI Supply, Transmitter	8
	30 PSI Supply, Transmitter	9
E	<b>EXTERNAL FEEDBACK</b> <span style="float: right;"><b>XEXFEED</b></span>	
50	Without	0
	With (20 PSI supply)	1
F	<b>PNEUMATIC SET POINT</b> <span style="float: right;"><b>X5453SP</b></span>	
60	Without	0
	With (3-15 PSI Set Point signal)	1

G	MANUAL - AUTOMATIC STATION	XMAN-AUTO
70	Without	0
	With (Not for model selection D7.)	1
H	MOUNTING	X500MOUNT
80	Wall	1
	Flush	2
	Pipe	3
<i>Note: 1</i>	<b>General Information:</b>	
	Each filled thermometer is supplied with a stainless steel bulb and 5 feet of stainless steel capillary.	
	For Code 0, Temperature span is 0-100 Deg F, specify <b>P/N 392817-01-2</b> .	
	Codes 1, 2 & 4 see <b>Thermometer price pages 2, 3 &amp; 4</b> . Make sure the thermal system model number is entered as the next line item.	
<b>Also Specify the scale &amp; range.</b>		

© 2007 Remote Automation Solutions, division of Emerson Process Management. All rights reserved.

Bristol, Inc., Bristol Babcock Ltd, Bristol Canada, BBI SA de CV and the Flow Computer Division, are wholly owned subsidiaries of Emerson Electric Co. doing business as Remote Automation Solutions ("RAS"), a division of Emerson Process Management. FloBoss, ROCLINK, Bristol, Bristol Babcock, ControlWave, TeleFlow and Helicoid are trademarks of RAS. AMS, PlantWeb and the PlantWeb logo are marks of Emerson Electric Co. The Emerson logo is a trademark and service mark of the Emerson Electric Co. All other marks are property of their respective owners.

The contents of this publication are presented for informational purposes only. While every effort has been made to ensure informational accuracy, they are not to be construed as warranties or guarantees, express or implied, regarding the products or services described herein or their use or applicability. RAS reserves the right to modify or improve the designs or specifications of such products at any time without notice. All sales are governed by RAS' terms and conditions which are available upon request. RAS does not assume responsibility for the selection, use or maintenance of any product. Responsibility for proper selection, use and maintenance of any RAS product remains solely with the purchaser and end-user.

**Emerson Process Management  
Remote Automation Solutions**

Watertown, CT 06795 USA T 1 (860) 945-2200  
 Mississauga, ON 06795 Canada T 1 (905) 362-0880  
 Worcester WR3 8YB UK T 44 (1) 905-856950

