

Product Data Sheet

PS-001343, Rev. B
January 2011

Micro Motion® 7829 Viscomaster® Viscosity Meter

Micro Motion® viscosity meters are built to tackle the most demanding process and marine applications. Rugged and reliable direct insertion meters with very low maintenance, they provide fully integrated “fit and forget” viscosity measurement.



High accuracy viscosity measurement

- Multi-variable measurement of viscosity, density and temperature
- Unique direct insertion design
- Integral-mount transmitter with analog and digital communications

Greatest installation flexibility

- Continuous, real-time measurement in various installation configurations
- Retrofit kits available for easy replacement of existing viscosity meter technologies

Superior reliability and safety

- Worldwide marine-approved design for aggressive environments
- Insensitive to vibration, temperature, and pressure variations

7827 High performance viscosity sensor

7829 Visconic High performance industrial HFO viscosity meter

7829 Viscomaster High performance marine and power HFO viscosity meter

7827 / 7829 High performance viscosity meter kits

Micro Motion® 7829 Series Viscomaster® Viscosity Meter

About the 7829 Viscomaster

The Micro Motion® 7829 Viscomaster is a proven technology for the accurate, continuous real-time measurement and control of liquid viscosity. The 7829 Viscomaster viscosity meter has been designed for installation in fuel oil applications that supply engines, turbines, and burners in on-shore and off-shore applications.

As part of its unique and rugged design, the 7829 Viscomaster viscosity meter directly measures both dynamic viscosity and density, allowing a true measurement of kinematic viscosity, which is the preferred parameter in many industries. The Viscomaster can easily cope with a range of fuels from heavy fuel oil (HFO) to marine gas oil (MGO).

The Viscomaster has worldwide marine-industry approvals including Lloyds Register, GL, DNV, ABS, and BV. For a complete list of marine approvals, see “Marine approval classifications” on page 7.

Advantages

- Fully integrated “fit and forget” digital viscosity and temperature measurement for monitoring and control
- Two direct 4–20 mA outputs of viscosity, base viscosity, density, base density, or special calculations (CII, CCAI, % solids, °API, specific gravity)
- Modbus/RS-485 communications
- Continuous measurement
- No moving parts means virtually no maintenance
- PFA-coated tines for asphaltene rich fuels
- Integral Class B PT100 temperature sensor
- Hazardous-area approved (ATEX and CSA)
- Insensitive to vibration
- Direct insertion meter suitable for high-line pressure
- PC configuration tools for diagnostics and data logging

Contents

Typical applications	3	General classifications	7
Typical industries	3	Materials of construction	8
Principle of operation	3	Weight	8
Features	4	Electrical	8
Performance	6	Dimensions	9
Temperature specification	6	Installation	10
Pressure ratings	6	Ordering Information	11
Hazardous area classifications	7		
Marine approval classifications	7		

Typical applications

- Heavy fuel oil (HFO) heater control to burners and engines
- Lube oil viscosity control

Typical industries

- Marine
- Power
- Heavy fuel oil (HFO) blending and bunkering

Principle of operation

The 7829 Viscomaster viscosity meter uses a vibrating fork technology to measure density and viscosity. As the liquid density changes, it affects the vibrating mass of the meter. The change in vibrating mass then affects the resonant frequency. Viscosity is a function of the bandwidth, which is an indication of the damping associated with the liquid.

The following figure illustrates how the 7829 meter uses the resonant frequencies at point A (the lower -3 db point) and at point B (the upper -3 db point) to digitally calculate the density, bandwidth and quality factor. These measurements then give digitally determined values of fluid density and viscosity.

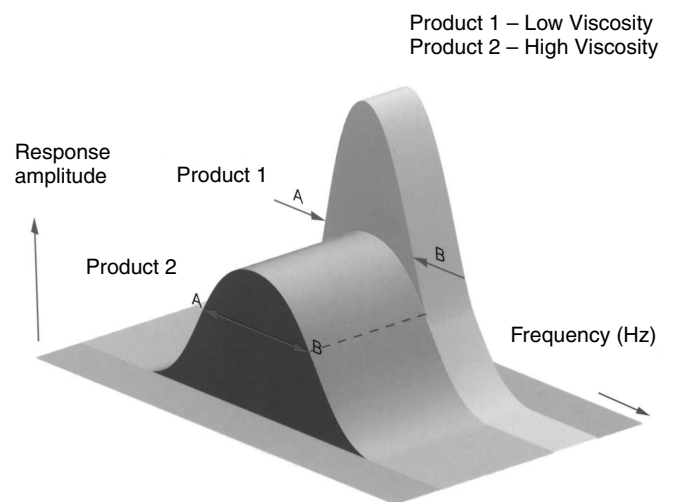

$$\text{Bandwidth} = \text{Point B} - \text{Point A}$$
$$\text{Resonant Frequency} = (\text{Point A} + \text{Point B}) / 2$$
$$\text{Quality Factor} = \text{Resonant Frequency} / \text{Bandwidth}$$

Features

The Viscomaster offers features that are suited to specific applications and industry needs.

Process Requirement	7829 Viscomaster
Dynamic viscosity	✓
Kinematic viscosity	✓
Temperature measurement	✓
Integrated density measurement	✓
Referred kinematic viscosity	✓
Referred density measurement	✓
Sensor type	Fork
Mounting arrangement	Bypass / Inline
Transmitter version	✓
mA outputs	Two 4–20 mA (both configurable)
Measurable liquid types	Heavy fuel oil
Principle markets	Marine / Power

No Field Calibration Required

The 7829 Viscomaster viscosity meter is factory-calibrated and no field calibration is required. The calibration is traceable to UK National Standards through the Micro Motion onsite accredited laboratory.

Integral Electronics for Signal Processing

A configured microprocessor-based electronic module provides the full signal conditioning, calculation, and diagnostic facilities within these meters. The 7829 Viscomaster does not require remote electronics for signal processing. This meter simultaneously measures real-time viscosity, density, and temperature. The integrally mounted electronics can be configured to output a number of user-defined parameters.

RS-485/Modbus Communications Interface

All measurements are available digitally through the built-in RS-485/Modbus communications interface, for integration into plant data systems. You can use the ADView or ProLink II (v2,9 or later) software tools to configure or diagnose a meter via the RS-485/Modbus interface. See “ADView Software Tool Features” and “ProLink II Software Tool Features” for more information.

User-Configurable 4–20 mA Outputs

Two 4–20 mA outputs are available and configurable to output parameters such as dynamic and kinematic viscosity, density, temperature and other calculated measurements such as base viscosity, °API, and specific gravity.

Any of the output parameters can be used to drive the two 4–20 mA outputs, enabling them to be used as the process variable in control applications without the need for additional processing electronics.

Following are the default settings of the two 4–20 mA outputs.

Code	mA output 1		mA output 2	
	Viscosity (cSt)		Temp (°C)	
	4 mA	20 mA	4 mA	20 mA
H	0	25	0	150
J	0	50	0	150
E	0	100	0	150
Z	Custom			

Low Maintenance Required

Because the 7829 Viscomaster viscosity meter has no moving parts, minimal maintenance is required, leading to lower overall operating costs. The vibrating forks are supplied with PFA coating to assist self-cleaning. PFA is ideal for hydrocarbon and fuel oil applications.

ADView Software Tool Features

ADView is a PC-based configuration and diagnostics tool that runs on a Microsoft® Windows® platform, communicates with the meter through a standard serial port, and provides the following functionality:

- Setting up a serial link to communicate with the 7829 transmitter
- Configuring the 7829 transmitter
- Displaying data real-time or as a graph
- Logging data to a file
- Verifying correct operation of the system and diagnosing faults

ProLink II Software Tool Features

The ProLink II software tool (v2,9 or later) can be used with the meter. ProLink II runs on a Microsoft Windows platform, communicates with the meter through a standard serial port or USB port, and provides the following functionality:

- Configuring the 7829 transmitter
- Viewing and logging process parameters
- Viewing meter diagnostics

Performance

Viscosity Calibrated Range	0,5 to 100 cP
Viscosity Accuracy	±1% span (±0,2 cP up to 10 cP)
Viscosity Repeatability	±0,5% of reading
Density Calibrated Range	0,6 to 1,25 g/cc
Density Accuracy	±0,001 g/cc
Density Repeatability	±0,0001 g/cc

Temperature specification

Process	-40 °C to +200 °C
Ambient	-40 °C to +85 °C

Integral temperature sensor:

Technology	100 Ohms RTD (4 wire)
Accuracy	PT100 BS1904 Class B, DIN 43760 Class B

Pressure ratings

Maximum operating pressure⁽¹⁾	207 bar
Test pressure	Tested to 1,5 x the maximum operating pressure
PED compliance	Outside the scope of European directive 97/23/EC on Pressure Equipment.

(1) Actual maximum operating pressures are limited by the process connection rating.

Hazardous area classifications

ATEX

ATEX-approved: Certification for use in Europe

ATEX II2G Ex d IIC, T4

CSA C-US

CSA-approved: Certification for use in Canada and USA

Class I, Division 1 Groups C & D, T4

Marine approval classifications

Marine Approval

Country

Lloyds London	United Kingdom
Germanische Lloyd	Germany
Det Norske Veritas	Norway
Bureau Veritas	France
RINA	Italy
American Bureau of Shipping	USA
Nippo Kaiji Kyokai	Japan
Russian Maritime Register of Shipping	Russia
Korean Register of Shipping	Korea

General classifications

Electromagnetic compatibility

All versions conform to the latest international standards for EMC, and are compliant with EN 61326/IEC 61326.

Environment

- Weather rating: IP66

Materials of construction

Wetted parts	316L Stainless steel
Tine finish	PFA laminated ⁽¹⁾
Electronics enclosure	Sand cast low copper alloy Polyurethane paint finish

(1) PFA is applied only to the tines for its anti-stick properties not for corrosion protection.

Weight

Weight	3,4 kg typical
---------------	----------------

Electrical

Power supply requirement	For transmitter For mA outputs	20 to 28 VDC, 50 mA 22 mA per output
Outputs	mA Accuracy Repeatability Out-of-range System alarm	Two passive 4–20 mA ±0,1% of reading, ±0,05% of full scale at 20 °C ±0,05% of full scale, over range –40 °C to +85 °C 3,9 or 20,8 mA on 4–20 mA 2 or 22 mA on 4–20 mA (Programmable alarm state)
	Communications	RS-485 (Modbus)
Electrical connection	Screw terminal, cable entry to suit ½" NPT gland (20 mm adaptor available)	

Dimensions

Dimensions in mm

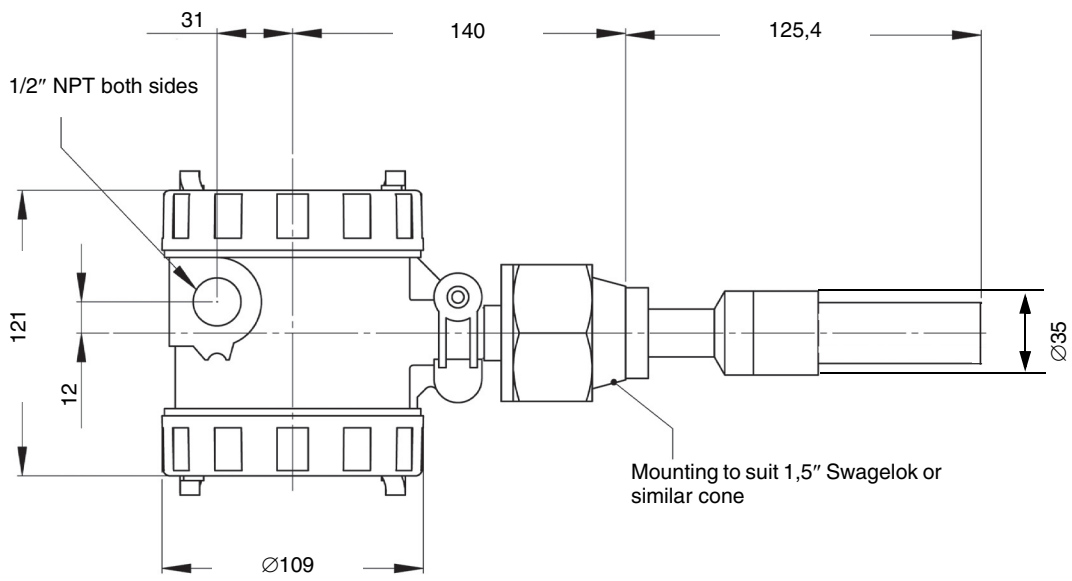

Installation

A variety of installation accessories are available for both inline and slipstream/bypass installations. Additionally, retrofit adapter kits are available for easy replacement of other viscosity measurement technologies. For more information on these installation accessories, see the Micro Motion® 7829 Viscomaster® Series Accessories product data sheet available at www.micromotion.com.

Fuel heater control example

Most marine and land-based engine/burner applications use a fuel booster module to precondition the heavy fuel oil (HFO) prior to injection. These modules usually consist of a number of supply pumps fed by either HFO or MDO, a flow meter, in-line filters to remove the impurities, and a holding/mixing tank. Following the supply section, the fuel is usually sent to booster pumps that increase the flow rate up to a maximum of 20 m³/hr and then through a series of heat exchangers (liquid or electric) to change the product viscosity for efficient combustion.

Following is a graphic that shows the different installation options for the 7829 Viscomaster in a fuel booster module.

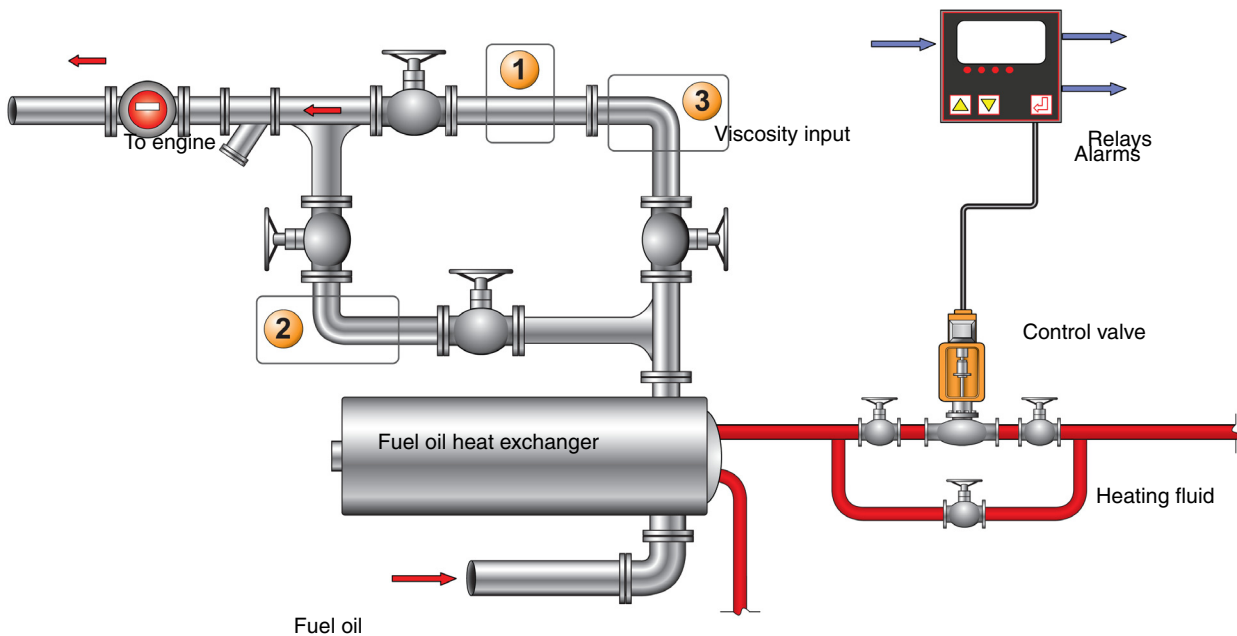

- 1** Inline viscosity meter replacement (VAF Viscosense retrofit)

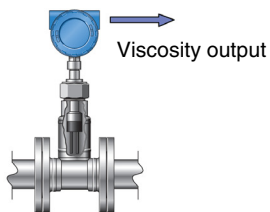

- 2** Micro Motion flow-through-chamber installation

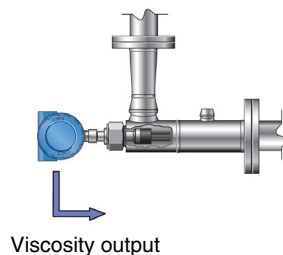

- 3** Capillary viscosity meter replacement (VAF Viscotherm or Nakakita retrofit)

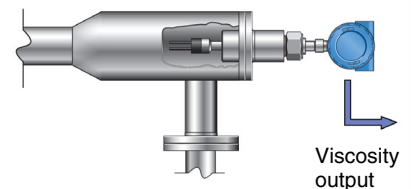

Ordering Information

Model	Product description
7829	Viscosity meter
Code	Material of wetted parts
F	316L Stainless steel, PFA laminated tines
Code	Amplifier system
E	Advanced: 4–20 mA output, ATEX Ex d IIC T4, < 200 °C
F	Advanced: 4–20 mA output, CSA Class 1 Division 1, Groups C & D, < 200 °C
Code	Amplifier enclosure
A	Aluminium alloy [T4 (< 40 °C < Ta < +110 °C)]
Code	Process connections
N	1,5" Cone seat compression fitting
Code	Stem length
A	0 mm: no stem extension and with standard spigot
Code	Default software configuration of 4–20 mA output 1 ⁽¹⁾
H	0 to 25 cSt
J	0 to 50 cSt
E	0 to 100 cSt
Z	ETO custom configuration
Code	Calibration range
B	0,5 to 100 cP
Code	Calibration type
A	Free stream
B	2" schedule 40 boundary (200 cP limit)
E	3" schedule 80 boundary ⁽²⁾
H	2-1/2" schedule 40 boundary
J	80 mm boundary ⁽³⁾
Z	ETO calibration type
Code	Factory Set
B	Reserved for future use
Code	Traceability
A	None
X	Certificates of material traceability (per single order)

Typical model number: 7829FEANAHRABA

(1) 4–20 mA output 2 default setting is temperature.

(2) Compatible with DN80 XS pipework.

(3) With a minimum wall thickness of 6 mm.

Micro Motion—The undisputed leader in flow and density measurement



World-leading Micro Motion measurement solutions from Emerson Process Management deliver what you need most:

Technology leadership

Micro Motion introduced the first reliable Coriolis meter in 1977. Since that time, our ongoing product development has enabled us to provide the highest performing measurement devices available.

Product breadth

From compact, drainable process control to high flow rate fiscal transfer—look no further than Micro Motion for the widest range of measurement solutions.

Unparalleled value

Benefit from expert phone, field, and application service and support made possible by more than 600000 meters installed worldwide and over 30 years of flow and density measurement experience.

 www.micromotion.com

© 2011 Micro Motion, Inc. All rights reserved.

The Micro Motion and Emerson logos are trademarks and service marks of Emerson Electric Co. Micro Motion, ELITE, MVD, ProLink, MVD Direct Connect, and PlantWeb are marks of one of the Emerson Process Management family of companies. All other trademarks are property of their respective owners.

Micro Motion supplies this publication for informational purposes only. While every effort has been made to ensure accuracy, this publication is not intended to make performance claims or process recommendations. Micro Motion does not warrant, guarantee, or assume any legal liability for the accuracy, completeness, timeliness, reliability, or usefulness of any information, product, or process described herein. We reserve the right to modify or improve the designs or specifications of our products at any time without notice. For actual product information and recommendations, please contact your local Micro Motion representative.

Emerson Process Management Micro Motion Americas

Worldwide Headquarters
7070 Winchester Circle
Boulder, Colorado USA 80301
T: 800 522 6277
T: +1 (303) 527 5200
F: +1 (303) 530 8459
Mexico T: 52 55 5809 5300
Argentina T: 54 11 4837 7000
Brazil T: 55 15 3238 3527
Venezuela T: 58 26 1792 1858

Emerson Process Management Micro Motion Europe/Middle East

Central & Eastern Europe T: +41 41 7686 111
Dubai T: +971 4 811 8100
France T: 0800 917 901
Germany T: 0800 182 5347
Italy T: 8008 77334
The Netherlands T: (31) 318 495 555
Belgium T: +32 (0) 2 716 77 11
Spain T: +34 913 586 000
U.K. T: 0870 240 1978
Russia/CIS T: +7 495 981 9811

Emerson Process Management Micro Motion Asia Pacific

Australia T: (61) 3 9721 0200
China T: (86) 21 2892 9000
India T: (91) 22 6662 0566
Japan T: (81) 3 5769 6803
Korea T: (82) 2 3438 4600
Singapore T: (65) 6 777 8211

For a complete list of contact information and websites, please visit: www.emersonprocess.com/home/contacts/global.

