

Product Data Sheet

PS-00717, Rev. C

January 2008

Micro Motion® Model 1500 Transmitter with the Filling and Dosing Application

Micro Motion's Model 1500 transmitter with the filling and dosing application offers all the benefits of MVD™ technology, in a package specifically designed for filling, dosing, and bottling processes.

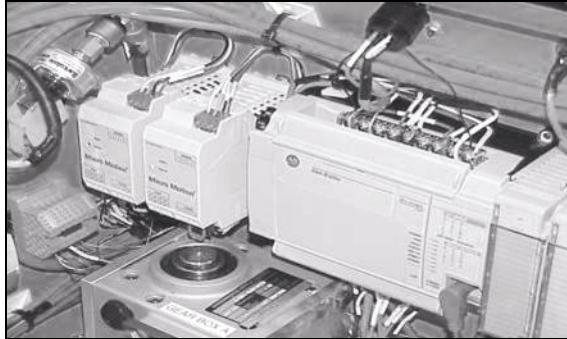

2400S

Compact integral transmitter

1700
2700

Versatile field-mount transmitter

**1500
2500**

Compact control-room transmitter

3300
3350

Frequency-input discrete controller

3500
3700

Integrated control and measurement platform

Integrated architecture optimized for filling performance

- Discrete valve control for best repeatability
- Real-time density and temperature measurement for quality control
- Automatic overshoot compensation for on-set-point fills every time
- Compatible with CIP, SIP, and EHEDG requirements

Flexibility for simplified system design

- Compact size to maximize heads for rotary and linear filling systems
- Integral valve control for easy integration with control system
- Faster product turn-over due to cleanable sensor design
- Scalability to handle a wide range of container sizes and fillers with a single platform



Micro Motion Model 1500 transmitter with the filling and dosing application

Micro Motion's Model 1500 transmitter with the filling and dosing application combines the benefits of Micro Motion MVD™ technology, a software package specially designed for filling, dosing, and bottling processes, and compatibility with a wide range of sensors, including hygienic models for CIP, SIP, and EHEDG certification.

Filling and dosing application. Micro Motion's new patented filling and dosing application is packed with features for precise control and delivery of small quantities of fluids over broad ranges of process conditions.

- Measure by mass or volume, with sensor accuracies up to 0.05%, independent of changes in temperature, density, or viscosity.
- Measure a wide range of both liquids and gases, including liquids with entrained air and suspended solids. We have experience with high-viscosity pastes, creams, emulsions, and slurries.
- Instantly validate product quality using the secondary density or temperature measurement, eliminating the need for expensive lab checks.
- Special update rate between transmitter and sensor enables near-instantaneous response
- Overshoot compensation (OC) automatically adjusts the valve closure signal to accommodate changing process conditions
- User-selectable OC algorithms: never overfill, never underfill, fixed, rolling average
- Select from a variety of standard measurement units, or define your own
- Set up one-stage or two-stage filling, using standard discrete (ON/OFF) valves, or configure the transmitter to control a three-position analog valve
- Automatic or manual purge cycle
- Sensors suitable for both CIP and SIP cleaning, enabling rapid product changeover

Contents

Model 1500 platform	3	Environmental limits	8
Application architecture and process.	4	Environmental effects	8
Accuracy, reliability, and repeatability	5	Hazardous area classifications	9
User interface	6	Physical specifications	9
Electrical connections	7	Transmitter dimensions	10
Input/output signals	7	Remote core processor dimensions	11
Digital communications	8	Ordering information	12
Power supply	8		

Model 1500 platform

Micro Motion's popular Model 1500 transmitter provides the platform for the filling and dosing application.

The Model 1500 delivers a big transmitter in a small package. Designed for DIN rail mounting, it measures a tiny 4" × 4.5" × 1.8" — perfect for carousels or skids.

Embedded MVD technology provides front-end digital processing, for dramatically reduced signal noise, faster response time, and expanded diagnostics.

The Model 1500 connects to a wide range of Micro Motion sensors, using standard 4-wire cable for significantly reduced installation costs. And because the sensor is powered by the transmitter, there's no need to run separate power to the sensor.

Three input/output channels can be configured for mA output, discrete output, discrete input, or three-position analog valve control.

A status LED on the transmitter face indicates transmitter health at a glance.

Meter verification. Meter verification is an application available in conjunction with Micro Motion ELITE® meters utilizing the enhanced core processor. Initiated by a user command, the method measures mechanical characteristics of the meter to a very high accuracy. When a change in the structural stiffness of the sensor tubes is detected, the device indicates the meter may no longer meet factory specifications. The structural integrity test verifies complete meter performance from tube structure to electronics to signal processing for complete performance certainty.

Application architecture and process

Simple one-stage fill process

The host downloads the target to the Model 1500, which opens the controlling valve. When the target is reached, the Model 1500 closes the controlling valve and reports the totals to the host system.

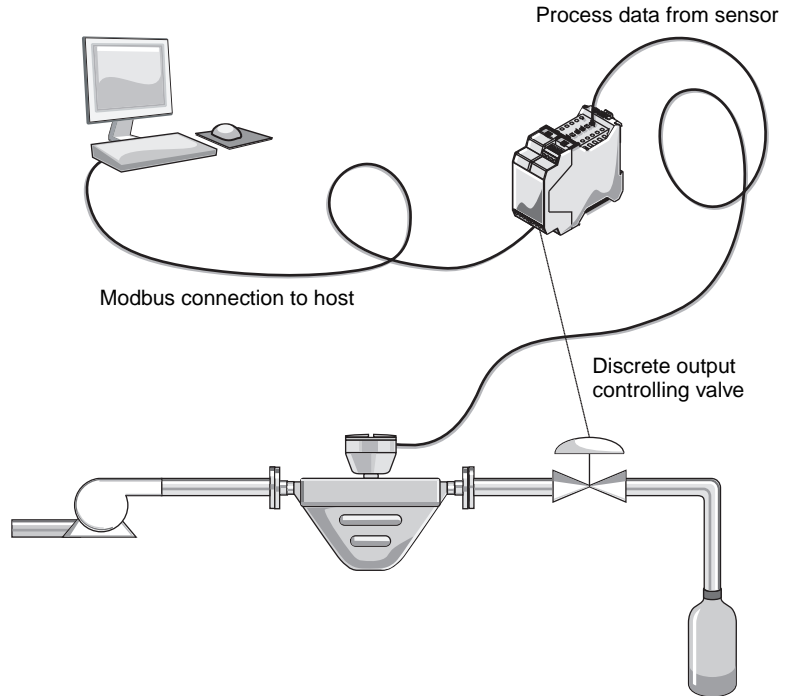

Two-stage control

One of several two-stage control schemes is illustrated here. The secondary valve opens to start the fill. The primary valve opens and closes at user-configured points during the fill. The secondary valve closes slightly before the target is reached, at a point determined by the Overshoot Compensation feature.

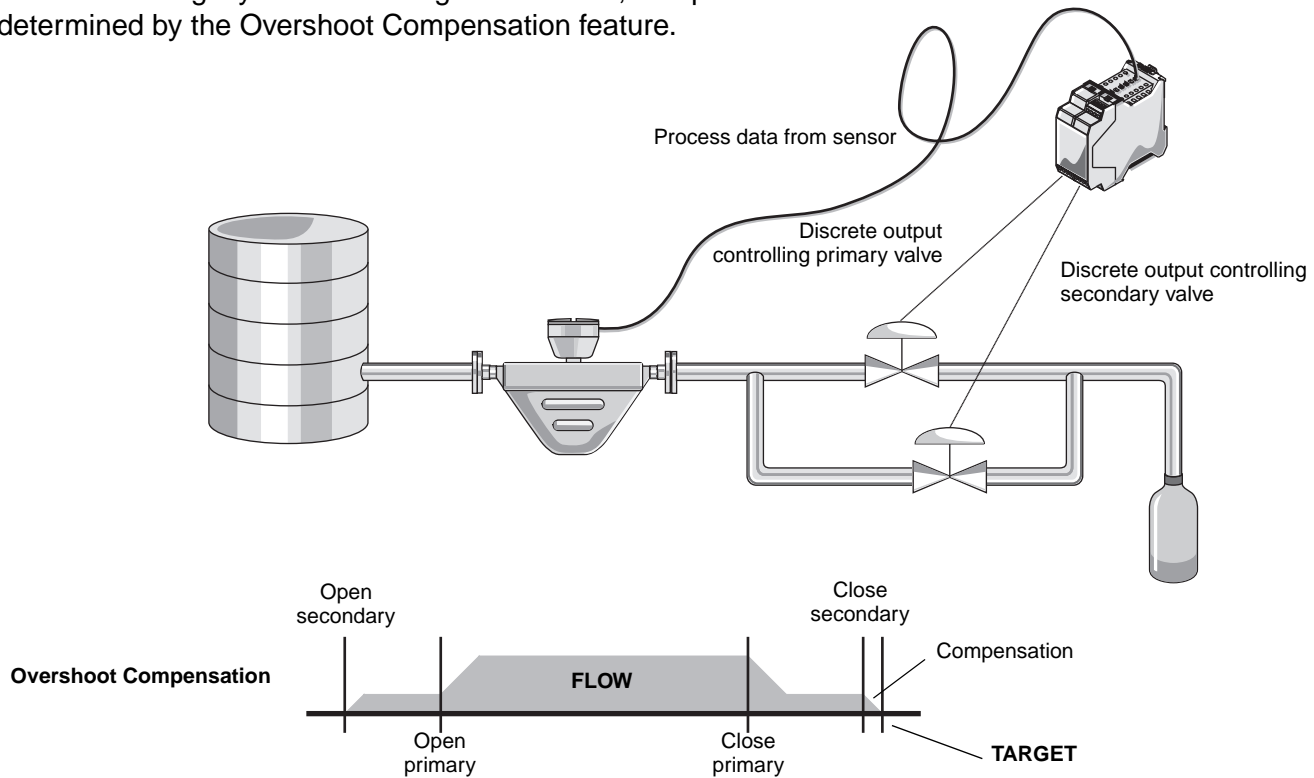

Accuracy, reliability, and repeatability

The Model 1500 transmitter with the filling and dosing application can be paired with any 4-wire or 9-wire Micro Motion sensor to provide highly accurate and repeatable mass flow, volume flow, density, and temperature measurements, all in real time.

Underfilling a container puts the producer at risk with customers and regulatory agencies, yet overfilling can create significant cost issues, as well as possible problems with spills, safety, and cleanup. Reducing the variation in product fills can have a significant impact on a manufacturer's bottom line. Typical system accuracies provide standard deviation of fills below 0.2.

A program that combines a Micro Motion measurement system with statistical quality control (SQC) analysis can allow you to lower the fill target—"squeeze and shift"—and reduce overfill while still meeting regulatory requirements.

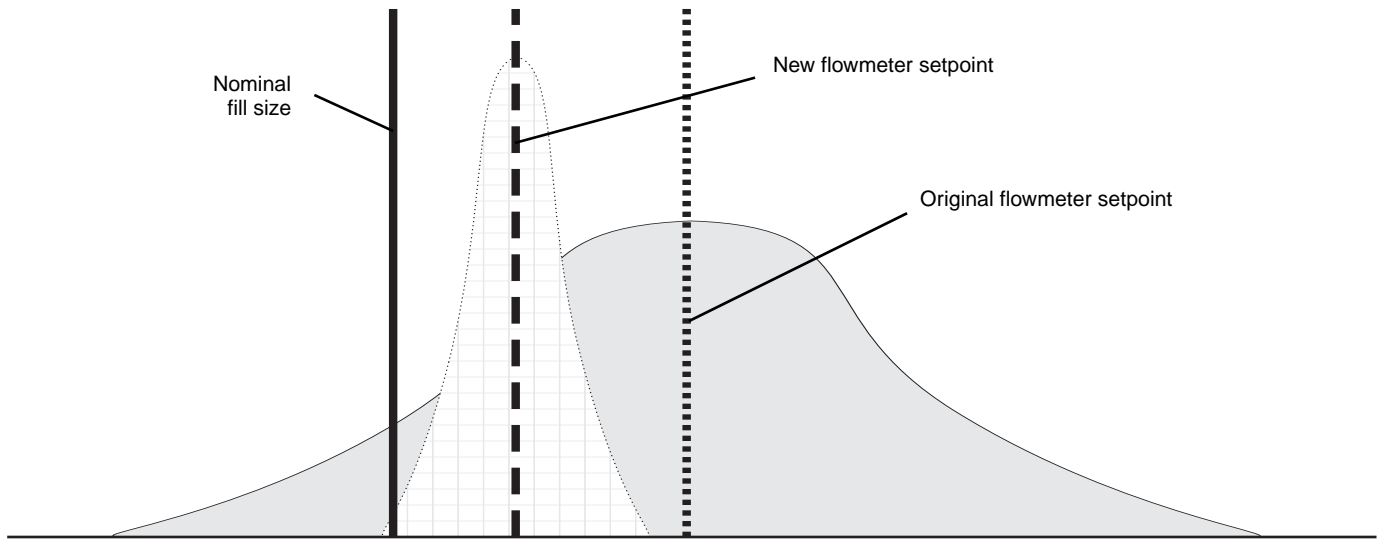

User interface

ProLink® II

Micro Motion's ProLink® II software provides a simple, powerful interface to the Model 1500 transmitter and the filling and dosing application. Designed for both configuration and operation, it runs on almost any Microsoft Windows platform, and can be connected to the transmitter on a temporary or permanent basis.

User-written programs

For users who want to integrate control and measurement into their own programs, complete documentation of the Modbus interface to the transmitter and the application is available from Micro Motion.

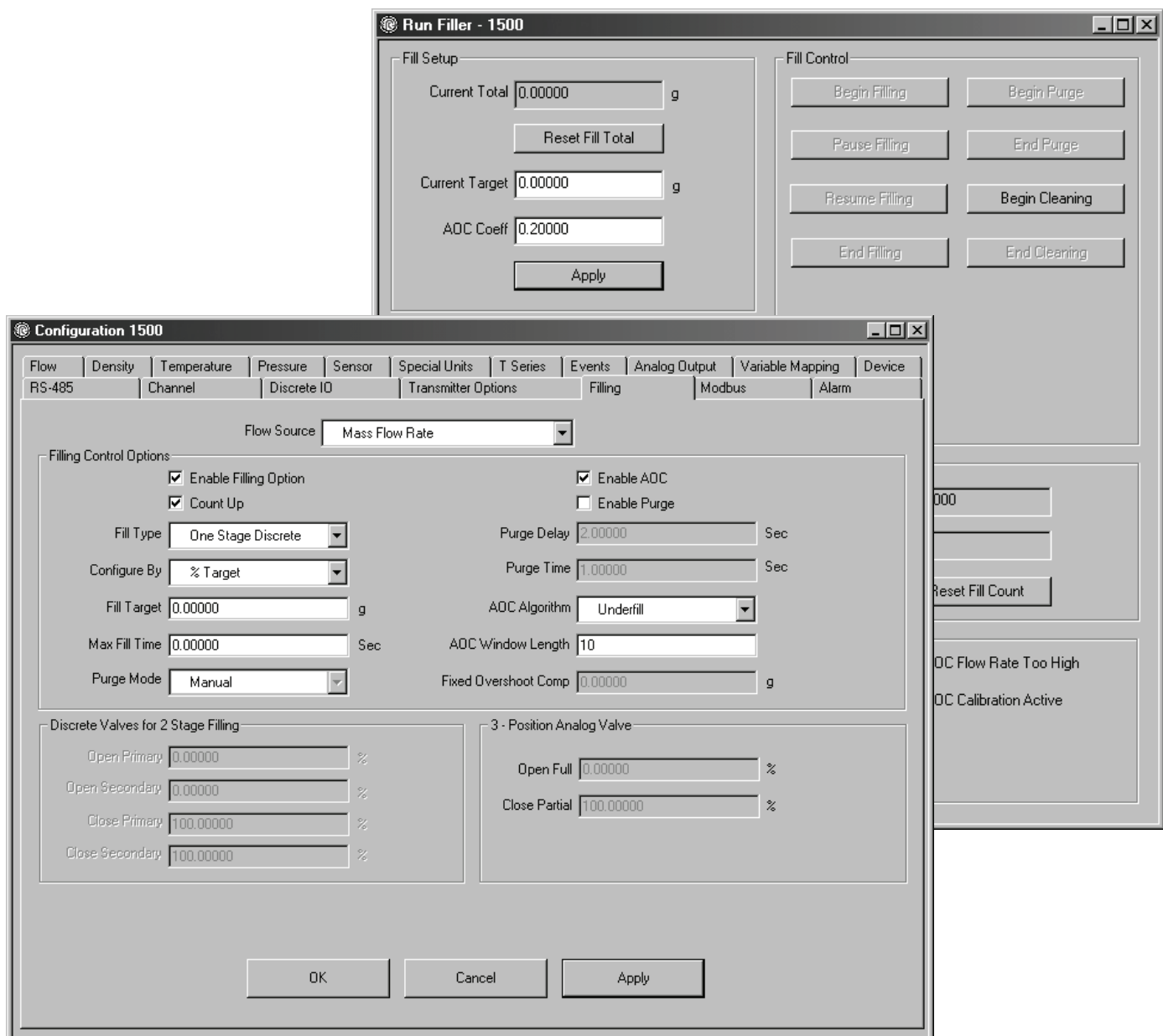

Specifications

Electrical connections

Input/output connections	Three pairs of wiring terminals for transmitter outputs One pair of terminals for digital communications (Modbus/RS-485) Screw terminals accept stranded or solid conductors, 24 to 12 AWG (0.20 to 3.5 mm ²)
Power connection	Two pairs of terminals for the power connection: <ul style="list-style-type: none">• Either pair accepts DC power• The remaining pair is used for making a jumper connection to another transmitter Screw terminals accept stranded or solid conductors, 24 to 12 AWG (0.20 to 3.5 mm ²)
Service port connection	One pair of terminals supports Modbus/RS-485 signal or service port mode. On device power-up, user has 10 seconds to connect in service port mode. After 10 seconds, the terminals default to Modbus/RS-485 mode.
Core processor connection	Two pairs of terminals for the 4-wire connection to the core processor: <ul style="list-style-type: none">• One pair is used for the RS-485 connection to the core processor• One pair is used to supply power to the core processor Screw terminals accept stranded or solid conductors, 24 to 12 AWG (0.20 to 3.5 mm ²)

Input/output signals

One active 4–20 mA output	Not intrinsically safe Isolated to ± 50 VDC from all other outputs and earth ground Maximum load limit: 600 Ω Can report mass flow or volume flow, or can control a two-position discrete valve or three-position analog valve Output is linear with process from 3.8 to 20.5 mA, per NAMUR NE43 (June 1994)
One or two discrete outputs	Channels B and C can be configured as discrete outputs Can report fill in progress or fault, or can control discrete valve Maximum sink capability is 500 mA Configurable for internal or external power: <ul style="list-style-type: none">• Internally powered to 15 VDC $\pm 3\%$, internal 2.2 kΩ pull-up, or• Externally powered 3–30 VDC max., sinking up to 500 mA at 30 VDC maximum
One discrete input	Channel C can be configured as a discrete input Configurable for internal or external power Can be used to begin fill, end fill, pause fill, resume fill, reset fill total, reset mass total, reset volume total, or reset all totals (includes fill total)
One zero button	Used to start the flowmeter zeroing procedure

Specifications *continued*

Digital communications

Service port	After device power up, terminals 33 and 34 are available in service port mode for 10 seconds: <ul style="list-style-type: none">• Modbus RTU protocol• 38,400 baud• No parity• One stop bit• Address = 111
Modbus/RS-485	After 10 seconds, terminals 33 and 34 default to Modbus/RS-485: <ul style="list-style-type: none">• Modbus RTU or Modbus ASCII protocol (default: Modbus RTU)• 1200 to 38,400 baud rate (default: 9600)• Stop bit configurable (default: one stop bit)• Parity configurable (default: odd parity)

Power supply

Requires DC power	Meets Installation (Overvoltage) Category II, Pollution Degree 2 requirements
Power requirements	19.2 to 28.8 VDC, 6.3 watts maximum At startup, transmitter power source must provide a minimum of 1.0 amperes of short-term current per transmitter Length and conductor diameter of the power cable must be sized to provide 19.2 VDC minimum at the power terminals, at a load current of 330 mA
Fuse	IEC 1.6A slowblow fuse

Environmental limits



Ambient temperature limits	<ul style="list-style-type: none">• Operating: -40 to +131 °F (-40 to +55 °C)• Storage: -40 to +185 °F (-40 to +85 °C) If temperature is above 113 °F (45 °C) and you are mounting multiple transmitters, they must be mounted at least 8.5 mm apart.
Humidity limits	5 to 95% relative humidity, non-condensing at 140 °F (60 °C)
Vibration limits	Meets IEC68.2.6, endurance sweep, 5 to 2000 Hz, 50 sweep cycles at 1.0 g

Environmental effects

EMI effects	Meets EMC directive 89/336/EEC per EN 61326 Industrial Complies with NAMUR NE21 (May 1999)
Ambient temperature effect	On analog output $\pm 0.005\%$ of span per °C

Specifications *continued*

Hazardous area classifications

CSA ⁽¹⁾ C-US		Transmitter	Class I, Div. 2, Groups A, B, C, and D
		Sensor and sensor wiring to transmitter	Class I, Div. 1, Groups C and D or Class II, Div. 1, Groups E, F, and G
ATEX ⁽²⁾		CE 0575 ATEX II(2) G [EEx ib] IIB/IIC For ATEX compliance, ambient temperature is limited to –40 to +131 °F (–40 to +55 °C)	

(1) CSA is a Canadian approvals agency that provides approvals accepted both in Canada and in the U.S.A. (C-US).

(2) ATEX is a European directive.

Physical specifications

Housing	Polyamide PA 6.6		
Weight	0.52 lbs (0.24 kg)		
Dimensions	See following figures for dimensions of the Model 1500 transmitter and the remote core processor. For sensor dimensions, refer to sensor specifications.		
Status LED	Three-color LED status light on face of transmitter indicates flowmeter condition at a glance, using a solid green, yellow or red light. Zero in progress is indicated by a flashing yellow light.		
Zero button	A zero button on the face of the transmitter can be used to start the transmitter zero process.		
Mounting and cabling	DIN rail transmitters are mounted on a 35 mm rail which requires an independent ground. They may be used with any Micro Motion 4-wire or 9-wire sensor. For a 4-wire connection, use standard 4-wire twisted-pair shielded signal cable, up to 1000 feet (300 meters) in length, between the sensor and the transmitter. For 9-wire sensors, the remote core processor must be mounted within 60 feet (20 meters) of the sensor, using 9-wire Micro Motion signal cable. The transmitter can then be mounted up to 1000 feet (300 meters) from the remote core processor.		
Maximum cable lengths between sensor and transmitter	Cable type	Wire gauge	Maximum length
	Micro Motion 9-wire	Not applicable	60 feet (20 meters) ⁽¹⁾
	Micro Motion 4-wire	Not applicable	1000 feet (300 meters)
	User-supplied 4-wire ⁽²⁾		
	• Power wires (VDC)	22 AWG (0.35 mm ²) 20 AWG (0.5 mm ²) 18 AWG (0.8 mm ²)	300 feet (90 meters) 500 feet (150 meters) 1000 feet (300 meters)
	• Signal wires (RS-485)	22 AWG (0.35 mm ²) or larger	1000 feet (300 meters)

(1) This is the maximum distance between a remote core processor and the sensor. An additional run of 4-wire cable is needed between the remote core processor and the transmitter.

(2) Micro Motion recommends using Micro Motion cable.

Specifications *continued*

Transmitter dimensions

Dimensions in *inches*
(*mm*)

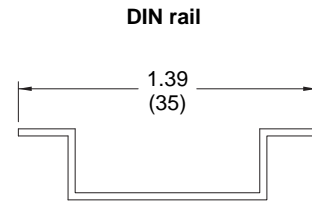
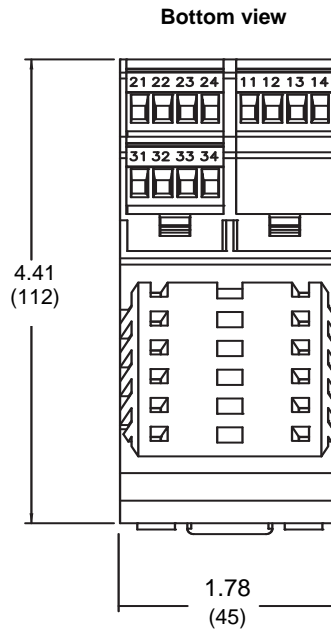
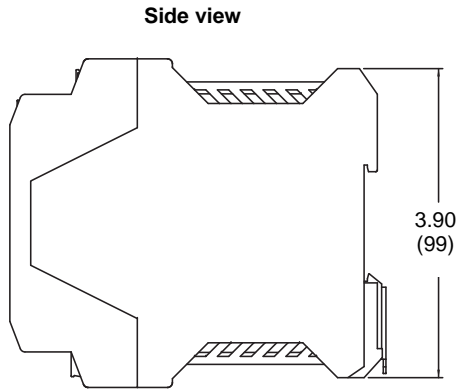

Mounting multiple transmitters
with temperatures above
113 °F (45 °C)

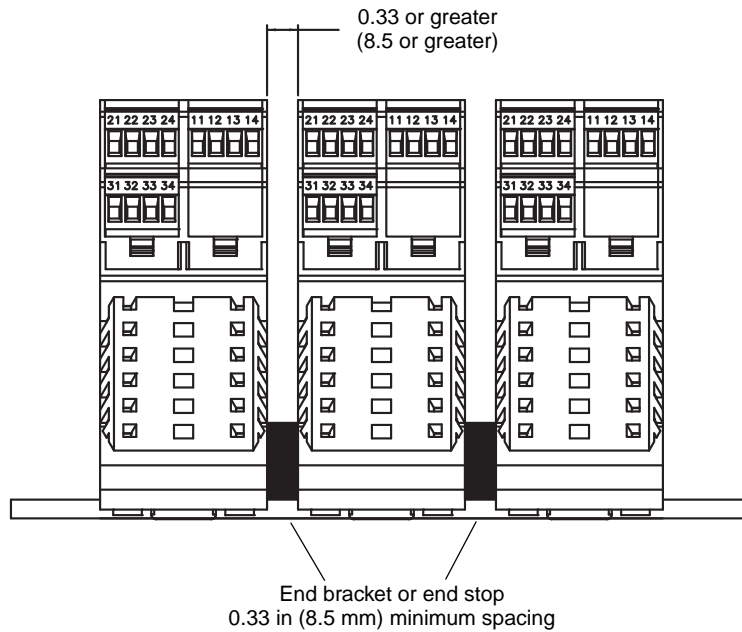

Specifications *continued*

Remote core processor dimensions

Dimensions in inches (mm)

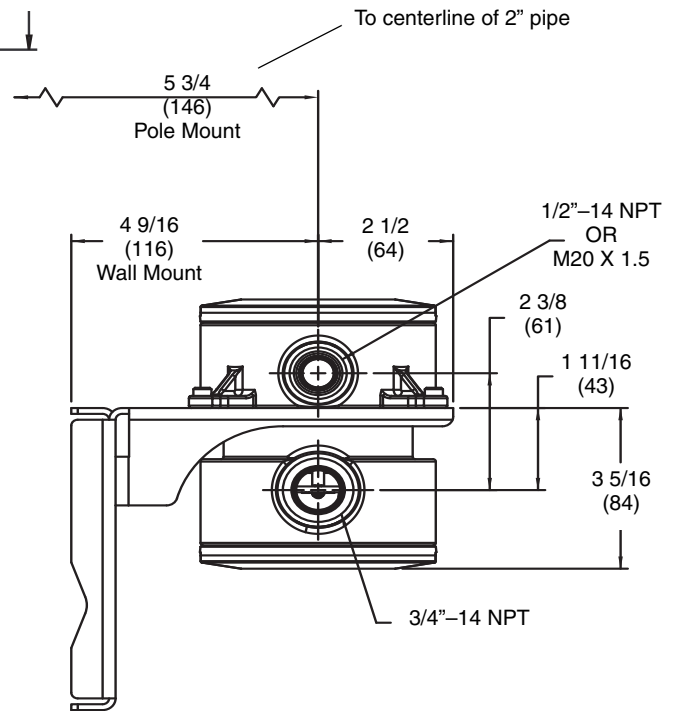
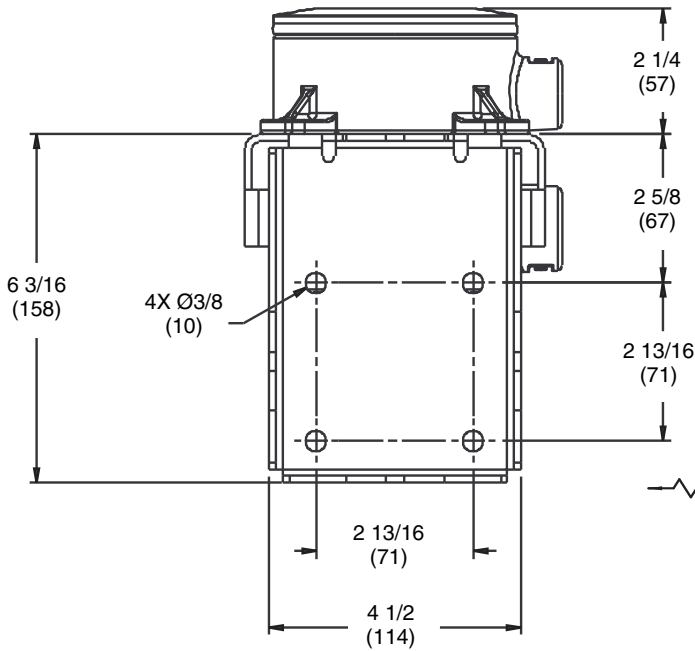
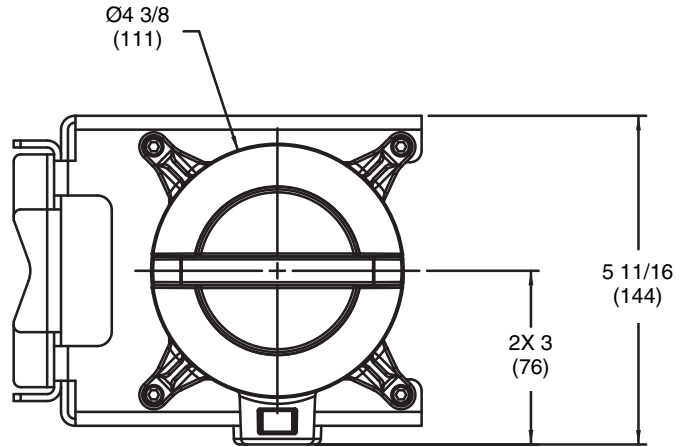
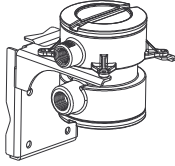

These dimensions apply only to the core processor component when mounted remotely from the sensor. For dimensions of the core processor when mounted integrally with the sensor, see the sensor specifications.

Ordering information

Model	Product description
1500	Micro Motion Coriolis MVD 1500 single variable flow transmitter
Code	Mounting
D	4-wire remote 35 mm DIN rail transmitter
B	4-wire remote 35 mm DIN rail transmitter with 9-wire remote core processor (includes 10 ft [3 m] CFEPS cable)
Code	Power
3	19.2 to 28.8 VDC
Code	Conduit connections
A	None (for use with mounting option code D)
B ⁽¹⁾	1/2-inch NPT remote core processor — no gland
E ⁽¹⁾	M20 remote core processor — no gland
F ⁽¹⁾	Remote core processor — brass/nickel cable gland
G ⁽¹⁾	Remote core processor — stainless steel cable gland
Code	Output options
C	One mA, two DO; RS-485
Code	Terminals
B	Screw terminals
Code	Approvals
M	Micro Motion standard (no approval)
C	CSA (Canada only)
A	CSA C-US (U.S.A. and Canada)
B	ATEX — safe area with intrinsically safe sensor outputs
P ⁽²⁾	NEPSI — safe area
Continued on next page	

(1) Available with mounting code B only.

(2) Available only with language code M (Chinese).

Ordering information *continued*

Code	Language
A	Danish installation manual and English configuration manual
D	Dutch installation manual and English configuration manual
E	English installation manual and English configuration manual
F	French installation manual and French configuration manual
G	German installation manual and German configuration manual
H	Finnish installation manual and English configuration manual
I	Italian installation manual and English configuration manual
J	Japanese installation manual and English configuration manual
M	Chinese installation manual and English configuration manual
N	Norwegian installation manual and English configuration manual
O	Polish installation manual and English configuration manual
P	Portuguese installation manual and English configuration manual
S	Spanish installation manual and Spanish configuration manual
W	Swedish installation manual and English configuration manual
C	Czech CE requirements, English installation manual, and English configuration manual
B	Hungarian CE requirements, English installation manual, and English configuration manual
K	Slovak CE requirements, English installation manual, and English configuration manual
T	Estonian CE requirements, English installation manual, and English configuration manual
U	Greek CE requirements, English installation manual, and English configuration manual
L	Latvian CE requirements, English installation manual, and English configuration manual
V	Lithuanian CE requirements, English installation manual, and English configuration manual
Y	Slovenian CE requirements, English installation manual, and English configuration manual
Code	Software options 1
B	Filling and dosing application
Code	Software options 2
Z	No software options 2
C ⁽¹⁾	Meter verification, structural integrity method
Code	Factory options
Z	Standard product
Typical model number: 1500 D 3 A C B M E B C Z	

(1) Available only with Micro Motion ELITE[®] sensor with enhanced core processor (electronic interface codes 2 and 4).

Micro Motion—The undisputed leader in flow and density measurement



World-leading Micro Motion measurement solutions from Emerson Process Management deliver what you need most:

Technology leadership

Micro Motion introduced the first reliable Coriolis meter in 1977. Since that time, our ongoing product development has enabled us to provide the highest performing measurement devices available.

Product breadth

From compact, drainable process control to high flow rate fiscal transfer—look no further than Micro Motion for the widest range of measurement solutions.

Unparalleled value

Benefit from expert phone, field, and application service and support made possible by more than 500,000 meters installed worldwide and 30 years of flow and density measurement experience.

 WWW.micromotion.com

© 2008 Micro Motion, Inc. All rights reserved. Micro Motion is committed to continuous product improvement. As a result, all specifications are subject to change without notice. ELITE and ProLink are registered trademarks, and MVD and MVD Direct Connect are trademarks of Micro Motion, Inc., Boulder, Colorado. Micro Motion is a registered trade name of Micro Motion, Inc., Boulder, Colorado. The Micro Motion and Emerson logos are trademarks and service marks of Emerson Electric Co. All other trademarks are property of their respective owners.

Emerson Process Management

Micro Motion Americas

Worldwide Headquarters
7070 Winchester Circle
Boulder, Colorado USA 80301
T: 800 522 6277
T: +1 (303) 527 5200
F: +1 (303) 530 8459
Mexico T: 52 55 5366 2622
Argentina T: 54 11 4837 7000
Brazil T: 55 15 3238 3677
Venezuela T: 58 26 1731 3394

Emerson Process Management

Micro Motion Europe/Middle East

Central & Eastern Europe T: +41 41 7686 111
Dubai T: 971-4 8835235
France T: 0800 917 901
Germany T: 0800 182 5347
Italy T: 8008 77334
The Netherlands T: (31) 318 495 555
U.K. T: 0870 240 1978
Russia/CIS T: +7 495 981 9811

Emerson Process Management

Micro Motion Asia Pacific

Australia T: (61) 3 9721 0200
China T: (86) 21 2892 9000
India T: (91) 22 5662 0566
Japan T: (81) 3 5769 6803
Korea T: (82) 2 3438 4600
Singapore T: (65) 6 777 8211

