

Product Data Sheet

PS-001042, Rev. G
March 2011

Micro Motion® ELITE® High Capacity Coriolis Flow and Density Meters

Micro Motion® ELITE® High Capacity Coriolis Meters offer unparalleled flow and density measurement performance in a large size meter.

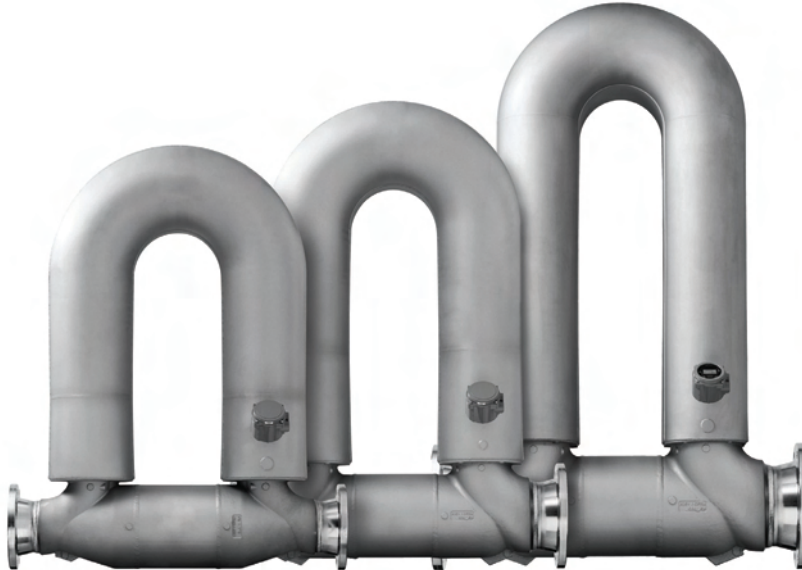

Best precision flow and density measurement in a meter that fits large line sizes

- Unique design delivers unparalleled measurement sensitivity and stability
- Guarantees consistent, reliable performance over the widest flow range
- Smart Meter Verification for quick, complete meter diagnosis without process interruption

Superior performance in the most challenging applications

- Available in Super Duplex for corrosive or high-pressure applications, ideal for oil production sites with sweet crude and brine
- Industry standard for custody transfer and critical process control
- Best two-phase flow capability for batching, loading, and entrained air applications
- Immune to fluid, process, or environmental effects for superb measurement confidence

ELITE® Peak performance Coriolis meter

ELITE HC Peak performance high capacity meter

F-Series High performance compact drainable Coriolis meter

H-Series Hygienic compact drainable Coriolis meter

T-Series Straight tube full-bore Coriolis meter

R-Series General purpose flow-only Coriolis meter

LF-Series Extreme low-flow Coriolis meter



Micro Motion ELITE High Capacity flow and density meters

Micro Motion Coriolis meters from Emerson Process Management meet a vast range of application needs, ranging from extreme low-flow up to high-flow, high-capacity lines. Cryogenic, hygienic, high-temperature, and high-pressure—Micro Motion meters can handle them all. Micro Motion meters are available with a variety of wetted parts to ensure the best material compatibility.

Coriolis meters. Coriolis meters offer dramatic benefits over traditional volumetric measurement technologies. Coriolis meters:

- Deliver accurate and repeatable process data over a wide range of flow rates and process conditions.
- Provide direct inline measurement of mass flow and density, and also measure volume flow and temperature—all from a single device.
- Have no moving parts, so maintenance costs are minimal.
- Have no requirements for flow conditioning or straight pipe runs, so installation is simplified and less expensive.
- Provide advanced diagnostic tools for both the meter and the process.

ELITE High Capacity Coriolis Meters. Micro Motion® ELITE® High Capacity Meters are the leading meters for precision flow and density measurement. ELITE meters offer the most accurate measurement available for virtually any process fluid, while exhibiting exceptionally low pressure drop.

ELITE High Capacity meters are available for:

- Standard applications (316L)
- High temperature applications (316L)
- High chloride applications (Super Duplex)
- High pressure applications (Super Duplex)

Now with Smart Meter Verification, Micro Motion ELITE meters deliver industry-best performance:

- Best measurement and ease of use for critical applications
- Best measurement performance for mass, density, and volume, regardless of process or environmental conditions
- Measurement capability for two-phase flow, liquid, and gas custody transfer

Contents

Liquid flow performance	3	Hazardous area classifications	7
Gas flow performance	3	Materials of construction	9
Density performance (liquid only)	3	Weight and center of gravity	9
Environmental effects	4	Dimensions	10
Temperature specifications	5	Fitting options	13
Power consumption	6	Ordering information	16
Pressure ratings	6		

Liquid flow performance

		Mass		Volume ⁽¹⁾	
		kg/h	metric tons/h	l/h	m ³ /h
Maximum flow rate	CMFHC2	1306000	1306	1306000	1306
	CMFHC3	2550000	2550	2550000	2550
	CMFHC4	3265870	3266	3265870	3266
Mass flow accuracy ⁽²⁾		±0,10% of rate ⁽³⁾			
Volume flow accuracy ⁽²⁾		±0,10% of rate ⁽³⁾			
Repeatability		±0,05% of rate ⁽³⁾			
		kg/h			
Zero stability	CMFHC2	68			
	CMFHC3	136			
	CMFHC4	204			

- (1) Specifications for volumetric flow rate are based on a process-fluid density of 998,2 kg/m³. For fluids with density other than 1000 kg/m³, the volumetric flow rate equals the mass flow rate divided by the fluid's density.
- (2) Stated flow accuracy includes the combined effects of repeatability, linearity, and hysteresis. All specifications for liquids are based on reference conditions of water at 20 to 25 °C and 1 to 2 bar, unless otherwise noted.
- (3) When flow rate is less than zero stability / 0,001, accuracy = ±[(zero stability / flow rate) × 100]% of rate, and repeatability = ±½(zero stability / flow rate) × 100%.

Gas flow performance

When selecting sensors for gas applications, measurement accuracy is a function of fluid mass flow rate independent of operating temperature, pressure, or composition. However, pressure drop through the sensor is dependent upon operating temperature, pressure, and fluid composition. Therefore, when selecting a sensor for any particular gas application, it is highly recommended that each sensor be sized using Micro Motion's product selector, available at www.micromotion.com.

Density performance (liquid only)

Accuracy ⁽¹⁾	±0,5 kg/m ³
Repeatability	±0,2 kg/m ³
Range	up to 5000 kg/m ³

- (1) Accuracy includes the combined effects of repeatability, linearity, and hysteresis. Specifications are based on reference conditions of water at 20 to 25 °C and 1 to 2 bar, unless otherwise noted.

Environmental effects

Process temperature effect

Process temperature effect is defined as:

- For mass flow measurement, the worst-case zero offset due to process fluid temperature change away from the zeroing temperature.
- For density measurement, the maximum measurement offset due to process fluid temperature change away from the density calibration temperature.

Process temperature effect

	% of maximum flow rate per °C	density accuracy per °C ⁽¹⁾ (kg/m ³)
CMFHC2	±0,00025	±0,015
CMFHC3	±0,00025	±0,015
CMFHC4	±0,00025	±0,015

Pressure effect

Pressure effect is defined as the change in sensor flow and density sensitivity due to process pressure change away from the calibration pressure. Pressure effect can be corrected.

Pressure effect on mass flow accuracy

	% of rate per psi	% of rate per bar
CMFHC2	-0,0016	-0,023
CMFHC3	-0,0020	-0,029
CMFHC4	-0,0014	-0,020

Pressure effect on density accuracy

	g/cm ³ per psi	kg/m ³ per bar
CMFHC2	-0,0000028	-0,041
CMFHC3	-0,0000025	-0,037
CMFHC4	-0,0000014	-0,021

(1) For -100 °C and above.

Temperature specifications

Accuracy $\pm 1\text{ }^{\circ}\text{C} \pm 0,5\%$ of reading in $^{\circ}\text{C}$

Repeatability $\pm 0,2\text{ }^{\circ}\text{C}$

Temperature limits⁽¹⁾⁽²⁾⁽³⁾ Standard temperature (316L and Super Duplex) models

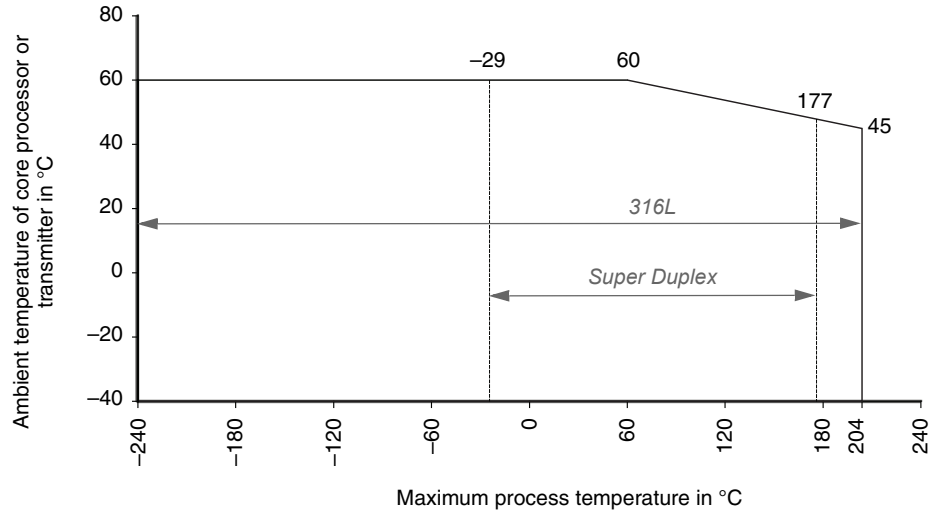

High-temperature (316L) models

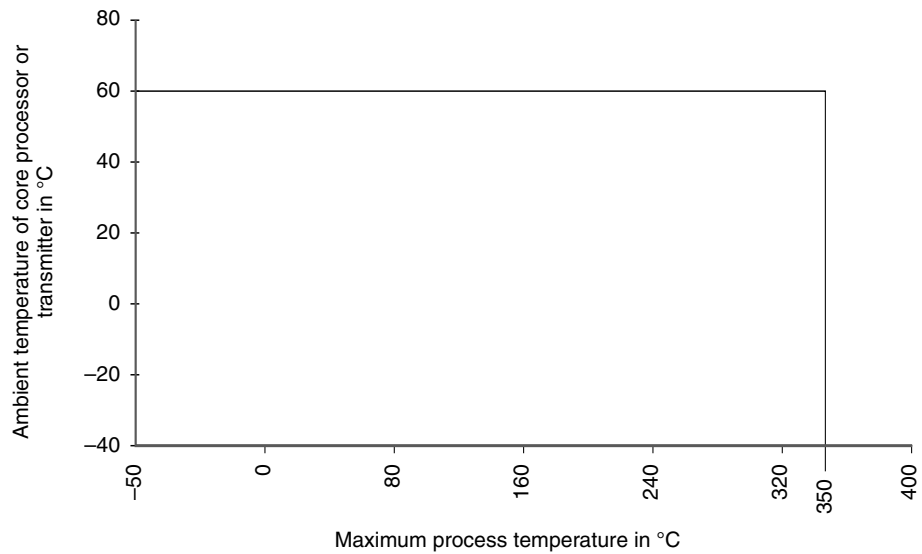

- (1) When ambient temperature is below $-40\text{ }^{\circ}\text{C}$, a core processor or Model 2400S transmitter must be heated to bring its local ambient temperature to between $-40\text{ }^{\circ}\text{C}$ and $+60\text{ }^{\circ}\text{C}$. Long-term storage of electronics at ambient temperatures below $-40\text{ }^{\circ}\text{C}$ is not recommended.
- (2) Temperature limits may be further restricted by hazardous area approvals. See page 7.
- (3) The extended mount option allows the sensor case to be insulated without covering the transmitter, core processor, or junction box, but does not affect temperature ratings.

Pressure ratings

		Design pressure (bar)	Pressure derating (bar)	
			<i>Tmin: -240 °C</i>	<i>Tmax: +204 °C</i>
Sensor rating⁽¹⁾	CMFHC2M	102	102	102
	CMFHC3M	102	102	102
	CMFHC4M	102	102	102
			<i>Tmin: -240 °C</i>	<i>Tmax: +350 °C</i>
	CMFHC2A	102	102	90
	CMFHC3A	102	102	90
		<i>Tmin: -29 °C</i>	<i>Tmax: +177 °C</i>	
	CMFHC3Y	160	160	160

PED compliance Sensors comply with council directive 97/23/EC of 29 May 1997 on Pressure Equipment

(1) Process connection rating may differ from sensor rating. The meter will ship from Micro Motion rated to the pressure rating of the sensor or the pressure rating of the process connection, whichever is lower. Please choose process connections accordingly.

Power consumption

Meter with core processor	4 watts maximum
Meter with Model 2400S transmitter	7 watts maximum
Meter with Model 1700/2700 transmitter	11 watts maximum

Hazardous area classifications

CSA and CSA C-US

Sensor with core processor	Ambient temperature: $-40\text{ }^{\circ}\text{C}$ to $+60\text{ }^{\circ}\text{C}$ Class I, Div 1, Groups C and D Class I, Div 2, Groups A, B, C and D Class II, Div. 1, Groups E, F, and G
Sensor with Model 2400S transmitter	Ambient temperature: $-40\text{ }^{\circ}\text{C}$ to $+60\text{ }^{\circ}\text{C}$ Class I, Div. 2, Groups, A, B, C, and D Class II, Div. 2, Groups F and G

ATEX and IECEx

IECEX	Sensor with core processor	Ex ib IIB/IIC T1–T5 Gb
	Sensor with Model 2400S transmitter	Ex nA IIC T1–T5 Gc
ATEX	Sensor with core processor	CE 0575 Ex II 2G Ex ib IIB/IIC T1–T5 ⁽¹⁾ Gb II 2D Ex ib IIIC T ⁽¹⁾ °C Db IP65
	Sensor with Model 2400S transmitter	CE 0575 Ex II 3G Ex nA IIC T1–T5 ⁽¹⁾ Gc II 3D Ex tc IIIC T ⁽¹⁾ °C Dc IP65

Standard models (CMFHC2M, CMFHC3M, and CMFHC4M) with core processor

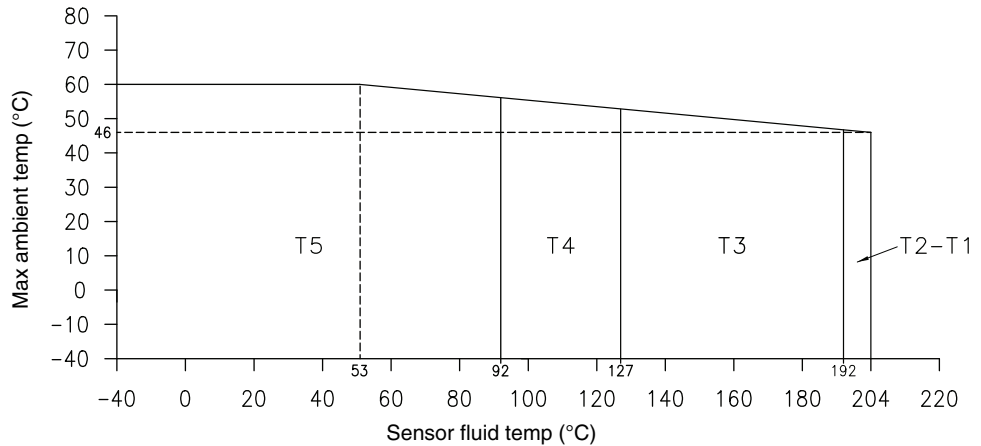

Note 1: Use the temperature graph to determine the temperature class for a given fluid and ambient temperature. The maximum surface temperature T for dust is as follows: T5: $95\text{ }^{\circ}\text{C}$, T4: $130\text{ }^{\circ}\text{C}$, T3: $195\text{ }^{\circ}\text{C}$, T2 to T1: $207\text{ }^{\circ}\text{C}$.

Ambient temperature range T_a $-40\text{ }^{\circ}\text{C}$ to $+60\text{ }^{\circ}\text{C}$

(1) Refer to the temperature graph.

Hazardous area classifications

ATEX and IECEx

High-temperature models (CMFHC2A and CMFHC3A) with core processor

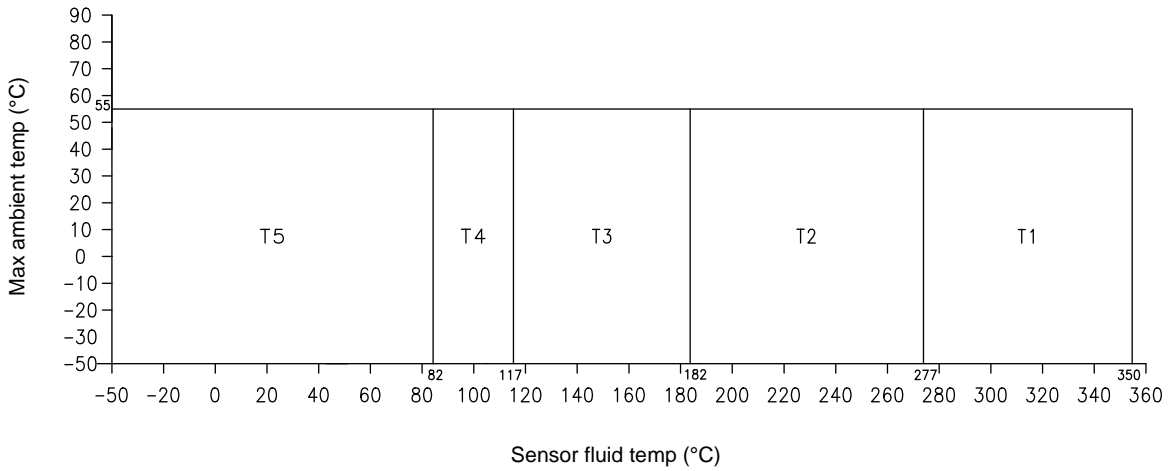

Note 1: Use the temperature graph to determine the temperature class for a given fluid and ambient temperature. The maximum surface temperature T for dust is as follows: T5: 95 °C, T4: 130 °C, T3: 195 °C, T2: 290 °C, T1: 363 °C. The minimum ambient and process fluid temperature allowed for dust is -40 °C.

Ambient temperature range T_a -50 °C to +55 °C

Super Duplex models (CMFHC3Y) with core processor

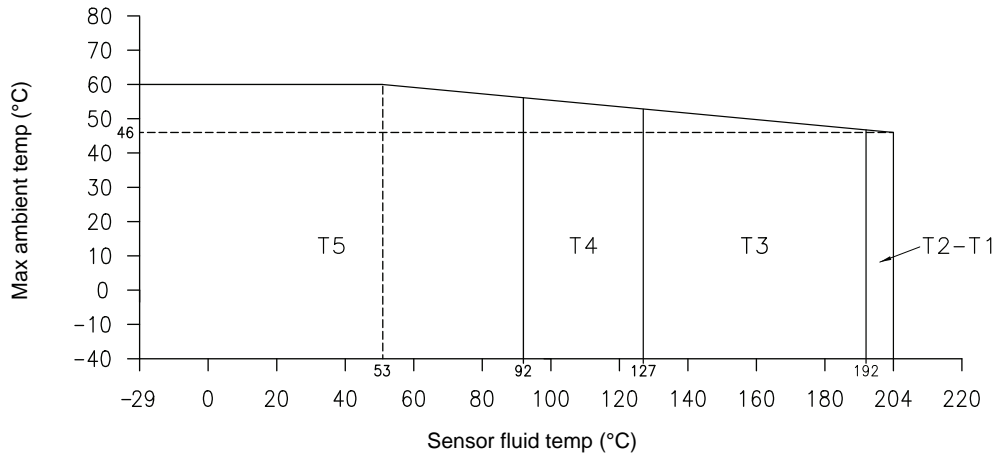

Note 1: Use the temperature graph to determine the temperature class for a given fluid and ambient temperature. The maximum surface temperature T for dust is as follows: T5: 95 °C, T4: 130 °C, T3: 195 °C, T2 to T1: 207 °C. The minimum ambient and process fluid temperature allowed for dust is -40 °C.

Ambient temperature range T_a -40 °C to +60 °C

Materials of construction

Wetted parts⁽¹⁾	316L stainless steel or Super Duplex (UNS S32750)
Housing	304L stainless steel ⁽²⁾
Core processor	Polyurethane-painted aluminum or 300-series stainless steel ⁽²⁾ ; NEMA 4X (IP66)
Model 2400S transmitter	Polyurethane-painted aluminum or 300-series stainless steel ⁽²⁾ ; NEMA 4X (IP66)

(1) General corrosion guides do not account for cyclical stress, and therefore should not be relied upon when choosing a wetted material for your Micro Motion sensor. Please refer to the Micro Motion corrosion guide for proper material compatibility information.

(2) 316L stainless steel is available.

Weight and center of gravity

Weight includes the weight of the sensor with CL150 weld neck raised face flanges, plus the weight of the core processor or Model 2400S transmitter.

		kg
Weight	CMFHC2	248
	CMFHC3	356
	CMFHC4	599

Center of gravity is based on a sensor with integral core processor or Model 2400S transmitter, with meter empty of fluid. Value shown with CL150 flange. Exact center of gravity will vary with the weight of the flange.

		Dim. A (mm)
Center of gravity	CMFHC2	338
	CMFHC3	365
	CMFHC4	465

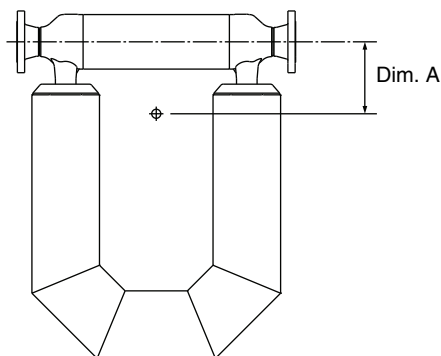

Dimensions

Model CMFHC2M, CMFHC3M, CMFHC3Y, and CMFHC4M

Dimensions in mm

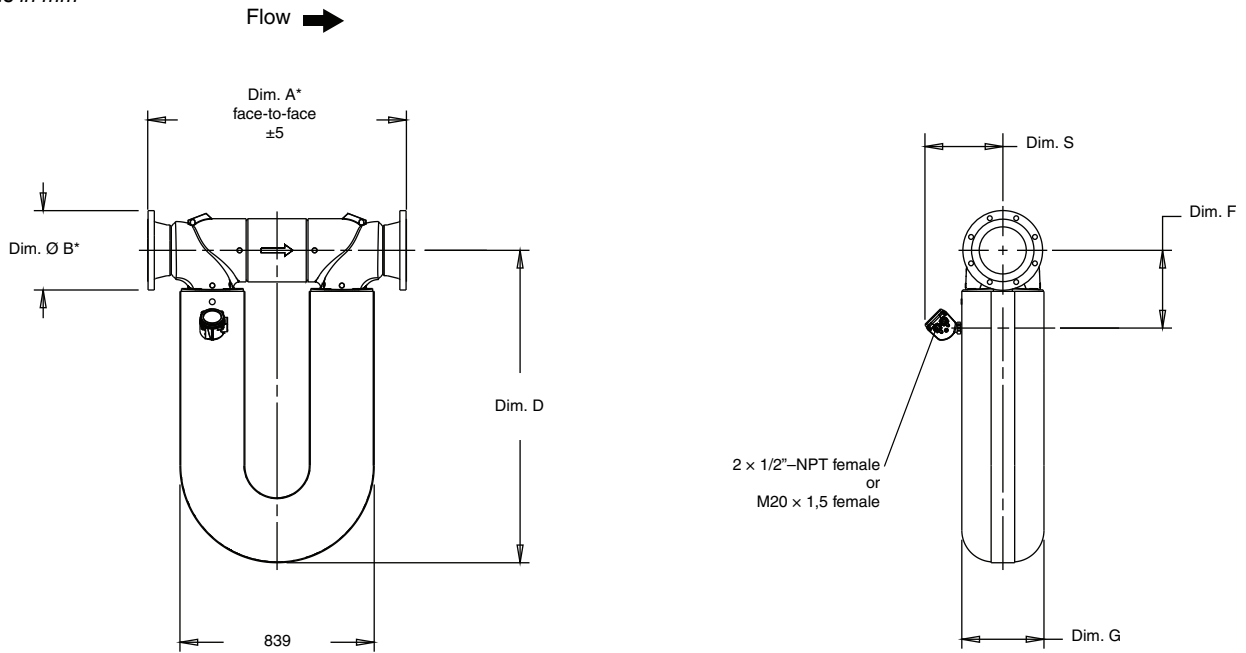

* Note: Dim. A tolerance is ±5 mm for all flanges except fitting codes 451, 452, and 453. For fitting codes 451, 452, and 453 tolerance is ±3 mm.

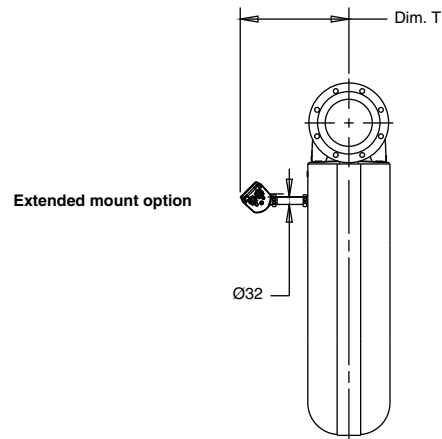

Model	No. of flow tubes	Dimensions (mm) ⁽¹⁾					
		Tube ID	D	F	G	S ⁽²⁾	T ⁽²⁾
CMFHC2	2	89	1234	315	325	323	460
CMFHC3	2	114	1349	335	356	338	470
CMFHC4	2	142	1664	358	451	385	521

(1) For dimensions A and B, see fittings tables on pages 13–15.

(2) Dimensions S and T will vary depending on transmitter/core processor housing material.

Dimensions *continued*

Models CMFHC2A and CMFHC3A

Dimensions in mm

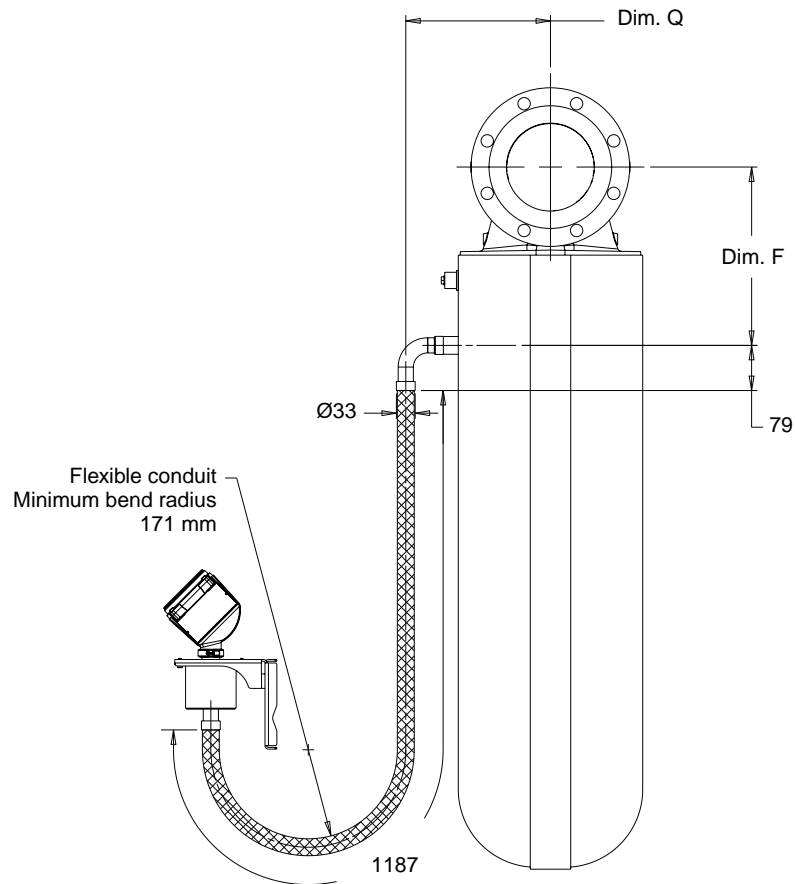

* For additional sensor dimensions, see page 10.

Model	Dimensions (mm)	
	F	Q
CMFHC2A	315	228
CMFHC3A	335	258

Dimensions *continued*

Electronics mounted on high-temperature sensor flexible conduit

Dimensions in mm

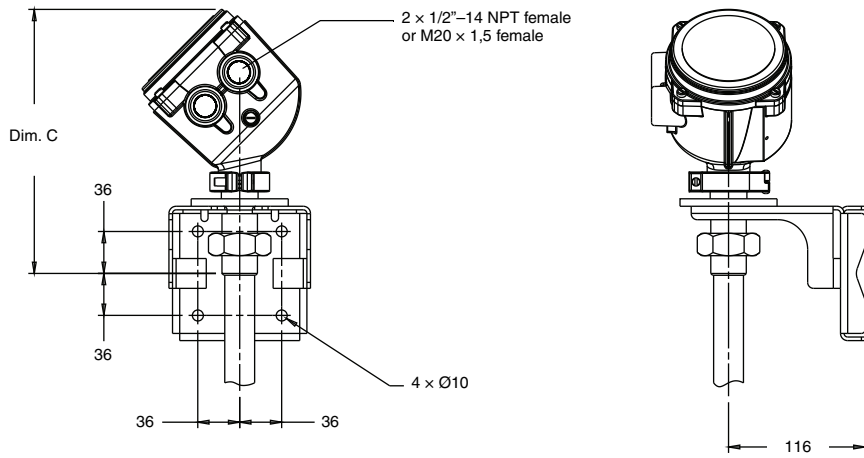

Electronics interface option		Dim. C (mm)
0	Model 2400S transmitter, painted aluminum housing	225
	Model 2400S transmitter, stainless steel housing	235
2	Core processor, painted aluminum housing	225
3	Core processor, stainless steel housing	235

Fitting options

Model CMFHC2

Process fitting	Code ⁽¹⁾	Dim. A ⁽²⁾	Dim. B
	316L	face-to-face (mm)	outside dia. (mm)
6-inch ANSI CL150 weld neck raised face flange	451	1087	279
6-inch ANSI CL300 weld neck raised face flange	452	1107	318
6-inch ANSI CL600 weld neck raised face flange	453	1157	356
6-inch ANSI CL900 weld neck raised face flange	821	1201	381
8-inch ANSI CL150 weld neck raised face flange	810	1111	343
8-inch ANSI CL300 weld neck raised face flange	811	1131	381
8-inch ANSI CL600 weld neck raised face flange	818	1187	419
8-inch ANSI CL900 weld neck raised face flange	819	1245	470
DN150 PN40 weld neck flange; EN 1092-1 Form B1	822	1059	300
DN150 PN100 weld neck flange; EN 1092-1 Form B2	823	1139	355
DN150 PN160 weld neck flange; EN 1092-1 Form B2	824	1165	355
DN200 PN40 weld neck flange; EN 1092-1 Form B1	801	1084	375
DN200 PN100 weld neck flange; EN 1092-1 Form B2	802	1168	430
DN200 PN160 weld neck flange; EN 1092-1 Form B2	803	1188	430

(1) Fittings listed here are standard options. Other types of fittings are available. The face to face dimensions for any custom fittings ordered using a 998 or 999 fitting code are not represented in this table. It is necessary to confirm face to face dimensions of these fittings at time of ordering. Contact your local Micro Motion representative.

(2) Tolerance for Dim. A is ± 5 mm for all fittings except codes 451, 452, and 453. For codes 451, 452, and 453 tolerance is ± 3 mm.

Fitting options *continued*

Model CMFHC3

Process fitting	Code ⁽¹⁾		Dim. A ⁽²⁾ face-to-face (mm)	Dim. B outside dia. (mm)
	316L	Super Duplex		
8-inch ANSI CL150 weld neck raised face flange	810	831	1111	343
8-inch ANSI CL300 weld neck raised face flange	811	832	1131	381
8-inch ANSI CL600 weld neck raised face flange	818	833	1187	419
8-inch ANSI CL600 lap joint flange	812	—	1187	419
8-inch ANSI CL900 weld neck raised face flange	819	834	1245	470
10-inch ANSI CL150 weld neck raised face flange	813	836	1114	406
10-inch ANSI CL300 weld neck raised face flange	814	837	1143	445
10-inch ANSI CL600 weld neck raised face flange	815	838	1203	508
10-inch ANSI CL600 lap joint flange	816	—	1264	508
10-inch ANSI CL600 weld neck raised face PD replacement flange	817	—	1119	508
10-inch ANSI CL900 weld neck raised face flange	820	839	1258	546
DN200 PN40 weld neck flange; EN 1092-1 Form B1	801	825	1084	375
DN200 PN100 weld neck flange; EN 1092-1 Form B2	802	826	1168	430
DN200 PN160 weld neck flange; EN 1092-1 Form B2	803	827	1188	430
DN250 PN40 weld neck flange; EN 1092-1 Form B1	804	828	1118	450
DN250 PN100 weld neck flange; EN 1092-1 Form B2	805	829	1222	505
DN250 PN160 weld neck flange; EN 1092-1 Form B2	806	830	1218	515

(1) Fittings listed here are standard options. Other types of fittings are available. The face to face dimensions for any custom fittings ordered using a 998 or 999 fitting code are not represented in this table. It is necessary to confirm face to face dimensions of these fittings at time of ordering. Contact your local Micro Motion representative.

(2) Tolerance for Dim. A is ± 5 mm.

Fitting options *continued*

Model CMFHC4

Process fitting	Code ⁽¹⁾	Dim. A ⁽²⁾	Dim. B
	316L	face-to-face (mm)	outside dia. (mm)
10-inch ANSI CL150 weld neck raised face flange	841	1213	406
10-inch ANSI CL300 weld neck raised face flange	842	1244	445
10-inch ANSI CL600 weld neck raised face flange	843	1327	508
10-inch ANSI CL900 weld neck raised face flange	844	1391	546
12-inch ANSI CL150 weld neck raised face flange	845	1238	483
12-inch ANSI CL300 weld neck raised face flange	846	1270	521
12-inch ANSI CL600 weld neck raised face flange	847	1333	559
12-inch ANSI CL900 weld neck raised face flange	848	1423	610
DN250 PN40 weld neck flange; EN 1092-1 Form B1	849	1220	450
DN250 PN100 weld neck flange; EN 1092-1 Form B2	850	1324	505
DN250 PN160 weld neck flange; EN 1092-1 Form B2	851	1320	515
DN300 PN40 weld neck flange; EN 1092-1 Form B1	852	1240	515
DN300 PN100 weld neck flange; EN 1092-1 Form B2	853	1350	585
DN300 PN160 weld neck flange; EN 1092-1 Form B2	854	1360	585

(1) *Fittings listed here are standard options. Other types of fittings are available. The face to face dimensions for any custom fittings ordered using a 998 or 999 fitting code are not represented in this table. It is necessary to confirm face to face dimensions of these fittings at time of ordering. Contact your local Micro Motion representative.*

(2) *Tolerance for Dim. A is ± 5 mm.*

Ordering information

Standard models

Model	Product description
CMFHC2M	Micro Motion Coriolis ELITE sensor; 150 to 200 mm; 316L stainless steel
CMFHC3M	Micro Motion Coriolis ELITE sensor; 200 to 250 mm; 316L stainless steel
CMFHC4M	Micro Motion Coriolis ELITE sensor; 250 to 300 mm; 316L stainless steel
Code	Process connections
###	See process fitting options on pages 13–15.
Code	Case options
N	Standard pressure containment
Code	Electronics interface
0	Model 2400S transmitter
1	Extended mount Model 2400S transmitter
2	4-wire polyurethane-painted aluminum integral core processor for remote mount transmitters
3	4-wire stainless steel integral core processor for remote mount transmitters
4	4-wire polyurethane-painted aluminum integral extended mount core processor for remote mount transmitters
5	4-wire stainless steel integral extended mount core processor for remote mount transmitters
Code	Conduit connections
	Electronics interface codes 0 and 1
A	No gland
	Electronics interface codes 2, 3, 4, and 5
B	1/2-inch NPT – no gland
E	M20 – no gland
F	Brass/nickel cable gland (cable diameter 8,5 to 10 mm)
G	Stainless steel cable gland (cable diameter 8,5 to 10 mm)
Code	Approvals
	Electronics interface codes 0 and 1
M	Micro Motion Standard (no approval)
N	Micro Motion Standard / PED compliant
2	CSA Class I, Div. 2
V	ATEX Equipment Category 3 (Zone 2) / PED compliant
3	IECEX Zone 2
	Electronics interface codes 2, 3, 4, and 5
M	Micro Motion Standard (no approval)
N	Micro Motion Standard / PED compliant
A	CSA C-US (U.S.A. and Canada)
Z	ATEX Equipment Category 2 (Zone 1) / PED compliant
I	IECEX Zone 1
6	ATEX Equipment Category 2 (Zone 1 – IIC modified) / PED compliant
7	IECEX Zone 1 – IIC modified
Continued on next page	

Ordering information *continued*

Standard models

Code	Language
A	Danish CE requirements document and English installation manual
D	Dutch CE requirements document and English installation manual
E	English installation manual
F	French installation manual
G	German installation manual
H	Finnish CE requirements document and English installation manual
I	Italian installation manual
J	Japanese installation manual
M	Chinese installation manual
N	Norwegian CE requirements document and English installation manual
O	Polish installation manual
P	Portuguese installation manual
S	Spanish installation manual
W	Swedish CE requirements document and English installation manual
C	Czech installation manual
B	Hungarian CE requirements document and English installation manual
K	Slovak CE requirements document and English installation manual
T	Estonian CE requirements document and English installation manual
U	Greek CE requirements document and English installation manual
L	Latvian CE requirements document and English installation manual
V	Lithuanian CE requirements document and English installation manual
Y	Slovenian CE requirements document and English installation manual
Code	Calibration options
Z	0,10% mass flow and 0,5 kg/m ³ density
Code	Measurement application software
Z	No measurement application software
Code	Factory options
Z	Standard product
X	ETO product
Typical Model Number: CMFHC3M 801 N 2 E Z E Z Z Z	

Ordering information *continued*

Super Duplex models

Model	Product description
CMFHC3Y	Micro Motion Coriolis ELITE sensor; 200 to 250 mm; Super Duplex
Code	Process connections
###	See process fitting options on pages 13–15.
Code	Case options
N	Standard pressure containment
Code	Electronics interface
0	Model 2400S transmitter
1	Extended mount Model 2400S transmitter
2	4-wire polyurethane-painted aluminum integral core processor for remote mount transmitters
3	4-wire stainless steel integral core processor for remote mount transmitters
4	4-wire polyurethane-painted aluminum integral extended mount core processor for remote mount transmitters
5	4-wire stainless steel integral extended mount core processor for remote mount transmitters
Code	Conduit connections
	Electronics interface codes 0 and 1
A	No gland
	Electronics interface codes 2, 3, 4, and 5
B	1/2-inch NPT — no gland
E	M20 — no gland
F	Brass/nickel cable gland (cable diameter 8,5 to 10 mm)
G	Stainless steel cable gland (cable diameter 8,5 to 10 mm)
Code	Approvals
	Electronics interface codes 0 and 1
M	Micro Motion Standard (no approval)
N	Micro Motion Standard / PED compliant
2	CSA Class I, Div. 2
V	ATEX Equipment Category 3 (Zone 2) / PED compliant
3	IECEX Zone 2
	Electronics interface codes 2, 3, 4, and 5
M	Micro Motion Standard (no approval)
N	Micro Motion Standard / PED compliant
A	CSA C-US (U.S.A. and Canada)
Z	ATEX Equipment Category 2 (Zone 1) / PED compliant
I	IECEX Zone 1
6	ATEX Equipment Category 2 (Zone 1 – IIC modified) / PED compliant
7	IECEX Zone 1 – IIC modified
Continued on next page	

Ordering information *continued*

Super Duplex models

Code	Language
A	Danish CE requirements document and English installation manual
D	Dutch CE requirements document and English installation manual
E	English installation manual
F	French installation manual
G	German installation manual
H	Finnish CE requirements document and English installation manual
I	Italian installation manual
J	Japanese installation manual
M	Chinese installation manual
N	Norwegian CE requirements document and English installation manual
O	Polish installation manual
P	Portuguese installation manual
S	Spanish installation manual
W	Swedish CE requirements document and English installation manual
C	Czech installation manual
B	Hungarian CE requirements document and English installation manual
K	Slovak CE requirements document and English installation manual
T	Estonian CE requirements document and English installation manual
U	Greek CE requirements document and English installation manual
L	Latvian CE requirements document and English installation manual
V	Lithuanian CE requirements document and English installation manual
Y	Slovenian CE requirements document and English installation manual
Code	Calibration options
Z	0,10% mass flow and 0,5 kg/m ³ density
Code	Measurement application software
Z	No measurement application software
Code	Factory options
Z	Standard product
X	ETO product
Typical Model Number: CMFHC3Y 825 N 2 E Z E Z Z Z	

Ordering information *continued*

High-temperature models

Model	Product description
CMFHC2A	Micro Motion Coriolis ELITE sensor; 150 to 200 mm; high temperature; 316L stainless steel
CMFHC3A	Micro Motion Coriolis ELITE sensor; 200 to 250 mm; high temperature; 316L stainless steel
Code	Process connections
###	See process fitting options on pages 13–15.
Code	Case options
N	Standard pressure containment
Code	Electronics interface
0	Model 2400S transmitter
2	4-wire polyurethane-painted aluminum integral core processor for remote mount transmitters
3	4-wire stainless steel integral core processor for remote mount transmitters
Code	Conduit connections
	Electronics interface codes 0 and 1
A	No gland
	Electronics interface codes 2, 3, 4, and 5
B	1/2-inch NPT – no gland
E	M20 – no gland
F	Brass/nickel cable gland (cable diameter 8,5 to 10 mm)
G	Stainless steel cable gland (cable diameter 8,5 to 10 mm)
Code	Approvals
	Electronics interface codes 0 and 1
M	Micro Motion Standard (no approval)
N	Micro Motion Standard / PED compliant
2	CSA Class I, Div. 2
V	ATEX Equipment Category 3 (Zone 2) / PED compliant
3	IECEX Zone 2
	Electronics interface codes 2, 3, 4, and 5
M	Micro Motion Standard (no approval)
N	Micro Motion Standard / PED compliant
A	CSA C-US (U.S.A. and Canada)
Z	ATEX Equipment Category 2 (Zone 1) / PED compliant
1	IECEX Zone 1
6	ATEX Equipment Category 2 (Zone 1 – IIC modified) / PED compliant
7	IECEX Zone 1 – IIC modified
Continued on next page	

Ordering information *continued*

High-temperature models

Code	Language
A	Danish CE requirements document and English installation manual
D	Dutch CE requirements document and English installation manual
E	English installation manual
F	French installation manual
G	German installation manual
H	Finnish CE requirements document and English installation manual
I	Italian installation manual
J	Japanese installation manual
M	Chinese installation manual
N	Norwegian CE requirements document and English installation manual
O	Polish installation manual
P	Portuguese installation manual
S	Spanish installation manual
W	Swedish CE requirements document and English installation manual
C	Czech installation manual
B	Hungarian CE requirements document and English installation manual
K	Slovak CE requirements document and English installation manual
T	Estonian CE requirements document and English installation manual
U	Greek CE requirements document and English installation manual
L	Latvian CE requirements document and English installation manual
V	Lithuanian CE requirements document and English installation manual
Y	Slovenian CE requirements document and English installation manual
Code	Calibration options
Z	0,10% mass flow and 0,5 kg/m ³ density
Code	Measurement application software
Z	No measurement application software
Code	Factory options
Z	Standard product
X	ETO product
Typical Model Number: CMFHC3A 801 N 2 E Z E Z Z Z	

Micro Motion—The undisputed leader in flow and density measurement



World-leading Micro Motion measurement solutions from Emerson Process Management deliver what you need most:

Technology leadership

Micro Motion introduced the first reliable Coriolis meter in 1977. Since that time, our ongoing product development has enabled us to provide the highest performing measurement devices available.

Product breadth

From compact, drainable process control to high flow rate fiscal transfer—look no further than Micro Motion for the widest range of measurement solutions.

Unparalleled value

Benefit from expert phone, field, and application service and support made possible by more than 600000 meters installed worldwide and over 30 years of flow and density measurement experience.

 www.micromotion.com

© 2011 Micro Motion, Inc. All rights reserved.

The Emerson logo is a trademark and service mark of Emerson Electric Co. Micro Motion, ELITE, ProLink, MVD and MVD Direct Connect are marks of one of the Emerson Process Management family of companies. All other trademarks are property of their respective owners.

Micro Motion supplies this publication for informational purposes only. While every effort has been made to ensure accuracy, this publication is not intended to make performance claims or process recommendations. Micro Motion does not warrant, guarantee, or assume any legal liability for the accuracy, completeness, timeliness, reliability, or usefulness of any information, product, or process described herein. We reserve the right to modify or improve the designs or specifications of our products at any time without notice. For actual product information and recommendations, please contact your local Micro Motion representative.

Emerson Process Management Micro Motion Americas

Worldwide Headquarters
7070 Winchester Circle
Boulder, Colorado USA 80301
T: +1 800 522 6277
T: +1 (303) 527 5200
F: +1 (303) 530 8459
Mexico T: 52 55 5809 5300
Argentina T: 54 11 4837 7000
Brazil T: 55 15 3238 3527
Venezuela T: 58 26 1792 1858

Emerson Process Management Micro Motion Europe/Middle East

Central & Eastern Europe T: +41 41 7686 111
Dubai T: +971 4 811 8100
France T: 0800 917 901
Germany T: 0800 182 5347
Italy T: 8008 77334
The Netherlands T: +31 318 495 555
Belgium T: +32 2 716 77 11
Spain T: +34 913 586 000
U.K. T: 0870 240 1978
Russia/CIS T: +7 495 981 9811

Emerson Process Management Micro Motion Asia Pacific

Australia T: (61) 3 9721 0200
China T: (86) 21 2892 9000
India T: (91) 22 6662 0566
Japan T: (81) 3 5769 6803
Korea T: (82) 2 3438 4600
Singapore T: (65) 6 777 8211

For a complete list of contact information and web sites, please visit: www.emersonprocess.com/home/contacts/global

