



Discontinuation Notification

To: Global Micro Motion Customers
cc: Global Micro Motion Sales
From: Tonya Wyatt
Date: June 25, 2010
Subject: Product Discontinuance – Analog RFT9739 Rack and Field Mount Transmitters

Dear Valued Customer:

Since the early 1990's, Emerson's Micro Motion Analog RFT9739 transmitters have successfully served in tens of thousands of flow applications all over the world. However, after almost 20 years, we are now faced with obsolescence of critical parts from our suppliers forcing us to discontinue the Analog RFT9739 product line.

In 2001, Emerson introduced the benefits of digital signal processing technology to the Coriolis market with the release of Micro Motion MVD™ Technology (multivariable digital) transmitters. Today, with the Series 1000, 2000, 3000 and the recently introduced Models 2200 and 2400 transmitters, customers are experiencing the benefits and superior functionality of MVD technology in thousands of installed flow applications worldwide.

At this time, Emerson is pleased to announce the introduction of a migration path allowing transition of RFT9739 Analog electronics to a digital signal processing based electronics. This migration path allows our customers to experience the benefits of MVD digital signal processing electronics, while protecting, and enhancing, their installed investment in Micro Motion flow solutions.

Micro Motion MVD Technology provides backwards compatibility to any existing 9-wire sensor, and also offers a range of inherent features and benefits that will further enhance the performance of your Micro Motion Coriolis meters:

- ✓ Improved accuracy
- ✓ Greater turndown
- ✓ Better performance in noisy applications
- ✓ Improved response time

When will Analog RFT9739 sales discontinue?

Orders for the Analog RFT9739 transmitters will be accepted through September 1, 2010, and shipments will be completed by October 1, 2010. Orders placed after September 1, 2010 will be fulfilled with other higher value MVD Technology transmitter options.

What are the options for the replacement?

Replacing an existing Analog RFT9739-Field Transmitter (RFT9739D/E)

The Micro Motion 9739 with MVD provides a simple and cost effective electronics module upgrade solution compatible with any 9-wire Micro Motion sensor. **The 9739 with MVD upgrade kit will provide a direct replacement of the Analog RFT9739 electronics module while using the existing electronics housing, wiring and conduit connections.** It is a plug and play replacement with the same inputs and outputs and the identical wiring distances as the Analog RFT9739 transmitter. Additionally, it completely replaces all of the electronic components of the existing transmitter including the power supply. Alternatively, a Model 2700 MVD transmitter could be used to replace the existing analog RFT9739 (see page 3).

Replacing an existing Analog RFT9739-Rack Transmitter (RFT9739R)

If you would like to continue to have your electronics installed in a control room, Emerson offers the Micro Motion Model 3500 MVD transmitter (Rack mounted with display) as well as Model 2500 MVD transmitter (DIN Rail mounted without display). Either option will require the addition of a core processor which can be remotely mounted to an existing Micro Motion 9-wire sensor (see page 4).

What is the support plan for the existing installed base?

Since the introduction of digital signal processing within the MVD electronics, customers have told us that the benefits of MVD transmitters are significant. It is recommended that any failed unit be replaced by an alternative Micro Motion MVD transmitter. However, in line with our general Micro Motion policy, we will support spare parts and field repairs to existing analog RFT9739 field mount transmitters until September 2011, or while supplies last. The RFT9739 rack mount transmitters will be supported with spare parts and field repairs for 5 years (July 2015).

Support life for the field mount units is limited to 1 year due to the complete migration path and limited supplies. After this period, the transmitters must be upgraded to MVD (see pages 3-4). *Note: Any installed 7-wire sensors (built before April 1988) need to be upgraded to support MVD Technology.*

If you have questions or would like to discuss a migration strategy for your installed base, please contact your local sales representative. We are happy to support you in every aspect.

Thank you for your continued business.

Tonya Wyatt
Product Line Business Manager

Option 1

Replacement of RFT9739E/D (field mount version) with 9739 with MVD Technology

Existing Sensor (9-wire)

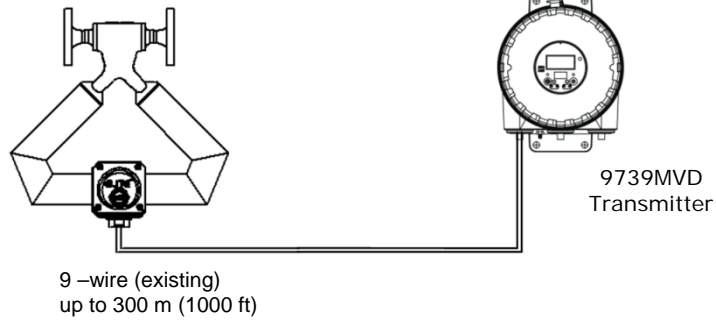

A **retrofit kit** can be used if:

- the existing transmitter model number starts with RFT9739D4, RFT9739D5, RFT9739E4, or RFT9739E5
- the existing transmitter serial number begins with 17, 18, 2, or 7.

A **complete transmitter** is required if:

- the existing transmitter model number starts with RFT9739E1, RFT9739E2, or RFT9739E3
 - the existing transmitter serial number begins with 15.
-

Option 2

Replacement of RFT9739E/D (field mount version) with 2700 with MVD Technology

Existing Sensor (9-wire)

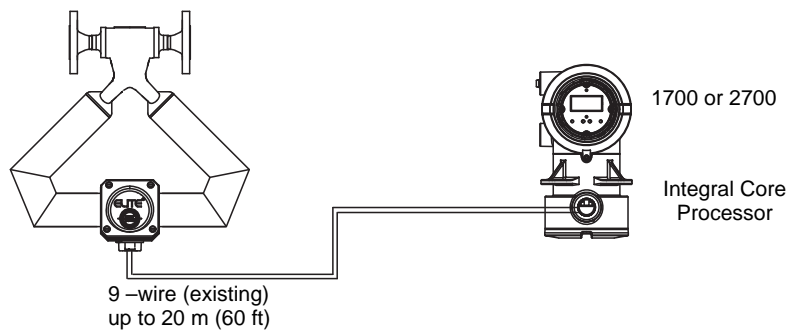

Option 3

Replacement of RFT9739R (Rack mount version) with 2500 with MVD Technology

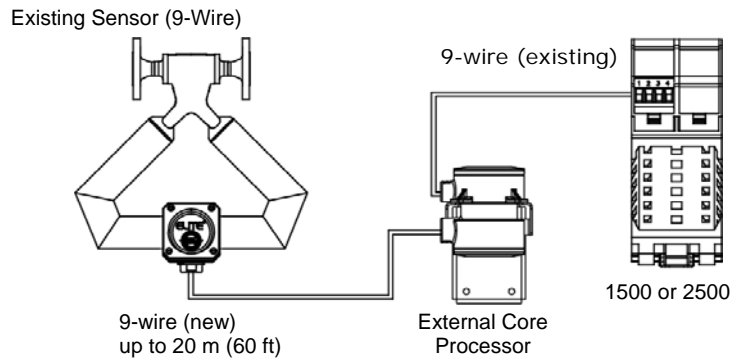

Option 4

Replacement of RFT9739R (Rack mount version) with 3500 with MVD Technology

(offered with an optional extender unit to ensure connection compatibility with the existing rack)

