

Issued by	NMi Certin B.V.
In accordance with	<ul style="list-style-type: none">– WELMEC guide 8.8 “General and Administrative Aspects of the Voluntary System of Modular Evaluation of Measuring instruments under the MID”;– WELMEC guide 7.2 “Software Guide”;– OIML R117-1 Edition 2007 (E) “Dynamic measuring systems for liquids other than water”;– OIML R137-1 Edition 2006(E) “Gas meters”.
Producer	Emerson Process Management Flow B.V. Neonstraat 1 6718 WX Ede The Netherlands
Measuring instrument	<p>A flow transmitter (calculator/indicating device for Micro Motion Coriolis meters), intended to be used as a part of a measuring instrument.</p> <p>Brand : Micro Motion Designation : 700; 800; 1700; 2500; 2700; 3500 and 3700 (“MVD Series”)</p> <p>Software version : see paragraph 1.2 of the description Accuracy class : 0,3 Environment classes : see paragraph 1.2 of the description Temperature range ambient : see paragraph 1.2 of the description</p> <p>Further properties are described in: – Description TC7057 revision 9 – Documentation folder TC7057-7</p>
Remarks	<ul style="list-style-type: none">– An overview of performed tests is given in Annex 1 TC7057 revision 9.– A description of the model identification codes on the manufacturer identification plate is given in Annex 2 belonging to this Evaluation certificate.– This revision 9 replaces the earlier versions, including its documentation folder.

Issuing Authority **NMi Certin B.V.**
17 May 2011

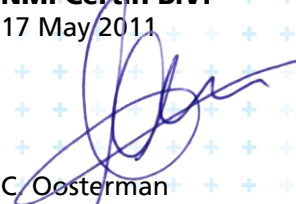

C. Oosterman
Head Certification Board

NMi Certin B.V.
Hugo de Grootplein 1
3314 EG Dordrecht
The Netherlands
T +31 78 6332332
certin@nmi.nl
www.nmi.nl

This document is issued under the provision that no liability is accepted and that the applicant shall indemnify third-party liability.

The designation of NMi Certin BV.as Notified Body can be verified at <http://ec.europa.eu/enterprise/newapproach/nando>

Parties concerned can lodge objection against this decision, within six weeks after the date of submission, to the general manager of NMi (see www.nmi.nl).

Reproduction of the complete document only is permitted.

1 General information on the flowtransmitter

- All properties of this flowtransmitter, whether mentioned or not, shall not be in conflict with the Legislation.
- This Evaluation certificate is the positive result of the applied voluntary, modular approach, for a component of a measuring instrument, as described in WELMEC guide 8.8.
- The complete measuring instrument must be covered by an EC type-examination certificate.

This revision 9 was issued due to the addition of:

- Software version 3.12 for MVD 700 core processor;
- Revised MVD 1700/2700 analog board;
- Welmec 7.2 software evaluation report.

The Evaluation certificate is valid for the Micro Motion flow transmitters, as described in paragraph 1.1 of the description, and may only be used in combination with Coriolis measurement sensors manufactured by Micro Motion:

- that are covered by an Evaluation certificate;
- directly mentioned in the EC type-Examination certificate of the measuring system.

The flow transmitter is intended for control of a Coriolis sensor and processing of its Custody Transfer output signals into:

- mass flow rate, mass total and mass inventory;
- actual density, actual volume flow rate, actual volume total and actual volume inventory;
- density at defined reference temperature, volume flow rate at defined reference temperature, volume total at defined reference temperature and volume inventory at defined reference temperature;
- net mass flow rate, net mass total, net mass inventory, net volume flow rate, net volume total, net volume inventory, and concentration.

Note: net means at defined reference temperature and 100% concentration.

Depending on the type, the flowtransmitter is equipped with a display or not and can be considered as an electronic calculator / indicating device or an electronic calculator.

Equipment connected to the transmitter's output can be applied to determine the volume under reference conditions and to generate indications and printouts of the measured/calculated quantities.

The MVD series consist of a processor module and a transmitter module, which can have the following configurations:

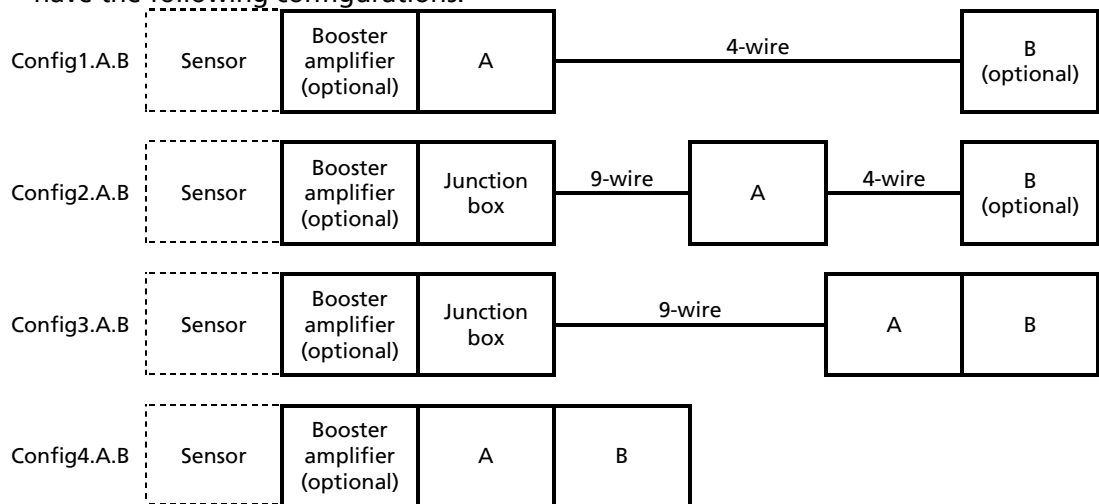

- With A and B being numbers, where:
- A is indicating the Core-Processor (see below).
- B is indicating the transmitter (see below).

1.1 Essential Parts

- **Booster amplifier**
 The booster amplifier is a mandatory part of the flowtransmitter if connected to a CMF400 sensor with a serial number below 411000 (See Evaluation certificate number TC7056, paragraph 1.2 for details) and DS600.
 In all other cases, the booster amplifier is optional.
- **The Core-Processor**
 The Core-Processor performs all measurements and calculations and makes the results available to the connected indicating module.
 The following models of Core-Processors are possible
 - MVD700, see chapter 2.1 (A=1).
 - MVD800, see chapter 2.2 (A=2)
- **Transmitter module**
 The transmitter module converts the digital data from the Core-Processor into output signals (for example current output, pulse output).
 The following models of indicating devices are possible:
 - MVD 1700 / MVD 2700, see paragraph 2.3 (B = 1).
 - MVD 2500, see paragraph 2.4 (B = 2).
 Remark: The MVD 2500 can only be used in Config1 and Config2 as mentioned in paragraph 1.
 - MVD 3500 / MVD 3700, see paragraph 2.5 (B = 3).
 Remark: The MVD 3500 and MVD 3700 can only be used in Config1 and Config2 as mentioned in paragraph 1.
- **Dual pulse converter (optional)**

A pulse converter, model 510, can be connected to the transmitter module MVD 2500/2700, which converts the two 90° shifted outputs pulses of the MVD 2500/2700 to two 180° shifted output pulses with the same frequency. The pulse width is adjustable.

- External calculator/indicating device (flow computer) (optional)
 An external calculator/indicating device (flow computer) can be connected to the flowtransmitter. The flowcomputer can be connected to:
 - The transmitter module using the available outputs of the transmitter module.
 - Directly to the Core processor using the MODbus input and output of the Core Processor. This case is indicated with B = 0.
 The flow computer has to be covered by an Evaluation certificate or has to be laid down in the EC Type-Examination certificate of the measuring instrument.

1.2 Essential Characteristics

- Software and environmental specification

Part	Version numbers	Environmental classes	Temperature range ambient
MVD700	2.0, 2.1, 2.2, 2.3, 2.4, 2.5, 2.6, 2.7, 2.8, 3.0, 3.1, 3.12 3.0 – ETO 17153	E3/M3	-25°C / +55°C
MVD800	3.21, 3.30, 3.40, 3.42, 3.50, 3.52, 3.60, 3.7 3.61 – ETO17170	E3/M3	
MVD 1700 / MVD 2700	3.2, 3.3, 3.4, 3.4.1, 3.5.3, 3.6, 3.7, 4.1, 4.2, 5.00/1.0, 5.12/1.0, 5.20/1.0, 6.0/1.1, 6.1/1.2	E3/M3	-25°C / +55°C
MVD2500	4.0, 4.1, 4.2, 5.00/1.0, 5.12/1.0, 5.20/1.0, 6.0/1.1, 6.1/1.2	E2/M2	
MVD3500 / MVD3700	7.0/1.1, 7.1/1.1, 7.2/1.1, 8.0/1.2	E3/M3	-40°C / +55°C

- Minimum measured quantity
 The minimum measured quantity is not smaller than the largest of the following values:
 - The minimum measured quantity of the connected sensor
 - 200 times the unit of indication of the 1700/2700/3500/3700 (being 0,001 ton or kg respectively 0,001 m³ or litres; see point 1.5)
 - 200 times the unit of indication of a connected additional electronic calculator/indicating (flow computer) device, if applicable.
 - 200 times the unit of printing, if applicable
- Custody Transfer parameters
 The Custody Transfer parameters and the mandatory settings are given in paragraph 1.5 of this Description.

- Security mode:
The 700/800 and 1700/2500/2700/3500/3700 have their own fixed ID number. After finalising the parameter settings in the models, the software is set in a secure mode, which means that an XOR operation is made based on both ID's to avoid exchanging modules. At the same time, the CRC checksum based on the configured parameters within the core-processor is stored within model 1700, 2500, 2700, 3500 or 3700 to avoid changing parameters within the core-processor ("marriage of core processor and transmitter").
- Marriage of a core processor to a transmitter is done by software with 1700/2500/2700 and by a hardware switch with 3500/3700. When MVD is in security mode, parameters declared as secured cannot be changed.
- Totals/inventories:
Only actual mass total/inventory, actual volume total/inventory, or standard/net (API/C.M.) volume total/inventory can be used to measure a custody transfer transaction. These totalisers/inventories can be read from the transmitter via the display (if configured as such), via pulse output (double channel, phase shifted) or via digital communication (MODbus).

1.3 Essential Shapes

- Inscriptions
 - At least the inscription "TC7057" is placed on the models mentioned in paragraph 1.1.
 - Identification of the measurement sensor.
 - Close to the display of the 1700, 2700, 3500 and 3700 or (if applicable, see paragraph 1.6) that of the connected flow computer: the minimum measured quantity.
- Status output
In case an electronic calculator/indicating device is connected to the 700, 800, 1700, 2500, 2700, 3500 or 3700 the status is sent to the connected device in the following ways:
 - The status is sent directly to the flow computer using the MODbus connection. Applicable for models 700, 800, 1700, 2700, 3500 and 3700.
 - The status output results in interrupting one of the pulse-channels, thus enabling the flow computer to detect a pulse failure and consequently generate an alarm. Applicable for models 2500 and 2700.
 - The MVD status results in a saturated mA output (< 3,6 mA or >21mA) thus enabling the flow computer to detect a failure and generate an alarm. Applicable for models 1700, 2500, 2700, 3500 and 3700.
- Sealing.
See chapter 4 of this description.

1.4 Conditional Parts

- Back-up EEPROM
The flow transmitter is provided with EEPROM's for the storage of non-volatile data, in case of power failure.
 - The EEPROM of the Core Processor stores the settings necessary to perform the measuring operation.
 - The EEPROM of the transmitters stores the setting of the outputs of the transmitter.
- Safety barrier
Optionally a safety barrier "MVD DIRECT CONNECT", model 3600663 is placed between the core processor and the external calculator/indicating device (flow computer).
- Push-Pull Opto Coupler (optional)
Optionally a push-pull opto-coupler is placed between the transmitter module and the external calculator/indicating device (flow computer) for the transmission of pulses over a large distance.
The Opto-coupler is of type Phoenix DEK-OE-...xxDC/100KHZ-G or any equivalent

1.5 Conditional Characteristics

- Indications (only applicable for 1700/2700):
 - Software version 3.2: the indication of the mass or volume has 8 characters with standard four decimals (format xxxx.xxxx). When the value 9999.9999 is reached the decimal point is shifted one position to the right (format becomes xxxxx.xxx). When the value 99999.999 is reached, the totaliser continues with indication 0000.0000 (rollover) without creating a "roll-over alarm".
 - Software version 3.3 and higher gives the possibility to select 0 to 4 digits behind the decimal point for the resettable totalisers only.
 - Software versions 3.3 and higher are equipped with a resetting feature (via display and digital communication) for the totals.
 - Software version 5.00/1.0 and higher gives the possibility to configure the display precision of each process variable (0 to 5 decimal digits) and the display update rate.
 - Software version 5.00/1.0 and higher is equipped with four options for resetting the totals: None, via display, via digital communication or via display and digital communication.
- The indication unit can be set on tons or kg respectively m³ or litres.
- The configuration of Custody Transfer parameters of the MVD must comply with what is given below:



Description

Number **TC70057** revision 9
Project number 11200214
Page 6 of 14

- Settings for the security mode
 - Custody transfer mode for models 1700, 2500 or 2700
 - Setting the system into Custody transfer mode required two steps:
 - Enabling: register 5000: code 3 for 1700 and code 1 for 2500/2700
 - Marrying 700/800 with 1700/2500/2700: via special software program or register 5003: code 7070.
 - Note: For 1700/2500/2700 only: Software version 3.3 and higher has the following extra function:
Placing the device from the secured state to the unsecured state will now restore the polling address on the connected core processor to 1 (default). Placing the device back into the secure state will change the core processor polling address once again.
See Emerson document TB13-02 Rev. 0 for more details on the software changes.
 - Custody transfer mode for models 3500 or 3700
 - Setting the system into Custody transfer mode required two steps:
 - Enabling register 5000: code 1;
 - Marrying 700/800 with 3500/3700: via security switch.
- From software version 3.5.3 (only applicable for 1700/2500/2700):
 - Gives the possibility to view the life zero on the MVD display
 - Allow the totalisers to be reset via HART when flow is zero and secure mode is enabled.

See Emerson document TB06-03 Rev. 0 for more details on the software changes.
- From software version 3.6 (only applicable for 1700/2500/2700):
 - Issued primary to provide a definitive means for customers with blind MVD transmitters to determine the exact software revision, since only display has the resolution to show more than the 10's digit of a version number (e.g. v3.53 shows as v3.53 on the display, but as v3.5 in HART and MODbus).

See Emerson document TB17-03 Rev. 0 for more details on the software changes.
- From software version 5.00/1.0 (only applicable for 1700/2500/2700):
 - Separation of the Custody Transfer mode through the World Area Selection. Selectable is NTEP (all parameters secured) and OIML (only W&M parameters secured).
 - Frequency output can be set to a simulation mode. Only if the instrument is not in Custody transfer mode (requires breaking of a seal).

See Emerson document TBFY07-002 Rev. A for more details on the software changes.
- From software revision 6.0 (only applicable for 1700/2500/2700):
 - Added the feature Field Verification Zero as one of the standard selections for the display process screen (requires software version 3.0 or higher for 700CP and version 3.5 or higher for 800ECP).
 - Added the feature Last Measured Value/Time-out to alarm A115 (external P-and/or T-transmitter are not responding).
 - Added the correction temperature (TCORR) to the API corrected volume flow screen, API corrected volume total and inventory screen, corrected density screen and CTL screen.

- Low flow cut off settings
The low flow cut off for mass flow and the low flow cut off for volume flow shall not be more than one fifth of the minimum flow rate of the connected sensor.
- Density cut off (only applicable to the 700)
 - Software version 2.0: the volume still shows a live value when density falls below the density cut off.
See Emerson document TB01-02 Rev. 1 for more details on the software changes.
 - Software version 2.1 and higher: the volume flow indicates zero when density falls below the density cut off.
See Emerson document TB06-03 Rev. 0 for more details on the software changes.
- Damping settings
 - Flow: maximum damping time is 1.6 s.
 - Density: maximum damping time is 1.6 s.
 - Temperature: maximum damping time is 4.8 s.
- Slug flow settings
The maximum slug flow duration is 2 s.
- Last measured value fault time out settings
The maximum last measured value fault time out setting for mA and for pulses (one setting) 2 s.

1.6 Conditional Shapes

- Printed Ticket (if applicable)
 - See the Evaluation certificate of the applied flow computer if the printer is connected to the flow computer.
 - In case a printer is connected to the 3500/3700, at least the following information is printed:
 - Unique information, identifying the delivery.
 - Delivered mass and/or volume under metering conditions.
 - Identification of the delivered product.
 - A message indicating if alarms have occurred during the delivery.Optionally the following information can be printed:
 - Delivered volume under reference conditions, In this case it is mandatory to print the reference conditions.

1.7 Non essential parts

- Bunker manifold switch.
Only present in case of the marine bunkering application. Determines if the valve (transfer point) is open or closed.
- Two warning lights to indicate the aeration level of the ongoing batch.

1.8 Non essential Shapes

- Optionally the display is equipped with a backlight.

2 Information about the main essential parts of the flowtransmitter.

2.1 MVD700 Core-Processor

2.1.1 Essential parts

See the documentation folder, section MVD700.

2.1.2 Essential characteristics

- Inputs to the MVD700
 - Two pick-off signals, analogue millivolt signals from which the mass flow and the density are determined.
 - One three-wire PT-100 temperature input for measurement of the sensors tube temperature.
Note: this temperature may not be used for converting actual volume to a volume at standard temperature.
 - MODbus input for:
 - Pressure to correct the effect of the fluid pressure on the vibration characteristics of the measurement sensor.
 - Temperature for conversion of actual volume to standard volume.
Note: this temperature may also be used as the sensors tube temperature.
- Outputs of the MVD700
 - Alternating current to set the sensors tubes into vibration. The frequency of this current is controlled at the resonant frequency of the tubes.
 - MODbus for output of the various parameters (for example mass total) to an approved device (for example the transmitters mentioned in this Evaluation certificate).
- Provides the following functions:
 - Read – write access to the digital communication interface of all configuration data.
 - Stores the Flow Cal Factor (FCF) in non-volatile memory.
 - Stores the density calibration factors (K1, D1, K2, D2, and FD) in non-volatile memory.
 - Stores the temperature coefficients (slope, offset) in non-volatile memory.
 - Provides a calibration procedure for setting the mechanical zero and stores the result in non-volatile memory.
 - Stores damping factors for flow, density and temperature in non-volatile memory.
 - Provides configuration of units for mass flow, volume flow, density, pressure, and temperature.
 - Stores slug flow (density) limits and slug flow duration in non-volatile memory.
- Custody Transfer software
 - Mass determination:
The time shift between the two pick-off signals is representative for the mass flow of the fluid flowing through the connected measurement sensor. Mass flow is calculated with corresponding equation.
See Evaluation Certificate TC7056 for conditions on determining the Flow Temperature Coefficient (FT) of the individual sensor.
 - Density determination:



Description

Number **TC70057** revision 9
Project number 11200214
Page 9 of 14

The core-processor controls the measurements tubes in such a way that they vibrate with the resonant frequency. The resonant frequency is representative for the actual density in the sensor and is calculated with corresponding frequency. See Evaluation Certificate TC7056 for conditions on determining the Density Temperature Coefficient (DT) of the individual sensor.

- Volume determination:
From the measured mass and density, the core processor calculates the volume of the fluid flowing through the sensor.
See Evaluation Certificate TC7056 for conditions on determining the FT and DT Coefficient of the individual sensor.
- Volume conversion to reference conditions:
 - Volume conversion using API table's
 - * API table's 5A, 5D, 6C, 23A, 23D, 24C, 53A, 53D and 54C.
 - * With Core Processor version v2.5 and higher, also using API table's 5B, 23B or 53B.

The standard temperature is programmable when using table's 53A, 53B or 53D.
 - Using the concentration measurement feature for density and volume at a defined reference temperature for any liquid for which a traceable database or norm/standard is available. For example, Bio fuels.
Also, see Chapter 3.
The concentration measurement feature uses manually configured tables in the Core Processor. These tables are stored behind seal, e.g. they cannot be modified when the instrument is in Custody Transfer mode.
 - Concentration measurement feature for measuring alcohol, alcohol percentage and alcohol volume at 20 °C (100% alcohol).
For using the concentration measurement feature on alcohol, it is always (independent of temperature) necessary to determine the FT and DT values of the individual sensor.
 - When using volume conversion the temperature of the fluid has to be measured with an external temperature probe.
It is not allowed to use the temperature probe of the connected measurement sensor.
 - Volume conversion to reference conditions is not allowed in combination with the MVD 2500 transmitter
- Corrections
The MVD700 core processor automatically corrects for temperature effects on the sensor's measurement tubes, using the read-out of the sensor's internal temperature transmitter.
Software versions 2.1 and higher support an improved formula for temperature correction for temperatures lower than 0°C.
- If needed, depending on the size of the sensor, automatically correction for pressure can be applied via an external pressure transmitter using the digital communication protocol HART Bell 202.

- LD-compensation, software version 3.0-ETO17153 and software versions 3.1 or higher.
The LD-compensation shall be used when the flowtransmitter is connected to certain types of Micro Motion Coriolis sensors and measuring certain types of liquids. See documents TC7056/6-1 and TC7050/2-1 "LD compensation" for details.
The LD-control parameter has the following settings:
 - 0 = LD compensation is off
 - 1 = LD compensation using hard coded coefficients in the software. Each Coriolis sensor has its own unique set of coefficients
 - 2 = LD compensation using reference density and a set of programmable parameters
 - 3 = LD compensation using actual density and a set of programmable parametersThe LD-control parameter and subsequent parameters (for LD control = 2 or 3) are stored behind seal.

2.2 MVD800 Core-Processor

The MVD800 Enhanced Core Processor is mainly the same as the MVD700.

2.2.1 Essential parts

See the documentation folder, section MVD800.

2.2.2 Essential characteristics

- See the essential characteristics of the MVD700
- Additions of the MVD800 in respect to the MVD700:
 - Meter Verification (off-line) feature (only possible if the instrument is not in Custody Transfer mode, this requires breaking of the seal).
Meter verification is comparing the current sensor characteristics with the previously stored (initial) characteristics.
 - Smart Meter Verification (on-line), software version 3.60 or higher.
Can be used in Custody Transfer mode, as it has no influence on the measurement accuracy.
- Custody Transfer software
 - LD-compensation and marine bunkering application, software version 3.61-ETO17170 and software versions 3.7 or higher.
See the description of the LD-compensation in the description of the MVD700.
- The MVD800 Enhanced Core Processor can be changed with another MVD800.
 - This is under the condition that the Weights and Measures parameters from the old MVD800 are transferred to the new MVD800 and that the new MVD800 is zero-ed via the auto-zero function.
 - Exchanging the MVD800 Enhanced Core Processor requires breaking of the seal of the connected transmitter.

2.3 MVD 1700 / MVD 2700

2.3.1 Essential parts

See the documentation folder, section MVD2700.

- Power Supply
The MVD 1700 / MVD 2700 is equipped with a universal power supply, rating:
 - 85 – 265 V AC, 50 – 60 Hz; 18 – 100 V DC.
- Main electronics board
The main electronic board reads the parameters from the Core Processor and converts the results into various outputs.
There are 2 variants:
 - CONFIG I/O (not for the MVD 1700) (model code "2700***x***y*", x = B or C, y = W or D)
 - ANALOG BRD (model code "x700***A***y*", x = 1 or 2, y = W or D)
- Display with infra-red buttons (optional)
Measured variables and parameters can be viewed on the display, using two infrared buttons and a "menu" dialog system.

2.3.2 Essential characteristics

- Inputs of the MVD 1700 / MVD 2700
 - MODbus from the Core Processor
 - Optionally digital reading of pressure and/or temperature through the HART, BELL202 protocol over the current output.
The Hart signals are superimposed on the DC-current of the output.
- Outputs of the MVD 1700 / MVD 2700
 - In case of ANALOG BRD:
 - Current output for density
 - MODbus RS485 output of the various parameters (for example mass total) to an approved indicating device (flow computer)
 - In case of CONFIG I/O:
 - Double, phase shifted, pulse output for the transmission of mass- or volume-information (90°; 180° and quadrature with flow direction).
This output is also used as status output.
 - Current output for density.
- In case only the mass indication is a custody transfer value, the indication of the volume shall be prohibited or a label with the text "volume not to be used for custody transfer" is applied.

2.3.3 Conditional parts

- Housing
The housing is executed in different forms depending on the configuration (see diagram in point 1) and can be used in a hazardous area.

2.4 MVD 2500

2.4.1 Essential parts

See the documentation folder section MVD2500.

- Power supply
Ratings: 24 V DC
- CONFIG I/O
Reads the parameters from the Core Processor and converts the results into various outputs.

2.4.2 Essential characteristics

- Inputs of the MVD 2500
 - MODbus from the Core Processor
 - Optionally digital reading of pressure and/or temperature through the HART, BELL202 protocol over the current output.
The Hart signals are superimposed on the DC-current of the output.
- Outputs of the MVD 2500
 - Double, phase shifted, pulse output for the transmission of mass- or volume-information (90°; 180° and quadrature with flow direction).
This output is also used as status output.
 - Current output for density.
- The MVD 2500 has a combined MODbus output and service port. To gain access to the service port a "special" communication connection has to be made within 10 seconds after power up of the module. In order to prevent the unauthorised changes of parameters this port may not be physically wired when the module is in Custody Transfer mode.

2.5 MVD 3500 / MVD 3700

2.5.1 Essential parts

See the documentation folder section MVD3000.

- 4 wire Coriolis Card
Reads the parameters from the Core Processor and converts the results into various outputs via the application card.
- Power Supply
The MVD 3500 / MVD 3700 can be equipped with a power supply, with the following rating:
 - 85 – 265 V AC, 50 – 60 Hz or 18 – 100 V DC.
- Display
Backlit LCD, 128 x 128 pixel bitmap

2.5.2 Essential characteristics

- Inputs of the MVD 3500 / MVD 3700
 - MODbus from the Core Processor
 - Optionally digital reading of pressure and/or temperature through the HART, BELL202 protocol over the current output.
The Hart signals are superimposed on the DC-current of the output.
- Outputs of the MVD 3500 / MVD 3700
 - Two 4 – 20 mA outputs for the transmission of the density. The first current output can also read external temperature and/or pressure using HART, BELL202.
 - MODbus RS485 output of various parameters (e.g. mass total) to an approved indicating device (flow computer).
 - Printout of the delivery via RS485 port using the FDW-protocol.
Note 1: The RS485 port can be configured for MODbus output OR printer output.
Note 2: for the FDW-protocol, you need the FDW-controller/printer from Dohmann GmbH.
- The custody transfer value(s) is put between asterisks (e.g. *123456 * kg).
- Software version 8.0/1.2 and higher incorporates special features used when bunkering marine fuels (heavy fuel oils / bunker fuel):
 - Dedicated printout for bunkering. See example ticket in the documentation folder.
 - The amount of aeration (air inclusion in the fluid) is calculated from the measurement sensor signals, presented on screen (after MMQ has been delivered), and presented on the ticket.
 - Two warning levels are defined for aeration, the warning levels are programmable and settings are secured behind a seal.
If the amount of aeration exceeds the defined level:
 - A warning is displayed on the display.
 - And, if present, the corresponding warning light goes on.
 - One discrete input must be assigned to “read” the bunker manifold switch for open/close position.
 - Optionally, two discrete outputs are assigned to the aeration warning lights.
 - Acceptance criteria are added to the ticket and used to declare a batch valid or not.

3 Conditions for approval

- The use of this Evaluation Certificate is limited to:
 - Other parties may use this Evaluation Certificate only with the written permission of Emerson Process Management Flow B.V., Neonstraat 1, 6718 WX Ede, the Netherlands.
- Cabling
 - Cabling has to be in accordance with manufacturer installation instructions.
 - The use of the Micro Motion cable between the MVD700 and the MVD 2500 is mandatory.

- In case of using the concentration measurement feature, the initial verification must include the correctness of the configured table. This to verify that the conversion does not exceed the limits as defined for software calculations.

4 Seals

- After setting the model 1700 or 2700 in Custody Transfer mode, the access to the service port is sealed to avoid unauthorised changing of parameters.
See the documentation number 7057/00-18.
- After setting the model 2500 in custody transfer mode:
 - The connections to the service port must be removed and the connections sealed to avoid connecting to the service port. This sealing also prevents the MODbus from being used.
 - The housing in which the model 2500 is placed is sealed against unauthorised opening. This sealing prevents the changes to the wiring of the pulse output and the current output.
See the documentation number 7057/00-19.
- After setting the model 3500 or 3700 in Custody transfer mode:
 - The access to the security switch is prevented with a seal to avoid unauthorised changing of parameters.
 - In case of marine bunkering application: an additional seal is required to prevent bridging of the bunker manifold switch.
See the documentation number 7057/08-01.
- In case of marine bunkering application, the marine bunkering switch must be sealed against removal.
- If present, the housing in which the push-pull opto-coupler is placed is sealed against opening. This to prevent access to the wiring of the pulse output.
- For the seals of the connected electronic calculator/indicating device, if applicable, see the applicable Evaluation Certificate.

Performed tests on behalf of this Evaluation Certificate:

Test	Part	Type	Test report	Test house	Remarks
Software tests according to OIML R117	Flow transmitter	MVD	CVN201269-1	NMi Certin B.V.	-
Climate and EMC/CE related tests according R117	Flow transmitter	MVD	CVN201269-1	NMi Certin B.V. TNO Certification B.V.	Test procedure: monitoring a manually inputted mass ZERO value, the corresponding volume value and the pulse- and mA-output during test condition
CMF 400 sensor without booster amplifier	Sensor plus transmitter	CMF 400 and MVD	CVN-410178-4	NMi Certin B.V.	Tests performed at the test installation of Micro Motion in Veenendaal
Climate tests according R117	Transmitter	MVD 2500	CPC-307228-1	NMi Certin B.V.	Test procedure: monitoring a manually inputted mass ZERO value, the corresponding volume value and the pulse- and mA-output during test condition
EMC tests according R117	Transmitter	MVD 2500	CPC-307228-1	TNO EPS B.V.	Test procedure: monitoring a manually inputted mass ZERO value, the corresponding volume value and the pulse- and mA-output during test condition Tests are witnessed by NMi Certin B.V.
EMC tests according R117-1	Transmitter	MVD700 MVD2500 MVD1700/ MVD2700	CPC-607580-1	NMi Certin B.V.	Test procedure: monitoring a manually inputted mass ZERO value, the corresponding volume value and the pulse- and mA-output during test condition
Climate, Vibration and EMC tests according R117-1 and R137-1	Transmitter	MVD800 MVD2500 MVD1700/ MVD2700	CPC-610406-2	NMi Certin B.V.	Test procedure: monitoring a manually inputted mass ZERO value, the corresponding volume value and the pulse- and mA-output during test condition
%Alcohol measurements	Transmitter	MVD700 MVD2700 MVD3700	DDC/22/ G070447-D4	LNE	
Climate, EMC	Dual pulse converter	Model 510	07060402.emc	TÜV Rheinland Electronic Products & Services (EPS) BV	

Climate, EMC and vibration according R117-1 and R137-1	Transmitter	MVD3500 MVD3700	CPC-710466-1	NMi Certin B.V.	
LD Compensation / Aeration	Transmitter	MVD700 MVD800 MVD3500 MVD3700	[1]	NMi Certin B.V.	Theoretical tests and practical tests (bunkering)
Climate tests according to OIML R117-1	Transmitter	MVD1700	1700 Analog HART Temperature Test, 3 May 2011	Micro Motion	Modified analog board
EMC tests according R117-1	Transmitter	MVD2700	NMi-11200214-01	NMi Certin B.V.	Modified analog board
Software tests according to WELMEC Guide 7.2	Transmitter	MVD	NMi-11200214-02	NMi Certin B.V.	-

[1] The test results are stored in the technical file at NMI.

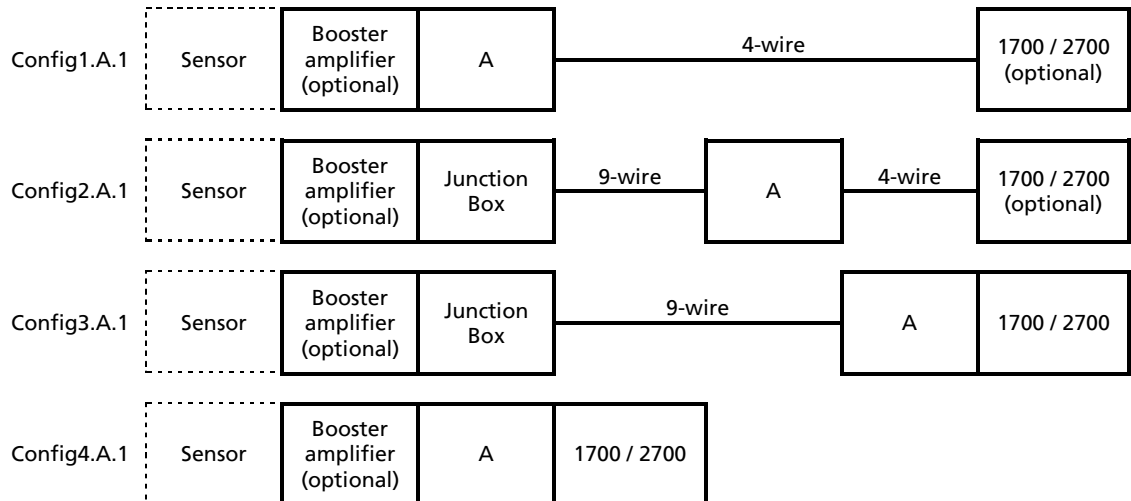

With A indicating the Core Processor (Model 700 or Model 800)

Transmitter Type a700bcdefghijk

- Pos a: 1 = Single Variable Transmitter (i.e. 1700)
 2 = Multi Variable Transmitter (i.e. 2700)
- Pos b: Mounting;
 R = 4 –wire remote mounting (Config1.A.1);
 B = 4-wire remote mounting with 9-wire remote core processor (Config2.A.1)
 C = 9-wire remote mounting (Config3.A.1)
 I = Integral mounted transmitter (Config4.A.1)
- Pos c: Power Supply. Option without influence on custody transfer approval
- Pos d: Display:
 1, 2, 4 and 5 = with Display;
 3 = without Display
- Pos e: Output options:
 A = ANALOG BRD (MVD1700 and MVD2700);
 B = Config. I/O BRD, factory default setting (MVD2700 only)
 C = Config. I/O BRD, dedicated to application (MVD2700 only)
- Pos f: Conduit connections: Option without influence on custody transfer approval
- Pos g: Ex-approvals: Option without influence on custody transfer approval
- Pos h: Language: Option without influence on custody transfer approval
- Pos i: Software options 1:
 Z = Flow & density variables (standard)
 A = Petroleum measurement (volume conversion) (MVD2700 only)
 G = concentration measurement (mass, density or volume conversion) (MVD2700 only).
 Note alternatively letter code Z is used with ETO number 09851 and 12767.
- Pos j: Software options 2
 W= Custody Transfer
 D = Custody Transfer and Meter verification (MVD800 only)

Pos k: Factory options: Option without influence on custody transfer approval

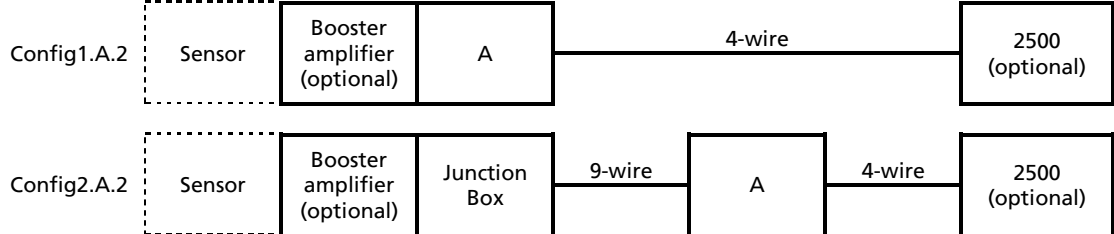

With A indicating the Core Processor (model 700 or Model 800)

Transmitter Type 2500abcdefghijkl

Pos a: Mounting;

B = 4-wire remote 35 mm DIN rail transmitter with 9 wire remote core processor (Config2.A.2);

D = 4-wire remote 35 mm DIN rail transmitter (Config1.A.2)

Pos b: Power Supply:

3 = 19.2 to 28.8 V DC

Pos c: Conduit connections: Option without influence on custody transfer approval

Pos d: Output options:

B = one mA; two configurable I/O channels; RS-485 – default configuration

C = one mA; two configurable I/O channels; RS-485 – custom configuration

Pos e: Terminals: Option without influence on custody transfer approval

Pos f: Approvals: Option without influence on custody transfer approval

Pos g: Language: Option without influence on custody transfer approval

Pos h: Software options 1:

Z = Flow & density variables (standard)

Note: option A (petroleum measurement (volume conversion)) is not allowed.

Pos i: Software options 2:

W= Custody Transfer

D = Custody Transfer and Meter verification (MVD800 only)

Pos j: Factory options: Option without influence on custody transfer approval

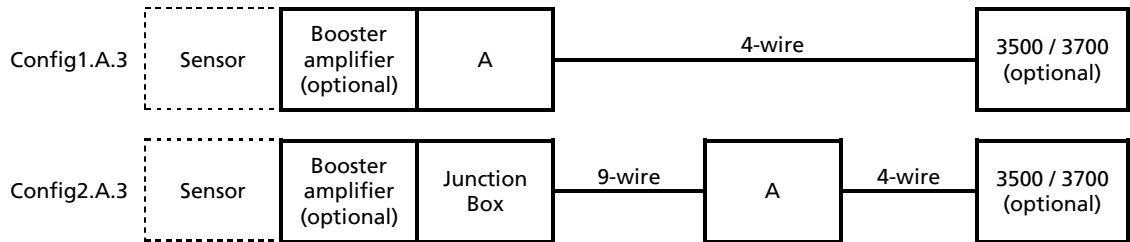

With A indicating the Core Processor (Model 700 or Model 800)

Transmitter Type 3500bcdefghijklm

Transmitter Type 3700bcdefg ijklm

- Pos b: Mounting options;
 - R = Din-rack mount (3500 only)
 - P = Panel mount (3500 only)
 - A = Field mount (3700 only)
- Pos c: Power Supply. Option without influence on custody transfer approval
- Pos d: Remote Core Processor. Option without influence on custody transfer approval
- Pos e: Additional hardware modules;
 - 2 = Weights & Measures Custody Transfer (OIML)
 - 3 = Marine Bunker Hardware
- Pos f: Sensor interface:
 - 5 = 4-wire interface to sensor with core processor (Config 1.A.3 only)
 - 6 = 4-wire remote mount transmitter with 9-wire remote core processor (Config 2.A.3 only)
- Pos g: Terminals. Option without influence on custody transfer approval
- Pos h: Relays and housing:
 - 1 = No relays and housing
- Pos i: Approvals. Option without influence on custody transfer approval
- Pos j: Language: Option without influence on custody transfer approval
- Pos k: Control application software: Option without influence on custody transfer approval
- Pos l: Measurement application software.
 - A = Petroleum measurement (volume conversion)
 - B = Concentration measurement predefined
 - G = Concentration measurement
 - Z = No measurement application software
- Pos m: Specialty applications:
 - Z = No specialty applications



Annex 2

Number **TC7057** revision 9
Project number 11200214
Page 4 of 4

Approved models code for the 3500 with CIC A2:

- 3500***2 [5 or 6]****[Z or D][Z, G, B or A]*
- 3500***2 [5 or 6]****[Z, C, D or E][Z, G, B or A]*
- 3500***35**** [F or H]Z*

with model 700
with model 800
with model 800

Approved models code for the 3700 with CIC A2:

- 3700***2 [5 or 6]***[Z or D][Z, G, B or A]*
- 3700***2 [5 or 6]***[Z, C, D or E][Z, G, B or A]*
- 3700***35*** [F or H]Z*

with model 700
with model 800
with model 800