

ERNG-X

TESCOM Product Manual

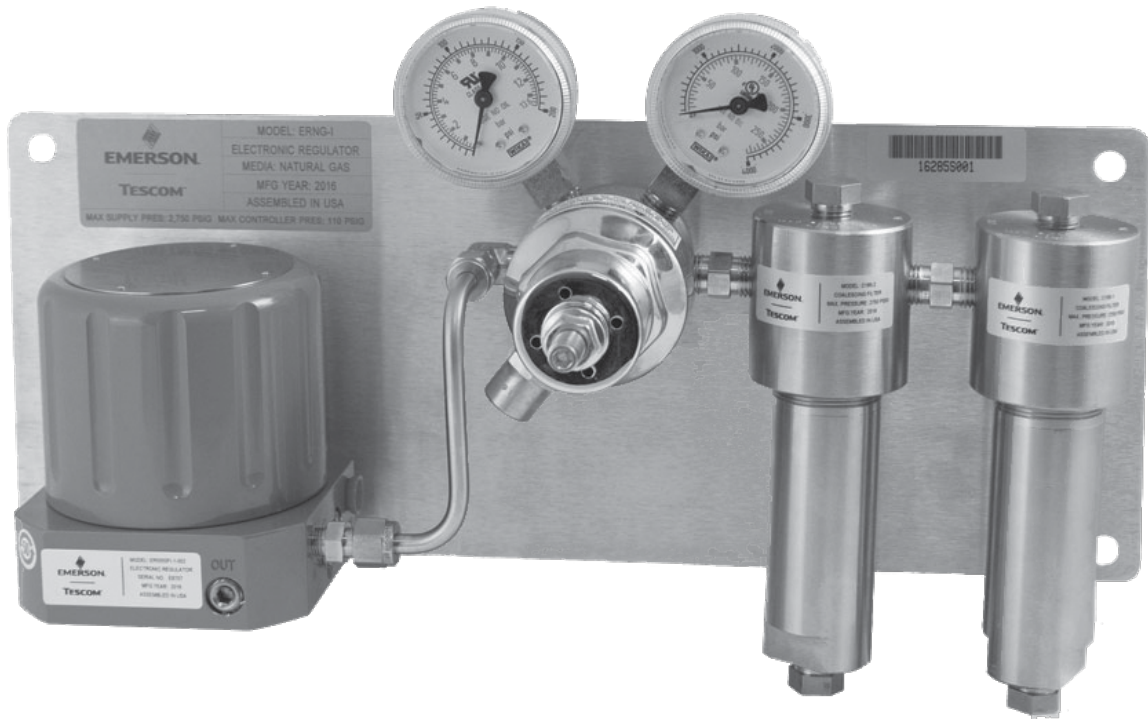

Figure 1. ERNG-X

Contents

Section 1: Introduction	2
Section 2: Before You Begin	2
2.1 Safety, Installation and Operations Precautions	3
2.1.1 TESCOM Electronic Controllers, Regulators and Filters	3
Section 3: Product Description	6
3.1 Features	6
3.1.1 Accurate Pressure Control	6
3.1.2 Automation	6
3.1.3 ERTune™ Program	6
3.1.4 Items Included	6
3.2 Controlling System Pressure	6
3.3 Specifications	7
Section 4: Installation	8
4.1 Installation Diagram	8
4.2 Mounting	8
4.3 Connect Pressure Lines	8
4.4 Wiring	8
4.5 Communication	9
4.6 System Leak Check	9
4.7 ERNG-X Tuning	9
4.8 Special Control Features Available	9
Section 5: Maintenance	10
5.1 Filter Maintenance	10
Section 6: Drawings	11
6.1 ERNG-X Dimensions	11
6.2 C195-X Filter Assembly	12

Section 1: Introduction

This manual is valid only for ERNG-X. The instructions for individual components must also be read and followed.

- ER5000 Getting Started (DOPSM2065XML2)
- ER5000 Series User Manual (DOPSM2064X012)
- Safety, Installation, Operations and Service Manual (DOPMS2080X012)

Section 2: Before You Begin

WARNING



-  Do not install, operate or maintain an ERNG-X or any associated equipment, without reading and fully understanding the installation guidelines and operating instructions for every component of your application. To avoid death, serious injury and/or property damage, it is important to carefully read, understand and follow all contents of this Product Manual, including all safety cautions and warnings. If you have any questions about these instructions, contact your TESCO sales office before proceeding.

Make sure that the components and materials used in the fluid handling system are compatible with the fluid and have the proper pressure rating. Failure to do so can result in death, serious injury and/or property damage. Inspect the regulator, valve and accessories for physical damage and contamination.

Do not connect the regulator, valve or accessory if you detect oil, grease or damaged parts. If the regulator, valve or accessory is damaged, contact your local TESCO representative to have the regulator cleaned or repaired.

Do not modify equipment or add attachments not approved by the manufacturer. Failure to follow can result in death, serious injury and/or property damage.

Before proceeding with any installation procedures:

- 
 - Always wear protective clothing, gloves and eyewear to prevent personal injury or property damage.
 - Do not remove the ERNG-X or any other individual component of the product while the system is pressurized.
- 
 - Disconnect any electric power or a control signal to the ERNG-X prior to installation or maintenance.
 - Disconnect any operating lines providing pressure to the ERNG-X prior to installation or maintenance.
 - Use bypass valves or completely shut off the process to isolate the ERNG-X and associated equipment from process pressure prior to installation, maintenance or removal.
- 
 - Use lock-out procedures to be sure that the above measures stay in effect while you work on the equipment.
 - Check with your process or safety engineer for any additional measures that must be taken to protect against process media dangers.

2.1 Safety, Installation and Operations Precautions

2.1.1 TESCOM Electronic Controllers, Regulators and Filters

⚠ WARNING

Do not attempt to select, install, use or maintain this controller or accessory until you have read and fully understood these instructions and the individual component instructions. Be sure this information reaches the operator and stays with the product after installation. Do not permit untrained personnel to install, use or maintain this controller or accessory. Improper selection, installation, maintenance, misuse or abuse of this controller or related accessories can cause death, serious injury and/or property damage.

Possible consequence include but are not limited to:

- **High velocity fluid (gas or liquid) discharge**
- **⚠ Electrocutation**
- **Parts ejected at high speed**
- **Contact with fluids that may be hot, cold, toxic or otherwise injurious**
- **Explosion or burning of the fluid**
- **Lines/hoses whipping dangerously**
- **Damage or destruction to other components or equipment in the system**

⚠ CAUTION

1. Read and understand the user's manual before operating the product.
2. Before each use, inspect the product for physical damage and contamination. Do not connect the controller or component if you detect oil, grease or damaged parts. If the product is damaged, contact your local TESCOM representative to have the product cleaned or repaired.
3. Operate the product only under specified environmental conditions.
4. Follow instructions in the manuals for proper wiring.
5. Never connect the product to a supply source having a voltage greater than the maximum rated voltage of this controller or accessory.
6. Never connect the product to a supply source having a pressure greater than the maximum rated pressure of this controller or accessory.
7. Start up sequence for electropneumatic controllers is:
 - a. Feedback loop must be installed and operational.
 - b. Electrical power should be applied and system setpoint reduced to its lowest pressure output before turning on the pneumatic supply to the ERNG-X controller.
8. Refer to product label (modification specific) for maximum inlet pressures. If this rated pressure cannot be found, contact your local TESCOM representative for the rated pressure prior to installation and use. Verify the designed pressure rating of all equipment (e.g., supply lines, fittings, connections, filters, valves, gauges, etc.) in your system. All must be capable of handling the supply and operating pressure.

9. Clearly establish flow direction of the fluid before installation of controllers, regulators, valves and accessories. It is the responsibility of the user to install the equipment in the correct direction.
10. Remove pressure from the system before tightening fittings, gauges or components.
11. Never turn controller, regulator or filters. Instead, hold the body and turn fitting nut.
12. If a controller, regulator or valve leaks or malfunctions, take it out of service immediately.
13. Apply pressure to the system gradually, to avoid a sudden surge of fluid or pressure shock to the equipment in the system.
14. Regulators are not shut-off valves. Install a pressure relief device downstream of the regulator to protect the process equipment from operating pressure increases. Shut off the supply pressure when the regulator is not in use.
15. Periodic inspection and scheduled maintenance of your equipment is required for continued safe operation.
16. The frequency of servicing is the responsibility of the user based on the application. Never allow problems or lack of maintenance to go unreported.
17. Read and follow precautions on compressed gas cylinder labels.
18. It is important that you analyze all aspects of your application and review all available information concerning the product or system. Obtain, read and understand the Material Safety Data Sheet (MSDS) for each fluid used in your system.
19. Never use materials for controllers, regulators, valves or accessories that are not compatible with the fluids being used.
20. Users must test under normal operating conditions to determine suitability of materials in an application.
21. Vent fluids to a safe environment and in an area away from employees. Be sure that venting and disposal methods are in accordance with Federal, State and Local requirements. Locate and construct vent lines to prevent condensation or gas accumulation. Make sure the vent outlet is not obstructed by rain, snow, ice, vegetation, insects, birds, etc. Do not interconnect vent lines; use separate lines if more than one vent is needed.
22. Do not locate regulators, valves or accessories controlling flammable fluids near open flames or any other source of ignition.
23. Some fluids, when burning, do not exhibit a visible flame. Use extreme caution when inspecting and/or servicing systems using flammable fluids to avoid death or serious injury to employees. Provide a device to warn employees of these dangerous conditions.
24. Many gases can cause suffocation. Make certain the area is well ventilated. Provide a device to warn employees of lack of Oxygen.
25. Never use oil or grease on these controllers, regulators, valves or accessories. Oil and grease are easily ignited and may combine violently with some fluids under pressure.
26. Have emergency equipment in the area if toxic or flammable fluids are used.
27. Do not bleed system by loosening fittings.
28. Prevent icing of the equipment by removing excess moisture from the gas.
29. Always use proper thread lubricants and sealants on tapered pipe threads.

⚠ WARNING

Complete system integration and design is the responsibility of the user. The following are suggested malfunction design considerations but is not an all inclusive list.

- Loss of ERNG-X controller power, loss of transducer power or loss of flow meter power
- Interrupted or lost communication exchange to ERNG-X controller
- Inlet solenoid malfunction leading to uncontrollable pressurization of spring case on pipeline pilot regulator
- Instability in system causing pressure swings
- Back flow of high pressure gas into ERNG-X controller control port, exhaust port or gauge port causing uncontrollable pressurization of the spring case of the pipeline pilot regulator and/or over pressurization of the pressure rating of the ERNG-X controller.
- Exhaust port corrosion from atmospheric salt and humidity
- Decaying inlet of supply regulator causing over pressurization to ERNG-X controller
- Spring case rating on pipeline pilot regulator

Special conditions for safe use of ER5050, see ER5000 Series User Manual (DOPSM2064X012) for complete ER5050 product capabilities:

- Rated for 20.5 to 28.5 VDC, 340 mA
- Maximum working pressure: 110 psig / 7.5 bar
- Temperature Range: $-20^{\circ}\text{C} \leq T_{\text{amb}} \leq 60^{\circ}\text{C}$ ($-4^{\circ}\text{F} \leq T_{\text{amb}} \leq 140^{\circ}\text{F}$)
- Make sure everything is properly assembled before connecting and applying power.
- Do not open when an explosive atmosphere is present.
- Installation to be in accordance with the latest edition of National Electrical Code.
- The cable and conduit entries (1/2"-14 NPT) devices shall be certified flame proof types, suitable for the conditions of use and correctly installed.
- Unused conduit entries must be closed with suitable blanking element.
- Seal conduit entry within 18 inches.
- The user/installer shall not remove any of the three 1/8"-27 NPT plugs that are fitted into the base of the enclosure as this will invalidate the Hazardous Locations Certifications (See manual for locations).
- When using natural gas as pilot media, ERNG-X complete product must be used. The ER5050XX-1-002 by itself is not approved for natural gas.
- Excessive moisture may cause internal corrosion to ERNG-X and filter maintenance must be maintained to meet media quality requirements.
- Exhaust, pressure relief and filter drains must be vented away per local code.
- ERNG-X controller exhaust cannot be plumbed to pressure relief vent line or filter drain lines.

⚠ CAUTION

Proper Component Selection

1. Consider the total system design when selecting a component for use in a system.
2. The user is responsible for assuring all safety and warning requirements of the application are met through his/her own analysis and testing.
3. Component function, adequate ratings, proper installation, operation and maintenance are the responsibilities of the system user.

Section 3: Product Description

The ERNG-X is an accurate and reliable way of controlling natural gas. The product includes a pressure regulator, preconditioning filters and an electro pneumatic controller for automated control. The product is panel mounted and can be easily installed in an enclosure or on a wall.

The ERNG-X is a unique and flexible electropneumatic, closed loop, PID controller. The included ERTune software program provides an easy means of setup, tuning and data acquisition.

3.1 Features

3.1.1 Accurate Pressure Control

- Eliminates droop within the flowing capacity of the pipeline regulator
- Pipeline outlet pressure control is independent of the pipeline inlet pressure

3.1.2 Automation

- Remote set point control from a PC or PLC

3.1.3 ERTune™ Program

- Included with every ERNG-X, provides data acquisition routine

3.1.4 Items Included

All ERNG-X include:

- ER5050FX-1-002 with ERTune program and ER5000 User Manual (DOPMS2080X012)
- ER Supply Regulator with relief valve and gauges
- Two preconditioning coalescing filters

3.2 Controlling System Pressure

In a typical application, the control port of the ERNG-X connects to the spring case of the pipeline pilot regulator. This is shown in Figure 2. Supply pressure of up to 110 psig / 7.5 bar, is provided to the ERNG-X controller by the factory preset supply regulator.

The ERNG-X increases pressure to the spring case of the pipeline pilot regulator by opening the Pulse Width Modulation (PWM) solenoid valve at the inlet port of the ER5050FX-1-002 and reduces pressure by opening the PWM solenoid valve at the exhaust port of the ER5050FX-1-002. The controller, configured in external feedback mode, senses system pressure through input from a transducer mounted downstream in the process line. The controller reads the feedback and compares it to the setpoint, which it receives from an external source or from a profile in its onboard memory. The ERNG-X is factory set to update every 500 milliseconds and can be adjusted between 25 milliseconds and 2,500 milliseconds to better suit the application.

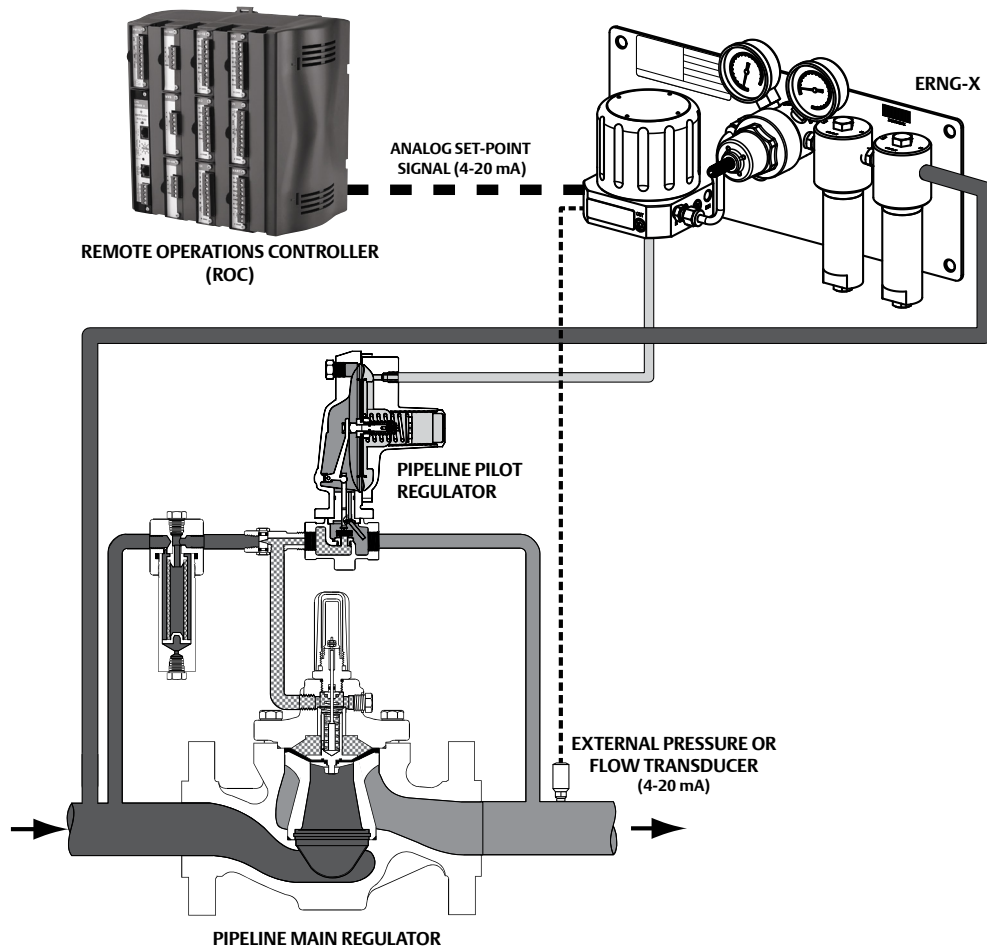

Figure 2. Typical Installation

3.3 Specifications

Electrical

Power Requirement : 20.5 - 28.5 VDC;
340 mA Max., 180 mA Nominal

Supply

Media: Natural Gas with a maximum upper explosion limit below 18% by volume at atmospheric conditions

Media Quality

Corrosives: H₂S and other sulfides below 10 PPM

Impurities: CO₂ below 3%; O₂ below 0.5%

Temperature

-4 to 140°F / -20 to 60°C (dry media required below 32°F)

Pressure

ERNG-X Panel Supply Input:

2750 psig maximum

ER5050FX-1-002 Controller Input:

maximum 110 psig, minimum output pressure +1 psig

Input Signals

Setpoint

USB, RS485, Downloaded Profile

4-20 mA, 1-5 VDC (ERNG-I)

0-10 VDC (ERNG-V)

Feedback (external)

4-20 mA or 1-5 VDC (ERNG-I)

0-10 VDC (ERNG-V)

Communication Protocol

USB and RS485 (USB not recommended for hazardous locations)

Section 4: Installation

4.1 Installation Diagram

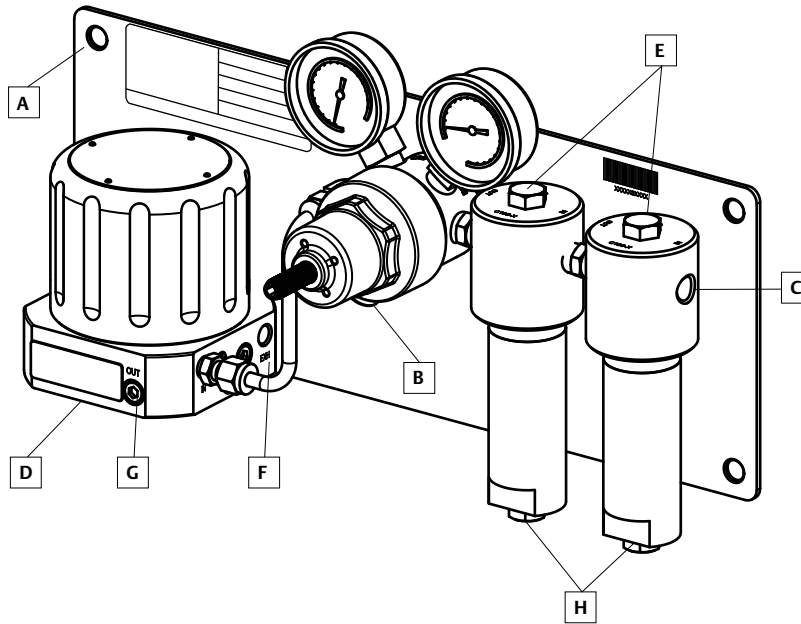

Figure 3. Wall Mount Panel

4.2 Mounting

1. Mount panel using the 4 mounting holes (A). Note: Use 3/8" or 9 mm bolts.

4.3 Connect Pressure Lines

1. Make sure the pressure of the supply line is off and attach the line to the filter inlet port (C). Note: Max pressure 2750 psig / 190 bar natural gas.
2. Connect pipeline pilot regulator spring case port to ER5050FX-1-002 control port (D). Note: An additional Out Port (G) can be used to monitor the control port pressure.
3. Attach a vent line to exhaust port (F). Note: The vent line must be installed per federal, state and local codes. The exhaust vent line must be at atmospheric pressure.
4. Attach a vent line to relief valve (B). Note: The vent line must be installed per federal, state and local codes and must be plumbed separately from exhaust port (F).
5. An optional pressure gauge can be attached above either filter port (E) to measure inlet pressure and/or pressure differential across filter elements. Note: The element must be replaced when the differential pressure reaches 10 psid, 12 psid maximum.
6. It is recommended to install valves into the drain port of the filters (H) to facilitate draining liquids from the coalescing filters as needed.

4.4 Wiring

1. Refer to ER5000 User Manual for wiring information.

4.5 Communication

The ER5000 communicates using a USB or RS485 interface. The required USB driver is provided on the ER5000 User Support Software and Manual CD or online. An RS485 communications link can be established between the ER5000 and a PC using either a USB to RS485 or RS232 to RS485 converter. RS485 communication must be used for daisy-chaining two or more (up to 32) ER5000s on the same network. RS485 is recommended for ERNG-X communication. USB is not recommended for hazardous locations and is also not recommended for distances greater than 10 ft.

4.6 System Leak Check

After installation of all components and wiring:

- Switch on the ER5050FX-1-002's power supply.
- Set the controller output pressure to a safe value. Slowly apply ER5050FX-1-002 supply pressure.

Note: ER Supply Regulator is preset from the factory to 110 psig / 7.5 bar and may be adjusted to better suit application. The ER5050FX-1-002 inlet port should not exceed 110 psig / 7.5 bar.

- Check all fittings for tightness using leak test fluid. No bubbles should be seen.

Note: Due to the increased volume of the spring case on the pipeline pilot regulator, the ER5050FX-1-002 automatic solenoid leak test should not be used.

4.7 ERNG-X Tuning

- When tuning, use conditions similar to the final application (i.e. similar pressures, flow and medium). A tuning procedure is provided in the ER5000 User Manual. There is also "Help" available in the ERTune™ program itself, available on the "Diagnostic Tools" tab in the ERTune program by clicking the "Tuning Tips" button.
- The ERNG-X is factory set to tuning parameters for the application shown in Figure 2. The update rate is slowed down from 25 milliseconds to 500 milliseconds to allow for better stability in the system and to allow for the response of the ER controller to be translated downstream to the external pressure or flow transducer before making another set-point change. There are also control limits placed on the Analog Set Point and External Sensor in case of lost communication and/or power. Both the Analog Set Point and External Sensor are preset to a minimum of -1% with a condition of Inlet Closed and Exhaust Closed. If the application does not use a 4-20 mA Analog Set Point and/or a 4-20 mA External Sense Transducer, these control limits must be changed. To better suit all applications, the tuning parameters and control features may need to be modified. Refer to ER5000 User Manual for more details.

4.8 Special Control Features Available

- Suspend Mode
- Control Limits
- Diaphragm Protection
- Pulse Mode

Note: Refer to ER5000 User Manual for more details.

Section 5: Maintenance

⚠ WARNING

The maintenance and repair of pressure equipment must only be performed by trained personnel.

If a regulator or valve leaks or malfunctions, take it out of service immediately. You must have instructions before doing any maintenance. Do not make any repairs you do not understand. Have qualified personnel make repairs. Return any equipment in need of service to your equipment supplier for evaluation and prompt service. Equipment is restored to the original factory performance specifications, if repairable. There are flat fee repair charges for each standard model. The original equipment warranty applies after a complete overhaul.

Since every application exists under different conditions, the user is responsible for establishing a maintenance program based on their application until enough data is collected to set up a schedule. Since the preconditioning filters can collect liquids, they should be checked frequently to ensure proper performance.

1. Visual check for damages (i.e. tubing, electrical components and cables).
2. Check filters for liquids and particle build up (i.e. differential pressure).
3. Check for leaks.

A periodic calibration of the feedback pressure transducer is recommended.

5.1 Filter Maintenance

Filter parts are subject to normal wear and must be inspected periodically and replaced as necessary. The frequency of inspection and replacement depends upon the severity of service conditions and upon applicable codes and government regulations.

To ensure a tight seal, check the condition of the O-ring and lubricate it with Multi-Purpose Polytetrafluoroethylene (PTFE) lubricant whenever disassembling and assembling the filter.

The upper seat is lightly pressed into the filter head. To replace the upper seat, it may be necessary to remove the 1/4 inch / 6.35 mm pipe plug and push the upper seat out of the filter head. (Refer to Figure 5 for a cross-sectional view of filter.)

To Replace C195-X Filter cartridge

1. Close the upstream and downstream shut-off valves.
2. Bleed off the pressure.
3. Open the drain valve and drain the moisture from the filter body.
4. Unscrew the filter body from the filter head. Inspect the O-ring and replace if damaged.
5. Remove the filter element.
6. Lubricate the O-ring with Multi-Purpose PTFE lubricant and reassemble the new filter element.
7. Slowly reapply pressure and check for leaks.

Section 6: Drawings

6.1 ERNG-X Dimensions

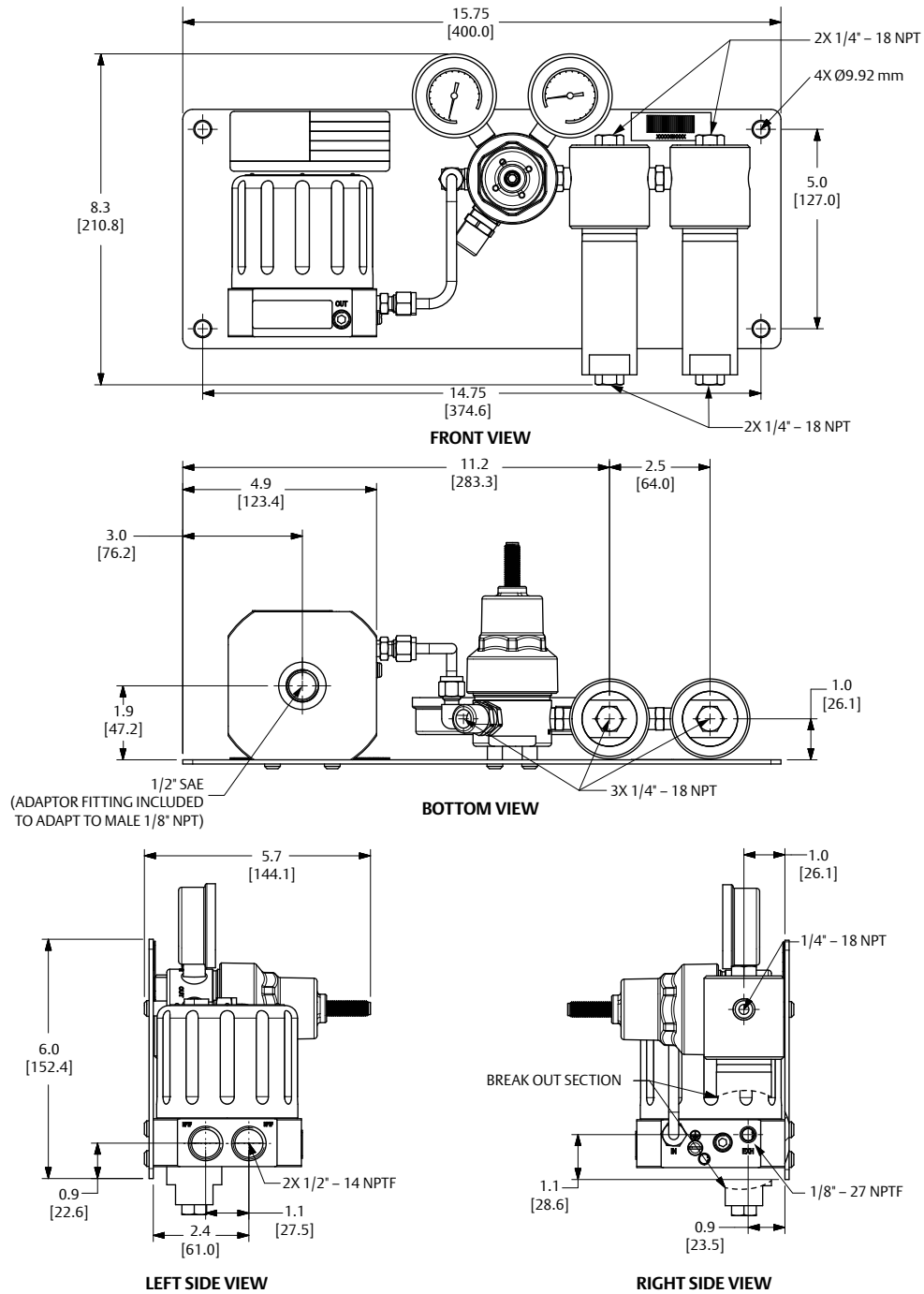

All dimensions are reference & nominal
Metric [millimeter] equivalents are in brackets

Figure 4. ERNG-X Dimensions

6.2 C195-X Filter Assembly

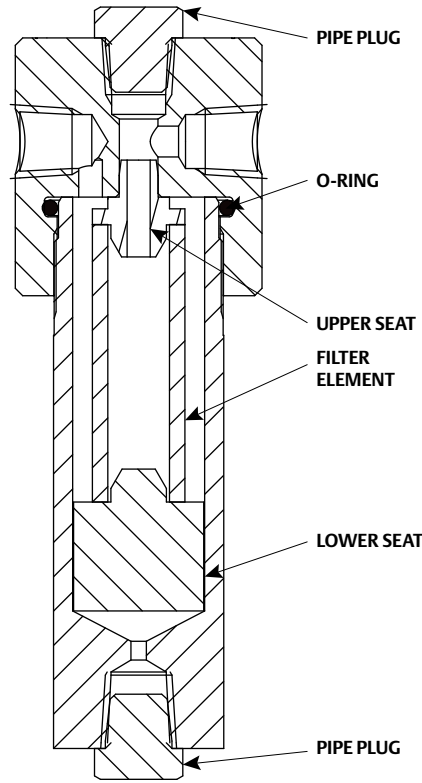

Figure 5. C195-X Filter Assembly

✉ Webadmin.Regulators@emerson.com

🔍 Tescom.com

📘 Facebook.com/EmersonAutomationSolutions

🌐 LinkedIn.com/company/emerson-automation-solutions

🐦 Twitter.com/emr_automation

Emerson Automation Solutions Regulator Technologies

Americas
Elk River, Minnesota 55330 USA
T +1 800 447 1250
+1 763 241 3238

Europe
Selmsdorf 23923, Germany
T +49 38823 31 0

Asia Pacific
Singapore 128461, Singapore
T +65 6770 8337

Middle East and Africa
Dubai, United Arab Emirates
T +971 4 811 8100

DOPSM2107X012 © 2017 Emerson Process Management Regulator Technologies, Inc. All rights reserved. 01/17.
The Emerson logo is a trademark and service mark of Emerson Electric Co. All other marks are the property of their prospective owners. TESCOM™ is a mark owned by Tescom Corporation, a business of Emerson Automation Solutions.

The contents of this publication are presented for information purposes only, and while effort has been made to ensure their accuracy, they are not to be construed as warranties or guarantees, express or implied, regarding the products or services described herein or their use or applicability. All sales are governed by our terms and conditions, which are available on request. We reserve the right to modify or improve the designs or specifications of our products at any time without notice.