

Types 472, 473, 3572, 3573

Contents

Introduction	2
Scope of Manual	2
Type Number Description	2
Actuator Specifications	2
Principle of Operation	3
Relay Operation	3
Installation	4
Positioner Connections	5
Push-Down-To-Close Valve Plug	6
Push-Down-To-Open Valve Plug	6
Adjustments	7
Reversing Series 3570 Positioner	8
Split Range Operation	9
Maintenance	9
Actuator Maintenance	10
Positioner Maintenance	10
Parts Ordering	11
Parts List	11
Types 472 and 473	11
Types 3572 and 3573	14

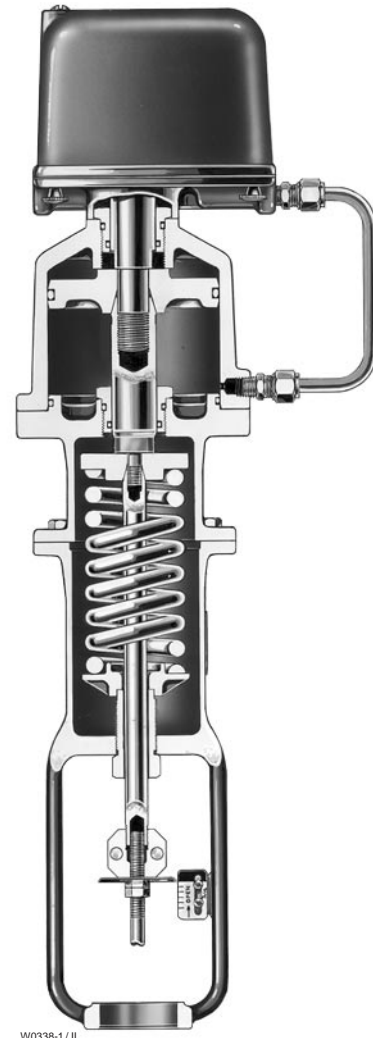

W0338-1 / IL

TYPE 472

Figure 1. Type 472



Types 472, 473, 3572, 3573

Introduction

formation about other accessories used with these actuators and positioners.

Scope of Manual

This instruction manual provides information on installation, adjustment, maintenance, and parts ordering for the Type 472 and 473 actuators in sizes 60 through 100 and the Type 3572 and 3573 positioners (see figure 1). Refer to separate instruction manuals for in-

Only personnel qualified through training or experience should install, operate, and maintain the Type 472 and 473 actuators and Type 3572 and 3573 positioners. If you have any questions about these instructions, contact your Fisher Controls sales office or sales representative before proceeding.

Type Number Description

Type Number	Description	Available Sizes
472	Air Cylinder Valve Actuator with Type 3570 Positioner ⁽³⁾ . Actuator is mounted on a Type 657 yoke and utilizes standard springs to cause an upward thrust upon loss of supply pressure. ⁽¹⁾	60, 76, 78, 80, 100
473	Air Cylinder Valve Actuator with Type 3570 Positioner. Actuator is mounted on a Type 667 yoke and utilizes standard springs to cause a downward thrust upon loss of supply pressure. ⁽²⁾	60, 76, 78, 80, 100
3572	Variation of the standard Type 3570 in which one relay is omitted. Used with the Type 472 when valve plug action is Push-Down-To-Open to avoid overloading of valve stem and valve plug. Horizontal relay loads top of cylinder to open valve, and spring action closes the valve.	One Size Only
3573	Variation of the standard Type 3570 in which one relay is omitted. Used with the Type 473 when valve plug action is Push-Down-To-Close to avoid overloading of valve stem and valve plug. Vertical relay loads bottom of cylinder to open valve and spring action closes the valve.	One Size Only

1. Type 3572 Positioner is the standard positioner for a Type 472 when valve plug action is Push-Down-To-Open. Type 3570 Positioner supplied when valve action is Push-Down-To-Close.
 2. Type 3573 Positioner is the standard positioner for a Type 473 when the valve plug action is Push-Down-To-Close.
 3. For instructions on Type 3570, see Form 1837. Instruction on the Types 3572 and 3573 are contained in this publication.

Actuator Specifications

Actuator Size	Cylinder Diameter, Inches	Effective Area, Square Inches	Yoke Boss Size, Inches	Stem Size, Inches	Allowable Stem Force, Pounds	Travel, Inches	Maximum Supply Pressure, psi
60	8-1/2	55.5	3-9/16	3/4	5000	7/16 to 2	100
80	10-3/4	88.5	5	1	8000	3/4 to 3	100
100	13	130.5	5	1-1/4	12000	3/4 to 3	100

The Types 472 and 473 are spring return actuators used to provide "fail safe" action upon loss of supply pressure. See table below.

Inner Valve Action	Type 472	Type 473	Positioner Used
Push-Down-To-Close	Fail Open		Type 3570
Push-Down-To-Open	Fail Closed		Type 3572 ⁽¹⁾
Push-Down-To-Close		Fail Closed	Type 3573 ⁽¹⁾
Push-Down-To-Open		Fail Open	Type 3570

1. One relay positioner.

Types 472, 473, 3572, 3573

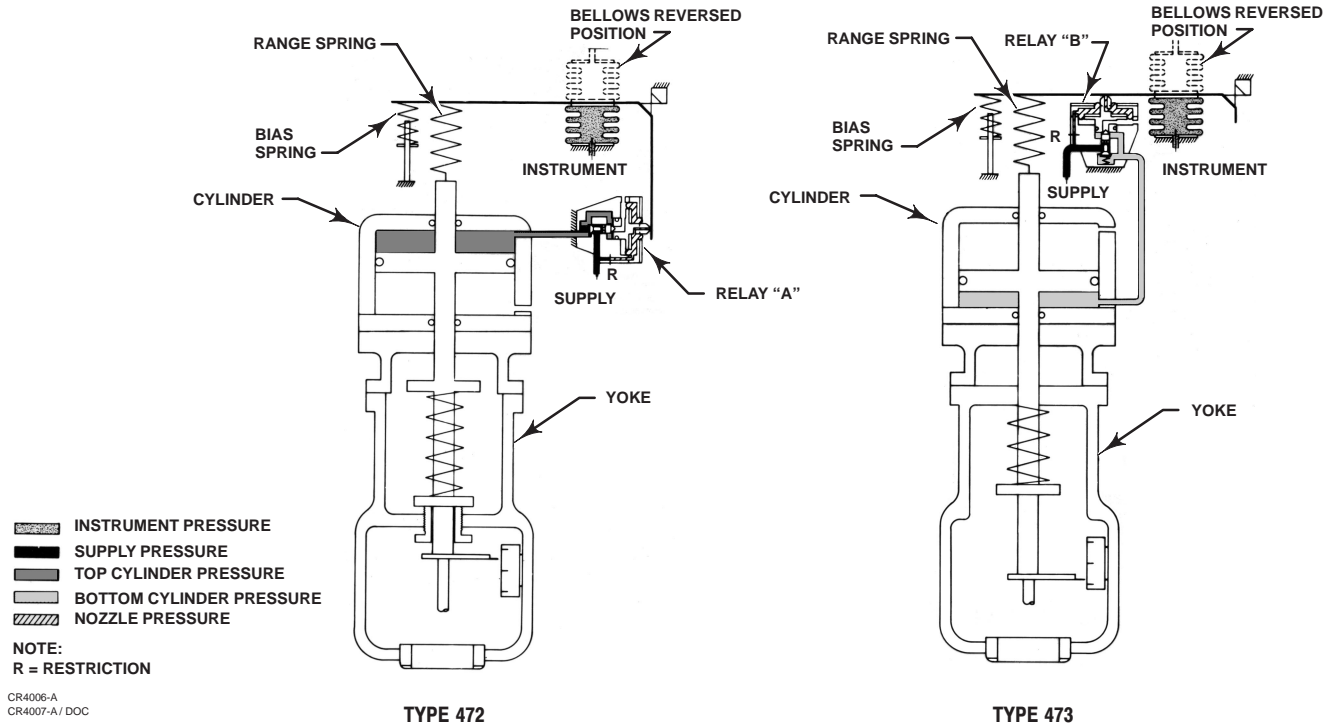

Figure 2. Schematics (Types 472 and 473)

Principle of Operation

Refer to figure 2. The pneumatic pressure signal from a controller or instrument is piped to the bellows of the Series 3570 positioner. For explanation purposes, assume this instrument signal has increased. The bellows expands and moves the beam, which pivots around a fixed point, and simultaneously uncovers the nozzle of relay "B" and covers the nozzle of relay "A". The nozzle pressure in relay "A" increases due to the restriction created by the beam over the nozzle. Through relay action, the air pressure to the top of the piston increases. At the same time, relay "B" reacts to the change in beam position to decrease the pressure to the underside of the piston. Due to the unbalanced pressures acting on the piston, it moves down, returning the valve plug position to the desired control point.

Piston movement is fed back to the beam by means of a range spring which is connected to the beam and to an extension of the piston rod. This feedback arrangement prevents over-correction and ensures a definite position of the piston and valve plug for a given instrument signal, thus giving stable and accurate response to a change in controlled conditions.

Upon receipt of a decreasing instrument signal, the reverse action takes place. The bellow contracts and, as the beam pivots, it restricts the nozzle of relay "B" and uncovers the nozzle of relay "A". Through relay

action, the pressure below the piston increases and the pressure above the piston decreases to move the piston upward.

If the Type 3572 positioner is being used, Relay "B" is omitted, and on the 3573 positioner, Relay "A" is omitted. In both instances, a spring is used to oppose loading pressure supplied through the relay, and to provide closing action for the valve plug should operating medium fail.

Relay Operation

Refer to figures 2 and 3. Supply pressure reaches the relay through passages in the positioner base, and is channeled to fixed restriction "R", and to a point "A", between the inlet valve and its balancing O-ring. The fixed restriction is an integral part of the relay restriction plug and wire assembly "G". The orifice in nozzle "F" is larger than the fixed restriction. This allows air to bleed to atmosphere faster than it enters the unit through the fixed restriction when the beam flapper is away from the nozzle.

To explain the relay operation, assume that a change in controlled conditions causes the beam flapper to cover the nozzle of the relay. Air flows through fixed restriction "R" into the chamber between the two relay diaphragms. Due to the restricting effect of the flapper over the nozzle, pressure builds up in the chamber

Types 472, 473, 3572, 3573

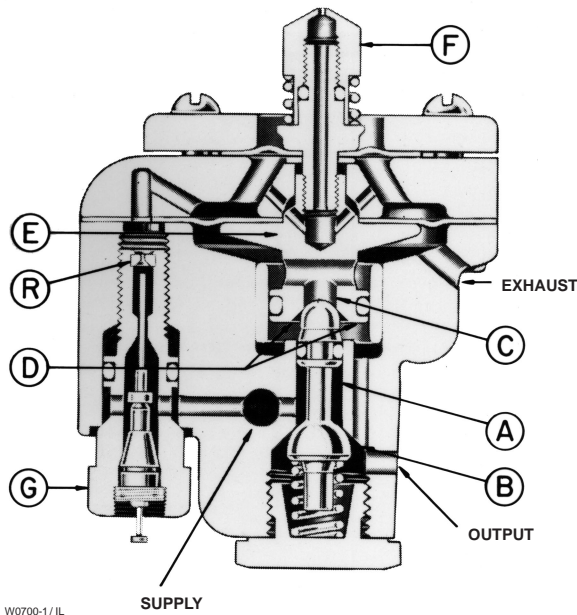

Figure 3. Sectional View of Positioner Relay

between diaphragms, forcing diaphragm head assembly “E” downward to open inlet valve “B”. Supply pressure flows past the inlet valve to increase the output pressure to the cylinder. The cylinder pressure (relay output pressure) also acts on area “D” to provide an air feedback and return diaphragm head assembly “E” and movable nozzle “F” to its original position, thus preventing any further increase in output pressure. This feedback arrangement and the movable nozzle ensure accurate and stable positioning of the actuator piston without introducing cycling or over-correction. After any change in the relay output pressure, inlet valve “B” and exhaust valve “C” always return to the closed position to put the nozzle back in its original or equilibrium position. The spring behind the inlet valve aids in closing the valve as the diaphragm head assembly is forced upward.

When the beam flapper moves away from the nozzle, air bleeds out at a greater rate than it enters through the fixed restriction. The pressure in the chamber between diaphragms decreases. The force of the cylinder pressure acting on area “D” pushes diaphragm head assembly “E” upward, opening exhaust port “C”. Cylinder pressure bleeds through the exhaust port to atmosphere. As the cylinder pressure decreases and force on area “D” decreases, the force of the nozzle pressure in the chamber between diaphragms returns the assembly to its original position. The unit is again in equilibrium but at a lower nozzle pressure and a lower output pressure.

The relay has a 4:1 ratio between nozzle and output pressure. For example, if the nozzle pressure is 10 psi, the output pressure is 40 psi. Regardless of the

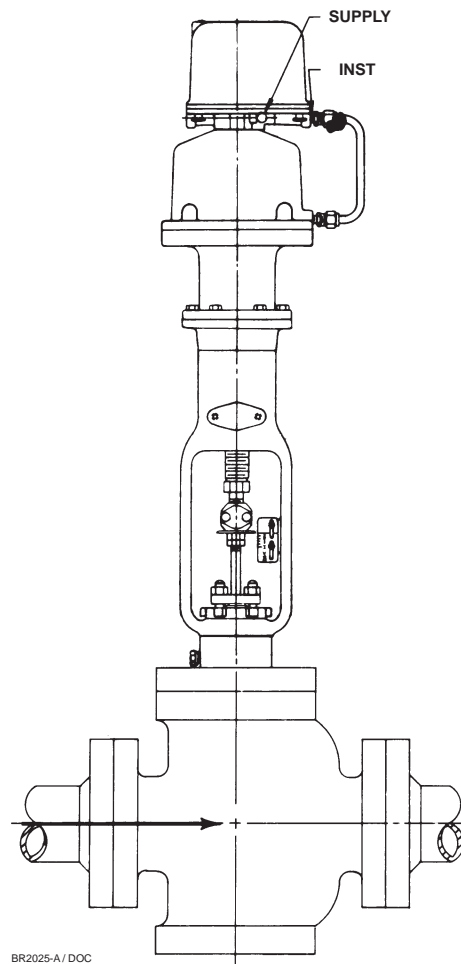

Figure 4. Type 472 or 473 Installation

pressure, however, the internal parts of the relay are always in equilibrium, with the exhaust and the inlet valves closed, before a change in the output pressure is called for by a change in controlled conditions.

Installation



The Type 472 and 473 piston actuators should not be used with the Type 3570 (two-relay) positioner. If supply pressure is lost, the full-travel, fail-mode position might not be reached. Use only a Type 3572 positioner with the Type 472 actuator. Use only a Type 3573 positioner with the Type 473 actuator.

Note

Review your requirements for the Type 472 and 3572 combination and the Type

Types 472, 473, 3572, 3573

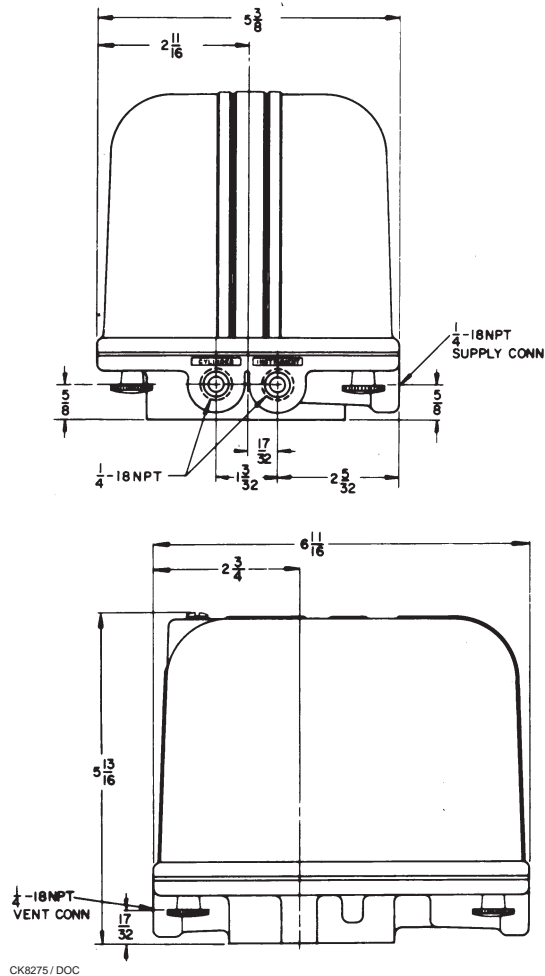

Figure 5. Positioner Connections

473 and 3573 combination. If the actuator and positioner are to move the valve or other device to a fail-mode position, be sure the top (or bottom) cylinder that is connected to the positioner relay is equipped with a device (such as a solenoid) to vent the top (or bottom) of the cylinder on loss of supply pressure. Ensure that the cylinder not connected to the positioner relay is adequately vented.

The Type 472 or 473 will probably be mounted on a valve body. Install the control valve in the line so that flow is in the direction indicated by the arrow cast on the valve body. See figure 4.

Positioner Connections

Refer to figure 5.

There are four 1/4-inch NPT tapped holes in the positioner base. These connection points are labeled: Cylinder, Vent, Supply and Instrument.

1. **Cylinder**—The Cylinder connection from the positioner to the lower part of the cylinder is made at the factory.
2. **Vent**—The Vent connection should be left open to prevent a pressure buildup in the case, and also to provide a drain for any moisture that might collect inside the case. In connection with the case venting, there is a slotted cadmium-plated pipe plug screwed into the top of the positioner cover. In other than normal vertical control valve mounting, this pipe plug should be removed and screwed into the vent hole. This provides a drain and vent at the lowest point of the positioner assembly.
3. **Supply**—The supply pressure to the positioner must be clean, dry, non-corrosive air or gas. It is recommended that a filter such as a Fisher Controls Type 254 be installed in the supply line. The maximum allowable supply pressure is stamped on the nameplate attached to the actuator yoke. The minimum supply pressure for all sizes is 30 psi. However, to utilize the full power potential of a Series 470 actuator, the supply pressure should be as close to the maximum pressure as possible. To make the supply line connection, run 3/8-inch tubing or 1/4-inch pipe from the supply source through the filter to the Supply connection on the positioner.
4. **Instrument**—Types 472 or 473 control valves are employed in conjunction with an instrument or controller. The instrument may be pneumatic, electric or electronic and may be controlling pressure, liquid level, temperature, flow, etc. Regardless of the controlled variable or style of controller, the instrument pressure to the Series 3570 positioner must be pneumatic. Consequently, electric or electronic instruments require a transducer, such as a Fisher Controls Type 546, to convert a milliampere signal into a pneumatic one. The Series 3570 positioner can be supplied to operate on almost any pneumatic instrument pressure range. The range for which the positioner has been adjusted is indicated on the positioner nameplate. To make the instrument pressure connection, run tubing or piping to the Instrument connection from the controlling device.

In some instances, a Type 472 or 473 will be ordered with the controller yoke mounted to the unit. In this case, the instrument connection is made at the factory. However, the controller will require a supply pressure connection to the case and a control pressure connection to the main pipeline. Refer to the controller instruction manual for directions in making these connections.

Types 472, 473, 3572, 3573

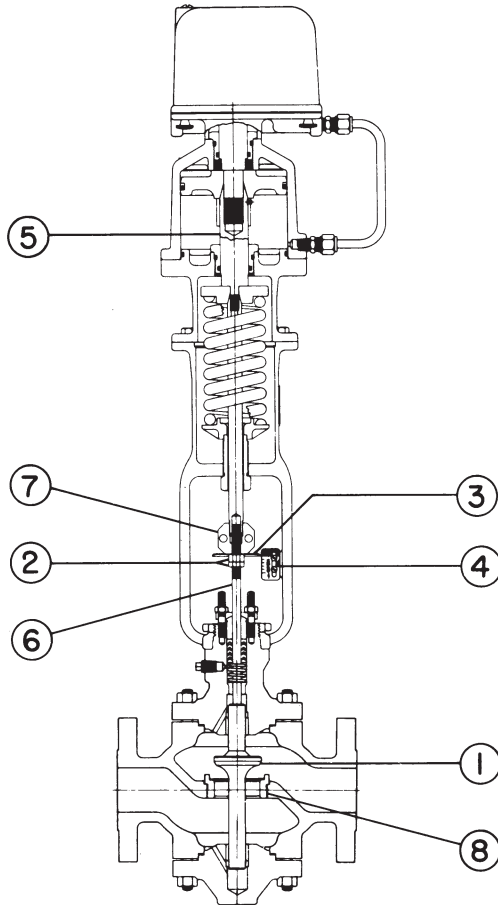

CJ2283-B / DOC

Figure 6. Type 472 Assembly

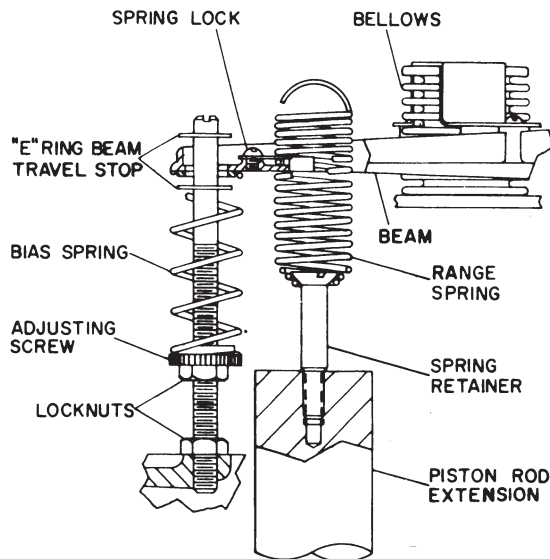

AJ7270-C / DOC

Figure 7. Bias and Range Spring Arrangement

If a Type 472 or 473 actuator is purchased separately, to be mounted on a valve body, follow the procedure outlined below. See figure 6.

Push-Down-To-Close Valve Plug

1. Place the actuator onto the valve body, and secure with the yoke lock nut. (If the actuator has a five-inch yoke boss, stud bolts replace the yoke lock nut.) Then move the valve plug (key 1) to the closed position.
2. Screw the locknuts (key 2) onto the stem and set the travel indicator disk (key 3) on these nuts with the cupped portion downward. Leave enough threads exposed on the stem above the indicator disk for the stem connector. Set the indicator disk to read closed on the indicator plate (key 4).
3. If the actuator rod (key 5) is not in the up position, pressure the actuator to move the rod to the top of its stroke.
4. Pull the stem (key 6) up until the travel indicator disk shows that full travel has been obtained.
5. Attach the stem connector, (key 7) clamping the actuator rod to the stem.
6. Apply pressure to the actuator to see that full travel is obtained and that the valve plug seats on the seat rings (key 8). If it does not, use a wrench on the stem locknuts, and turn the stem into or out of the connector until correct travel is reached.



CAUTION

To avoid damaging the seating surface, the valve stem should not be turned when the valve plug is seated.

Tighten the stem locknuts to clamp the indicator disk between the connector and locknuts. Set indicator plate to show valve plug position.

7. Provide a pressure gauge to measure the pressure to the actuator. Make a final adjustment on the actuator or its positioner to set the starting point of valve travel and to obtain full valve travel for the given instrument range.

Push-Down-To-Open Valve Plug

1. Place the actuator onto the valve body, and secure with yoke lock nut. (If the actuator has a five-inch yoke boss, stud bolts replace the yoke lock nut.) Then move the valve plug (key 1) to the closed position.
2. Screw the locknuts (key 2) onto the stem and set the travel indicator disk (key 3) on these nuts with the cupped portion downward. Leave enough threads exposed above the disk for the stem connector.

3. If the actuator rod (key 5) is not in the up position, pressure the actuator to move the rod to the top of its stroke.
4. Reduce the pressure to the actuator to move the rod down 1/8-inch. On actuators where the rod is normally at the top of the stroke, apply pressure to move the rod 1/8-inch. Make up the stem connector (key 7) clamping the actuator rod to the stem (key 6).
5. Apply pressure to the actuator to see that full travel is obtained and that the valve plug seats on the seat ring(s) (key 8). If it does not, use a wrench on the stem locknuts and turn the stem into or out of the connector until correct travel is reached.
6. Lock the travel indicator disk against the connector with the locknuts. Set indicator plate (key 4) to show valve plug position.
7. Provide a pressure gauge to measure the pressure to the actuator. Make a final adjustment on the actuator or positioner to set the starting point of valve travel and to obtain full travel for the given instrument range.

Adjustments

The three main adjustments on a Type 472 or 473 control valve are located in the positioner. These adjustments include a bias spring setting which is used to obtain the correct starting point of valve travel, a range spring setting which is used to obtain full travel for a given instrument range, and a relay nozzle adjustment which is basically a sensitivity adjustment. Figure 7 shows the arrangement of the bias spring and range spring.

In some cases, on Sizes 80 and 100, the main spring can be adjusted to handle higher pressure drops than are stated on the order.

No adjustments are necessary upon installation as the positioner has been set at the factory for the travel, instrument range, action, etc., specified in the order. It is only when operating conditions are changed or the unit has been dismantled and reassembled that these adjustments need to be made.

One important point is that when changing operating conditions it is necessary to check with the factory to see if a new range spring and retainer, and a new bias spring are required. The factory will check the revised operating conditions and supply the new parts, if required.

To illustrate the use of the various adjustments, assume that the actuator has been repaired or has become completely out of adjustment. Assume also that

the instrument pressure range is 3 to 15 psi. Proceed as follows:

1. Make sure the instrument signal range and valve travel stamped on the Series 3570 nameplate agree with operating conditions. Valve and actuator travel must agree.
2. Bypass the main valve or shut down the pressure, if possible, to remove unbalance forces which make adjustment more difficult.
3. A means should be provided for varying the instrument pressure from zero to 1 or 2 psi above the maximum signal. Provide an accurate means of measuring the instrument pressure. Check the positioner instrument pressure gauge for accuracy.
4. Open supply and instrument pressure lines. Set the instrument pressure at the mid-point of its range, 9 psi in this example. Observe the valve travel indicator attached to the yoke. Valve should be somewhere between the open and closed positions.
5. Loosen the locknut below the bias spring adjusting screw (see figure 7) and adjust the bias spring up or down until the valve travel indicator disk shows that the valve plug is at mid-travel. If the positioner is direct acting (check action label), upward movement of the bias spring adjusting screw causes downward travel of the valve stem. If the positioner is reverse acting, upward movement of the adjusting screw causes upward movement of the valve stem.
6. The beam should be in a horizontal position and the free end of the beam at the bias spring end should be located mid-way between the two "E" ring travel stops on the bias spring post. Therefore, the relay nozzle should be moved in or out so that the beam is balanced centrally between the travel stops and also that the cylinder pressure is proper for the spring force involved. This will be affected by the effective area of the piston, and the compression rate of the spring used.

If the 3570 positioner is being adjusted, the nozzle pressure should be set at 75% of supply pressure. This operation can be facilitated by inserting a block 1/8-inch thick between the upper "E" ring travel stop and the beam while making the adjustment.
7. The next step is to vary the instrument pressure from zero to a few psi above the maximum value, 15 psi in this example. Observe the travel of the valve plug on the travel indicator plate and determine the instrument pressures for the starting and ending points of valve travel. If more pressure change than the given range (12 psi) is required to obtain the designated travel, the range spring (see figure 7) must be adjusted in a counterclockwise direction. This decreases the necessary instrument pressure change to provide full valve travel. If the pressure change range is less than the required range (12 psi in this example) the range spring should be adjusted clockwise.

Types 472, 473, 3572, 3573

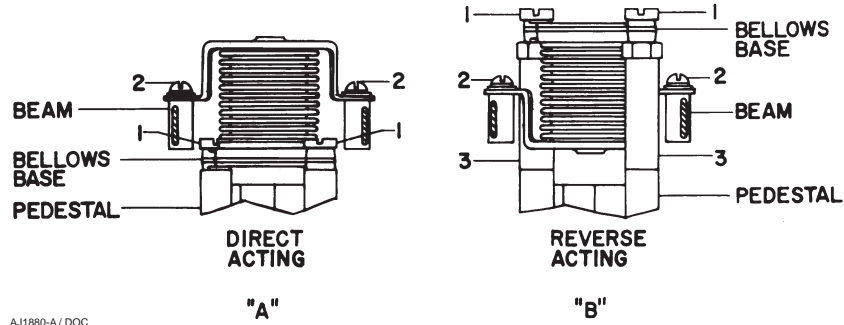

Figure 8. Bellows Mounting for Direct and Reverse Acting

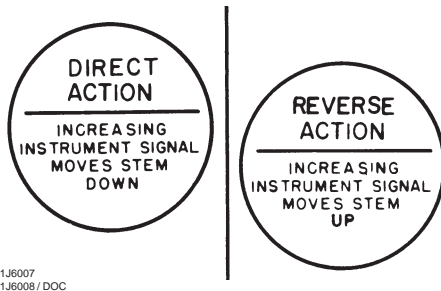

Figure 9. Positioner Action Labels

8. With the relay nozzle set and the range spring adjusted properly, make a final adjustment of the bias spring so that the start of valve travel is at the instrument pressure starting point (3 psi in this example with a 3 to 15 psi range).

9. Lock the range and bias spring in position and commence operation.

Reversing Series 3570 Positioner

Series 3570 positioners are assembled to provide either direct or reverse action. Direct action is when the piston and valve stem move down as an increasing instrument signal is received by the bellows in the 3570 positioner. Conversely, reverse action causes the piston and valve stem to move up as the positioner receives an increasing instrument signal. Figure 9 show two labels, one of which is used to indicate the action of the positioner. The direct or reverse action label is on the outside of the positioner cover.

To change to positioner from direct acting to reverse acting, proceed as follows:

1. Bypass the control valve and shut off the instrument and supply pressure lines to the positioner.

2. Remove the positioner cover by loosening the four knurled thumb screws on the underside of the base.

3. Two bellows posts are provided, screwed into the positioner base immediately above the Cylinder and Instrument connections. Unscrew these posts.

4. Referring to figure 8, remove screws number 1 and number 2 and lift out the bellows assembly.

5. Screw the bellows posts, number 3, into the holes where screws number 1 originally were.

6. Invert the bellows and replace screws number 1 and number 2.

7. Open supply and instrument pressure lines and adjust the bias spring by turning the adjusting screw clockwise to obtain the correct starting point of piston travel. See the *Adjustments* section. If the instrument range has not been changed, no range spring adjustment is necessary.

8. Make a notation on the action label that the action of the positioner has been changed.

9. Replace cover and resume operation.

When changing the action from reverse to direct follow this procedure:

1. Bypass control valve and secure instrument and supply pressure. Remove positioner cover.

2. Remove four screws, numbers 1 and 2, figure 8, bellows and bellows posts number 3.

3. Turn bellows over and replace screws, omitting the bellows posts. Screw posts into base hole for future need.

4. Open instrument and supply pressure lines and adjust bias spring to obtain correct starting point of piston travel.

5. Note on action label that the action has been changed.

6. Replace cover and resume operation.

Split Range Operation

Series 3570 positioners are suitable for split range operation, that is where two control valves are operated by the instrument pressure signal from a single controller. One valve strokes fully with one half the instrument pressure range and the second valve strokes completely with the other half of the instrument pressure range.

To convert an existing control valve to one suitable for split range operation, the factory must be consulted to determine new parts required. For any change, a new range spring and range spring retainer will be required and possibly, a new bias spring. When communicating with the factory, supply all information possible about the desired operating conditions and the serial numbers of the control valve assembly to facilitate the proper selection of the required parts.

To change a Series 3570 positioner to one suitable for split range operation, proceed as follows: Assume required new parts are on hand.

1. Bypass control valve and shut off instrument pressure and supply pressure lines to the positioner.
2. Loosen the spring clip holding the range spring in position. Using a screwdriver, remove the spring retainer from the piston rod extension. Remove the range spring by turning it counterclockwise.
3. Install the new range spring and spring retainer. Screw the retainer into the piston rod extension.
4. Remove the bias spring and the bias spring post by first removing the "E" ring travel stop on the post above the beam. Then slack off the nut that holds the bias spring post and pressure gauge bracket to the positioner base. Adjust the bias spring as low as possible on the post. Using a screwdriver, unscrew the post from the base. When the post is free of the base, tilt the bottom end out and remove the bias spring post.
5. Install the new bias spring. Replace the "E" ring travel stop.
6. Adjust the unit following the procedure outlined under the section *Adjustments*, and remember that now the instrument pressure range to the positioner is only a portion of the controller output pressure.

Split range control valves can be reversed as described under the section *Reversing Series 3570 Positioner*. However here again, the factory should be consulted to determine if new range and zero springs, and a new retainer are required.

Maintenance

Actuator parts are subject to normal wear and must be inspected and replaced when necessary. The frequency of inspection and replacement depends on the severity of service conditions. Because of the care Fisher Controls takes in meeting all manufacturing requirements (such as heat treating and dimensional tolerances), use only replacement parts manufactured or furnished by Fisher Controls.

WARNING

Avoid personal injury or property damage from sudden release of process pressure or bursting of parts. Before performing any maintenance operations:

- **Disconnect any operating lines providing air pressure, electric power, or a control signal to the actuator. Be sure the actuator cannot suddenly open or close the valve.**
- **Use bypass valves or completely shut off the process to isolate the valve from process pressure. Relieve process pressure from both sides of the valve. Drain the process media from both sides of the valve.**
- **Vent the power actuator loading pressure and relieve any actuator spring precompression.**
- **Use lock-out procedures to be sure that the above measures stay in effect while you work on the equipment.**

When performing maintenance procedures, isolate the control valve from the process line pressure, release pressure from both sides of the valve body, and drain the process media from both sides of the valve. Use lock-out procedures to be sure that the above measures stay in effect while you are working on the actuator.

The primary consideration in the maintenance of Types 472 or 473 actuators is cleanliness, and the second is proper lubrication. Upon assembly at the factory, all synthetic rubber O-rings have been coated with Lubriplate MAG-1 or equivalent. Use this lubricant on all O-rings, whenever the actuator is dismantled for maintenance.

The following procedure should be used in disassembly of a Type 472 or 473 actuator:

Types 472, 473, 3572, 3573

Actuator Maintenance

Should it become necessary to dismantle the Type 472 or 473 for maintenance, proceed as follows. Be sure all air pressure is out of the cylinder before dismantling the actuator.



CAUTION

Always disconnect the range spring from the piston rod extension before dismantling any parts on a Type 473 to prevent damage to the range spring from elongation past its safe limits by the free expansion of the main spring.

1. Bypass the control valve and shut off all pressure lines to the positioner. Remove all tubing lines (cylinder, instrument and supply) from the positioner base.
2. Remove positioner cover after loosening the four cover screws on the underside of the positioner.
3. Disengage range spring by unscrewing the spring retainer from the piston rod extension.
4. Loosen the two cap screws that hold the positioner to the cylinder. When removing positioner, do not lose the small O-ring that is used in the air passage from the positioner to the top of the cylinder.
5. Next remove the stem connector (key 6) and the rubber boot (key 24) used to protect the lower end of the piston rod.
6. Remove the socket head cap screws that hold the cylinder (key 2) to the yoke (key 1).
7. Two slots, 180 degrees apart, are located at the lower edge of the cylinder casting. Insert a screwdriver into these slots and pry the cylinder loose from the yoke. Remove the cylinder, being careful not to mar the cylinder wall.
8. The piston (key 3) and piston rod (key 4) will come out with the cylinder. The piston can then be removed by forcing it out the open end of the cylinder.
9. Unscrew both seal bushings, one in the upper (key 7) end of the cylinder and the other screwed into the upper (key 8) end of the yoke.
10. With the unit disassembled, inspect all parts for excessive wear and defects. Replace all worn O-rings. Lubricate with Lubriplate MAG-1 or equivalent.
11. To reassemble, reverse the above procedure.

Note

When reassembling the actuator after the piston rod extension (key 5) has been removed from the piston rod (key

4), clean the threads of the piston rod thoroughly and apply Loctite 242 or equivalent thread sealant to the threads. Tighten the piston rod extension securely to a torque of 150 lbf•ft (203 N•m). This torque is approximately equal to the torque that would be developed by placing a force of 150 pounds on the end of a one-foot wrench, 75 pounds on the end of a two-foot wrench, etc.

Note

For actuator sizes 60, 76, and 78 of the Type 472, and for actuator sizes 46 and 60 of the Type 473, different adjusting screws are specified to ensure that the initial spring force and the spring force at a given travel are known. The proper initial compression or spring force is obtained with these adjusting screws by turning them in as far as they will go.

For the larger size actuator of the Type 472 and Type 473, the same adjusting screw is used for all springs. In this case, the correct initial compression or spring force is obtained by turning the adjusting screw in a specified distance.

Positioner Maintenance

The cause of improper operation of a Type 472 or 473 actuator will more than likely be found in the Series 3570 positioner. If the correct springs are installed for the current operating conditions and careful adjustment of the unit does not produce satisfactory operation, the following points should be checked.

1. Clean out the primary orifice on each relay by depressing the cleanout plunger. See figure 3. This operation runs a fine wire through the orifice to clear it.
2. Check the nozzle of the relay for plugging. To clean, swing the flapper away from the nozzle. Unscrew the nozzle and run a fine wire through it. Also check the surface of the flapper for any accumulation of dirt or foreign materials.
3. Check the bellows assembly for damage, cocking or leakage. Also check all gasketed joints for leakage. Use soap suds for leak detection.
4. Check the beam for damage, binding or rubbing against stationary parts. Check flexure strip screws for tightness.
5. If all else fails remove the relay from the unit and disassemble. Check the following points:
 - a. The two relay diaphragms for holes or cuts. Note that the larger of the two diaphragms has five

Types 472, 473, 3572, 3573

holes in it, four for the flange screws and one to permit the flow of air from the primary orifice to the chamber between diaphragms.

b. The relay inner valve for nicks, cuts, or dirt. Also check both inlet and exhaust ports.

c. All O-rings for wear or damage.

d. All metal parts for damage. Do not attempt to remove the stainless steel bushing in the relay body. If this part is damaged, a new relay body should be ordered from the factory.

e. Cleanout wire assembly for the primary orifice.

When reassembling, clean all parts and use Lubriplate MAG-1 or equivalent on all O-rings. In replacing the end flange, depress the nozzle and hold it down until the four flange screws are tightened. This ensures the proper amount of slack in the two diaphragms. Mount the relay in its proper position on the positioner pedestal, making sure that the relay gasket is good and in place. Adjust the actuator as described in these instructions under the section *Adjustments*.

Parts Ordering

Each actuator has a serial number stamped on the nameplate. Always mention this number when corresponding with your Fisher Controls sales office or sales representative regarding technical information or replacement parts. Also, reference the complete 11-digit part number of each needed part as found in the following parts list.

The positioner has its own serial number.

Parts List

Types 472 and 473

Key	Description	Part Number
1	Cylinder Adaptor, Aluminum	
	Size 60	2H894907062
	Size 76	2N870207062
	Size 78, Type 473	2P737407062
	Size 80	2H945807062
	Size 100	2H946007062
2	Cylinder Assembly	
	Size 60	3H8713000A2
	Size 76, Type 472	3K1641000A2
	Size 76, Type 473	3H9424000A2
	Size 78-Type 472, Size 80-Type 472 and 473	3K1642000A2
	Size 100	3J4980000A2

Key	Description	Part Number
3	Piston, Aluminum	
	Size 60, 76	2H865807062
	Size 80	2H873307062
	Size 100	2H873707062
4	Piston Rod, 416 SST	
	Size 60	1H897446322
	Size 76	1J418131082
	Size 78	2P737546322
	Size 80, 100	2H945746322
5	Piston Rod Extension, SST	
	Size 60. Also Size 76 & 78 for 2-in or less tvl	1H864946582
	Size 76 & 78 for over 2-in tvl & all Size 80 & 100	2H872946582
6	Stem Connector Assy	
	Size 60	1E8337000A2
	Size 76-Type 472	1H8655000A2
	Size 76 & 78-Type 473	1N1319000A2
	Size 80 & 100, 1-in stem	1K3536000A2
	Size 100	1K3526000A2
7*	Upper Seal Bushing, Brass, 2 req'd on sizes 70 & 76, 1 req'd on sizes 78, 80, & 100	1H865114042
8*	Lower Seal Bushing, Brass, Sizes 78, 80, & 100	1H946314042
9*	Stem Seal O-Ring, Syn Rubber, 2 req'd	1E736906992
10*	Bushing Seal O-Ring, Syn Rubber, 2 req'd	1D348306992
11*	Piston O-Ring, Syn Rubber	
	Size 60, 76	1H862406992
	Size 78, 80	1H862506992
	Size 100	1H862606992
12*	Cylinder O-Ring, Syn Rubber	
	Size 60, 76	1H862306992
	Size 78, 80	1H862506992
	Size 100	1H862606992
13	Cap Screw, Steel, size 60, 8 req'd	1A771132982
	Size 80, 10 req'd	1A771132982
	Size 100, 16 req'd	1A771132982
14	Compression Fitting, Brass, 2 req'd	1H868218992
15	Cylinder Tubing, Copper	
	Size 60, 76	1H865217012
	Size 78, 80	1H866017012
	Size 100	1H873417012
16	Travel Indicator Disk, SST	
	Size 76, 78 Type 472	1B971838992
	Size 60, 76 Type 473	1E832838992
	Size 80, 100	1H736438992
17	Nut, Steel, 2 req'd	
	Size 60, 76, 78	1A375424122
18	Jam Nut, Steel	
	Size 60, 76, 78	1A351124122
	Size 80, 100, 1-in stem	1C635224122
	Size 80, 100, 1-1/4 in stem	0W073524122
19	Travel Indicator Screw, SST, 2 req'd	
	Size 60, 76, 78	1E831338992
	Size 80, 100	1A343128992
20	Travel Indicator Plate, SST	
	Size 60, 7/16 travel	1F535238992
	Size 60, 5/8 travel	1E833038992
	Size 60, 3/4 travel, Type 472 & 473	
	Size 76, Type 472	1E833138992
	Size 60, 7/8 travel	1H147838992
	Size 60, 1-1/8 travel, Type 472 & 473	
	Size 76, Type 472	1E833238992
	Size 60, 1-1/2 travel, Type 472 & 473	
	Size 76, Type 472	1E833338992
	Size 60, 2 travel, Type 472 & 473	
	Size 76, Type 472	1E833438992
	Size 76, 3 travel, Type 472	1N129838992
	Size 76, 3/4 travel, Type 472	
	Size 80 & 100 Type 472 & 473	1H745738992

Types 472, 473, 3572, 3573

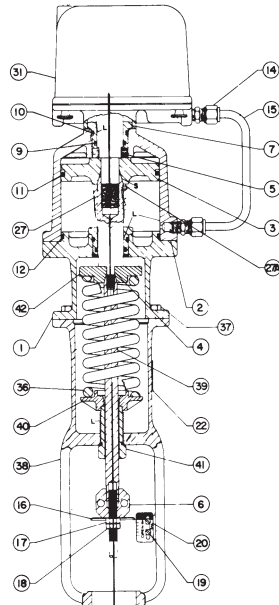

PARTS NOT SHOWN 13, 21, 23
DH9063 / DOC

Figure 10. Type 472, Size 60

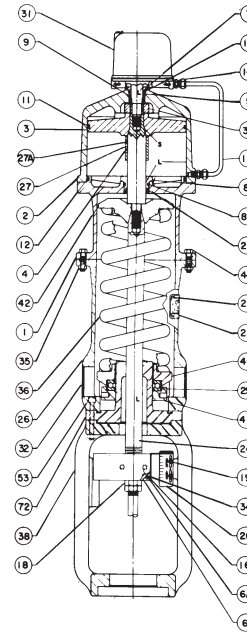

PART NOT SHOWN 13, 119, 120, 43
DK5320 / DOC

Figure 11. Type 472, Sizes 80-100

Key	Description	Part Number	Key	Description	Part Number
20	Travel Indicator Plate, SST (cont'd)		27	Travel Stop, Steel (cont'd)	
	Size 76, 1-1/8 travel, Type 472			Size 78, 80, 100, 3/4 tvl	1H950926012
	Size 80 & 100 Type 472 & 473	1H745838992		Size 78, 80, 100, 1-1/8 tvl	1H950826012
	Size 76, 1-1/2 travel, Type 472			Size 78, 80, 100, 1-1/2 tvl	1H950726012
	Size 80 & 100 Type 472 & 473	1H745938992		Size 78, 80, 100, 2 tvl	1H950626012
	Size 76, 2 travel, Type 472			Size 78, 80, 100, 3 tvl	1H950526012
	Size 80 & 100 Type 472 & 473	1H746038992	27A	Set Screw, Steel	
	Size 76, 3 travel, Type 472			Size 60, 76	1E623428992
	Size 80 & 100 Type 472 & 473	1H746138992	27A	Groove Pin, Steel	
	Size 76, 2-3/8 travel, Type 473	1K727638992		Size 78, 80, 100	1A361728992
	Size 76, 2-1/2 travel, Type 473	1K511038992	28*	Lower Stem Seal O-Ring, Syn Rubber	
21	Travel Indicator Plate Nut, SST			Size 78 Type 473 &	
	Size 60, 76, 78	1E833538992		Size 80 & 100 Types 472 & 473	1H862706992
22	Nameplate, All Sizes, SST	1H863538992	29	Thrust Bearing, Steel	
23	Nameplate Screw, Steel, 4 req'd	1A368228992		Size 80 & 100	1H733128992
24	Actuator Stem, Steel		30	Piston Nut, Size 78 Type 473 &	
	Type 472, Size 80, 100	1J544024092		Size 80 & 100 Types 472 & 473	1H872024102
	Type 473, Size 80, 100	2N559924102	32	Cover Band Assembly	
25	Rod Adaptor, Type 473, Steel			Size 80 & 100	1H7338000A2
	Size 60, 76, 78	1H895224092	33	Cap Screw, Steel, 6 req'd	
	Size 80, 100	1H945524092		Type 473	1H735132992
26	Spring Case, Size 80, 100	3J833919042	34	Screw	
27	Travel Stop, Steel			Size 80 & 100	1H736528992
	Size 60, 7/16 tvl	1H894226062	35	Nut, Steel, 18 req'd	
	Size 60, 5/8 tvl	1H894126062		Size 80 & 100	1A341224122
	Size 60, 3/4 tvl	1H894026062	36	Spring, Steel	
	Size 60, 7/8 tvl	1H893926062		Size 60	
	Size 60, 1-1/8 tvl	1H893826062		Rate 472	1F177327042
	Size 60, 1-1/2 tvl	1H893726062		Rate 630	1E826927042
	Size 76, 3/4 tvl	1N875126062		Rate 840	1E826627042
	Size 76, 1-1/8 tvl	1N875026062		Rate 1050	1E827227042
	Size 76, 1-1/2 tvl	1N874926062		Rate 1400	1E826827042
	Size 76, 2 tvl	1N874826062		Rate 1560	1E827127042
	Size 76, 2-3/8 tvl	1N190826062		Rate 1870	1E826327042
	Size 76, 2-1/2 tvl	1N190926062		Size 80 & 100	
	Size 76, 3 tvl	1N874726062		Rate 1000	1H747727042

Types 472, 473, 3572, 3573

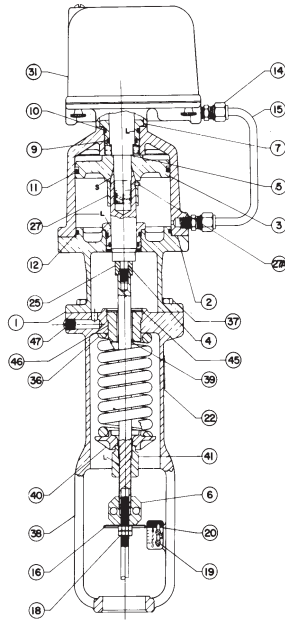

PARTS NOT SHOWN 13, 21, 23
DH9116 / DOC

Figure 12. Type 473, Size 60

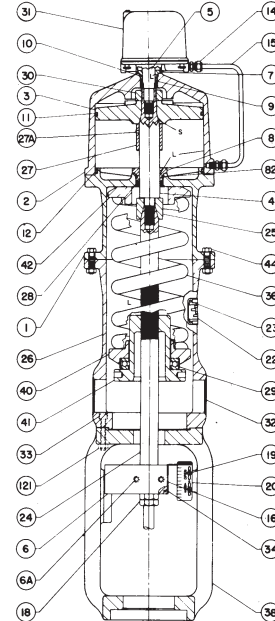

PARTS NOT SHOWN 13, 119, 120, 43
DK5325 / DOC

Figure 13. Type 473, Sizes 80-100

Key	Description	Part Number	Key	Description	Part Number
36	Spring, Steel (cont'd) Rate 1650 Rate 2100 Rate 2600 Rate 3100	1H747527042 1H747327042 1H747627042 1H747027042	40	Upper Spring Seat Steel Size 60 Type 472 Size 76 Type 472 Cast Iron Size 80 & 100 Type 472 Size 80 & 100 Type 473	1H607524092 2N912619052 1H945319052 2H946219052
37	Cap Screw, 6 req'd, Steel Size 60 Size 76, 78	1A336924052 1A7711X0082	43	Spring Retainer Spacer, 416 SST Size 78, 80, 100	1J223346172
38	Yoke, Cast Iron Size 60 Type 472 Size 60 Type 473 Size 76 Type 472 Size 76 & 78 Type 473 Size 80 & 100 Type 472 & 473	3E832319042 3E845919042 3N127319042 3N130319042 3K407919042	44	Cap Screw, Steel, 12 req'd Size 80, 100	1A514724052
40	Lower Spring Seat, Zinc Size 60 Size 76, 78 Size 80, 100	1R180023122 1N129619052 1H733019042	45	Snap Ring 302 SST Size 60	1E845638992
41	Spring Adjuster, Steel (Code Number Stamped on Flat of Hex Head) Type 472 Size 60 Code 1 Code 2 Code 3 Code 4 Code 5 Code 6 Type 473 Size 60 Code 1 Code 2 Code 3 Code 4 No Code	1H898224102 1H898324102 1H898424102 1H898524102 1H898624102 1H898724102 1J712224102 1J712324102 1J712424102 1J712524102 1E846224102	46	Spring Guide, Type 473 Size 60	1H915224092
			47	Pipe Plug, Type 473, Steel Size 60 Size 76, 78 Size 80	1B636624162 1A369224092 1H915224092
			77	Washer, Size 76, 78, Steel, 2 req'd	1E873028992
			78*	Cover Seal O-Ring, Syn Rubber, Size 76—472	1C853806992
			79	Cap Screw, Size 76, Type 472, Steel	1A344924052
			82*	Lower Bushing Seal O-Ring, Syn Rubber Size 80, 100	1C334206992
			119	Cap Screw, Steel, 8 req'd Size 80, 100	1A936224052
			120	Nut, 8 req'd Size 80, 100	1A343324122
			121	Nut, Steel, 18 req'd Size 80, 100 Type 473	1A341224122
			159	Pipe Plug, Steel Size 80, 100 Size 60 Type 472 Size 76 Type 472, 3/4 to 2 tvl Size 76 Type 472, 2-1/2 to 3 tvl Size 60 Type 473, 1-1/8 or less tvl	1A649528992 1E832424102 1N129424102 1N132524102 1J390724102

*Recommended spare parts

Types 472, 473, 3572, 3573

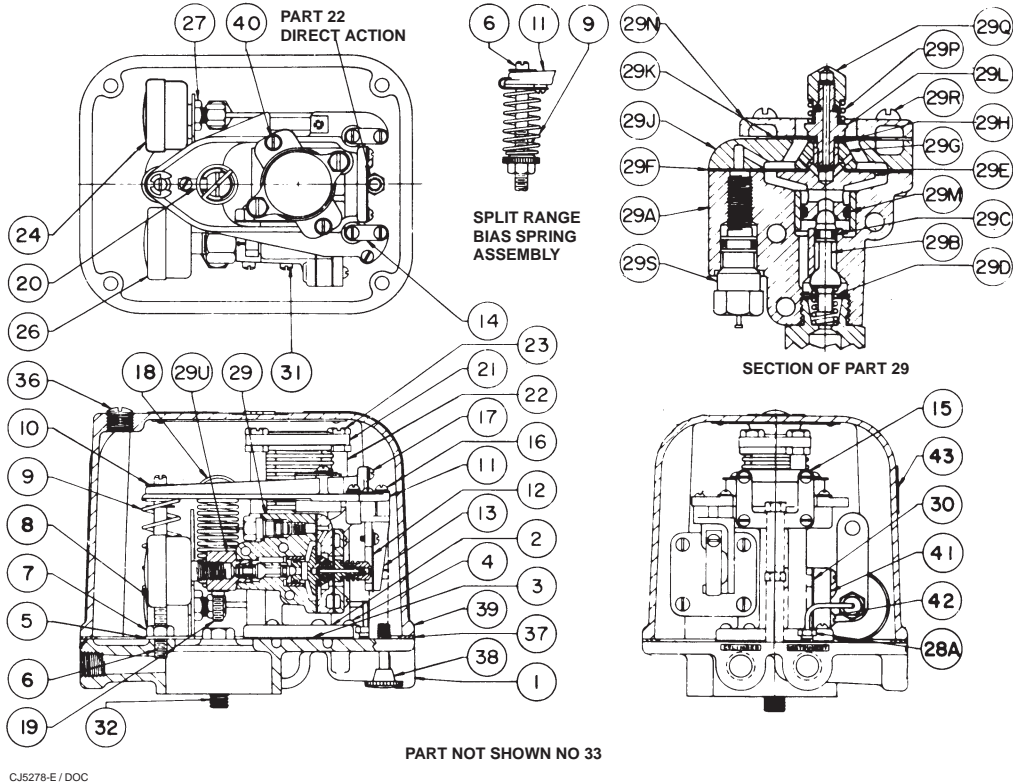

Figure 14. Type 3572 or 3573

Key	Description	Part Number	Key	Description	Part Number
159	Pipe Plug, Steel (cont'd)		19	Spring, Retainer, Steel—	Furnish Serial Number
	Size 60 Type 473, 1-1/2 or 2 tvl	1H899724102	20	Range Spring Lock, 302 SST	1H855136012
	Size 76 Type 473, 3/4 to 1-1/8 tvl	2N872324102	21*	Bellows Assy	
	Size 76 Type 473, 1-1/2 to 2 tvl	2N870924102		Up to 50 psi	1H8610000A2
	Size 76 Type 473, 3 tvl	2N870824102		Over 50 psi	1H9010000A2
			22	Bellows Post, Brass, 2 req'd	1H856614022
			23	Bellows Bolt, 2 req'd	1H856714022
			24*	Instrument Gauge	
				30 Lb Gauge	2H857699012
				60 Lb Gauge	2H857899012
			25*	Cylinder Bottom Gauge, 160 Lb	2H857599012
			26*	Cylinder Top Gauge, 160 Lb	2H857799012
			27	Gauge Mtg Nut, Brass, 2 req'd	1C724018992
			28A	Inst. Tubing Assy.	1H8612000A2
			28B	Cyl. Tubing Assy.	1H8611000A2
			29	Relay Assembly	
				Vertical Mounting (Type 3573)	AJ6205000A2
				Horizontal Mounting (Type 3572)	AJ6206000A2
			29A	Relay Body Assembly	1H8565000A2
			29B	Relay Valve, SST	1H855335032
			29C*	O-Ring, Syn Rubber, 2 req'd	1E2226X0012
			29D	Valve Spring, SST	1J468337022
			29E	Exhaust Port, Brass	1H855414012
			29F*	Relay Diaphragm, Syn Rubber	1H856302032
			29G	Relay Head Spacer, Brass	1H855614012
			29H	Relay Washer, Brass	1H855514012
			29J	Relay Spacer, Zinc	2H8574X0012
			29K*	Sealing Diaphragm, Syn Rubber	1H856202032
			29L	Relay Head Bolt, Brass	1H856114012
			29M*	O-Ring, Syn Rubber	1E216306992
			29N	Relay Flange, Zinc	17A0963X012
			29P	Nozzle Spring, Steel	1A594127012

Types 472, 473, 3572, 3573

Key	Description	Part Number	Key	Description	Part Number
29Q	Nozzle, SST	1H856035032	37*	Cover Gasket, Composition	1H853804042
29R	Relay Flange Screw, Steel, 4 req'd	1A519928992	38	Cover Screw, Steel, 4 req'd	1H854128992
29S	Restriction Plug & Wire Assy	12B1537X022	39A	Cover, Aluminum	3H858308022
29T	Body Cap (Vertical Relay), Brass	1B797514022	39B	Nameplate, Aluminum	2H860911032
29U	Gauge Adaptor (Horizontal Relay), Brass	1H855814022	40	Bellows End Washer, Brass, 2 req'd	1H339718992
30*	Relay Gasket, Syn Rubber, 2 req'd	1H855903012	41	Relay Blank, Aluminum	1J314907012
31	Relay Mtg Screw, Steel, 3 req'd	1H856928992	42	Relay Blank Screws, Steel, 3 req'd	1A519928992
32	Positioner Mtg Screw, Steel	1A782024052	43	Positioner Action Label, Paper	
33*	Positioner Mtg Seal, Syn Rubber	1C8538X0022		Direct Action	1J600706032
36	Pipe Plug, Steel	1B636624162		Reverse Action	1J600806032

Types 472, 473, 3572, 3573

Fisher, Fisher-Rosemount, and Managing The Process Better are marks owned by Fisher Controls International, Inc. or Fisher-Rosemount Systems, Inc. All other marks are the property of their respective owners.

©Fisher Controls International, Inc. 1998; All Rights Reserved

The contents of this publication are presented for informational purposes only, and while every effort has been made to ensure their accuracy, they are not to be construed as warranties or guarantees, express or implied, regarding the products or services described herein or their use or applicability. We reserve the right to modify or improve the designs or specifications of such products at any time without notice.

For information, contact Fisher Controls:
Marshalltown, Iowa 50158 USA
Cernay 68700 France
Sao Paulo 05424 Brazil
Singapore 128461

