

Fisher™ SS-138B and SS-252B Rotary Ball Valves

Introduction

This special instruction manual is an addendum to the Fisher Vee-Ball™ V150, V200, and V300 Rotary Control Valves NPS 1 through 12 Instruction Manual ([D101554X012](#)). Observe all Warnings, Cautions, and Notes provided in the instruction manual. A copy of the manual is attached to this special instruction manual for your reference.

Scope

This special instruction manual provides the assembly, disassembly, and parts information of the seal shims and seal assembly for the SS-252B, and of the seal shims and flow ring construction for the SS-138B. For other procedures, refer to the Fisher Vee-Ball V150, V200, and V300 Rotary Control Valves NPS 1 through 12 Instruction Manual (D101554X012).

Do not install, operate, or maintain SS-138B and SS-252B rotary ball valves without being fully trained and qualified in valve, actuator, and accessory installation, operation, and maintenance. To avoid personal injury or property damage, it is important to carefully read, understand, and follow all the contents of this manual, including all safety cautions and warnings. If you have any questions about these instructions, contact your [Emerson sales office](#) before proceeding.

Description

The SS-138B valve, a modified V200 or V300, has a metal flow ring construction with a V-notch ball adjusted by shimming to the center of the valve body cavity to hold the flow ring 0.254 to 0.508 mm (0.010 to 0.020 inch) away from the ball.

The SS-252B valve, a modified V300, has a stellite metal seal with a V-notch ball adjusted by shimming to the center of the valve body cavity to obtain zero ball seal deflection. The maximum allowable leakage rates (scfh) for this valve are 400 for NPS 2, 500 for NPS 3, 800 for NPS 4, and 1100 for NPS 6.

Educational Services

For information on available courses for Fisher SS-138B and SS-252B rotary ball valves, as well as a variety of other products, contact:

Emerson Automation Solutions
Educational Services - Registration
Phone: 1-641-754-3771 or 1-800-338-8158
E-mail: education@emerson.com
emerson.com/fishervalvetraining

Figure 1. Detail of Fisher SS-252B Metal Seal with Multiple Springs

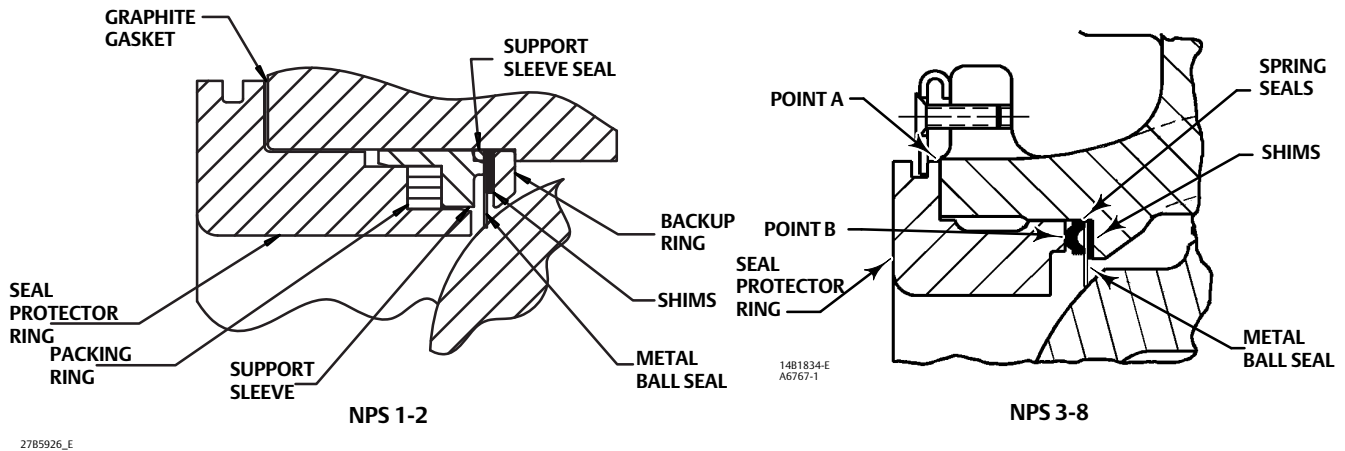

Assembly of Metal Ball Seal with Multiple Spring Seals for SS-252B

⚠ WARNING

When the actuator is removed from the valve, the Vee-Ball/shaft assembly may suddenly rotate, resulting in personal injury. To avoid injury, carefully rotate the ball to the bottom of the valve body cavity. Make sure the ball will not rotate.

1. Install the seal shims in the valve, and install the seal on top of the seal shims. Add or remove shims under the seal as necessary to obtain zero ball seal deflection.

Note

Zero ball seal deflection is the point at which the addition of one 0.13 millimeter (0.005-inch) thick shim causes contact between the ball and ball seal to be broken. Hold the parts tightly together when determining zero deflection, or improper zero deflection might result.

2. Add five spring seals on top of the metal seal, then install the seal protector ring.

Note

Make the following measurement before compressing the spring seals for the first time.

3. Measure the distance at point "A" (figure 1 in this special manual) between the seal protector ring and the valve body.
 - a. Add a spring seal at point "B" if the measurement is less than 0.635 mm (0.025 inch) at point "A".
 - b. If necessary, add additional spring seals at point "B" until the measurement is 0.635 to 1.27 mm (0.025 to 0.050 inch).

4. Remove the seal protector ring, and add the flexible graphite gasket between the valve body and seal protector ring.
5. Install the seal protector clips, or washers, and seal protector screws (keys 21 and 22) to secure the seal protector ring to the valve body.
6. Refer to the Fisher Vee-Ball V150, V200, and V300 NPS 1 through 12 Instruction Manual ([D101554X012](#)) to continue the reassembly of the valve.

Figure 2. Fisher SS-138B Seal Details

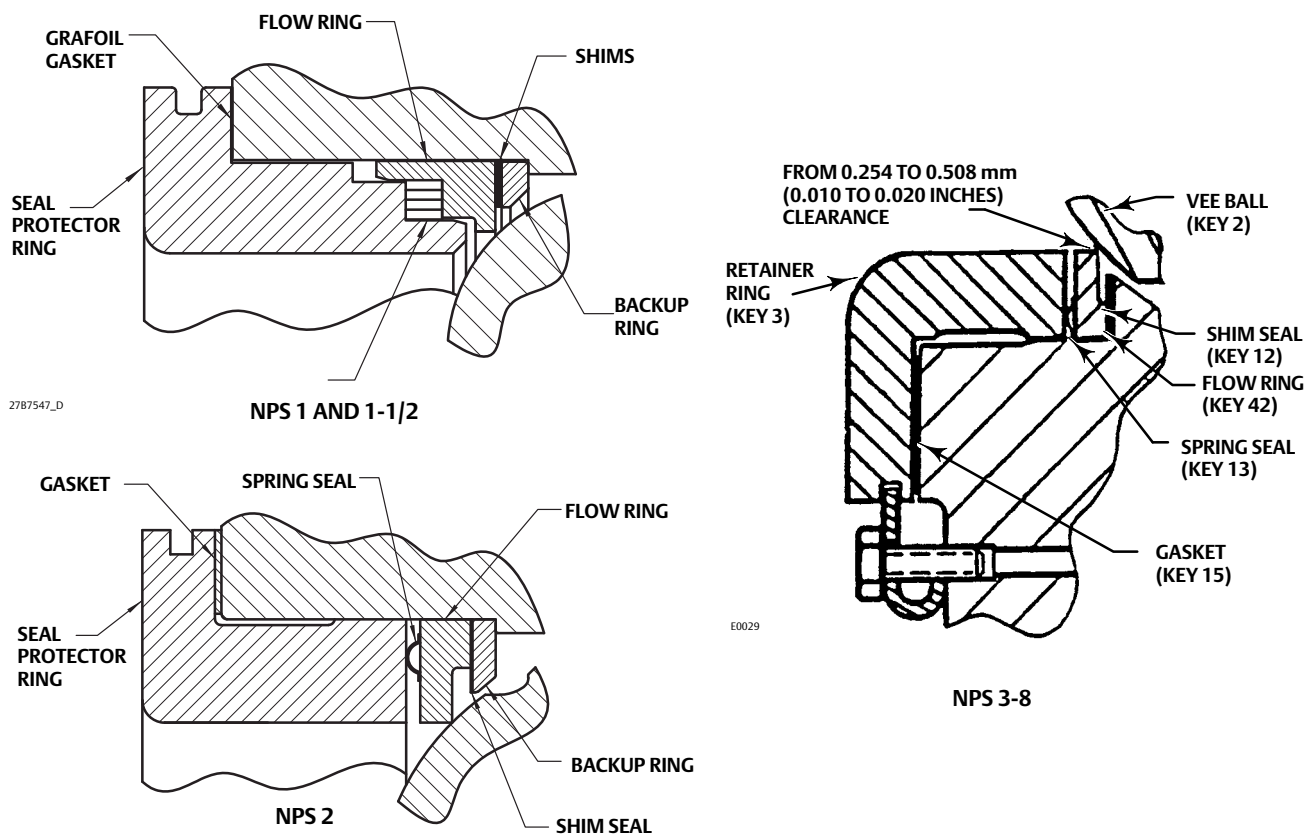

Removing the Flow Ring Construction for SS-138B

⚠ WARNING

When the actuator is removed from the valve, the Vee-Ball/shaft assembly may suddenly rotate, resulting in personal injury. To avoid injury, carefully rotate the ball to the bottom of the valve body cavity. Make sure the ball will not rotate.

Please observe all the Warnings, Cautions, and Notes in the Maintenance section of the Fisher Vee-Ball V150, V200, and V300 Instruction Manual ([D101554X012](#)).

1. Isolate the control valve from the line pressure, release pressure and drain the process media from both sides of the valve. If using a power actuator, shut off all pressure/power lines to the power actuator and release all pressure from the actuator.
2. If not already accomplished, remove the line bolting, remove the valve from the pipeline, and place the actuator/valve assembly on a protected flat surface with the seal protector ring facing up. Provide a method of rotating the ball to the open position.
3. Remove the cap screws and spring clips (keys 21 and 22) that hold the retainer ring (key 3) in place. Carefully lift the ring out of the valve body.
4. Remove the spring seal, flow ring, and shim seals (keys 13, 42, and 12). Check all parts for damage and replace parts, if necessary.
5. If no further disassembly is required, continue with the assembly steps below.

Replacing the Flow Ring Construction for SS-138B

⚠ WARNING

When the actuator is removed from the valve, the Vee-Ball/shaft assembly may suddenly rotate, resulting in personal injury. To avoid injury, carefully rotate the ball to the bottom of the valve body cavity. Make sure the ball will not rotate.

1. If not already accomplished, place the valve/actuator assembly on a protected surface with the flow ring side facing up. Provide a means of rotating the ball to the closed position.
2. Install 12 seal shims (key 12) at the seal ledge (see figure 3).
3. Install the flow ring (key 42), making certain it is centered and does not contact the ball.
4. Secure with the retainer ring (key 3) with cap screws and retainer clip (keys 21 and 22) and tighten the cap screws. Measure the clearance between the flow ring and the ball with a wire gauge.
5. Add or subtract seal shims until obtaining the minimum clearance between the ball and flow ring. The clearance should be between 0.254 to 0.508 mm (0.010 to 0.020 inch)

Installing the Bearing Shims

The bearing shims should be installed after the drive shaft and ball have been installed. Please observe all the **Warnings, Cautions, and Notes** in the Replacing the Ball Seal portion of the Maintenance section of the Fisher Vee-Ball V150, V200, and V300 Instruction Manual ([D101554X012](#)).

1. Insert the follower shaft into the ball ear only until it reaches the far side of the ball ear.
2. Install one shim (key 43) between the thrust washer (applicable for NPS 1, 1-1/2, and 2) and the ball ear right where the follower shaft will exit the ball.
3. Push the follower shaft through the shim and into the bearing, making sure to line up the taper key holes.

Repeat this process until ball movement is less than 0.10 mm (0.004 inch) (within one shim).

Parts List

The following list only covers the seal assembly for these valves. For all other parts please refer to the Fisher Vee-Ball V150, V200, and V300 Instruction Manual ([D101554X012](#)).

⚠ WARNING

Use only genuine Fisher replacement parts. Components that are not supplied by Emerson Automation Solutions should not, under any circumstances, be used in any Fisher valve, because they may void your warranty, might adversely affect the performance of the valve, and could cause personal injury and property damage.

Key	Description	Key	Description
Note			
Contact your Emerson sales office for Part Ordering information.			
2	Ball	12*	Shim Seal (12 req'd) (unless otherwise noted) (10 req'd for NPS 1 and 1-1/2)
3	Protector Ring	13*	Spring Seal (1 req'd for SS-138B, NPS 2-8) (5 req'd for SS-252B, NPS 3-8)
6	Drive Shaft	21	Seal Protector Screw (2 req'd)
7*	Groove Pin	22	Seal Protector Clip (2 req'd)
9	Follower Shaft	23	Actuator Mounting Screw
11*	Ball Seal	24	Actuator Mounting Nut
		26	Manufacturers Tag
		42	Flow Ring
		43	Bearing Shim (12 req'd)
		48	Ball / Shaft Assembly

Figure 3. Fisher SS-138B Valve Assembly (Details Are Typical for SS-252B Also, Except for Seal Area)

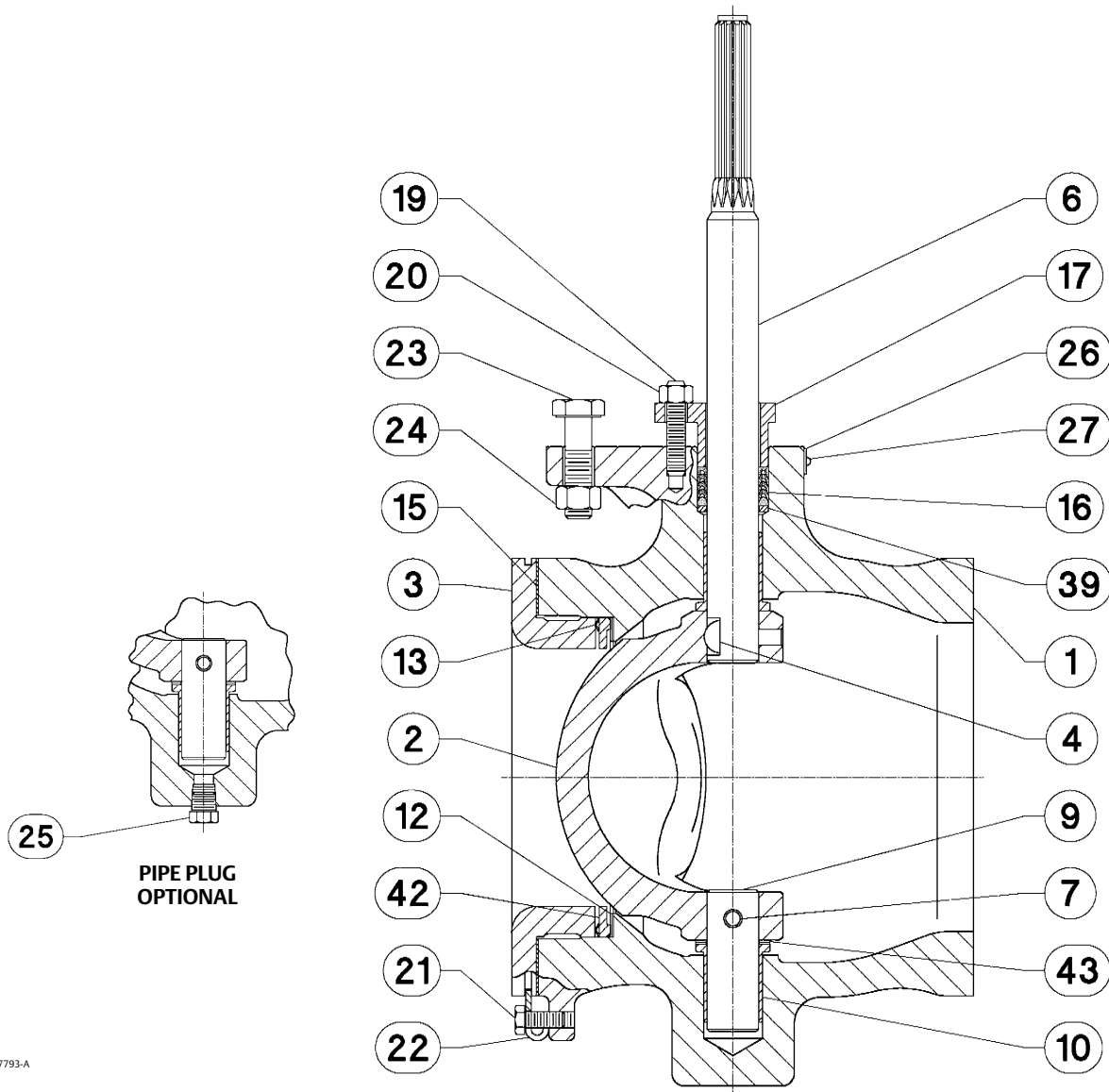

4887793-A

Neither Emerson, Emerson Automation Solutions, nor any of their affiliated entities assumes responsibility for the selection, use or maintenance of any product. Responsibility for proper selection, use, and maintenance of any product remains solely with the purchaser and end user.

Fisher and Vee-Ball are marks owned by one of the companies in the Emerson Automation Solutions business unit of Emerson Electric Co. Emerson Automation Solutions, Emerson, and the Emerson logo are trademarks and service marks of Emerson Electric Co. All other marks are the property of their respective owners.

The contents of this publication are presented for informational purposes only, and while every effort has been made to ensure their accuracy, they are not to be construed as warranties or guarantees, express or implied, regarding the products or services described herein or their use or applicability. All sales are governed by our terms and conditions, which are available upon request. We reserve the right to modify or improve the designs or specifications of such products at any time without notice.

Emerson Automation Solutions
Marshalltown, Iowa 50158 USA
Sorocaba, 18087 Brazil
Cernay 68700 France
Dubai, United Arab Emirates
Singapore 128461 Singapore

www.Fisher.com

