

January 2010

# Y692VB Series Vacuum Breakers

## Introduction

### Scope of the Manual

This manual provides instructions and a parts list for Types Y692VB and Y692VBM vacuum breakers. Instructions and parts lists for other equipment used with these breakers are found in separate manuals.

### Product Description

The Y692VB Series vacuum breakers are used for precise control of small capacity, low-pressure service applications where an increase in vacuum must be limited. These direct-operated vacuum breakers come in NPS 1-1/2 and 2 (DN 40 and 50) body sizes and have a 3/4 or 1-3/16-inch (19 or 30 mm) orifice and a 3/4-inch (19 mm) spring case vent connection with optional umbrella vent assembly. The products are described as follows:

**Type Y692VB**—Type Y692VB has internal pressure registration, so it does not require a control line.

**Type Y692VBM**—Type Y692VBM has a control line connection and an O-ring stem seal to block the throat for external pressure registration.

### Specifications

Some general ratings and specifications for the Y692VB Series vacuum breakers are given on page 2. Individual vacuum breakers come from the factory with the specific data stamped on the nameplate.

### Installation



**WARNING**

**Personal injury, property damage, equipment damage, or leakage due to escaping gas or bursting of pressure-containing parts may result if this**

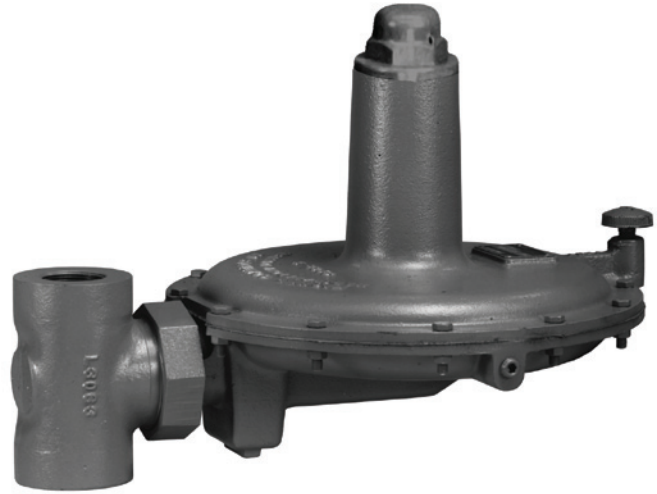

W7429

*Figure 1. Type Y692VB Vacuum Breaker*

**equipment is overpressured or is installed where service conditions could exceed the limits given in the Specifications, or where conditions exceed any ratings of the adjacent piping or piping connections. To avoid such injury or damage, provide pressure-relieving or pressure-limiting devices (as required by the appropriate code, regulation, or standard) to prevent service conditions from exceeding those limits. Additionally, physical damage to this equipment could cause personal injury or property damage due to escaping gas. To avoid such injury or damage, install the equipment in a safe and well-ventilated location.**

Equipment operation within ratings does not preclude the possibility of damage from debris in the lines or from external sources. This equipment should be inspected for damage periodically and after any overpressure condition.



[www.fisherregulators.com](http://www.fisherregulators.com)



# Y692VB Series

## Specifications

<p><b>Body Sizes</b> NPS 1-1/2 or 2 (DN 40 or 50)</p> <p><b>End Connection Styles<sup>(1)</sup></b> See Table 1</p> <p><b>Maximum Allowable Inlet (Positive) Pressure<sup>(2)</sup> and Orifice Sizes</b>  <b>3/4-inch (19 mm) Orifice:</b> 30 psig (2,1 bar)  <b>1-3/16-inch (30 mm) Orifice:</b> 13 psig (0,90 bar)</p> <p><b>Vacuum Control Pressure Ranges<sup>(2)</sup></b> See Table 2</p> <p><b>Maximum Casing Pressure<sup>(2)</sup></b> 8 psig (0,55 bar) Vacuum</p> <p><b>Change in Vacuum Control Pressure to Reach Wide-Open<sup>(2)</sup></b> See Table 2</p> <p><b>Pressure Registration</b>  <b>Type Y692VB:</b> Internal  <b>Type Y692VBM:</b> External</p>	<p><b>Spring Case Connection</b> 3/4 NPT</p> <p><b>Type Y692VB Gauge Tap Connection</b> 1/4 NPT</p> <p><b>Type Y692VBM Control Line Connection</b> 1/2 NPT</p> <p><b>Temperature Capabilities<sup>(2)</sup></b>  <b>Nitrile (NBR):</b> -40° to 180°F (-40° to 82°C)  <b>Fluorocarbon (FKM):</b>  40° to 300°F (4° to 149°C)  <b>Ethylenepropylene (EPR):</b>  -20° to 200°F (-29° to 93°C)  <b>Perfluoroelastomer (FFKM):</b>  0° to 300°F (-18° to 149°C)  <b>Silicone:</b> -40° to 400°F (-40° to 204°C)</p> <p><b>Approximate Weight</b>  <b>Cast Iron:</b> 45 pounds (20 kg)  <b>Steel, Stainless Steel, or Hastelloy® C:</b>  57 pounds (26 kg)</p>
---	--

1. End connections for other than U.S. standards can usually be provided; consult your local Sales Office.  
2. The pressure/temperature limits in this Instruction Manual and any applicable standard or code limitation should not be exceeded.

**Table 1. End Connection Styles**

BODY SIZE, NPS (DN)	CONSTRUCTION MATERIAL AND END CONNECTION STYLE <sup>(1)</sup>		
	Cast Iron	Steel or Stainless Steel	Hastelloy® C
1-1/2 (40)	NPT	NPT, SWE, CL150 RF,	CL150 RF
2 (50)	NPT or CL125 FF	CL300 RF, or PN 16/25/40	

1. All flanges are welded on to the body and have a face-to-face dimension of 14-inches (356 mm).

**Table 2. Vacuum Pressure Information**

VACUUM CONTROL PRESSURE RANGE <sup>(1)</sup>	CHANGE IN VACUUM CONTROL PRESSURE TO REACH WIDE-OPEN	SPRING PART NUMBER	SPRING COLOR	SPRING WIRE DIAMETER, INCHES (mm)	SPRING FREE LENGTH, INCHES (mm)
1 to 3-inches w.c. (2 to 7 mbar) <sup>(2)</sup>	1.2-inches w.c. (3 mbar)	1D892527022	Brown	0.109 (2,77)	6.12 (155)
3 to 8-inches w.c. (7 to 20 mbar) <sup>(2)</sup>	4.0-inches w.c. (10 mbar)	0B019727052	Purple	0.148 (3,76)	6.00 (152)
8 to 16-inches w.c. (20 to 40 mbar)	5.0-inches w.c. (13 mbar)	1B766627062	Gray	0.156 (3,96)	6.62 (168)
16 to 32-inches w.c. (40 to 80 mbar)	10.5-inches w.c. (26 mbar)	1B883327022	Unpainted	0.187 (4,75)	6.62 (168)
0.25 to 3 psig (17 mbar to 0,21 bar)	2 psig (0,14 bar)	1A630627022	Black	0.275 (6,99)	5.25 (133)

1. Pressure ranges are based on the spring case pointing up. Pointing the spring case down increases the pressure range 1.7-inches w.c. (4 mbar). (Example: 1 to 3-inches w.c. (2 to 7 mbar) changes to 2.7 to 4.7-inches w.c. (7 to 12 mbar)).  
2. Do not use fluorocarbon (FKM) with these springs at diaphragm temperatures lower than 40°F (4°C).

### Note

**If this equipment is shipped mounted on another unit, install that unit according to the appropriate instruction manual.**

this unit. Before installing the vacuum breaker, make sure the unit was not damaged during shipping and that it does not contain any foreign material. Also ensure that all tubing and piping have been blown free.

1. Only personnel qualified through training and experience should install, operate, and maintain
2. This unit may be installed in any position as long as the flow through the body is in the direction

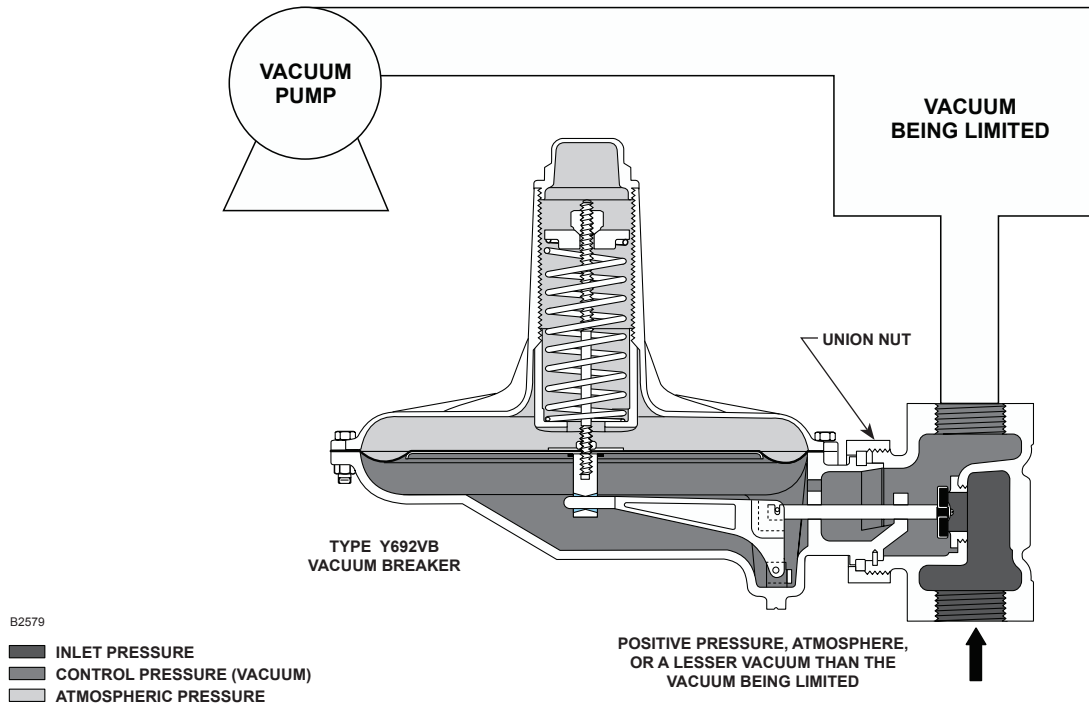

Figure 2. Operational Schematic

indicated by the arrow cast on the body. If continuous operation is required during inspection or maintenance, install a three-valve bypass around the equipment.



## WARNING

**This equipment may vent some gas to the atmosphere. In hazardous or flammable gas service, vented gas may accumulate and cause personal injury, death, or property damage due to fire or explosion. Vent equipment in hazardous gas service to a remote, safe location away from air intakes or any hazardous area. The vent line or stack opening must be protected against condensation or clogging.**

## Principle of Operation

An increase in vacuum (decrease in absolute pressure) beyond the setpoint registers on the diaphragm, opening the disk. This permits body inlet pressure to enter the system and restore the controlled vacuum to the setpoint. On Type Y692VB, the pressure at the regulator body outlet registers

directly into the diaphragm casing. Type Y692VBM has a control line connecting the diaphragm casing to the vacuum being controlled and an O-ring stem seal blocking the throat allowing for registration only through the control line connection (outlet body pressure may or may not be the same as the pressure in the diaphragm casing).

## Startup and Adjustment

All Y692VB Series vacuum breakers can be placed in operation by slowly introducing inlet pressure. The unit takes control when vacuum is established. This equipment is suitable for the vacuum control pressure range stamped on the nameplate (key 50, Figure 5). To adjust the pressure setting, remove the closing cap (key 3) and turn the adjusting nut (key 2) clockwise to increase the pressure setting or counterclockwise to decrease the setting. Replace the closing cap after adjustment. The closing cap may be wired to the hole provided in the spring case (key 23) to discourage tampering.

## Shutdown

To shut down the unit, close the upstream shut-off valve, and then close the downstream shut-off valve to vent the equipment properly. Next, open the vent valve

# Y692VB Series

between the equipment and the downstream shut-off valve nearest to it. All pressure between these shut-off valves is released through the open vent valve.

## Maintenance

Vacuum breaker parts are subject to normal wear and must be inspected and replaced as necessary. Inspection frequency and replacement of parts depends on the severity of service conditions, applicable codes, government regulations, and company standards.



### WARNING

**To avoid personal injury, property damage, or equipment damage caused by sudden release of pressure or explosion of accumulated gas, do not attempt any maintenance or disassembly without first isolating the vacuum breaker from system pressure and relieving all internal pressure.**

## Body Area

The following procedure is for gaining access to the disk assembly, orifice, and body gasket. Release all pressure from the diaphragm case before performing the following steps. Key numbers are referenced in Figures 3 and 4.

1. To inspect and replace the disk holder assembly (key 25) or orifice (key 27), loosen the union nut (key 19). Tip the diaphragm casing (key 20) toward the outlet and separate it from the body (key 28).
2. Remove and inspect the body gasket (key 16).
3. Inspect the orifice (key 27) and replace it if necessary. Lightly grease the orifice threads and install it using 29 to 37 foot-pounds (39 to 50 N•m) of torque.
4. Remove the cotter pin (key 14) if it is necessary to replace the disk holder assembly (key 25).

### Note

**The disk holder assembly (key 25) is comprised of the disk and disk holder. A washer (key 46) and machine screw (key 47) are required to complete the assembly.**

5. Install the disk holder assembly (key 25). Use the cotter pin (key 14) to secure it to the valve stem (key 13).
6. If necessary, install a replacement body gasket (key 16) into the body (key 28).
7. Slide the union nut (key 19) onto the diaphragm casing (key 20) as far as it will go. Install both halves of the split ring (key 17) into the slots of the diaphragm casing and secure them by sliding the union nut over the split ring.
8. Install the diaphragm casing (key 20) by tightening the union nut (key 19) until the diaphragm casing is secure on the body (key 28).

## Diaphragm and Spring Case Area

This procedure is for gaining access to the control spring, diaphragm assembly, valve stem, and stem O-ring. Release all pressure from the diaphragm case before performing the following steps.

### Type Y692VB

Key numbers are referenced in Figure 3.

1. Remove the closing cap (key 3) and turn the adjusting nut (key 2) counterclockwise until all compression is removed from the control spring (key 1). If the only further maintenance is to change the control spring (key 1), skip to step 11.
2. Remove the cap screws (key 21) and hex nuts (key 22) and lift off the spring case assembly (key 23).
3. Remove the diaphragm (key 5) and attached parts by tilting it so that the pusher post (key 8) slips off the lever assembly (key 9). To separate the diaphragm from the attached parts, unscrew the diaphragm hex nut (key 37). If the only further maintenance is to replace the diaphragm parts or change the control spring (key 1), skip to step 8.
4. To replace the lever assembly (key 9), remove the machine screws (key 11).
5. To replace the valve stem (key 13), perform Body Area Maintenance procedure steps 1 through 4 and pull the valve stem out of the diaphragm casing (key 20).
6. Install the valve stem (key 13) into the diaphragm casing (key 20) and perform Body Area Maintenance procedure steps 5 through 8.

7. Install the lever assembly (key 9) into the valve stem (key 13) and secure the lever assembly (key 9) with the machine screws (key 11).
8. Install the lower head gasket (key 7), lower diaphragm head (key 24), diaphragm (key 5), and upper diaphragm head (key 6) on the pusher post (key 8) and attach with the diaphragm hex nut (key 37). Tighten using 30 to 45 foot-pounds (41 to 61 N•m) of torque.
9. Install the pusher post (key 8) plus attached diaphragm parts onto the lever assembly (key 9).
10. Install the spring case assembly (key 23) and control spring (key 1) on the diaphragm casing (key 20) so that the vent assembly is correctly oriented, and secure them with the cap screws (key 21) and hex nuts (key 22), finger tight only.
11. Install the upper spring seat (key 44) and the adjusting nut (key 2) turning clockwise until there is enough control spring (key 1) force to provide proper slack to the diaphragm (key 5) and attached parts. Using a crisscross pattern, finish tightening the cap screws (key 21) and hex nuts (key 22) using 55 to 75 inch-pounds (6 to 8 N•m) of torque. Then finish turning the adjusting nut to the desired outlet pressure setting.
12. Install a replacement closing cap gasket (key 35) if necessary, and then install the closing cap (key 3).
4. To replace the lever assembly (key 9), remove the machine screws (key 11).
5. To replace the valve stem (key 13) or stem seal O-ring (key 15) perform Body Area Maintenance procedure steps 1 through 4 and pull the valve stem out of the diaphragm casing (key 20).
6. Lightly grease the replacement stem seal O-ring (key 15) with a good grade of elastomer lubricant and install on the valve stem (key 13). Install the valve stem by pushing it into the diaphragm casing and perform Body Area Maintenance procedure step 5, and step 8 if necessary.
7. Install the lever assembly (key 9) into the valve stem (key 13) and secure the lever assembly (key 9) with the machine screws (key 11).
8. Install the lower head gasket (key 7), lower diaphragm head (key 24), diaphragm (key 5), and upper diaphragm head (key 6) on the pusher post (key 8) and attach with the diaphragm hex nut (key 37). Tighten using 30 to 45 foot-pounds (41 to 61 N•m) of torque.
9. Install the pusher post (key 8) plus attached diaphragm parts onto the lever assembly (key 9).
10. Install the spring case assembly (key 23) and control spring on the diaphragm casing (key 20) so that the vent assembly (key 65, not shown) is correctly oriented, and secure them with the cap screws (key 21) and hex nuts (key 22), finger tight only.

## Type Y692VBM

Key numbers are referenced in Figures 3 and 4.

1. Remove the closing cap (key 3) and turn the adjusting nut (key 2) counterclockwise until all compression is removed from the control spring (key 1).
2. Remove the spring case cap screws (key 21) and hex nuts (key 22) and lift off the spring case assembly (key 23). If the only further maintenance is to change the control spring (key 1), skip to step 10.
3. Remove the diaphragm (key 5) and attached parts by tilting it so that the pusher post (key 8) slips off the lever assembly (key 9). To separate the diaphragm (key 5) from the attached parts, unscrew the diaphragm hex nut (key 37). If the only further maintenance is to replace the diaphragm parts or change the control spring (key 1), skip to step 8.
11. Turn the adjusting nut (key 2) clockwise until there is enough control spring (key 1) force to provide proper slack to the diaphragm (key 5) and attached parts. Using a crisscross pattern, finish tightening the cap screws (key 21) and hex nuts (key 22) to 55 to 75 inch-pounds (6 to 8 N•m) of torque. Then finish turning the adjusting nut to the desired outlet pressure setting.
12. Install a replacement closing cap gasket (key 35) if necessary, and then install the closing cap (key 3).

## Parts Ordering

When corresponding with your local Sales Office about this regulator, include the type number and all other pertinent information stamped on the closing cap (key 3) or nameplate (key 50). Specify the eleven-character part number when ordering new parts from the following parts list.



# Y692VB Series

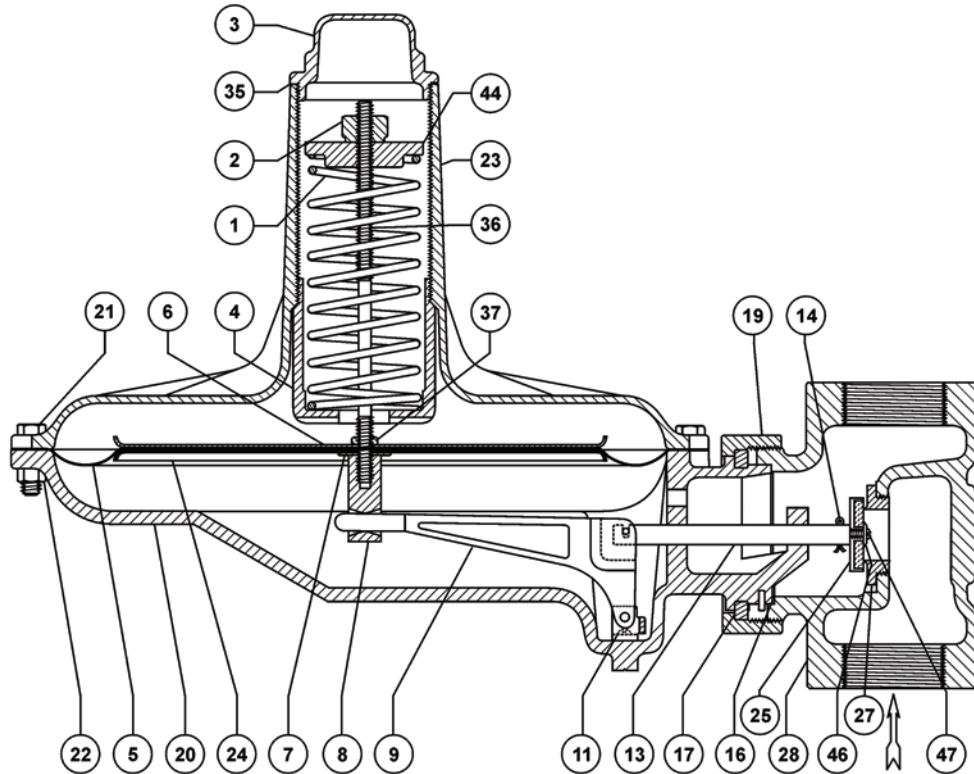

A7178

Figure 3. Y692VB Series Assembly

Table 3. Body Materials and Part Numbers (Key 28)

BODY SIZE AND END CONNECTION STYLE		MATERIAL			
		Cast Iron	WCB Steel	WCB Steel (NACE)	CF8M Stainless Steel
NPS 1-1/2 (DN 40)	NPT	1B403619012	2L244522012	----	2L244533092
	SWE	----	2E2291X0012	----	----
	CL150 RF	----	14B3208X262	14B3208X252	14B3208X272
	CL300 RF	----	14B3208X022	14B3208X242	14B3208X052
	PN 16/25/40	----	14B3208X072	14B3208X222	14B3208X092
NPS 2 (DN 50)	NPT	1B403719012	2L243322012	----	2L2433X00A2
	SWE	----	2H562322012	----	----
	CL125 FF	2D986519012	----	----	----
	CL150 RF	----	14B3208X012	14B3208X202	14B3208X042
	CL300 RF	----	14B3208X032	14B3208X162	14B3208X062
	PN 16/25/40	----	14B3208X082	14B3208X232	14B3208X102

## Parts List

Key	Description	Part Number	Key	Description	Part Number
1	Spring 1 to 3-inches w.c. (2 to 7 mbar) 3 to 8-inches w.c. (7 to 20 mbar) 8 to 16-inches w.c. (20 to 40 mbar) 16 to 32-inches w.c. (40 to 80 mbar) 0.25 to 3 psig (17 mbar to 0,21 bar)	1D892527022 0B0197000A2 1B766627062 1B883327022 0B019727052	5*	Diaphragm Nitrile (NBR) Fluorocarbon (FKM) Ethylenepropylene (EPR) Silicone	0R032502052 0R0325X0032 0R0325X0062 0R0325X0082
2	Adjusting Nut	1A201914012	6	Upper Diaphragm Head	0B006628982
3	Closing Cap	1L928308012	7*	Lower Head Gasket	1L143403022
4	Lower Spring Seat	1U226019012	8	Pusher Post, Stainless steel	0Y096435072
			9	Lever Assembly	1E3409X0052

\*Recommended Spare Parts

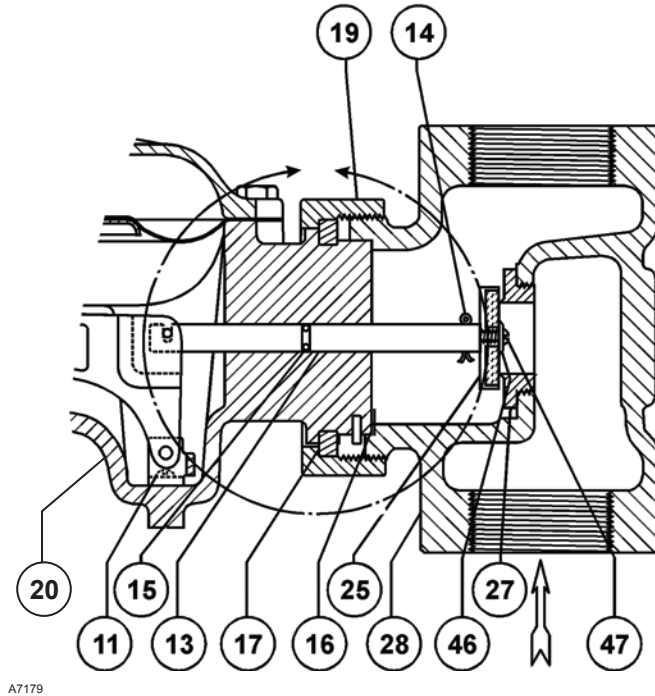

Figure 4. Type Y692VBM O-Ring Stem Seal Detail

Key	Description	Part Number	Key	Description	Part Number
11	Machine Screw (2 Required) Standard NACE	1A866935032 1A8669X0012	22	Hex Nut (12 required) Standard NACE	1A309324122 1A309338992
13	Valve Stem Standard NACE	1E767635032 1E7676X0012	23	Spring Case Cast iron WCB Steel CF8M Stainless steel Aluminum	2B155719042 34B2157X012 34B2157X042 AE6180X0012
14*	Cotter Pin Standard NACE	1A866537022 1A8665X00A2	24	Lower Diaphragm Head	1A3478X0022
15*	O-Ring (Stem Seal for Type Y692VBM only) Nitrile (NBR) Fluorocarbon (FKM) Ethylene propylene (EPR) Perfluoroelastomer (FFKM)	1E472706992 1N430406382 1D6875X0032 1D6875X0082	25*	Disk Holder Assembly Standard Trim Nitrile (NBR) Fluorocarbon (FKM) Polytetrafluoroethylene (PTFE) NACE Trim Neoprene (CR) Fluorocarbon (FKM) Perfluoroelastomer (FFKM) PTFE Ethylene propylene (EPR)	1C7831X0072 1C7831X0092 1C7831X0112 1C7831X0152 1C7831X0162 1C7831X0202 1C7831X0212 1C7831X0222
16*	Body Gasket	1A348004032	27	Orifice Standard 3/4-inch (19 mm) 1-3/16-inch (30 mm) NACE 3/4-inch (19 mm) 1-3/16-inch (30 mm)	1B816935032 15A6822X012 1B8169X0012 15A6822X022
17	Split Ring	0Y095828982	28	Body	See Table 3
19	Union Nut Cast iron body WCB Steel body CF8M Stainless steel body	0Z0176X0032 0Z017624092 0Z0176X0012	29	Pipe Plug (Use on Type Y692VB) Cast iron and steel lower casings (NACE) Stainless steel lower casing	1C333528992 1C3335X0012
20	Diaphragm Casing Type Y692VB Cast iron WCB Steel Standard NACE CF8M Stainless steel Type Y692VBM WCB Steel CF8M Stainless steel	3B973519012 3F191622012 3F1916X0022 3F191633092 39A7502X022 39A7502X012	35*	Closing Cap Gasket	1N446206992
21	Cap Screw (12 required) Standard NACE	1B136324052 1B136338992	36	Adjusting Stem	1A626314012

\*Recommended Spare Parts

# Y692VB Series

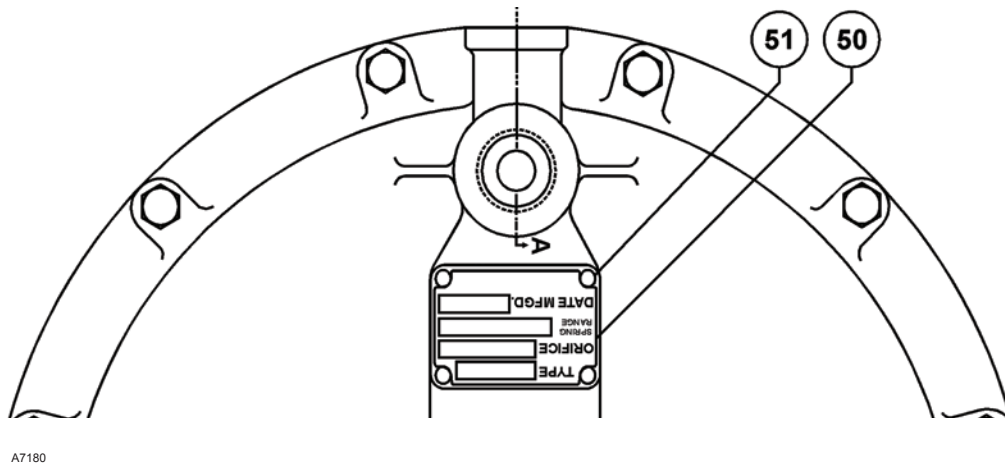

Figure 5. Y692VB Series Detail

Key	Description	Part Number	Key	Description	Part Number
37	Diaphragm Hex Nut	1A499724122	47	Machine Screw	19A7151X022
44	Upper Spring Seat 1 to 16-inches w.c. (2 to 40 mbar) 16-inches w.c. to 3 psig (40 mbar to 0,21 bar)	1A869524092 1A626424092	51	Drive Screw	1A368228982
46	Valve Disk Washer Standard Trim NACE Trim	0X014635032 0X0146X0012	56	Vent Assembly, Y602X1-11 (not shown)	17A5515X012
			71	Pipe Bushing (not shown)	1A3424X0042
			95	NACE Tag (NACE Construction only, not shown)	19A6034X012
			96	Tag Wire (NACE Construction only, not shown)	1U7581X0022

## Industrial Regulators

### Emerson Process Management Regulator Technologies, Inc.

USA - Headquarters  
McKinney, Texas 75069-1872 USA  
Tel: 1-800-558-5853  
Outside U.S. 1-972-548-3574

Asia-Pacific  
Shanghai, China 201206  
Tel: +86 21 2892 9000

Europe  
Bologna, Italy 40013  
Tel: +39 051 4190611

Middle East and Africa  
Dubai, United Arab Emirates  
Tel: +971 4811 8100

## Natural Gas Technologies

### Emerson Process Management Regulator Technologies, Inc.

USA - Headquarters  
McKinney, Texas 75069-1872 USA  
Tel: 1-800-558-5853  
Outside U.S. 1-972-548-3574

Asia-Pacific  
Singapore, Singapore 128461  
Tel: +65 6777 8211

Europe  
Bologna, Italy 40013  
Tel: +39 051 4190611  
Gallardon, France 28320  
Tel: +33 (0)2 37 33 47 00

## TESCOM

### Emerson Process Management Tescom Corporation

USA - Headquarters  
Elk River, Minnesota 55330-2445 USA  
Tel: 1-763-241-3238

Europe  
Selmsdorf, Germany 23923  
Tel: +49 (0) 38823 31 0

For further information visit [www.fisherregulators.com](http://www.fisherregulators.com)

The Emerson logo is a trademark and service mark of Emerson Electric Co. All other marks are the property of their prospective owners. Fisher is a mark owned by Fisher Controls, Inc., a business of Emerson Process Management.

The contents of this publication are presented for informational purposes only, and while every effort has been made to ensure their accuracy, they are not to be construed as warranties or guarantees, express or implied, regarding the products or services described herein or their use or applicability. We reserve the right to modify or improve the designs or specifications of such products at any time without notice.

Emerson Process Management does not assume responsibility for the selection, use or maintenance of any product. Responsibility for proper selection, use and maintenance of any Emerson Process Management product remains solely with the purchaser.