

Fisher™ C1 Pneumatic Controllers and Transmitters

Contents

Introduction	2
Scope of Manual	2
Description	2
Specifications	2
Educational Services	2
Installation	6
Standard Installation	6
Panel Mounting	7
Wall Mounting	7
Pipestand Mounting	7
Actuator Mounting	7
Pressure Connections	9
Supply Pressure	9
Process Pressure	10
Vent Assembly	11
Controller Operation	11
Proportional-Only Controllers	11
Adjustments	11
Adjustment: Set Point	11
Adjustment: Proportional Band	11
Calibration: Proportional-Only Controllers	12
Startup: Proportional-Only Controllers	15
Proportional-Plus-Reset Controller	15
Adjustments	16
Adjustment: Set Point	16
Adjustment: Proportional Band	16
Adjustment: Reset	16
Adjustment: Anti-Reset Windup	17
Calibration	17
Calibration: Proportional-Plus-Reset Controllers	17
Calibration: Anti-Reset Windup	19
Startup: Proportional-Plus-Reset Controllers	20
Differential Gap Controllers	20
Adjustments	21
Adjustment: Set Point	21
Adjustment: Proportional Band	21
Calibration: Differential Gap Controllers	21
Startup: Differential Gap Controllers	23
Transmitter Operation	23
Adjustments	23
Adjustment: Zero	23
Adjustment: Span	24

Figure 1. Fisher C1 Controller Yoke-Mounted on Control Valve Actuator



Calibration: Transmitters	24
Startup: Transmitters	26
Principle of Operation	27
Proportional-Only Controllers	27
Proportional-Plus-Reset Controllers	28
Controllers with Anti-Reset Windup	28
Differential Gap Controllers	28
Transmitters	29
Maintenance	30
Replacing Gauges	30
Replacing Bourdon Tube	31
Replacing Bellows Sensing Element	32
Changing Proportional or Reset Valve	33
Changing Anti-Reset Windup Differential Relief Valve	33
Changing Action	33
Proportional-Only to a Differential Gap Controller	33
Reverse to Direct Action	34
Relay Replacement	36
Changing Output Signal Range	37
Parts Ordering	40

Contents (Continued)

Parts Kits	41
Parts List	41
Common Parts	41
Mounting Parts for Panel, Wall, Pipestand or Actuator Mounting	50

Introduction

Scope of Manual

This instruction manual provides installation, operating, maintenance, and parts information for the Fisher C1 pressure controllers and transmitters shown in figure 1. Refer to separate instruction manuals for information regarding the control valve, actuator, and accessories.



Do not install, operate, or maintain C1 pressure controllers and transmitters without first being fully trained and qualified in valve, actuator, and accessory installation, operation, and maintenance. To avoid personal injury and property damage, it is important to carefully read, understand, and follow all the contents of this manual, including all safety cautions and warnings. If you have any questions about these instructions, contact your [Emerson sales office](#) before proceeding.

Description

The C1 pneumatic pressure controllers and transmitters use a bellows or Bourdon tube sensing element to sense the gauge pressure, vacuum, compound pressure, or differential pressure of a liquid or gas. The controller or transmitter output is a pneumatic pressure signal that can be used to operate a final control element, indicating device, or recording device.

Unless otherwise noted, all NACE references are to NACE MR0175 / ISO15156 & NACE MR0103.

Specifications

Specifications for the C1 controllers and transmitters are listed in table 1. Table 2 explains available configurations and options.

Educational Services

Emerson Automation Solutions
 Educational Services - Registration
 Phone: +1-800-338-8158
 e-mail: education@emerson.com
www.emerson.com/mytraining

Table 1. Specifications

<p>Available Configurations See table 2</p> <p>Input Signal Type: ■ Gauge pressure, ■ vacuum, ■ compound pressure, or ■ differential pressure of a liquid or gas Limits: See table 3 or 4</p> <p>Output Signal Proportional-Only or Proportional-Plus-Reset Controllers and Transmitters: ■ 0.2 to 1.0 bar (3 to 15 psig) or ■ 0.4 to 2.0 bar (6 to 30 psig) pneumatic pressure signal Differential Gap Controllers: ■ 0 and 1.4 bar (0 and 20 psig) or ■ 0 and 2.4 bar (0 and 35 psig) pneumatic pressure signal Action: Control action is field reversible between ■ direct (increasing sensed pressure produces increasing output signal) and ■ reverse (increasing sensed pressure produces decreasing output signal).</p> <p>Supply Pressure Requirements⁽¹⁾ See table 5</p> <p>Supply Pressure Medium Air or Natural Gas Supply medium must be clean, dry and non-corrosive Per ISA Standard 7.0.01 A maximum 40 micrometer particle size in the air system is acceptable. Further filtration down to 5 micrometer particle size is recommended. Lubricant content is not to exceed 1 ppm weight (w/w) or volume (v/v) basis. Condensation in the air supply should be minimized Per ISO 8573-1 <i>Maximum particle density size: Class 7</i> <i>Oil content: Class 3</i> <i>Pressure Dew Point: Class 3 or at least 10°C less than the lowest ambient temperature expected</i></p> <p>Steady-State Air Consumption⁽²⁾⁽³⁾ 0.2 to 1.0 bar (3 to 15 psig): 0.08 normal m³/hour (3 scfh) 0.4 to 2.0 bar (6 to 30 psig): 0.12 normal m³/hour (4.5 scfh)</p>	<p>Supply and Output Connections 1/4 NPT internal</p> <p>Common Signal Pressure Conversions See table 6</p> <p>Proportional Band Adjustment For Proportional-Only Controllers: Full output pressure change adjustable from ■ 2% to 100% of the sensing element range for 0.2 to 1.0 bar (3 to 15 psig) or ■ 4% to 100% of the sensing element range for 0.4 to 2.0 bar (6 to 30 psig) For Proportional-Plus-Reset Controllers: Full output pressure change adjustable from ■ 3% to 100% of the sensing element range for 0.2 to 1.0 bar (3 to 15 psig), or ■ 6% to 100% of the sensing element range for 0.4 to 2.0 bar (6 to 30 psig)</p> <p>Differential Gap Adjustment For Differential Gap Controllers: Full output pressure change adjustable from 15% to 100% of sensing element range</p> <p>Reset Adjustment For Proportional-Plus-Reset Controllers: Adjustable from 0.01 to 74 minutes per repeat (100 to 0.01 repeats per minute)</p> <p>Zero Adjustment (Transmitters Only) Continuously adjustable to position span of less than 100% anywhere within the sensing element range</p> <p>Span Adjustment (Transmitters Only) Full output pressure change adjustable from 6 to 100% of sensing element range</p> <p>Performance Repeatability: 0.5% of sensing element range Deadband (Except Differential Gap Controllers)⁽⁴⁾: 0.1% of sensing element range Typical Frequency Response at 100% Proportional Band <i>Output to Actuator:</i> 0.7 Hz and 110 degree phase shift with 1850 cm³ (113 inches³) volume, actuator at mid-stroke <i>Output to Positioner Bellows:</i> 9 Hz and 130 degree phase shift with 0.2 to 1.0 bar (3 to 15 psig) output to 33 cm³ (2 inches³) bellows</p>
---	---

-continued-

Table 1. Specifications (continued)

<p>Ambient Operating Temperature Limits⁽¹⁾</p> <ul style="list-style-type: none"> ■ Standard Construction: -40 to 71 °C (-40 to 160 °F) ■ High Temperature Construction: -18 to 104 °C (0 to 220 °F) <p>Anti-reset windup (differential pressure relief) and process pressure gauge options are only available in the standard construction</p> <p>If the process temperature is outside the ambient operating range of the controller, the length of the capillary tube run from the sensor point to the controller process input may be adjusted to protect the controller from the process temperature</p> <p>Typical Ambient Temperature Operating Influence</p> <p>Proportional Control only: ± 3.0% of output span for each 28 °C (50 °F) change in temperature between -40 and 71 °C (-40 and 160 °F) for a controller set at 100% proportional band</p> <p>Proportional-Plus-Reset Control: ± 2.0% of output span for each 28 °C (50 °F) change in temperature between -40 and 71 °C (-40 and 160 °F) for a controller set at 100% proportional band</p> <p>Transmitters only: ± 3.0% of output span for each 28 °C (50 °F) change in temperature between -40 and 71 °C (-40 and 160 °F) for a transmitter set at 100% span</p>	<p>Hazardous Area Classification</p> <p>Complies with the requirements of ATEX Group II Category 2 Gas and Dust</p> <p></p> <p>Maximum surface temperature (Tx) depends on operating conditions</p> <p>Gas: T4, T5, T6 Dust: T85...T104</p> <p>Refer to figure 26 for location of ATEX marking</p> <p>Approximate Weight</p> <p>8.2 kg (18 pounds)</p> <p>Declaration of SEP</p> <p>Fisher Controls International LLC declares this product to be in compliance with Article 4 paragraph 3 PED Directive 2014/68/EU. It was designed and manufactured in accordance with Sound Engineering Practice (SEP) and cannot bear the CE marking related to PED compliance.</p> <p>However, the product <i>may</i> bear the CE marking to indicate compliance with <i>other</i> applicable European Community Directives.</p>
---	--

1. The pressure/temperature limits in this document and any applicable standard or code limitation should not be exceeded.
 2. Normal m³/hr: normal cubic meters per hour (m³/hr, 0 °C and 1.01325 bar, absolute). Scfh: standard cubic feet per hour (ft³/hr, 60 °F and 14.7 psig).
 3. To convert from air flow rate to natural gas flow rate multiply by 1.29.
 4. An adjustable differential gap (differential gap controllers) is equivalent to an adjustable deadband.

Table 2. Available Configurations

DESCRIPTION	TYPE NUMBER			
	Bourdon Tube Sensing Element (Gauge Pressure Only)	Bellows Sensing Element		
		Gauge Pressure	Differential Pressure	
Proportional-only controller	C1P	C1B	C1D	
Proportional-plus-reset controller			Without anti-reset windup	---
			With anti-reset windup	---
Differential gap controller				
Transmitter			C1D	

Table 3. Bourdon Tube Pressure Range and Materials

PRESSURE RANGES ^(1,2)		MAXIMUM ALLOWABLE STATIC PRESSURE LIMITS ⁽³⁾				MATERIAL ⁽⁵⁾
		Standard		With Optional Travel Stop ⁽⁴⁾		
Bar	Psig	Bar	Psig	Bar	Psig	
0 to 2.0	0 to 30	2.0	30	3.3	48	316 stainless steel
0 to 4.0	0 to 60	4.0	60	6.6	96	
0 to 7.0	0 to 100	7.0	100	11	160	
0 to 14	0 to 200	14	200	19	280	
0 to 20	0 to 300	20	300	29	420	
0 to 40	0 to 600	40	600	50	720	
0 to 70	0 to 1000	70	1000	83	1200	
0 to 100	0 to 1500	100	1500	115	1650	
0 to 200	0 to 3000	200	3000	230	3300	
0 to 350	0 to 5000	350	5000	380	5500	
0 to 550	0 to 8000	550	8000	550	8000	
0 to 700	0 to 10,000	700	10,000	700	10,000	

1. If the process can trip to a pressure outside of the operating range of the sensing element, a commercially available device, such as an overpressure protector, may be used to protect against pressure surges and pulsations.
 2. Range marked on Bourdon tube may be in kPa (1 bar = 100 kPa)
 3. Bourdon tube may be pressurized to limit shown without permanent zero shift.
 4. With travel stop set at 110% of the range.
 5. Bourdon tubes are also available in NACE compliant material. Contact your [Emerson sales office](#) for additional information.

Table 4. Bellows Pressure Ranges and Materials

PRESSURE RANGES ⁽¹⁾			MAXIMUM ALLOWABLE STATIC PRESSURE LIMITS ⁽²⁾			
			Brass Construction		Stainless Steel Construction	
			Bar	Psig	Bar	Psig
Gauge Pressure	Vacuum	0 to 150 mbar (0 to 60 inch wc)	1.4	20	---	---
		0 to 340 mbar (0 to 10 inch Hg)	2.8	40	---	---
		0 to 1.0 bar (0 to 30 inch Hg)	2.8	40	6.9	100
	Compound Pressure	75 mbar vac. to 75 mbar (30 inch wc vac. to 30 inch wc)	1.4	20	---	---
		500 mbar vac. to 500 mbar (15 inch Hg vac. to 7.5 psig)	2.8	40	6.9	100
		1.0 bar vac. to 1.0 bar (30 inch Hg vac. to 15 psig)	2.8	40	6.9	100
	Positive pressure	0 to 150 mbar (0 to 60 inch wc)	1.4	20	---	---
		0 to 250 mbar ⁽³⁾ (0 to 100 inch wc)	1.4	20	---	---
		0 to 350 mbar ⁽⁴⁾ (0 to 140 inch wc)	2.8	40	---	---
		0 to 0.35 bar (0 to 5 psig)	2.8	40	---	---
		0 to 0.5 bar (0 to 7.5 psig)	2.8	40	---	---
		0 to 0.7 bar (0 to 10 psig)	2.8	40	---	---
Differential Pressure ⁽⁵⁾	0 to 0.7 bar (0 to 10 psi)	2.8	40	---	---	
	0 to 1.4 bar (0 to 20 psi)	2.8	40	---	---	
	0 to 2.0 bar (0 to 30 psi)	2.8	40	---	---	
	0 to 300 mbar (0 to 80 inch wc)	1.4	20	---	---	
	0 to 0.7 bar (0 to 10 psi)	2.8	40	---	---	
	0 to 1.4 bar (0 to 20 psi)	2.8	40	---	---	

1. If the process can trip to a pressure outside of the operating range of the sensing element, a commercially available device, such as an overpressure protector, may be used to protect against pressure surges and pulsations.
 2. Bellows may be pressurized to limit shown without permanent zero shift.
 3. Transmitter only.
 4. Except transmitter.
 5. The overrange limit for these sensing elements is a differential pressure equal to the maximum allowable static pressure limit.

Table 5. Supply Pressure Requirements

Output Signal Range		Normal Operating Supply Pressure ⁽¹⁾	Maximum Allowable Supply Pressure To Prevent Internal Part Damage
Bar	0.2 to 1.0 or 0 and 1.4 (differential gap)	1.4	2.8
	0.4 to 2.0 or 0 and 2.4 (differential gap)	2.4	2.8
Psig	3 to 15 or 0 and 20 (differential gap)	20	40
	6 to 30 or 0 and 35 (differential gap)	35	40

1. If this pressure is exceeded, control may be impaired.

Table 6. Common Signal Pressure Conversions

Mps	kg/cm ²	bar	kPa	Psi
0.02	0.2	0.2 ⁽²⁾	20 ⁽¹⁾	3
0.03	0.3	0.3	35	5
0.04	0.4	0.4	40 ⁽¹⁾	6
0.05	0.5	0.5	50	7
0.06	0.6	0.6	60	9
0.07	0.8	0.8	75	11
0.08	0.8	0.8	80	12
0.09	1.0	1.0	95	14
0.10	1.0 ⁽³⁾	1.0 ⁽²⁾	100 ⁽¹⁾	15
0.12	1.3	1.2	125	18
0.14	1.4	1.4	140	20
0.15	1.5	1.5	150	22
0.17	1.8	1.7	170	25
0.18	1.9	1.9	185	27
0.20	2.0	2.0 ⁽³⁾	200 ⁽¹⁾	30
0.22	2.2	2.2	220	32
0.23	2.3	2.3	230	33
0.24	2.5	2.4	240	35
0.34	3.5	3.4	345	50
0.55	5.6	5.5	550	80
0.69	7.0	6.9	690	100
1.03	10.5	10.3	1035	150

1. Values as listed in ANSI/S7.4.
2. Values as listed in IEC Standard 382.
3. Values rounded to correspond with kPa values.

Installation

⚠ WARNING

To avoid personal injury or property damage resulting from the sudden release of pressure:

- Always wear protective clothing, gloves, and eyewear when performing any installation operations.
- Personal injury or property damage may result from fire or explosion if natural gas is used as the supply medium and appropriate preventive measures are not taken. Preventive measures may include, but are not limited to, one or more of the following; remote venting of the unit, re-evaluating the hazardous area classification, ensuring adequate ventilation, and the removal of any ignition sources. For information on remote venting of this controller/ transmitter, refer to page 11.
- If installing into an existing application, also refer to the WARNING at the beginning of the Maintenance section in this instruction manual.
- Check with your process or safety engineer for any additional measures that must be taken to protect against process media.

NOTICE

Do not use sealing tape on pneumatic connections. This instrument contains small passages that may become obstructed by detached sealing tape. Thread sealant paste should be used to seal and lubricate pneumatic threaded connections.

Standard Installation

The instruments are normally mounted vertical with the case/cover as shown in figure 1. If installing the instrument in any other position, be sure that the vent opening shown in figure 2 is facing downward.

Panel Mounting

Refer to figure 2.

Cut a hole in the panel surface according to the dimensions shown in figure 2. Remove the cap screws (key 252), brackets (key 251), and vent assembly (key 28). Slide the controller or transmitter into the cutout and reattach the brackets. Tighten the cap screw located in the center of each bracket to draw the case snugly and evenly against the panel. Reinstall the vent unless a remote vent will be used.

Wall Mounting

Refer to figure 2.

Drill four holes in the wall using the dimensions shown in figure 2. In the bracket (key 251) are 8.7 mm (0.3438 inch) diameter holes. Back out the cap screw located in the center of each bracket. (The screws are used for panel mounting but are not required for wall mounting.) If tubing runs through the wall, drill holes in the wall to accommodate the tubings. Figure 2 shows the pressure connection locations in the back of the case.

Mount the controller to the bracket using the four cap screws (key 252) provided. Attach the bracket to the wall, using suitable screws or bolts.

Pipestand Mounting

Refer to figure 2.

Use a hammer and punch to knock out the blanks in the two holes indicated in the back view of figure 2. Attach the spacer spools (key 228) and the mounting plate (key 213) to the controller with cap screws, lock washers, and nuts (keys 215, 221, and 216). Attach the controller to a 2-inch (nominal) pipe with pipe clamps (key 250).

Actuator Mounting

Refer to figure 3.

Controllers specified for mounting on a control valve actuator are mounted at the factory. If the instrument is ordered separately for installation on a control valve actuator, mount the instrument according to the following instructions.

Mounting parts for the different actuator types and sizes vary. Two typical actuator-mounting installations are shown in figure 3; see the parts list for parts required for the specific actuator type and size involved.

Use a hammer and punch to knock out the blanks in the two holes indicated in the back view of figure 2. Attach the spacer spools (key 228) and the mounting plate (key 213) to the controller with machine screws, lock washers, and nuts (keys 215, 221, and 216).

Attach the mounting bracket to the actuator yoke with cap screws (key 222) and, if needed, spacer spools. On some designs, the mounting bracket is attached to the actuator diaphragm casing rather than to the yoke.

Figure 2. Panel, Wall, and Pipestand Mounting

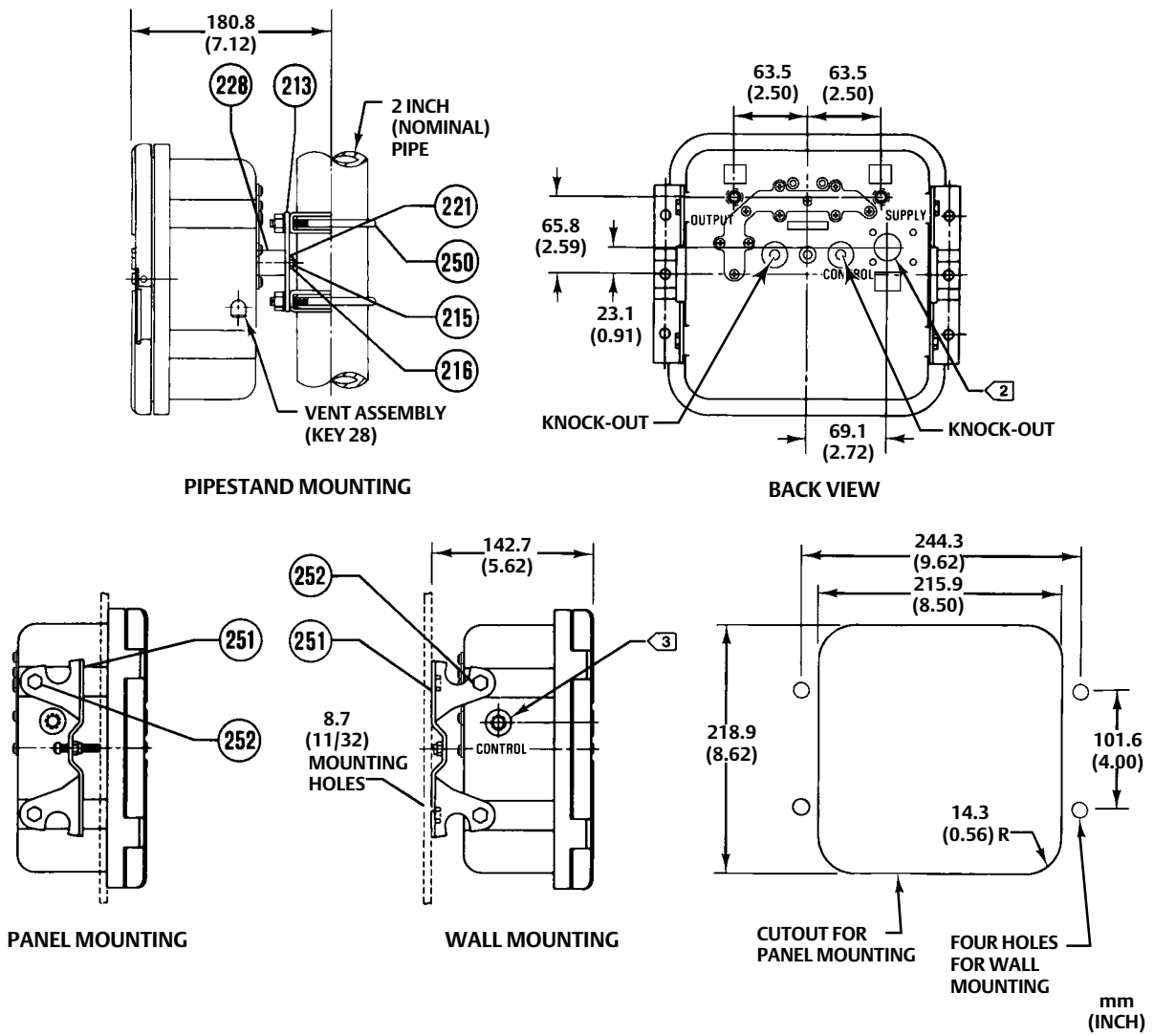

NOTES:

- 1. ALL CONNECTIONS ARE 1/4 NPT INTERNAL.
- 2 HIGH-PRESSURE CONNECTION FOR DIFFERENTIAL-PRESSURE UNITS.
- 3 LOW-PRESSURE CONNECTION FOR DIFFERENTIAL-PRESSURE UNITS.

E1052

Figure 3. Actuator Mounting

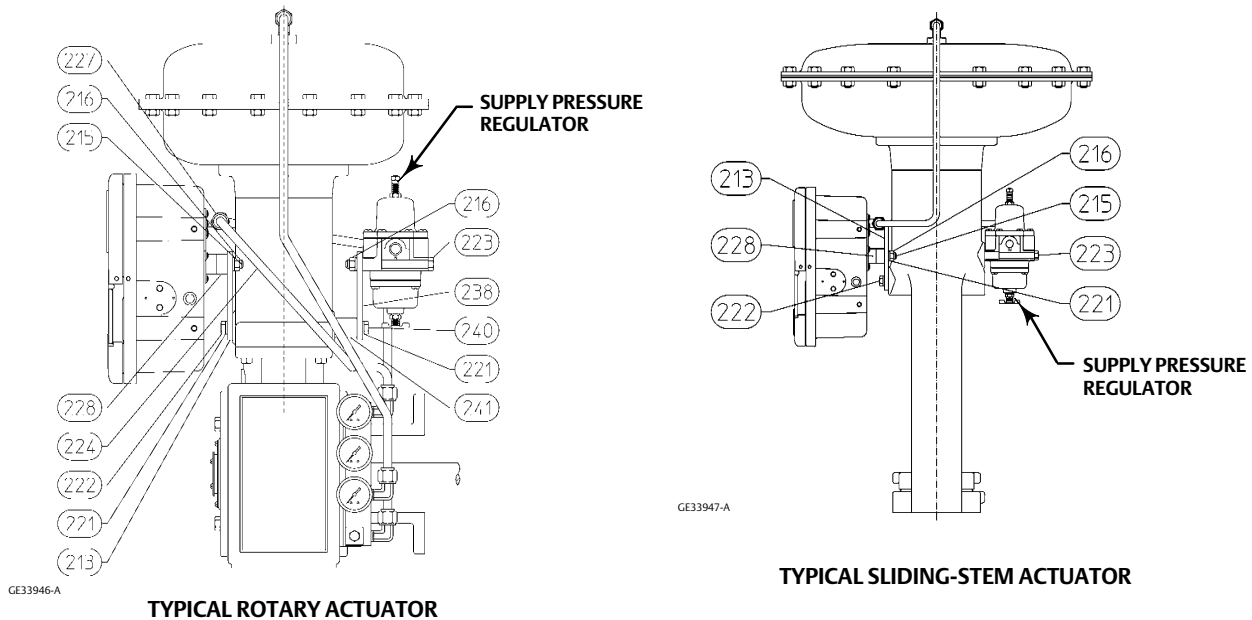

Pressure Connections

⚠ WARNING

To avoid personal injury or property damage resulting from the sudden release of pressure, do not install any system component where service conditions could exceed the limits given in this manual. Use pressure-relieving devices as required by government or accepted industry codes and good engineering practices.

NOTICE

Do not use sealing tape on pneumatic connections. This instrument contains small passages that may become obstructed by detached sealing tape. Thread sealant paste should be used to seal and lubricate pneumatic threaded connections.

All pressure connections on C1 instruments are 1/4 NPT internal. Use 6 mm (1/4-inch) or 10 mm (3/8-inch) pipe or tubing for supply and output piping. The pressure connection locations are shown in figure 2.

Supply Pressure

⚠ WARNING

Severe personal injury or property damage may occur from an uncontrolled process if the instrument supply medium is not clean, dry, oil-free and noncorrosive. While use and regular maintenance of a filter that removes particles larger than 40 micrometers in diameter will suffice in most applications, check with an Emerson field office and industry instrument supply medium quality standards for use with hazardous gas or if you are unsure about the proper amount or method of air filtration or filter maintenance.

Supply pressure medium must be clean, dry, and noncorrosive and meet the requirements of ISA Standard 7.0.01 or ISO 8573-1. A maximum 40 micrometer particle size in the air system is acceptable. Further filtration down to 5 micrometer particle size is recommended. Lubricant content is not to exceed 1 ppm weight (w/w) or volume (v/v) basis. Condensation in the supply medium should be minimized.

Use a suitable supply pressure regulator to reduce the supply pressure source to the normal operating supply pressure shown in table 5. Connect supply pressure to the SUPPLY connection at the back of the case.

⚠ WARNING

To avoid personal injury or property damage resulting from the sudden release of process pressure, use a high pressure regulator system when operating the controller or transmitter from a high pressure source.

If operating the controller or transmitter from a high pressure source [up to 138 bar (2000 psig)], use a high pressure regulator system, such as the Fisher 1367 High Pressure Instrument Supply System. For 1367 system installation, adjustment, and maintenance information, refer to the 1367 High-Pressure Instrument Supply System with Overpressure Protection instruction manual, [D100343X012](#).

Process Pressure

⚠ WARNING

To avoid personal injury or property damage resulting from the sudden release of pressure when using corrosive media, make sure the tubing and instrument components that contact the corrosive medium are of suitable noncorrosive material.

Also refer to the Installation Warning at the beginning of this section.

The pressure connections to the controller depend upon the type of pressure sensing, gauge or differential. Gauge pressure controllers use either a Bourdon tube or bellows as the sensing element, as indicated in table 2. Differential pressure controllers use two bellows to sense differential pressure.

For gauge pressure instruments: The control pressure block (key 10 in figure 22) has two connections. Process pressure can be connected either to the CONTROL connection on the back of the case, or to the connection on the left side of the case, shown in figure 2, depending on the instrument application. Plug the unused connection.

For differential pressure instruments: Connect the low pressure line to the CONTROL connection on the side of the case and the high pressure line to the CONTROL connection on the back of the case as shown in figure 2.

When installing process piping, follow accepted practices to ensure accurate transmission of the process pressure to the controller or transmitter. Install shutoff valves, vents, drains, or seal systems as needed in the process pressure lines. If the instrument is located such that the adjacent process pressure lines will be approximately horizontal, the lines should slope downward to the instrument for liquid-filled lines and upward to instruments for gas-filled lines. This will minimize the possibility of air becoming trapped in the sensor with liquid-filled lines or of condensation becoming trapped with gas-filled lines. The recommended slope is 83 mm per meter (1 inch per foot).

If a controller is being used in conjunction with a control valve to control pipeline pressure, connect the process pressure line in a straight section of pipe approximately 10 pipe diameters from the valve but away from bends, elbows, and areas of abnormal fluid velocities. For pressure-reducing service, the process line must be connected downstream of the valve. For pressure-relief service, the process pressure line must be connected upstream of the control valve. Install a needle valve in the process pressure line to dampen pulsations.

Vent Assembly

⚠ WARNING

Personal injury or property damage could result from fire or explosion of accumulated gas, or from contact with hazardous gas, if a flammable or hazardous gas is used as the supply pressure medium. Because the instrument case and cover assembly do not form a gas-tight seal when the assembly is enclosed, a remote vent line, adequate ventilation, and necessary safety measures should be used to prevent the accumulation of flammable or hazardous gas. However, a remote vent pipe alone cannot be relied upon to remove all flammable and hazardous gas. Vent line piping should comply with local and regional codes, and should be as short as possible with adequate inside diameter and few bends to reduce case pressure buildup.

NOTICE

When installing a remote vent pipe, take care not to overtighten the pipe in the vent connection. Excessive torque will damage the threads in the connection.

The vent assembly (key 28, figure 2) or the end of a remote vent pipe must be protected against the entrance of all foreign matter that could plug the vent. Use 13 mm (1/2-inch) pipe for the remote vent pipe, if one is required. Check the vent periodically to be certain it has not become plugged.

Controller Operation

Proportional-Only Controllers

This section describes the adjustments and procedures for calibration and startup. Adjustment locations are shown in figure 4 unless otherwise specified. All adjustments must be made with the cover open. When the adjustments and calibration procedures are complete, close and latch the cover.

To better understand the adjustments and overall operation of the controller, refer to the Principle of Operation section in this manual for proportional-only controllers. Refer also to the schematic diagram in figure 13.

Adjustments

Adjustment: Set Point

Adjust the pressure setting knob by turning the knob clockwise to increase the set point and counterclockwise to decrease the set point. Note that the dial setting and actual process pressure may vary significantly, especially with a wide proportional band setting.

Adjustment: Proportional Band

To adjust the proportional band, rotate the proportional band adjustment knob to the desired value.

The proportional band adjustment determines the amount of change in controlled pressure required to cause the control valve to stroke fully. It may be adjusted from 2 to 100 percent for 0.2 to 1.0 bar (3 to 15 psig) or 4 to 100 percent for 0.4 to 2.0 bar (6 to 30 psig) of the nominal sensing element pressure rating.

Calibration: Proportional-Only Controllers

Unless otherwise indicated, key number locations are shown in figure 4.

Provide a process pressure source capable of simulating the process pressure range of the controller. If an output pressure gauge is not provided, install a suitable pressure gauge for calibration purposes.

Figure 4. Proportional-Only Controller Adjustment Locations

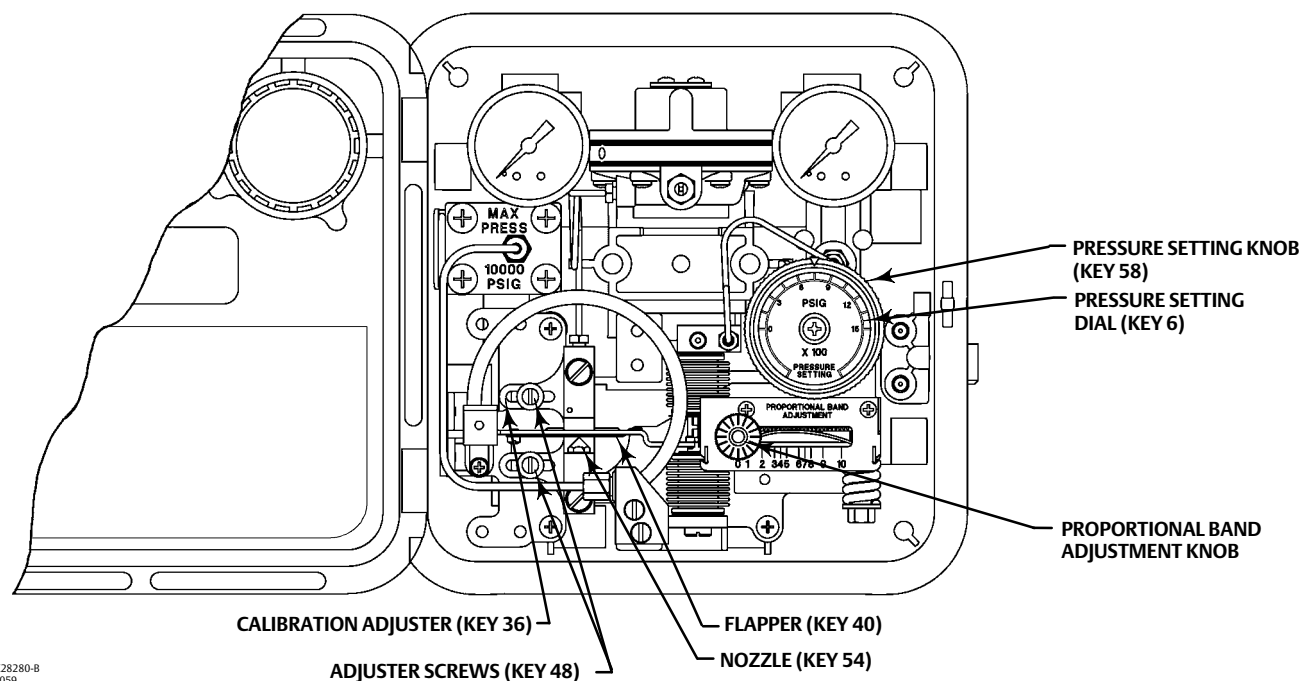

GE28280-B
E1059

Connect a pressure source to the supply pressure regulator and be sure the regulator is delivering the correct supply pressure to the controller. The controller must be connected open loop (Open loop: The controller output pressure changes must be dead ended into a pressure gauge). The following procedures use a 0.2 to 1.0 bar (3 to 15 psig) output pressure range as an example. For a 0.4 to 2.0 bar (6 to 30 psig) output range, adjust the values as appropriate.

1. Complete the above connections and provide a process pressure equal to the sensing element range.
2. Rotate the proportional band adjustment knob, shown in figure 4, to 1.5 (15 percent proportional band).
3. Verify that the calibration adjuster screws (key 48) are at mid-position in the calibration adjuster (key 36) slots.

Depending upon the controller action, perform one or the other of the following procedures.

For reverse-acting controllers:

4. Apply an input pressure equal to the sensing element upper range value.
5. Rotate the pressure setting knob to the maximum value.
6. Adjust the nozzle (key 54) until the controller output pressure is between 0.6 and 0.7 bar (8 and 10 psig).
7. Apply an input pressure equal to the sensing element lower range value.
8. Rotate the pressure setting knob to the minimum value.

Note

When performing the span adjustment in step 9, do not watch the output gauge while changing the calibration adjuster. The change in output is not a good indication of the change in span. While moving the calibration adjuster, the output pressure may change in the opposite direction than expected. For example, while moving the calibration adjuster to increase span, the output pressure may decrease. This should be disregarded since even though the output pressure decreases, the span is increasing.

Proper controller response depends on nozzle-to-flapper alignment.

When performing span adjustments, carefully loosen both calibration adjuster screws while holding the calibration adjuster in place. Then move the calibration adjuster slightly in the required direction by hand or using a screwdriver. Verify proper nozzle-to-flapper alignment and hold the calibration adjuster in place while tightening both adjustment screws.

9. If the output is not between 0.6 and 0.7 bar (8 and 10 psig), adjust the controller span by loosening the two adjusting screws (key 48) and moving the calibration adjuster (key 36) a small distance as indicated in figure 5.
10. Repeat steps 4 through 9 until no further adjustment is necessary.
11. Proceed to the startup procedure for proportional controllers.

Figure 5. Reverse-Acting Controller Span Adjustment – Proportional-Only Controllers

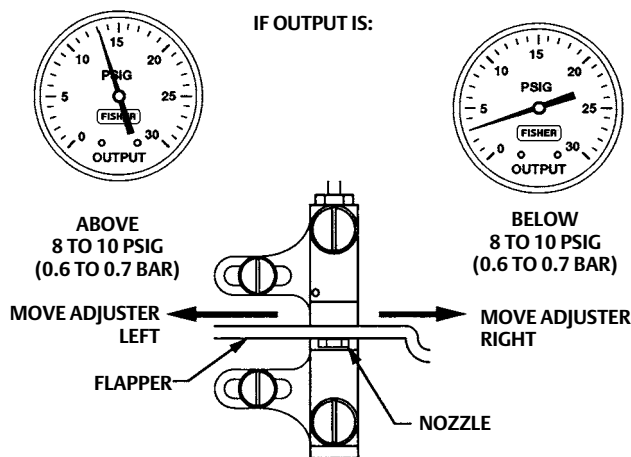

NOTE:
3 TO 15 PSIG (0.2 TO 1.0 BAR) OUTPUT SHOWN.
FOR 6 TO 30 PSIG (0.4 TO 2.0 BAR) OUTPUT, ADJUST
VALUES AS APPROPRIATE.

A6155-1

For direct-acting controllers:

4. Apply an input pressure equal to the sensing element lower range value.
5. Rotate the pressure setting knob to the minimum value.
6. Adjust the nozzle (key 54) until the controller output pressure is between 0.6 and 0.7 bar (8 and 10 psig.)
7. Apply an input pressure equal to the sensing element upper range value.
8. Rotate the pressure setting knob to the maximum value.

Note

When performing the span adjustment in step 9, do not watch the output gauge while changing the calibration adjuster. The change in output is not a good indication of the change in span. While moving the calibration adjuster, the output pressure may change in the opposite direction than expected. For example, while moving the calibration adjuster to increase span, the output pressure may decrease. This should be disregarded since even though the output pressure decreases, the span is increasing.

Proper controller response depends on nozzle-to-flapper alignment.

When performing span adjustments, carefully loosen both calibration adjuster screws while holding the calibration adjuster in place. Then move the calibration adjuster slightly in the required direction by hand or using a screwdriver. Verify proper nozzle-to-flapper alignment and hold the calibration adjuster in place while tightening both adjustment screws.

9. If the output is not between 0.6 and 0.7 bar (8 and 10 psig), adjust the controller span by loosening the two adjusting screws (key 48) and moving the calibration adjuster (key 36) a small distance as indicated in figure 6.
10. Repeat steps 4 through 9 until no further adjustment is necessary.
11. Proceed to the startup procedure for proportional controllers.

Figure 6. Direct-Acting Controller Span Adjustment—Proportional-Only Controllers

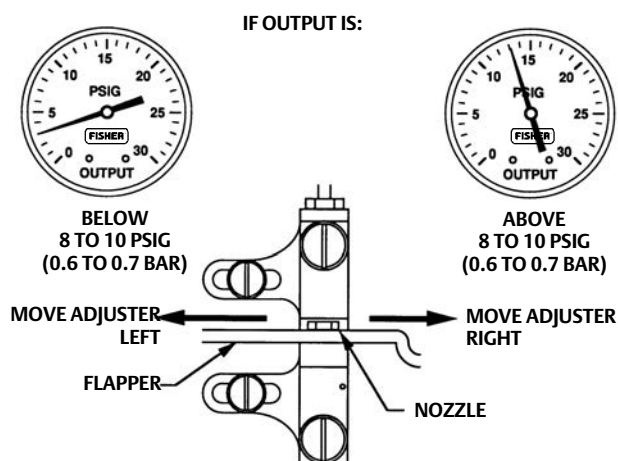

NOTE:
3 TO 15 PSIG (0.2 TO 1.0 BAR) OUTPUT SHOWN.
FOR 6 TO 30 PSIG (0.4 TO 2.0 BAR) OUTPUT, ADJUST
VALUES AS APPROPRIATE.

A6154

Startup: Proportional-Only Controllers (General Tuning Guidelines)

Calibrate the controller prior to this procedure.

1. Be sure that the supply pressure regulator is delivering the proper supply pressure to the controller.
2. Rotate the pressure setting knob to the desired set point.
3. Set the proportional band adjustment to 100 percent for fast processes (example: liquid pressure or liquid flow). For slow processes (example: temperature), calculate the percentage from the equation below:

For a slow process, determine the initial proportional band setting in percent from the following equation:

$$\frac{2 \times \text{Allowable Overshoot}}{\text{Pressure Span}} \times 100\% = \text{P.B.}$$

For example:

$$\frac{2 \times 0.14 \text{ bar}}{2.1 \text{ bar}} \times 100\% \cong 13\%$$

$$\left(\frac{2 \times 2 \text{ psig}}{30 \text{ psig}} \times 100\% \cong 13\% \right)$$

1.3 proportional band setting

4. Proportional Action

Disturb the system by tapping the flapper lightly or change the set point a small amount and check for system cycling. If the system does not cycle then lower the proportional band (raising the gain) and disturb the system again. Continue this procedure until the system cycles. At that point, double the proportional band setting.

Note

Proportional band adjustment affects the set point. Proportional-only controllers will show some offset from set point depending upon proportional band setting and process demand. After adjusting the proportional band, re-zero by carefully rotating the nozzle (key 54) until the steady-state process pressure equals the pressure setting dial reading.

This tuning procedure may be too conservative for some systems. The recommended proportional band setting should be checked for stability by introducing a disturbance and monitoring the process.

Proportional-Plus-Reset Controllers

This section describes the adjustments and procedures for calibration and startup. The adjustment locations are shown in figure 7 unless otherwise specified. All adjustments must be made with the cover open. When the adjustments and calibration procedures are complete, close and latch the cover. To better understand the adjustments and overall operation of the controller, refer to the Principle of Operation section in this manual for proportional-plus-reset controllers. Refer also to the schematic diagram in figure 13.

Figure 7. Proportional-Plus-Reset Controller Adjustment Locations

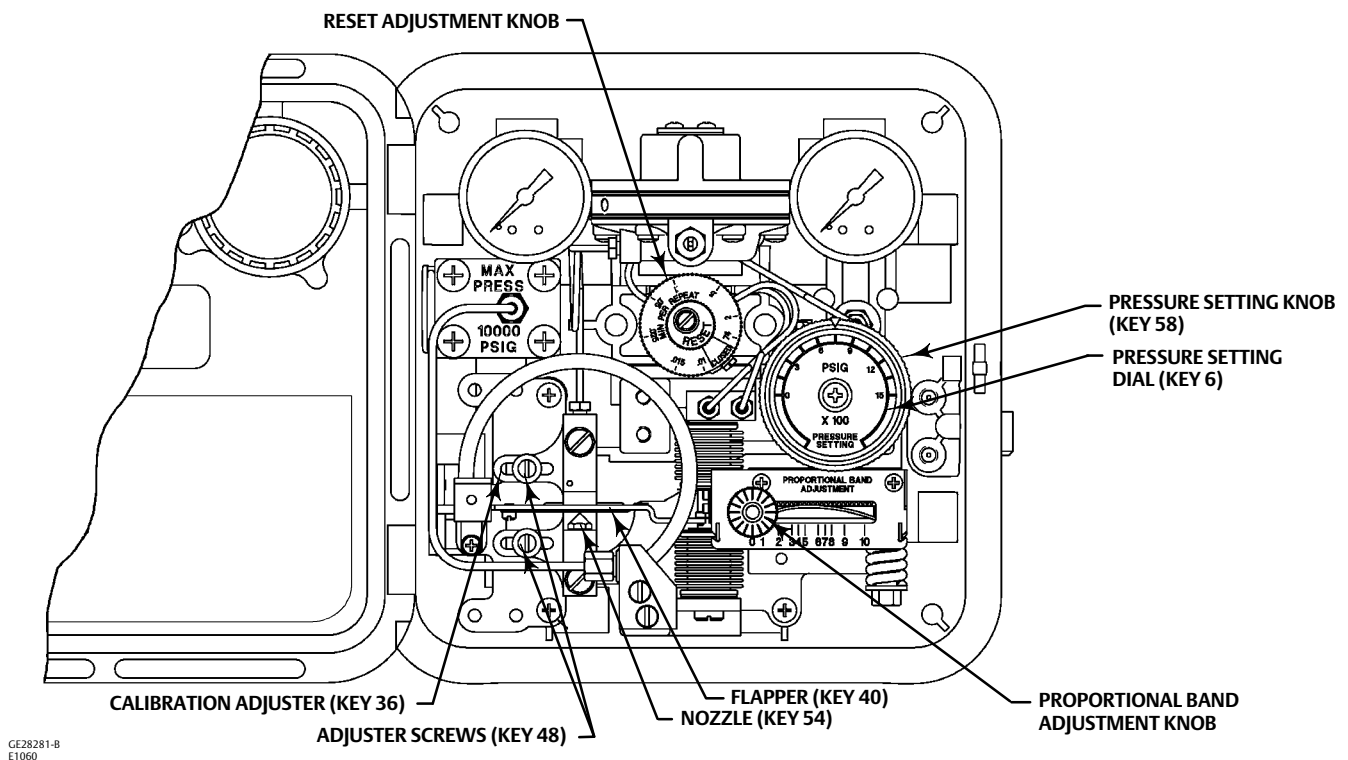
GE28281-B
E1060

Adjustments

Adjustment: Set Point

Adjust the pressure setting knob by turning the knob clockwise to increase the set point and counterclockwise to decrease the set point.

Rotate the knob until the indicator points to the desired set point pressure value. The pressure setting dial will reflect the desired set point if the controller is accurately calibrated.

Adjustment: Proportional Band

To adjust the proportional band, rotate the proportional band adjustment knob to the desired value.

The proportional band adjustment determines the amount of change in controlled pressure required to cause the control valve to stroke fully. It may be adjusted from 3 to 100 percent for 0.2 to 1.0 bar (3 to 15 psig) or 6 to 100 percent for 0.4 to 2.0 bar (6 to 30 psig) of the nominal sensing element pressure rating.

Adjustment: Reset

To adjust reset action turn the knob clockwise to decrease the minutes per repeat. Turn the knob counterclockwise to increase the minutes per repeat. Increasing the minutes per repeat provides a slower reset action.

The reset adjustment dial is calibrated in minutes per repeat. By definition, this is the time in minutes required for the reset action to produce an output change which is equal to the change produced by proportional control action. This is

in effect, the time in minutes required for the controller to increase (or decrease) its output pressure by an amount equal to a proportional increase (or decrease) caused by a change in set point or process pressure.

Adjustment: Anti-Reset Windup

The externally mounted differential relief valve can be mounted to relieve on increasing or decreasing output pressure.

Calibration

Calibration: Proportional-Plus-Reset Controllers

Unless otherwise indicated, key number locations are shown in figure 7.

Before starting this procedure:

- Provide a process pressure source capable of simulating the process pressure range of the controller.
- If an output pressure gauge is not provided, install a suitable pressure gauge for calibration purposes. The controller must be connected open loop (Open loop: The controller output pressure changes must be dead ended into a pressure gauge).

Note

C1P and C1B controllers with anti-reset windup are supplied with two O-rings (key 81), an anti-reset windup cover (key 80), and two machine screws (key 82). Use these parts in the next step.

1. For C1P and C1B controllers with anti-reset windup record the direction of the arrow on the anti-reset windup assembly (key 190, in figure 23). Remove the assembly and install the two O-rings (key 81), and cover (key 80) supplied with the controller. Secure the cover with the two machine screws (key 82) provided.
2. Connect regulated supply pressure to the controller. Do not exceed the normal operating pressure in table 5.
3. Rotate the reset knob to 0.01 minutes per repeat (fastest setting).
4. Rotate the proportional band adjustment knob to 1.5 (15 percent proportional band).
5. Verify that the calibration adjuster screws (key 48) are at mid-position in the calibration adjuster (key 36) slots.

Depending upon the controller action, perform one or the other of the following procedures.

For reverse-acting controllers:

6. Apply an input pressure equal to the sensing element upper range value.
7. Rotate the pressure setting knob to the maximum value.
8. Adjust the nozzle (key 54) until the controller output pressure is between 0.6 and 0.7 bar (8 and 10 psig).
9. Apply an input pressure equal to the sensing element lower range value.
10. Rotate the pressure setting knob to the minimum value.

Note

When performing the span adjustment in step 11, do not watch the output gauge while changing the calibration adjuster. The change in output is not a good indication of the change in span. While moving the calibration adjuster, the output pressure may

change in the opposite direction than expected. For example, while moving the calibration adjuster to increase span, the output pressure may decrease. This should be disregarded since even though the output pressure decreases, the span is increasing.

Proper controller response depends on nozzle-to-flapper alignment.

When performing span adjustments, carefully loosen both calibration adjuster screws while holding the calibration adjuster in place. Then move the calibration adjuster slightly in the required direction by hand or using a screwdriver. Verify proper nozzle-to-flapper alignment and hold the calibration adjuster in place while tightening both adjustment screws.

11. If the output pressure is not between 0.6 and 0.7 bar (8 and 10 psig), adjust the controller span by loosening the two adjusting screws (key 48) and moving the calibration adjuster (key 36) a small distance as indicated in figure 8.
12. Repeat steps 6 through 11 until no further adjustment is necessary.
13. For C1P and C1B controllers with anti-reset windup, remove the two machine screws, anti-reset windup cover, and two O-rings installed in step 1 of this procedure. Install the anti-reset windup assembly (key 190) with the arrow pointing in the direction recorded in step 1.
14. Proceed to the Startup procedures for proportional-plus-reset controllers.

Figure 8. Reverse-Acting Controller Span Adjustment—Proportional-Plus-Reset Controllers

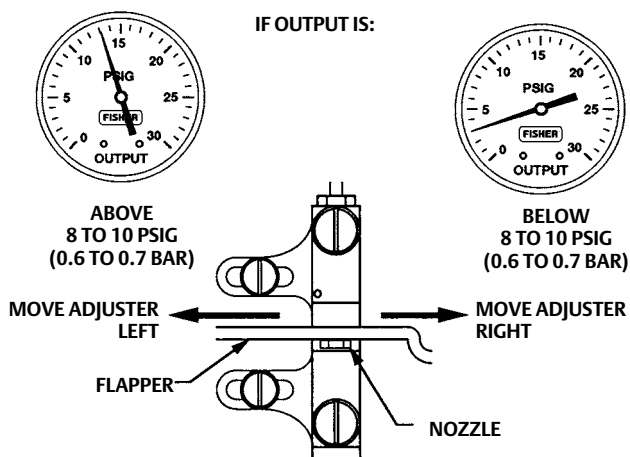

NOTE:
3 TO 15 PSIG (0.2 TO 1.0 BAR) OUTPUT SHOWN.
FOR 6 TO 30 PSIG (0.4 TO 2.0 BAR) OUTPUT, ADJUST
VALUES AS APPROPRIATE.

A6155-1

For direct-acting controllers:

6. Apply an input pressure equal to the sensing element lower range value.
7. Rotate the pressure setting knob to the minimum value.
8. Adjust the nozzle (key 54) until the controller output pressure is between 0.6 and 0.7 bar (8 and 10 psig).
9. Apply an input pressure equal to the sensing element upper range value.
10. Rotate the pressure setting knob to the maximum value.

Note

When performing the span adjustment in step 11, do not watch the output gauge while changing the calibration adjuster. The change in output is not a good indication of the change in span. While moving the calibration adjuster, the output pressure may

change in the opposite direction than expected. For example, while moving the calibration adjuster to increase span, the output pressure may decrease. This should be disregarded since even though the output pressure decreases, the span is increasing.

Proper controller response depends on nozzle-to-flapper alignment.

When performing span adjustments, carefully loosen both calibration adjuster screws while holding the calibration adjuster in place. Then move the calibration adjuster slightly in the required direction by hand or using a screwdriver. Verify proper nozzle-to-flapper alignment and hold the calibration adjuster in place while tightening both adjustment screws.

11. If the output pressure is not between 0.6 and 0.7 bar (8 and 10 psig), adjust the controller span by loosening the two adjusting screws (key 48) and moving the calibration adjuster (key 36) a small distance as indicated in figure 9.
12. Repeat steps 6 through 11 until no further adjustment is necessary.
13. For C1P and C1B controllers with anti-reset windup remove the two machine screws, anti-reset windup cover, and two O-rings installed in step 1 of this procedure. Install the anti-reset windup assembly (key 190) with the arrow pointing in the direction recorded in step 1.
14. Proceed to the Startup procedures for proportional-plus-reset controllers.

Figure 9. Direct-Acting Controller Span Adjustment —Proportional-Plus-Reset Controllers

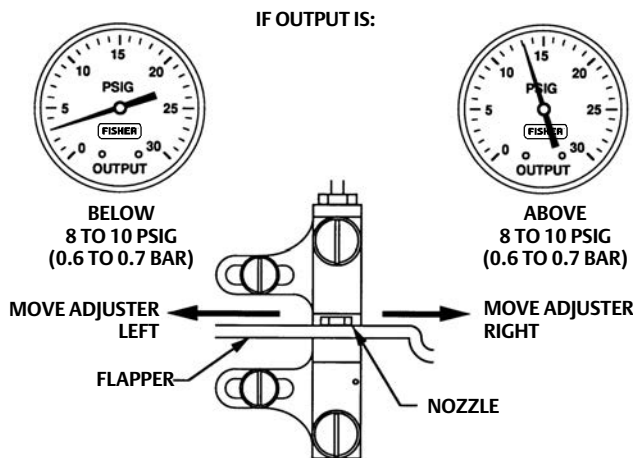

NOTE:
3 TO 15 PSIG (0.2 TO 1.0 BAR) OUTPUT SHOWN.
FOR 6 TO 30 PSIG (0.4 TO 2.0 BAR) OUTPUT, ADJUST
VALUES AS APPROPRIATE.
A6154

Calibration: Anti-Reset Windup

Controllers with anti-reset windup have a differential relief valve assembly (figure 23). This relief valve is set at the factory to relieve at a 0.3 bar (5 psi) pressure difference between the reset bellows pressure and the proportional bellows pressure. The valve can be adjusted to relieve from 0.14 to 0.4 bar (2 to 7 psig).

The relief valve can relieve on either rising controller output pressure or falling controller output pressure. If the arrow on the relief valve points toward the bottom of the controller case as shown in figure 23, the valve will relieve on falling output pressure. If the arrow points in the opposite direction, the valve will relieve on rising output pressure. The valve can be removed and reinstalled with the arrow pointing in the opposite direction to change the relief action.

Startup: Proportional-Plus-Reset Controllers (General Tuning Guidelines)

Calibrate the controller prior to this procedure.

1. Be sure that the supply pressure regulator is delivering the proper supply pressure to the controller.
2. Rotate the pressure setting knob to the desired set point.
3. Start with a reset setting of 0.05 minutes per repeat (m/r) for fast processes, and 0.5 m/r for slow processes.
4. Set the proportional band adjustment to 100 percent for fast processes (example: liquid pressure or liquid flow). For a slow process (example: temperature), calculate the percentage from the equation below:

For a slow process, determine the initial proportional band setting in percent from the following equation:

$$\frac{2 \times \text{Allowable Overshoot}}{\text{Pressure Span}} \times 100\% = \text{P.B.}$$

For example:

$$\frac{2 \times 0.14 \text{ bar}}{2.1 \text{ bar}} \times 100\% \cong 13\%$$

$$\left(\frac{2 \times 2 \text{ psig}}{30 \text{ psig}} \times 100\% \cong 13\% \right)$$

1.3 proportional band setting

5. Proportional Action:

Disturb the system by tapping the flapper lightly or change the set point a small amount and check for system cycling. If the system does not cycle then lower the proportional band (raising the gain) and disturb the system again. Continue this procedure until the system cycles. At that point, double the proportional band setting and begin tuning the reset.

6. Reset Action:

Disturb the system. If the system does not cycle then speed up the reset and disturb the system again. Continue this procedure until the system cycles. When the system cycles multiply the reset time setting by a factor of three (3) and slow the reset down to the new value. The reset is now tuned.

This tuning procedure may be too conservative for some systems. The recommended proportional band and reset setting should be checked for stability by introducing a disturbance and monitoring the process as previously described. For some applications, tighter control may be desirable.

Differential Gap Controllers

This section describes the adjustments and procedures for calibration and startup. The adjustment locations are shown in figure 4 unless otherwise specified. The output of each controller is checked at the factory before the instrument is shipped.

To convert a differential gap controller to a proportional-only controller or vice versa, refer to the appropriate procedure in the Maintenance section.

If the process pressure can be varied through all or part of the sensing element range or through the two desired switching points, use the process pressure for calibration. If not, provide a pressure source to simulate the process pressure range for calibration procedures.

To better understand the adjustments and overall operation of the controller, refer to the Principle of Operation section in this manual for differential gap controllers and the schematic diagram in figure 13.

Adjustments

Adjustment: Set Point

The position of the pressure setting knob determines the location of the differential gap within the range of the pressure sensing element. Move the pointer to the desired pressure where the output of the controller should switch from zero to full supply pressure with rising process pressure (direct-acting controllers) or with falling process pressure (reverse-acting controllers).

Adjustment: Proportional Band

The proportional band adjustment shown in figure 4 determines the width of the differential gap. The width of the gap is the difference between the process pressures at which the controller output will switch from zero to full supply pressure, or from full supply pressure to zero. The relationship between the proportional band dial setting and the differential gap is shown in figure 10.

Figure 10. Differential Gap Adjustment for Differential Gap Controllers

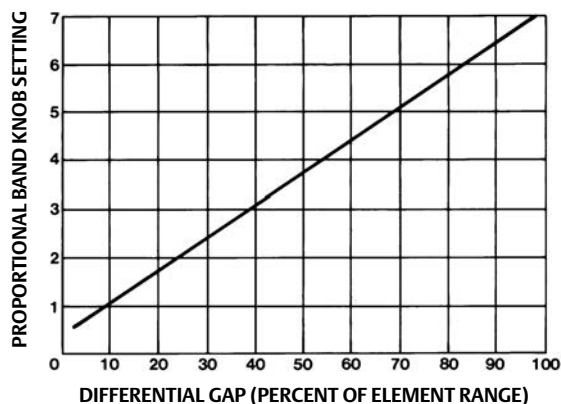

A2202-3

Calibration: Differential Gap Controllers

The output of each controller is checked at the factory before the unit is shipped. Before placing the controller in control of a process loop, check to verify that the controller is calibrated correctly for the application. The controller must be connected open loop (Open loop: The controller output pressure changes must be dead ended into a pressure gauge).

1. Temporarily convert the differential gap controller to proportional-only controller by disconnecting the proportional tubing (key 25, figure 16) from the mounting base. Reinstall the tubing into the other connection in the mounting base. Remove the proportional band assembly and invert it as shown in figure 16. Do not invert the reversing block (key 37, figure 16).
2. Temporarily invert the proportional band assembly (refer to figure 17):
 - a. Turn the proportional band assembly (key 73) to 10.
 - b. Unscrew the spring adjustor (key 65), removing the bias spring (key 70) and washers (key 62) with it.

- c. Unclip the lock spring (key 72). Remove the indicator scale (key 69) and proportional band adjustment knob (key 73).
 - d. Remove the gain adjustment bar (key 63). Flip it over so it attaches to the opposite side of the cantilever spring (key 8) as shown in figure 16 and screw it back down.
 - e. Flip over the indicator scale (key 69); install it and the proportional band adjustment knob (key 73) as a unit. Snap in the lock spring (key 72).
 - f. Tighten down the spring adjustor (key 65) with the bias spring (key 70) and washers (key 62) until it stops against the gain adjustment bar (key 63).
 - g. Turn the proportional band adjustment knob to the 10 setting. If it cannot be turned to the 10 setting, loosen the spring adjustor (key 65).
3. Calibrate using the calibration procedure for proportional-only controllers found on page 12 of this manual.
 4. When calibration is complete, return the tubing (key 25) and the proportional band assembly to their original locations and continue on with step 5 of this procedure.

Note

After reinstalling the tubing (key 25) and proportional band assembly a slight offset of the output pressure will be noticed due to a combination of switching from the proportional bellows to the reset bellows and the repositioning of the cantilever spring. Performing step 6b below adjusts for this offset.

5. Refer to figure 10 to determine the proportional band dial setting required for the desired differential gap.

For example, assume that a 0 to 100 psig sensing element is being used and the controller is to switch from zero to full supply pressure at a process pressure of 80 psig with rising process pressure and from full supply pressure to zero at 20 psig with falling pressure. (This is for a direct-acting controller.) The differential gap is:

$$\frac{5.5 \text{ bar} - 1.3 \text{ bar}}{6.9 \text{ bar}} \times 100\% = 60\%$$

$$\left(\frac{80 \text{ psig} - 20 \text{ psig}}{100 \text{ psig}} \times 100\% = 60\% \right)$$

From figure 10, the proportional band dial setting should be approximately 4.5; rotate the proportional band adjustment knob to 4.5.

6. Setting the process pressure

For a Direct-Acting Controller:

- a. Rotate the pressure setting knob to the pressure at which the controller output is to switch to the upper switching point (zero to full supply pressure) with rising process pressure. In the above example, this pressure is 5.5 bar (80 psig).
- b. Increase pressure to the sensing element while monitoring the output pressure gauge. The controller output pressure should switch from zero to full supply pressure when the upper switching point is reached with rising input pressure.

Note

If the upper switching point is not correct, adjust the nozzle to correct the error. Repeat step 6b until the input pressure and upper switching point are at the desired setting.

- c. With falling input pressure, the output should switch from full supply pressure back to zero when the lower switching point is reached.

Reverse-acting controllers produce the opposite response.

7. Vary the process pressure and observe the switching points. Widen or narrow the differential gap by rotating the proportional band adjustment knob, then repeat the above steps.

If the output is within the limits stated, refer to the startup procedures in this section. If the output pressure cannot be adjusted within the limits stated, refer to the maintenance procedures.

Startup: Differential Gap Controllers

Calibrate the controller prior to this procedure.

1. Be sure that the supply pressure regulator is delivering the proper supply pressure to the controller.
2. Adjust the proportional band setting for the proper differential gap (see figure 10).
3. If the controller is used in conjunction with a control valve, slowly open the upstream and downstream manual shutoff valves, and close the bypass valves.
4. To change the differential gap, perform steps 1 through 5 of the calibration for differential gap controllers procedure.

Transmitter Operation

This section describes the adjustments and procedures for calibration and startup. Refer to figure 11 for the adjustment locations. All adjustments must be made with the cover open. When the adjustments and calibration procedures are complete, close and latch the cover.

To better understand the adjustments and overall operation of the transmitter, refer to the Principle of Operation section in this manual for transmitters. Refer also to the schematic diagram in figure 13.

Adjustments

Adjustment: Zero

The pressure setting dial is marked ZERO ADJUSTMENT PRESSURE SETTING. Zero is in the center of the dial, and the pressure values increase to the right and left of the center as shown in figure 11. To set the zero, rotate the pointer around the pressure setting dial. Rotate the pointer clockwise to increase or counterclockwise to decrease the output depending on transmitter action and desired setting.

For direct-acting transmitters, zero adjustment determines the process pressure at which the transmitter output signal will be at its lower range limit.

The dial (key 6) graduations are approximate indications of the transmitter zero setting. When making adjustments, do not rely solely on the dial setting. Monitor the process pressure and output pressure to be sure the desired settings are attained.

Figure 11. Transmitter Adjustment Locations

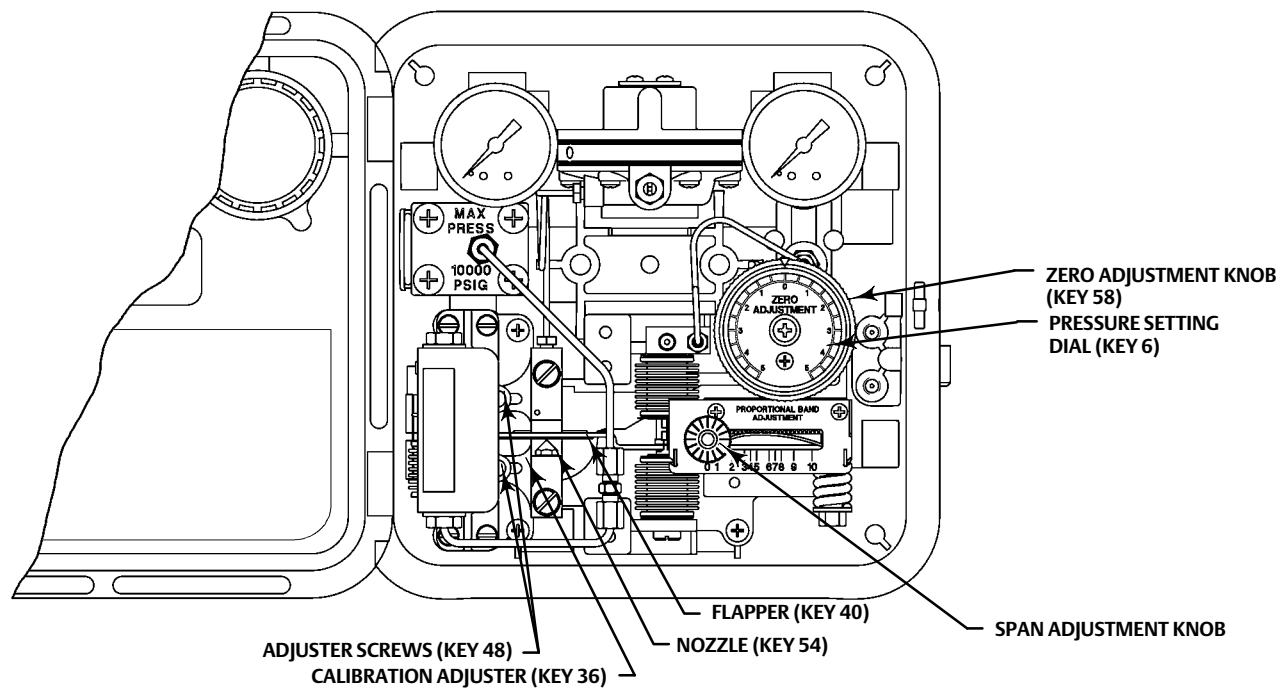
GE34729-B
E1061

Adjustment: Span

The span adjustment is graduated from 0 to 10. A setting of 10 represents a span setting of 100 percent of the process sensing element range. The transmitter achieves the highest accuracy when the span is 100 percent.

The transmitter span adjustment shown in figure 11 is the same as the controller proportional band adjustment.

Calibration: Transmitters

The output of each transmitter is checked at the factory before the unit is shipped. The transmitter provides an output signal that is proportional to the pressure applied to the sensing element. The output pressure has no direct effect on the process pressure.

The transmitter is calibrated at the factory and should not need additional adjustment. Use the following calibration procedures when the sensing element has been changed or other maintenance procedures have altered the calibration of the transmitter. The following procedures use a 0.2 to 1.0 bar (3 to 15 psig) output pressure range as an example. For other output pressure ranges [such as 0.4 to 2.0 bar (6 to 30 psig)] adjust the values to match the application.

Provide a process pressure source capable of simulating the process pressure range of the transmitter. If an output pressure gauge is not provided, install a suitable pressure gauge for calibration purposes. Connect a pressure source to the supply pressure regulator and be sure the regulator is delivering the correct supply pressure to the transmitter.

Note

For stability, some transmitter applications will require additional volume than just the gauge. Provide a minimum volume of approximately 25 cm³ (1.5 in³) or greater if stability is a problem.

Unless otherwise indicated, key number locations are shown in figure 11.

1. Complete the above connections and provide a process pressure equal to the sensing element range.
2. Rotate the span adjustment knob to the maximum setting on the dial (100 percent span).
3. Verify that the calibration adjuster screws (key 48) are at mid-position in the calibration adjuster (key 36) slots.

Depending upon the transmitter action, perform one or the other of the following procedures.

For reverse-acting transmitters:

4. Rotate the zero adjustment knob to zero.
5. Apply an input pressure equal to the sensing element upper range limit.
6. Adjust the nozzle (key 57) until the transmitter output pressure is at 0.2 bar (3 psig).
7. Set the input pressure equal to zero.

Note

Proper transmitter response depends on nozzle-to-flapper alignment.

When performing the span adjustment in step 8, carefully loosen both calibration adjuster screws while holding the calibration adjuster in place. Then move the calibration adjuster slightly in the required direction by hand or using a screwdriver. Verify proper nozzle-to-flapper alignment and hold the calibration adjuster in place while tightening both adjustment screws.

8. If the output pressure is not 15 psig, adjust the span by loosening the two adjusting screws (key 48) and moving the calibration adjuster (key 36) a small distance as indicated in figure 12.
9. Repeat steps 4 through 8 until no further adjustment is necessary.
10. Proceed to the startup procedure for transmitters.

Figure 12. Transmitter Span Adjustment

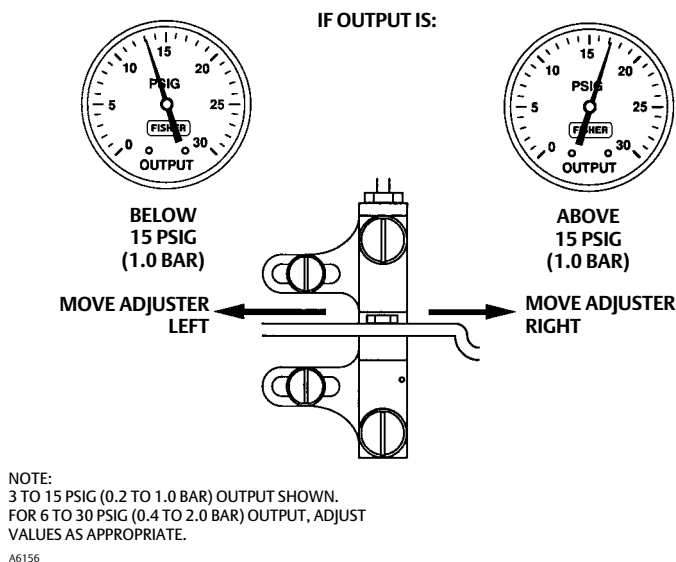

For direct-acting transmitters:

4. Rotate the zero adjustment knob to zero.
5. Set the input pressure to zero.
6. Adjust the nozzle (key 54) until the transmitter output pressure is at 0.2 bar (3 psig).
7. Apply an input pressure equal to the sensing element upper range value.

Note

Proper transmitter response depends on nozzle-to-flapper alignment.

When performing the span adjustment in step 8, carefully loosen both calibration adjuster screws while holding the calibration adjuster in place. Then move the calibration adjuster slightly in the required direction by hand or using a screwdriver. Verify proper nozzle-to-flapper alignment and hold the calibration adjuster in place while tightening both adjustment screws.

8. If the output pressure is not 15 psig, adjust the span by loosening the two adjusting screws (key 48) and moving the calibration adjuster (key 36) a small distance as indicated in figure 12.
9. Repeat steps 4 through 8 until no further adjustment is necessary.
10. Proceed to the startup procedure for transmitters.

Startup: Transmitters

1. Be sure that the supply pressure regulator is delivering the proper supply pressure to the transmitter.
2. Refer to the calibration procedures for the transmitter initial settings.
3. If the transmitter is used in conjunction with a control valve, slowly open the upstream and downstream manual shutoff valves, and close the bypass valves.

Principle of Operation

The following sections describe the operation of a controller or transmitter using a Bourdon tube sensing element. The operation is the same for an instrument using a bellows sensing element (key 71, figure 25) except that movement of the beam is caused by expansion or contraction of the bellows or differential bellows.

Proportional-Only Controllers

As shown in figure 13, supply pressure enters the relay and bleeds through the fixed orifice before escaping through the nozzle. Nozzle pressure also registers on the large relay diaphragm, and loading pressure (controller output pressure) registers on the small relay diaphragm.

Figure 13. Schematic of Reverse-Acting Proportional-Only and Proportional-Plus-Reset Controllers

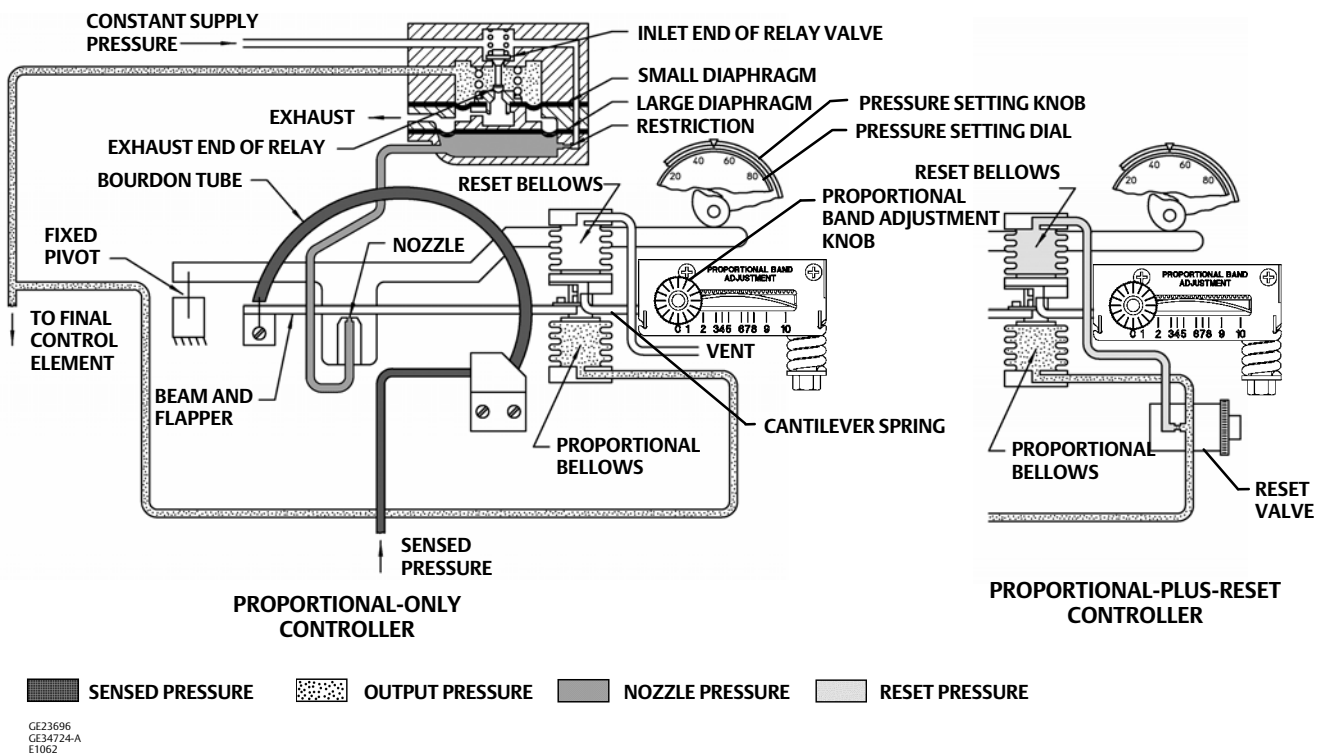

A change in the process pressure moves the beam and flapper with respect to the nozzle by either expanding or contracting the Bourdon tube arc. An increasing process pressure with direct action (or decreasing pressure with reverse action) produces a nozzle-flapper restriction that increases the loading on the large relay diaphragm and opens the relay valve. Additional supply pressure flows through the relay chamber to increase the loading pressure on the control valve actuator. A decreasing process pressure with direct action (or increasing pressure with reverse action) produces a nozzle-flapper opening that bleeds off pressure on the large relay diaphragm and opens the relay valve to exhaust controller output pressure from the actuator.

This controller output pressure change feeds back to the proportional bellows, countering the pressure change in the nozzle and equalizes the relay diaphragm pressure differential. The relay valve maintains a new loading pressure according to the change in sensed pressure.

If the proportional band adjustment is at its maximum setting (10), the cantilever spring in the proportional band assembly has a low spring rate, allowing more feedback motion to be transferred from the proportional bellows for a change in output pressure. As the effective length of the cantilever is reduced, its spring rate increases, causing less feedback motion from proportional bellows. Setting the cantilever spring to its maximum length results in a proportional band of 100%. The lower the proportional band adjustment, the shorter the effective length of the cantilever spring. The spring rate of the cantilever spring increases as its length shortens, allowing less motion to be transferred from the bellows to the beam and flapper for a given change in output pressure.

Proportional-Plus-Reset Controllers

Action of a proportional-plus-reset controller is similar to that of a proportional-only controller except that feedback from the controller output pressure is piped to a reset bellows as well as to the proportional bellows as shown at the right in figure 13.

With an increasing controller output pressure, pressure in the reset bellows increases. Increases in reset bellows pressure moves the beam and flapper closer to the nozzle, starting another increase of pressure throughout the system. Pressure buildup continues until the controlled pressure is brought back to the set point. The reset valve is adjustable to vary the amount of delay in the reset action. Closing the reset valve increases the delay in reset action.

Controllers with Anti-Reset Windup

During a prolonged difference between set point and the controlled variable, such as encountered with intermittent control applications (e.g., batch temperature control or wide open monitors on pressure control), reset ramps the controller output to either zero or full supply pressure; this condition is reset windup. When the controlled variable crosses the set point, there will be a delay before the controller output responds to the change in controlled variable. Anti-reset windup minimizes this delay and permits returning the controlled variable to set point more quickly with minimal overshoot.

As shown in figure 14 a proportional-plus-reset controller with anti-reset windup includes a differential relief valve. The valve consists of two pressure chambers separated by a spring-loaded diaphragm.

For the controller shown in figure 14, proportional pressure registers rapidly on the spring side of the relief valve diaphragm as well as in the proportional bellows, and reset pressure registers on the opposite side of the relief valve diaphragm. As long as controlled pressure changes are slow enough for normal proportional and reset action, the relief valve spring will keep the relief valve diaphragm from opening. However, a large or rapid decrease in controller pressure will cause the relay to exhaust loading pressure from the control device rapidly, and also from the proportional system and spring side of the relief diaphragm. If this decrease on the spring side of the diaphragm is greater than the relief valve spring setting, the diaphragm will move off the relief valve orifice and permit the proportional pressure on the opposite side of the relief valve diaphragm to bleed rapidly into the reset bellows. The anti-reset windup action also can be reversed to relieve with an increasing proportional pressure.

Differential Gap Controllers

With a differential gap controller, feedback pressure does not counteract the change in flapper position as it does in a proportional-only controller. Instead, feedback pressure is piped to the bellows located on the side of the beam and flapper opposite the nozzle (the proportional bellows in figure 13). Then, as controller output pressure increases, feedback pressure moves the flapper closer to the nozzle to again increase controller output pressure. This process continues rapidly until the controller output pressure is at the upper range limit. The action of a differential gap controller is so rapid that output pressure changes from zero to maximum as soon as the switching point is reached.

The action is similar with falling output pressure. Lower feedback pressure lowers the bellows pressure, which moves the flapper away from the nozzle. This again reduces the output pressure and continues until the output pressure is zero.

Figure 14. Schematic of Reverse-Acting Proportional-Plus-Reset Controller with Anti-Reset Windup

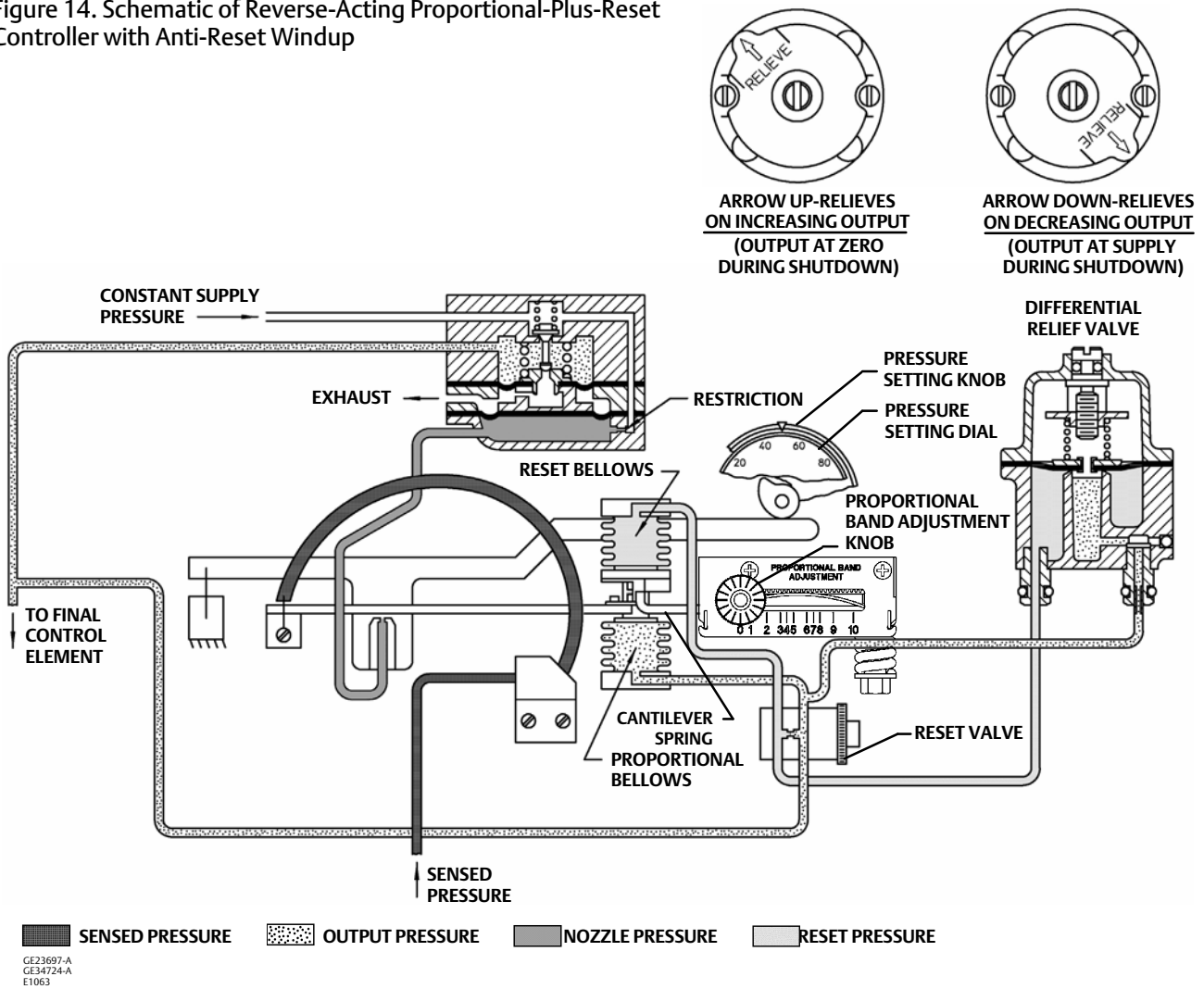

Transmitters

Action of a pneumatic transmitter is similar to that of a proportional-only controller. Since the output pressure of the transmitter has no effect on the process pressure, transmitter output pressure is a proportional measure of the process pressure. The proportional band adjustment determines the span of the transmitter, and the pressure setting mechanism determines the zero of the transmitter.

Maintenance

If the installation includes a Fisher 67 filter regulator, periodically open the drain on the filter regulator to drain accumulated moisture. Also, push the spring-out cleaning wire on the relay orifice. Check the opening of the vent assembly (key 28, figure 2) or the opening of the remote vent pipe, if one is used. If necessary, clean the openings.

Parts are subject to normal wear and must be inspected and replaced as necessary. The frequency of inspection and parts replacement depends upon the severity of the service conditions.

⚠ WARNING

The following maintenance procedures require taking the controller out of service. To avoid personal injury and property damage caused by the release of pressure or process fluid, observe the following before starting maintenance:

- Always wear protective clothing, gloves, and eyewear.
- Provide some temporary means of control for the process before taking the controller out of service.
- Provide a means of containing the process fluid before removing any measurement devices from the process.
- Use lock-out procedures to be sure that the above measures stay in effect while you work on the equipment.
- Personal injury or property damage may result from fire or explosion if natural gas is used as the supply medium and appropriate preventative measures are not taken. Preventative measures may include, but are not limited to, one or more of the following: Remote venting of the unit, re-evaluating the hazardous area classification, ensuring adequate ventilation, and the removal of any ignition sources. For information on remote venting of this controller/ transmitter, refer to page 11.
- Check with your process or safety engineer for any additional measures that must be taken to protect against process media.

Replacing Gauges

Refer to figures 22 and 23 for key number locations unless otherwise directed.

Three gauge configurations are available for C1 units.

- Output and supply pressure indications
- Output and process pressure indications
- Output, process, and supply pressure indications

One gauge type (key 2) is used for both output and supply pressure indications when the gauges are installed inside the controller case. Key 2 features a 1/8-inch connecting stem that matches the threaded gauge boss extending from the relay base.

In some cases, a process pressure gauge (key 4) covers the position of the internal supply pressure gauge. The supply pressure gauge has been removed and replaced with a pipe plug (key 15). The pressure control block (key 10) is different to accommodate a different tubing assembly (key 23) with a pressure connection (key 14) for a process pressure gauge. If a supply pressure gauge is required, a gauge with a 1/4-inch connecting stem (key 3) must be mounted on the supply pressure regulator.

NOTICE

Before performing this procedure, be sure the replacement gauges are the correct range so they are not damaged by overpressure.

Note

Key 2 is used as both a supply gauge and an output gauge on units without a process pressure gauge. A quantity of 2 is required for these units. On units with a process pressure indicator gauge (key 4), key 2 is used for the output gauge. A quantity of 1 is required for these units.

Use key 3 for supply pressure indication when a process pressure gauge is installed. Key 3 installs on the supply pressure regulator.

1. Shut off the supply pressure and process lines to the controller or transmitter.
2. Remove the gauge to be replaced:
 - Unscrew the output or supply gauge (key 2) from the relay base.
 - Unscrew the process pressure gauge (key 4) from the process connection (key 14).
 - Unscrew the supply gauge (key 3) from the supply pressure regulator.
3. Coat the threads of the replacement gauge with a sealant.
4. Screw the replacement gauge into the relay base, process connection, or supply pressure regulator.
5. Check for leaks by applying the correct supply pressure with the nozzle capped to produce full output pressure.

Replacing Bourdon Tube

Refer to figure 24 for key number locations unless otherwise directed.

1. Shut off the supply pressure and process lines to the controller or transmitter.
2. Unscrew the machine screw (key 56) to disconnect the link (key 16) and bearing (key 31) from the beam (key 39). Be careful to avoid losing the bearing (key 31). Washer(s) (key 62) for the machine screw (key 56) are at times furnished for insertion at the beam (key 39) connection to ensure alignment of the connecting link (key 16).
3. Disconnect the control tubing (key 23, figure 23). Unscrew the two screws (key 55) and washers (key 45), and remove the Bourdon tube (key 5).
4. Unscrew the machine screw (key 56), and remove the link and bearing (keys 16 and 31) from the Bourdon tube. Be careful to avoid losing the bearing.
5. Attach the link and bearing to the replacement Bourdon tube.
6. Attach the Bourdon tube with two machine screws and washers (keys 55 and 45).
7. Connect the link and bearing to the beam (key 39).
8. After connecting the link to the beam, make sure that the link is parallel to the sensing element (key 5) and the beam (key 39) so that it does not bind against the sensing element of the beam. Figure 15 shows a properly aligned connecting link; the connecting link is not in contact with the Bourdon tube or washers. When properly configured, the connecting link moves freely when touched. Washers (key 62) are used as shims to set parallelism.
9. Check to be sure that the beam is parallel with the bottom of the case and that the link (key 16) is in tension. If the beam is not parallel with the case, loosen the machine screws (key 55), reposition the Bourdon tube to get the beam parallel, and retighten the screws.
10. If a Bourdon tube with a different range was installed, remove the machine screw and washer (keys 61 and 60) and dial (key 6). Install a new dial having an adjustment range corresponding to the range of the Bourdon tube. If an optional process pressure gauge (key 4, figure 22) is being used, install a new gauge with the appropriate measurement capability.

Figure 15. Connecting Link

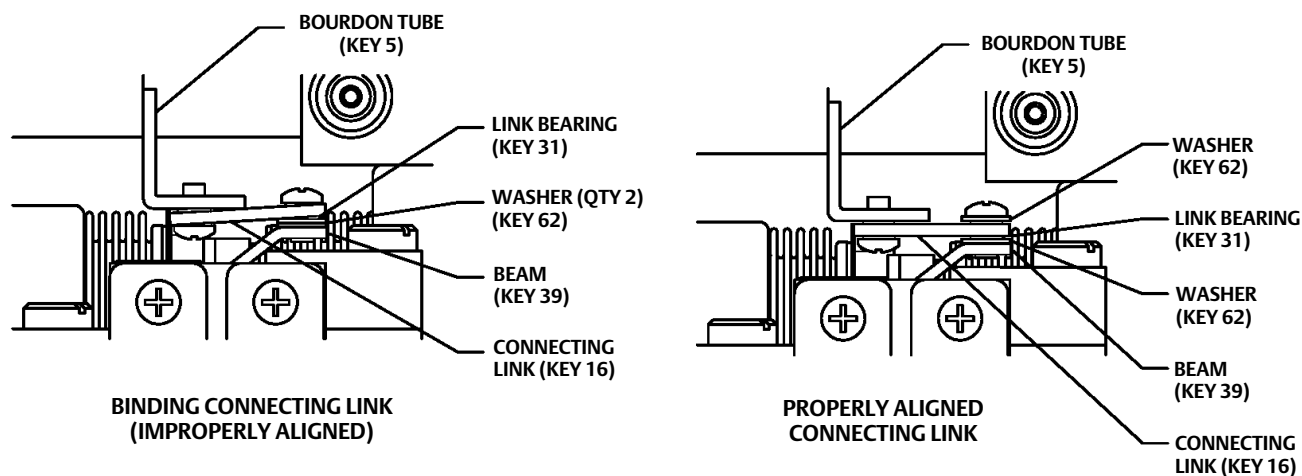

GE37119

11. Check all tubing connections for leaks and the Bourdon tube machine screws, tighten as necessary. Perform the appropriate calibration procedures.

Replacing Bellows Sensing Element

Refer to figure 25 for key number locations unless otherwise directed.

1. Shut off the supply pressure and process lines to the controller or transmitter.
2. Disconnect the tubing from the mounting base (key 57) and calibration adjuster (key 36). Disconnect the tubing that connects the pressure block (key 8, figure 22) to the bellows assembly (key 71), at the pressure block end.
3. Unscrew the four machine screws (key 41, figure 22 or 23), and remove the pressure sensing subassembly from the case.
4. Remove the bellows yoke machine screws and washers (keys 98 and 99), and move the bellows yoke to the right to permit access to the link screw.
5. Disconnect the link (key 71M) and bearing (key 71L) from the beam. Be careful to avoid losing the bearing.
6. Loosen the nuts that secure the bellows assembly (key 71), and remove this assembly from the bellows yoke (key 100).
7. For a gauge-pressure sensing element (only one bellows in the assembly), install the proper bellows spring (key 104) into the bellows assembly if the input signal range is being changed.
8. Install the new bellows assembly into the bellows yoke.
9. Attach the link and bearing to the bellows assembly. Position the bellows yoke (key 100) on the mounting base (key 57), and attach the link and bearing to the beam. Start but do not tighten the four machine screws (key 98) with washers (key 99) that attach the yoke to the mounting base. Slide the yoke up or down as necessary to position the beam horizontally, as shown in figure 25. Tighten the machine screws.
10. Replace the subassembly in the case and secure with the four machine screws (key 41, figure 22 or 23). Reconnect all tubing.
11. If a bellows assembly with a different range is installed, remove the machine screw and washer (keys 61 and 60) and dial (key 6), and install a new dial having an adjustment range corresponding to the range of the bellows. If an optional process pressure gauge (key 4, figure 22) is being used, install a new gauge with the appropriate measurement capability.

12. Check all tubing connections for leaks and the bellows yoke machine screws, tighten as necessary. Perform the appropriate calibration procedures.

Changing Reset Valve

1. Disconnect the appropriate tubing and remove the reset restriction valve assembly (key 256, figure 23) by removing the screw (key 22, not shown) from the back of the case. Install the desired replacement assembly.
2. Connect the tubing, check all connections for leaks and perform the appropriate calibration procedures.

Changing Anti-Reset Windup Differential Relief Valve

Refer to figure 24 for key number locations.

1. Note the controller output pressure (zero or supply) when the process is shut down.
2. Remove the differential relief valve assembly.
3. Refer to figure 14. Install the replacement relief valve with the arrow positioned so that the controller output will be as noted in step 1 when the process is shut down.

Changing Action

Proportional-Only to a Differential Gap Controller

A proportional-only controller may be changed to a differential gap controller, or vice versa, by changing the position of the proportional tubing and inverting the proportional band assembly.

1. Isolate the controller or transmitter from process, control, and supply pressure. Vent any trapped pressure from the controller or transmitter before proceeding with the following steps.
2. Disconnect the proportional tubing (key 25, figure 16) from the mounting base (key 57, figure 24 or 25) and reinstall it in the other connection in the mounting base.

Figure 16. Reverse/Direct Acting Tubing Connection for Differential Gap Controller

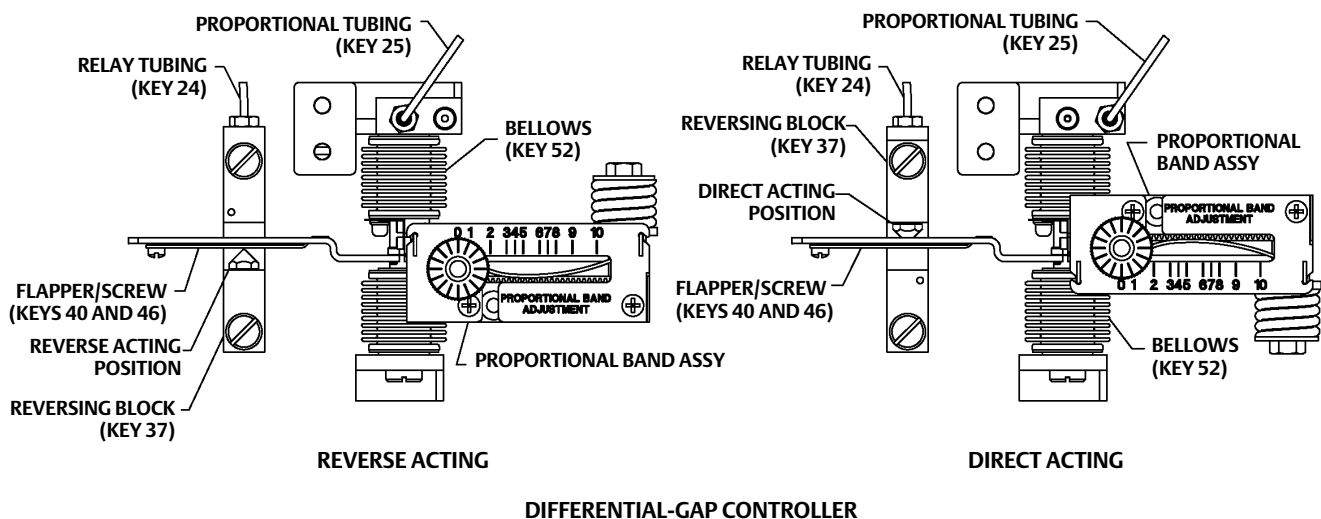

GE34724-B

3. Do not invert the reversing block unless also changing the controller action from direct to reverse (or vice versa).
4. Invert the proportional band assembly (refer to figure 17):
 - a. Turn the proportional band adjustment knob (key 73) to 10.
 - b. Unscrew the spring adjustor (key 65), removing the bias spring (key 70) and washers (key 64) with it.
 - c. Unclip the lock spring (key 72). Remove the indicator scale (key 69) and proportional band adjustment knob (key 73).
 - d. Remove the gain adjustment bar (key 63). Flip it over so it attaches to the opposite side of the cantilever spring (key 8), as shown in figure 16, and screw it back down.
 - e. Flip over the indicator scale (key 69); install it and the proportional band adjustment knob (key 73) as a unit. Snap in the lock spring (key 72).
 - f. Tighten down the spring adjustor (key 65) with the bias spring (key 70) and washers (key 64) until it stops against the gain adjustment bar (key 63).
 - g. Turn the proportional band adjustment knob to the 10 setting. If it cannot be turned to the 10 setting loosen the spring adjustor (key 63).
5. Check all connections for leaks with a soap-and-water solution. Perform the appropriate calibration procedure.

Figure 17. Proportional Band Assembly

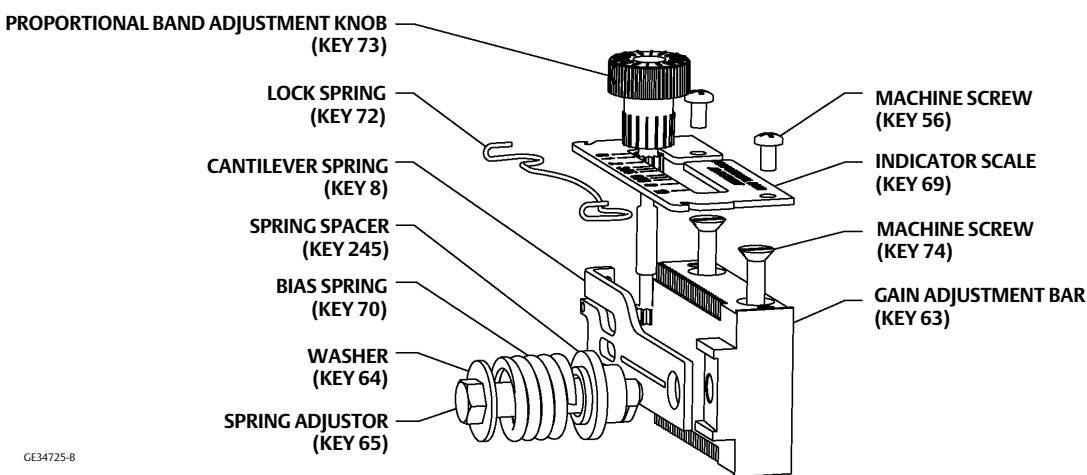

GE34725-B

Reverse to Direct Action

Use the numbered steps below to change from reverse action (increasing process pressure produces decreasing output pressure) to direct action (increasing process pressure produces increasing output pressure), or vice versa. Changing the action is accomplished by reversing the positions of the reversing block, proportional band assembly, and bellows tubing(s). Refer to figures 16, 17, 18, and 21 for key number locations unless otherwise directed.

1. Isolate the controller or transmitter from process, control, and supply pressure. Vent any trapped pressure from the controller or transmitter before proceeding with this procedure.
2. As shown in figure 18, locate the new tubing, proportional band assembly, and reversing block positions for the desired action.

Figure 18. Reverse/Direct Acting Tubing Connections for Proportional Controllers or Transmitter

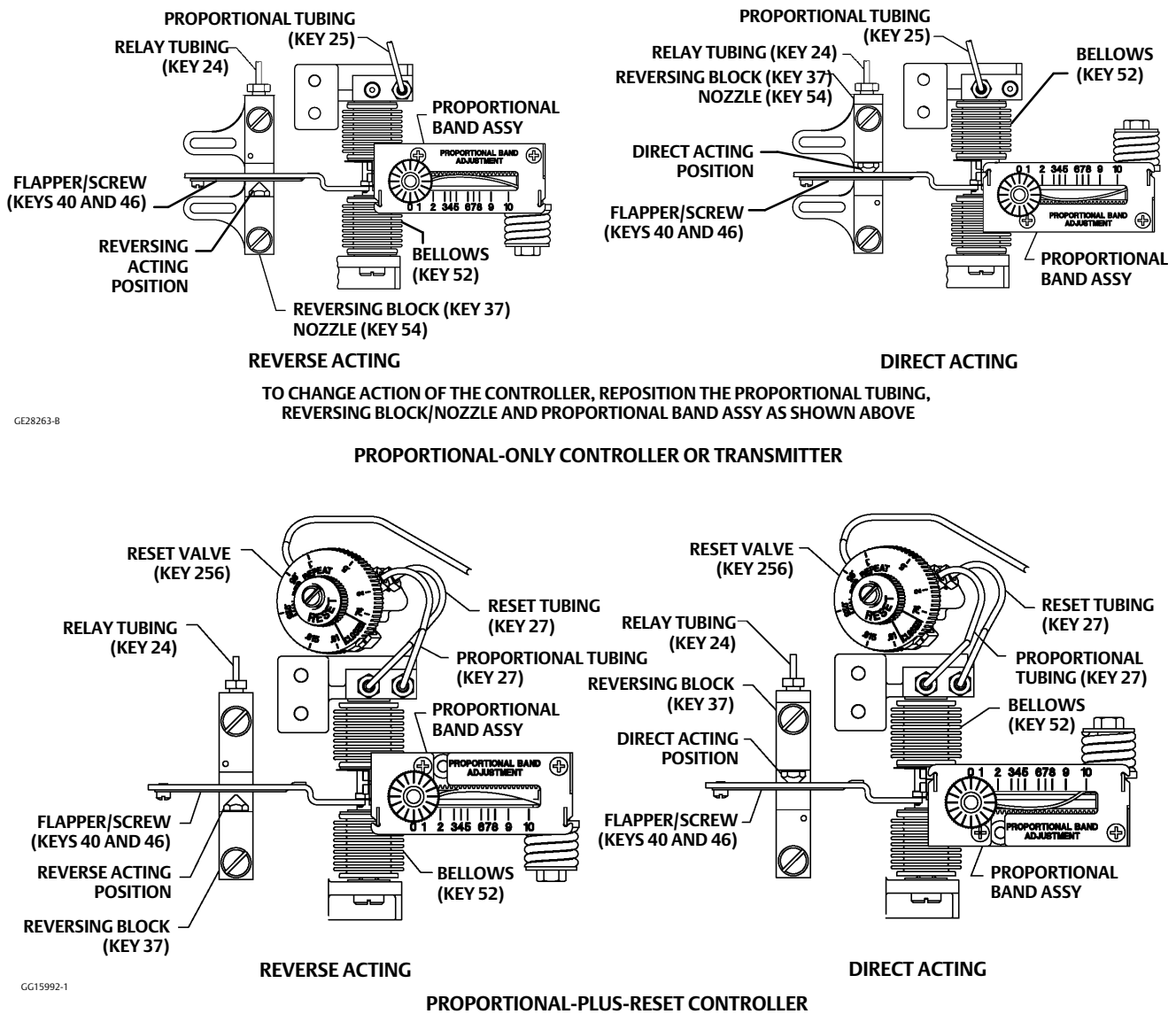

3. Locate the two bellows (key 52), the proportional band assembly (see figure 18), and the reversing block (key 37).
4. Disconnect the tubing (refer to figure 18):
 - a. For a proportional-only controller or for a transmitter, disconnect the proportional tubing (key 25) from the mounting base and reconnect them on the opposite side.
 - b. For a proportional-plus-reset controller, disconnect the proportional tubing (key 27) and reset tubing (key 27) from the mounting base and reconnect them on the opposite side.
5. Invert the proportional band assembly (refer to figure 17):
 - a. Turn the proportional band adjustment knob (key 73) to 10.

- b. Unscrew the spring adjustor (key 65), removing the bias spring (key 70) and washers (key 64) with it.
 - c. Unclip the lock spring (key 72). Remove the indicator scale (key 69) and proportional band adjustment knob (key 73).
 - d. Remove the gain adjustment bar (key 63). Flip it over so it attaches to the opposite side of the cantilever spring (key 8) as shown in figure 18 and re-attach.
 - e. Flip over the indicator scale (key 69, figure 17); install it and the proportional band knob (key 73) as a unit. Snap in the lock spring (key 72).
 - f. Tighten down the spring adjustor (key 65) with the bias spring (key 70) and washers (key 64) until it stops against the gain adjustment bar (key 63).
 - g. Turn the proportional band adjustment knob to the 10 setting. If it cannot be turned, loosen the spring adjustor (key 65).
6. Change the reversing block assembly (figure 16 or 18, key 37):
- a. Remove the sealing screw (key 49, figure 24 or 25). Inspect the O-ring (key 77 located in the recessed area under the sealing screw head. Replace the O-ring if necessary.
 - b. Remove the reversing block screw (key 50, figure 24 or 25) and reversing block assembly (key 37). Inspect the O-rings (key 77) located in the recessed area under the reversing block screw head and between the reversing block assembly and the calibration adjuster (key 36). Replace these O-rings if necessary.
 - c. Position the reversing block assembly, with an O-ring, on the calibration adjuster (key 36) so that the nozzle is on the opposite side of the beam (key 39) from which it was removed. Position the reversing block hole in the calibration adjuster. Install the reversing block screw (key 50) with an O-ring (key 77).
 - d. Install the sealing screw (key 49) with an O-ring in the hole previously covered by the reversing block assembly.
7. Check all connections for leaks with a soap-and-water solution. Perform the appropriate calibration procedures.

Relay Replacement

Key numbers used in this procedure are shown in figure 22 or 23 except where indicated.

1. Shut off the supply pressure and process pressure line(s) to the controller or transmitter.
2. Disconnect the tubing (key 24) from the relay.
3. Unscrew the output or supply pressure gauge (key 2).
4. To remove the relay assembly, unscrew two Phillips-head machine screws (key 29, not shown) located behind the relay on the back of the case.
5. Remove the relay gasket (key 19, figure 22).
6. A new relay can be installed as a replacement. If a new relay is being installed, continue with the next step.
7. Attach the replacement relay and new relay gasket with machine screws inserted through the back of the case. Reinstall the output or supply gauge.
8. Connect the tubing, and check all connections for leaks. Perform the appropriate calibration procedures.

Changing Output Signal Range

Use the following information and subsequent procedures when changing the output signal range of the controller or transmitter. Use the following procedure:

- For a controller or transmitter, use this procedure to change from a 0.2 to 1.0 bar (3 to 15 psig) to a 0.4 to 2.0 bar (6 to 30 psig) output signal range or vice versa (also see figure 19).
- For a differential gap controller, use this procedure to change from a 0 and 1.4 bar (0 and 20 psig) to a 0 and 2.4 bar (0 and 35 psig) output signal range or vice versa (also see figure 19).
- When changing the supply pressure source to a new range, refer to table 5 for supply pressure requirements for the output signal range selected.

Figure 19. Changing From a 0.2 to 1.0 bar (3 to 15 psig) to a 0.4 to 2.0 bar (6 to 30 psig) Output Signal Range or Vice Versa

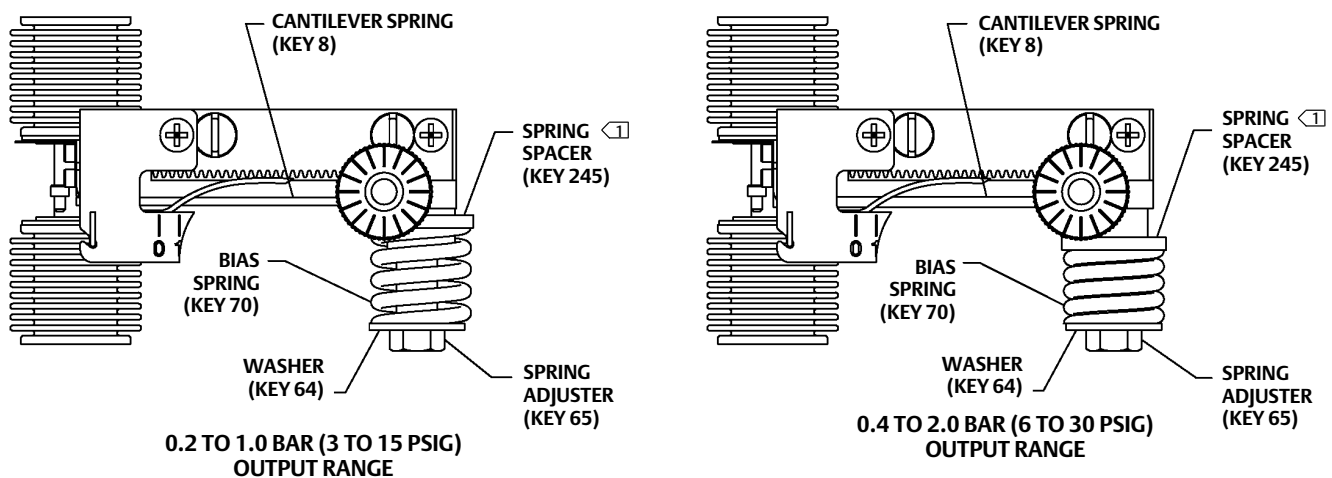

NOTE
 [1] REVERSE THE SPRING SPACER AS APPROPRIATE TO CHANGE THE BIAS SPRING WORKING LENGTH.

GG15991-A

Also, make appropriate changes to the nameplate of the controller or transmitter, reflecting the new range selections. Refer to figure 24 or 25 for key number locations unless otherwise directed.

1. Shut off the supply pressure and process lines to the controller or transmitter.
2. Disconnect the tubing from the mounting base (key 57) and calibration adjuster (key 36).

Disconnect the tubing that connects the pressure block (key 10, figure 22 or 23) to the Bourdon tube or bellows assembly (key 5 or 52), at the pressure block end.

3. Unscrew the machine screws (key 41, figure 22 or 23), and remove the subassembly from the case.
4. If the controller or transmitter uses a Bourdon tube sensing element disconnect the Bourdon tube from the beam (key 39) by removing the screw (key 56). Be careful to avoid losing the bearing (key 31). Unscrew the machine screws (key 55) and remove the washers and Bourdon tube (keys 45 and 5).

5. Unscrew the bellows screws (key 53) from each end of the mounting base (key 57).

Note

The bellows screws (key 53) have an O-ring (key 77, figure 20) installed beneath the bellows screw head. Remove the O-ring and obtain a replacement when re-assembling the bellows.

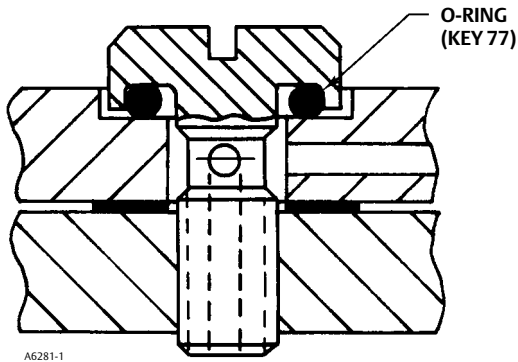
Figure 20. Bellows Screw Detail

6. Unscrew the spring adjustor (key 65). Unclip the lock spring (key 72, figure 17) and remove the indicator scale (key 69) and the proportional band adjustment knob (key 73).
7. Compress the bellows (key 52) so that the end of the bellows, beam (key 39), and cantilever spring (key 8) can be removed from the mounting base (key 57).
8. Unscrew the bellows (key 52) from the bellows/cantilever assembly.
9. Remove the cantilever spring from the spacer (key 34).
 - a. Remove the beam machine screws (figure 21, step ↘).
 - b. Remove the cantilever machine screws (figure 21, step ↙).
 - c. Remove the inner flexure (figure 21, step ↖) and install it on the new cantilever.
10. Install the new cantilever spring (key 8) and reconnect the beam (key 39) to the bellows spacer (key 34) in reverse sequence of steps 9a and 9b and reattach the bellows to the beam/cantilever assembly.
11. Compress the bellows and install them into the mounting base (key 57). Align the cantilever spring with the gain adjustment bar (key 63). For 0.2 to 1.0 bar (3 to 15 psig) and 0.4 to 2.0 bar (6 to 30 psig) output ranges: reverse the spring spacer (key 245) as shown in figure 19. Install the indicator scale (key 69) and the proportional band adjustment knob (key 73) as a unit. Snap the lock spring (key 72) onto the indicator scale.
12. Install the spring adjustor (key 65, figure 17) and washer (key 64, figure 17) on the bias spring (key 70, figure 17). Tighten down the spring adjustor until it stops against the gain adjustment bar (key 63).

13. Turn the proportional band adjustment knob to 10. If it cannot be turned to 10 loosen the spring adjustor (key 65).
14. Secure the bellows (key 52) with the bellows screws (key 53), making sure that the nozzle (key 54) is centered on the flapper (key 40).
15. Unscrew the supply and output gauges (figure 22 or 23, key 2) and install new gauges with correct ranges.
16. Replace the subassembly in the case and secure with machine screws (figure 22 or 23, key 41). Re-install the Bourdon tube if it was removed; refer to the Replacing the Bourdon Tube section. Reconnect all tubing.
17. Check all tubing connections and the bellows machine screws for leaks; tighten as necessary. Perform the appropriate calibration procedures.

Figure 21. Beam/Cantilever Spring Assembly

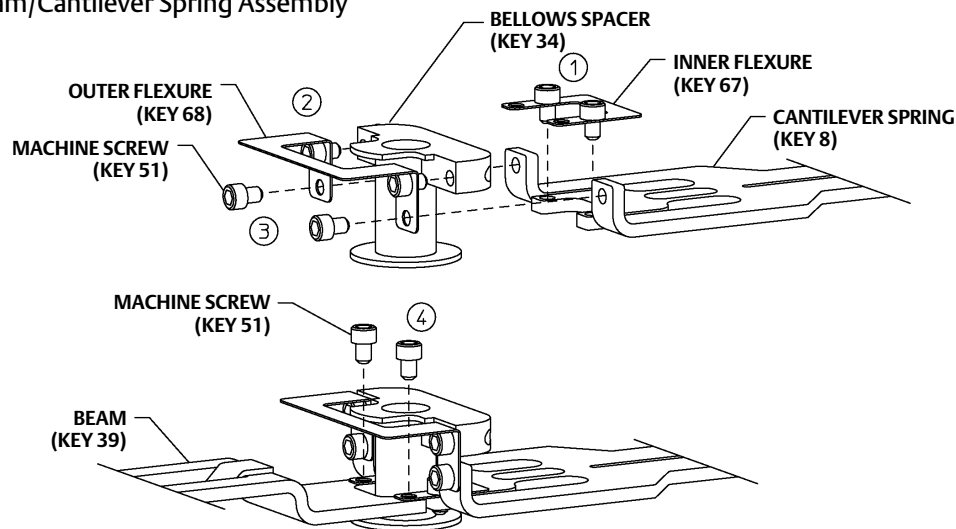

GE34726-B
E1068

Parts Ordering

Whenever corresponding with your [Emerson sales office](#) about this equipment, mention the serial number of the unit. The serial number can be found on the nameplate (key 22, figure 22).

⚠ WARNING

Use only genuine Fisher replacement parts. Components that are not supplied by Emerson Automation Solutions should not, under any circumstances, be used in any Fisher instrument. Use of components not supplied by Emerson may void your warranty, might adversely affect the performance of the instrument, and could cause personal injury or property damage.

Parts Kits

Description	Part Number
Controller Repair Kits Kit includes Gasket, Relay Gasket, Bellows Frame Gasket, and keys 16, 20, 21, 31, 37, 38, 40, 46, 49, 50, 54, 62, 75, 76, and 77	

Note

Keys 71K, 71L, and 71M may also be necessary for repair of C1B and C1D controllers. Refer to the Common Parts section for part numbers.

Standard Temperature	RC100X00L12
High Temperature	RC100X00H12
Relay Replacement Kits Kit includes keys 19 and 29, the replacement relay, and 2 Machine Screws	
Standard Temperature	RRELAYX0L22
High Temperature	RRELAYX0H22
Case Assembly Seal Kit Kit includes 3 Manifold Seals, 1 Manifold Cover, and 10 Mounting Screws	RC100X00012
C1P Tubing Replacement Kit Kit includes key 23, 24, 25, 26, and 27	RC100XTRK12

Parts List

Note

Contact your [Emerson sales office](#) for Part Ordering information.

Common Parts (Figures 22, 23, 24, and 25)

Key Description

1 Case and Cover Assembly

Key Description

Note

Key 2 is used as both a supply gauge and an output gauge on units without a process pressure gauge. A quantity of 2 is required for these units. On units with a process pressure gauge (key 106), key 2 is used for the output gauge. A quantity of 1 is required for these units. Use key 3 for supply pressure indication when a process pressure gauge is installed. Key 3 installs on the supply pressure regulator.

- 2* Supply and Output Pressure Gauge, w/o process pressure gauge (1/8-inch connecting stem), (2 req'd)
 - Dual scale
 - 0-2.0 kg/cm² and 0-30 psig
 - 0-4.0 kg/cm² and 0-60 psig
 - Triple scale
 - 0-2.0 bar, 0-0.2 MPa, and 0-30 psig
 - 0-4.0 bar, 0-0.4 MPa, and 0-60 psig
 - 0-2.0 kg/cm² and 0-30 psig
 - 0-4.0 kg/cm² and 0-60 psig
- 2* Output Pressure Gauge, w/process pressure gauge (1/8-inch connecting stem)
 - Triple scale
 - 0-2.0 bar, 0-0.2 MPa, and 0-30 psig
 - 0-4.0 bar, 0-0.4 MPa, and 0-60 psig
- 3* Supply Pressure Gauge, w/process pressure gauge (1/4-inch connecting stem)
 - Triple scale
 - 0-2.0 bar, 0-0.2 MPa, and 0-30 psig
 - 0-4.0 bar, 0-0.4 MPa, and 0-60 psig

Note

Controllers with bellows sensing element use only the 2.0 bar, 0 to 0.2 MPa, and 0 to 0 to 30 psig triple scale brass and stainless steel process pressure gauges. Differential pressure controllers do not use a process pressure gauge.

- 4* Process Pressure Indicator Gauge (use only when specified)
 - Triple scale
 - 0-2.0 bar, 0-0.2 MPa, and 0-30 psig
 - 0-20 bar, 0-2.0 MPa, and 0-300 psig
 - 0-69 bar, 0-6.9 MPa, and 0-1000 psig

*Recommended spare parts

Figure 22. Typical Reverse Acting Fisher C1 Assembly
(Refer to figure 26 for the Front View of the Case & Cover Assembly)

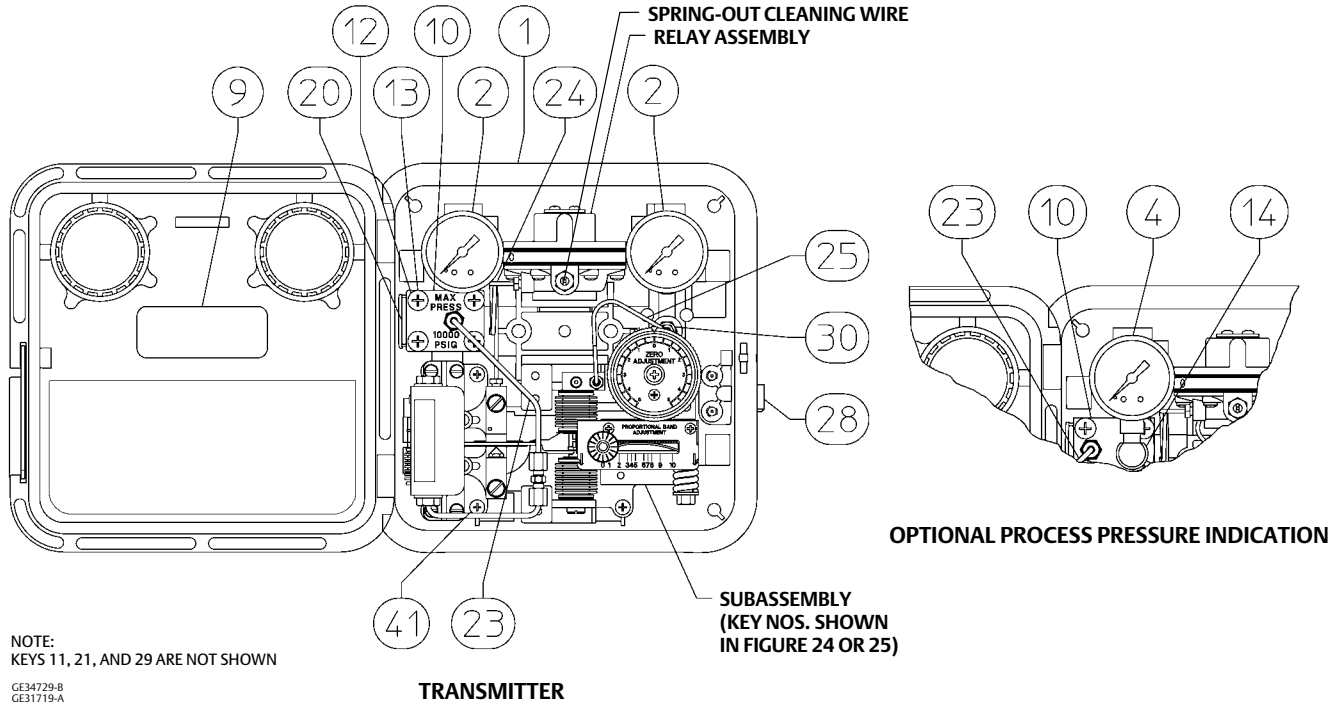

Key	Description	Key	Description
5*	Bourdon Tube	11	Plug (not shown) used with gauge pressure only 1 req'd for standard/NACE 2 req'd for oxygen service
6	Dial	12	Machine Screw (4 req'd)
7	Screw (transmitters only)	13	Lockwasher (4 req'd)
8*	Cantilever Spring 3-15 psi range 6-30 psi range	14	Pressure Connection Use w/process gauge
9	Nameplate	15	Pipe Plug (not shown) Use w/process gauge, not used w/Bourdon tube protector
10	Control Pressure Block For gauge pressure instruments w/o process pressure gauge for standard, NACE and oxygen service w/process gauge		

Figure 22. Typical Reverse Acting Fisher C1 Assembly (continued)
 (Refer to figure 26 for the Front View of the Case & Cover Assembly)

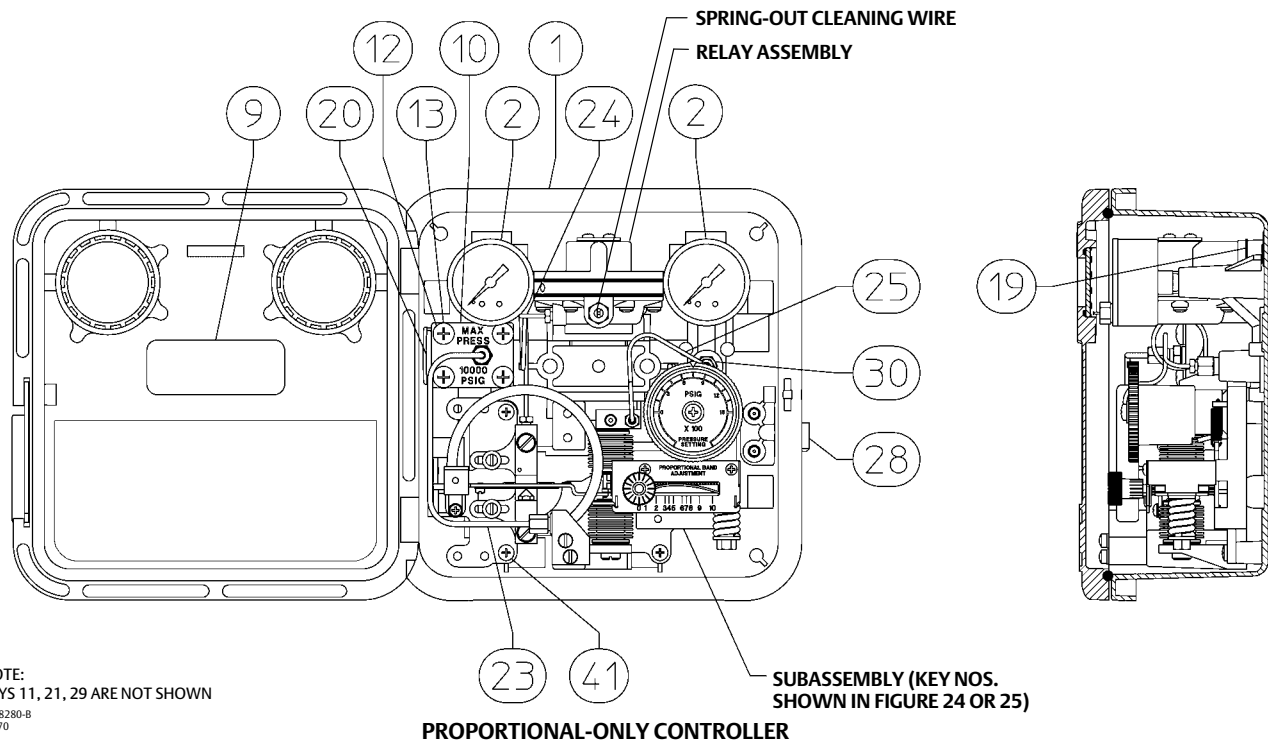

Key Description

- 16* Connecting Link⁽¹⁾, Bourdon tube instruments only
- 16 Connecting Link, Bourdon tube w/optional travel stop
- 17 Lockwasher (2 req'd)
Use w/optional Bourdon tube travel stop
- 18 Machine Screw (2 req'd)
Use w/optional Bourdon tube travel stop
- 19* Relay Gasket⁽¹⁾
Std Temp
Hi Temp

Key Description

- 20* O-Ring⁽¹⁾
- 21* Gasket⁽¹⁾ (not shown)
- 22 Mounting Screw for reset restriction valve
1/4-20 UNC (not shown)
- 23* Control Tubing Assembly
For Bourdon tube instruments
w/o process pressure gauge
Std.
Oxygen Service
w/process pressure gauge

*Recommended spare parts

1. This part is included in the Controller Repair Kit.

Figure 23. Typical Reverse Acting Fisher C1 Proportional-Plus-Reset Assembly
(Refer to figure 26 for the Front View of the Case & Cover Assembly)

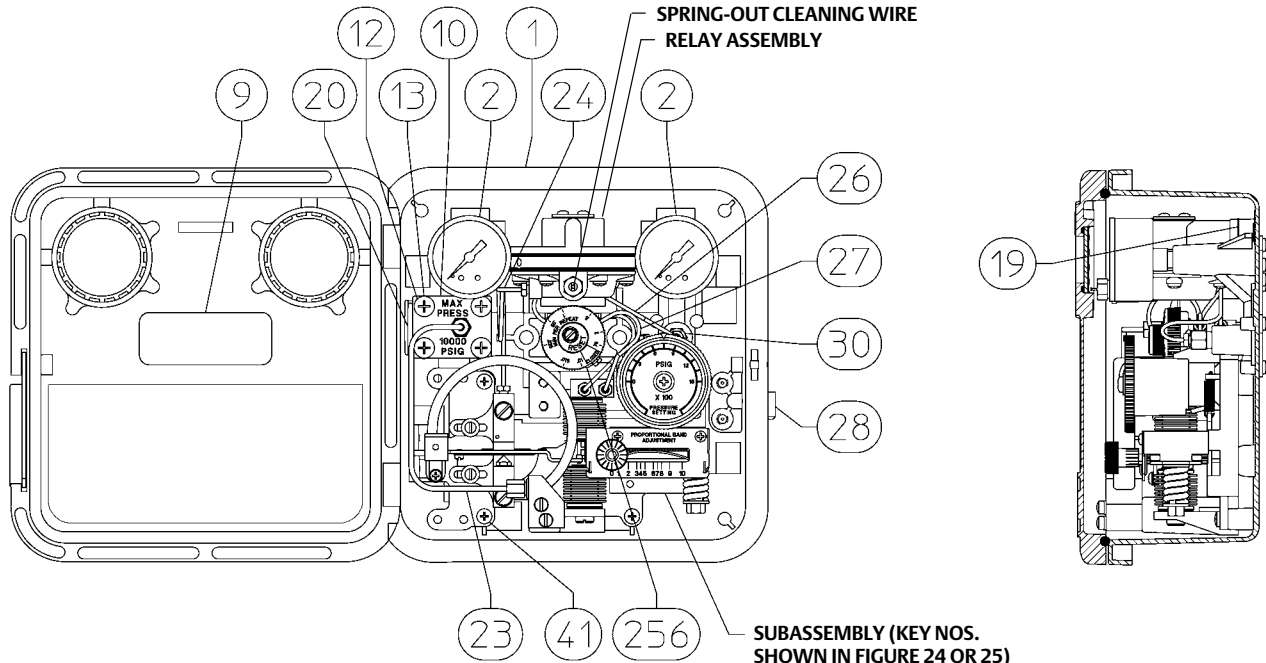

NOTE:
KEYS 11, 21, 22, 29 ARE NOT SHOWN

GE28281-B
E1071

**PROPORTIONAL-PLUS-RESET CONTROLLER
WITHOUT ANTI-RESET WINDUP**

Key	Description	Key	Description
23*	Control Tubing Assembly	39	Beam
24*	Relay Tubing Assembly	40	Flapper ⁽¹⁾
25*	Compensator Tubing	41	Machine Screw (4 req'd)
26*	Reset Tubing	42	Flexure Strip
27*	Compensator Tubing (2 req'd)	43	Flexure Strip Washer (2 req'd)
28	Vent Ass'y	44	Washer (2 req'd)
29	Machine Screw ⁽²⁾ , (not shown) (2 req'd)	45	Washer (2 req'd)
30	NPT Adaptor	46	Machine Screw ⁽¹⁾
31*	Link bearing ⁽¹⁾ Bourdon tube instruments only (2 req'd)	47	Machine Screw (4 req'd)
32	Rotary Spring	48	Machine Screw (2 req'd)
33	Bellows Stud (not shown)	49	Sealing Screw ⁽¹⁾
34	Spacer	50	Reversing Block Screw ⁽¹⁾
35	Pressure Set Arm	51	Cap Screw (8 req'd)
36	Calibration Adjuster	52*	Reversing Bellows Ass'y (2 req'd)
37	Reversing Block ⁽¹⁾	53	Bellows Screw (2 req'd)
38	Sleeve ⁽¹⁾	54*	Nozzle ⁽¹⁾
		55	Machine Screw (2 req'd)
		56	Machine Screw (4 req'd)
		57	Mounting Base

*Recommended spare parts

1. This part is included in the Controller Repair Kit.
2. This part is included in the Relay Replacement Kit.

Figure 23. Typical Reverse Acting Fisher C1 Proportional-Plus-Reset Assembly (continued)
(Refer to figure 26 for the Front View of the Case & Cover Assembly)

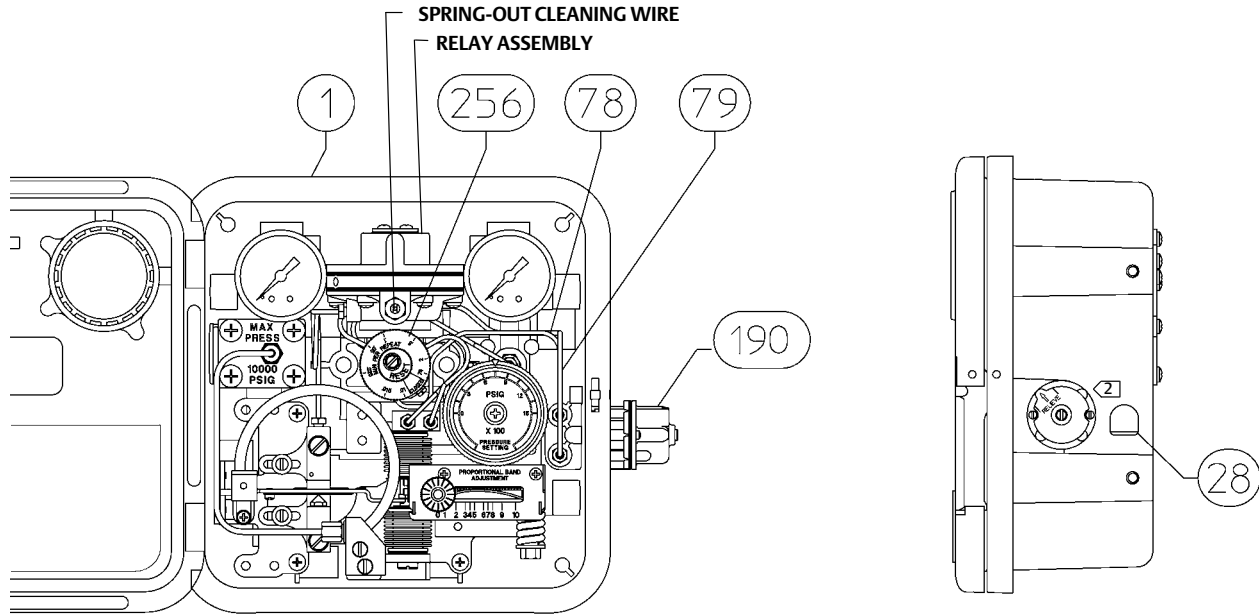

NOTES:

- 1 ARROW DOWN—RELIEVES ON DECREASING OUTPUT (OUTPUT @ SUPPLY DURING SHUTDOWN)
 - 2 ARROW UP—RELIEVES ON INCREASING OUTPUT (OUTPUT @ ZERO DURING SHUTDOWN)
- KEYS 80, 81, AND 82 ARE NOT SHOWN

GE31718-A
E1072

**PROPORTIONAL-PLUS-RESET CONTROLLER WITH
DIFFERENTIAL RELIEF VALVE ASSEMBLY FOR ANTI-RESET WINDUP**

Key	Description	Key	Description
58	Knob	71*	Gauge Pressure Bellows (input) ⁽³⁾ 0-150 mbar (0-60 inches wc) positive, 0-150 mbar (6-60 inches wc) vacuum, and 75-0-75 mbar (30-0-30 inches wc) compound 0-250 mbar (0-100 inches wc) positive 0-0.35 mbar (0-5 psig) positive and for 0-350 mbar (0-10 inches Hg) vacuum 0-0.5 bar (0-7.5 psig) positive 0-0.7 bar (0-10 psig) positive 0-1.0 bar (0-15 psig) positive, 0-1.0 bar (0-30 inches Hg) vacuum, and 500-0-500 mbar (15-0-7.5 psig) compound 0-1.4 bar (0-20 psig) positive 0-2.0 bar (0-30 psig) positive and 1.0-0-1.0 bar (30-0-15 psig) compound
59	Knob Spring		
60	Washer		
61	Machine Screw		
62	Washer ⁽¹⁾ (2 req'd)		
63	Gain Adj Bar		
64	Washer		
65	Spring Adjustor		
66	Travel Stop Assembly Use w/optional Bourdon tube travel stop		
67*	Inner Flexure		
68*	Outer Flexure		
69	Indicator Scale		
70	Bias Spring		

*Recommended spare parts

- 1. This part is included in the Controller Repair Kit.
- 3. If ordering the bellows (key 71) to change the range of a gauge pressure controller, also order the appropriate bellows spring (key 80). Also order keys 101, 102, and 103 if you do not have them.

Figure 24. Controller Subassembly with Bourdon Tube Sensing Element

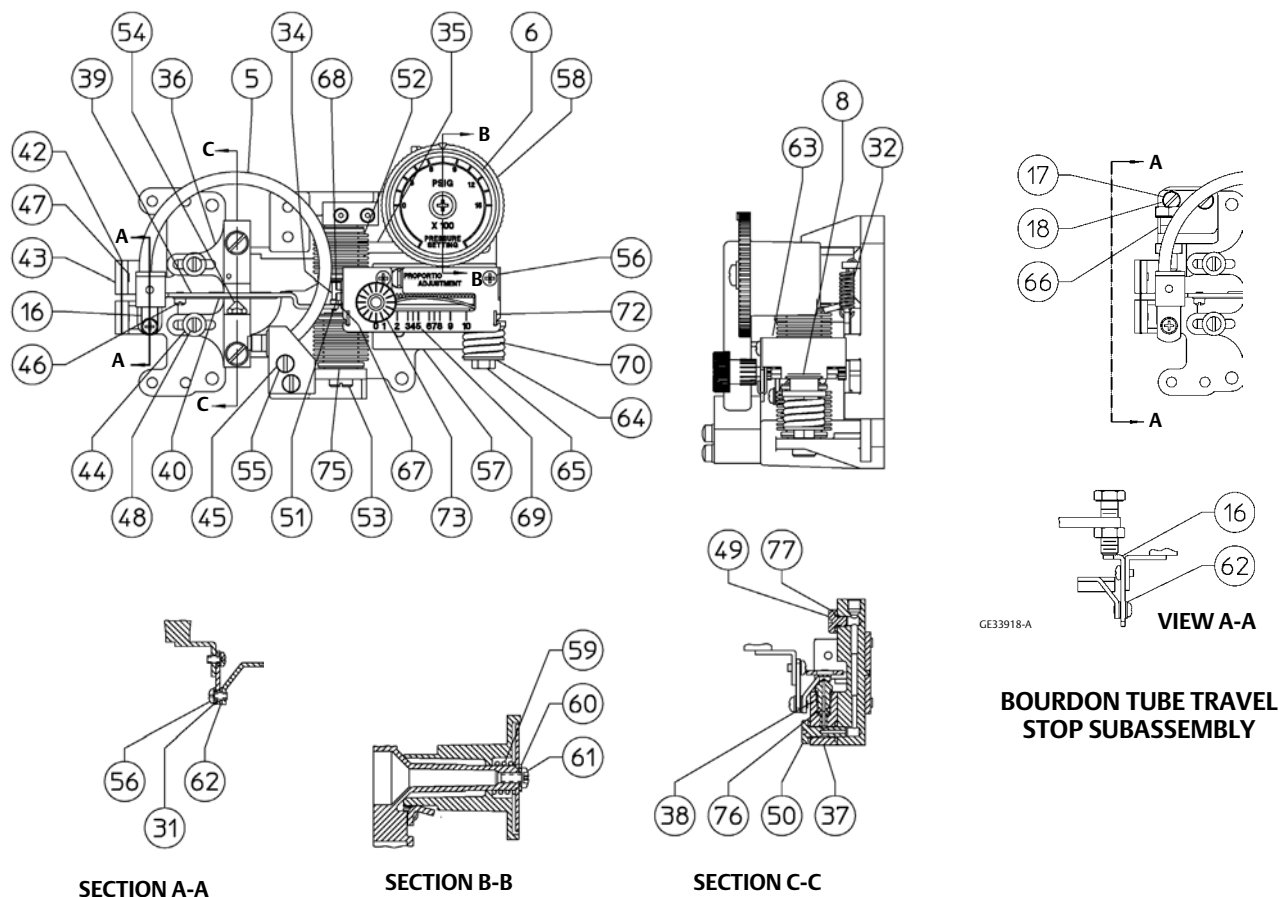

NOTE:
KEYS 33 AND 74 ARE NOT SHOWN
GE26600-C

Key	Description
71*	Differential-Pressure Bellows (input) 0-200 mbar (0-80 inches wc) 0-0.7 bar (0-10 psi) 0-1.4 bar (0-20 psi) 0-2.0 bar (0-30 psi)
71K	Machine Screw ⁽⁴⁾ bellows sensing instruments only (2 req'd)
71L*	Bearing ⁽⁴⁾ bellows sensing instruments only (2 req'd)
71M*	Link ⁽⁴⁾ bellows sensing instruments only

Key	Description
72*	Lock Spring
73	Proportional Band Adjustment Knob
74	Machine Screw ⁽¹⁾ (2 req'd)
75*	Gasket ⁽¹⁾ Std Temp (2 req'd) High Temp (2 req'd)
76*	Nozzle O-Ring ⁽¹⁾ , Std Temp High Temp

*Recommended spare parts

1. This part is included in the Controller Repair Kit.
keys 101, 102, and 103 if you do not have them.
4. This part is part of the bellows assembly, key 71.

Figure 25. Controller Subassembly with Either Gauge-Pressure Bellows or Differential-Pressure Bellows Sensing Element

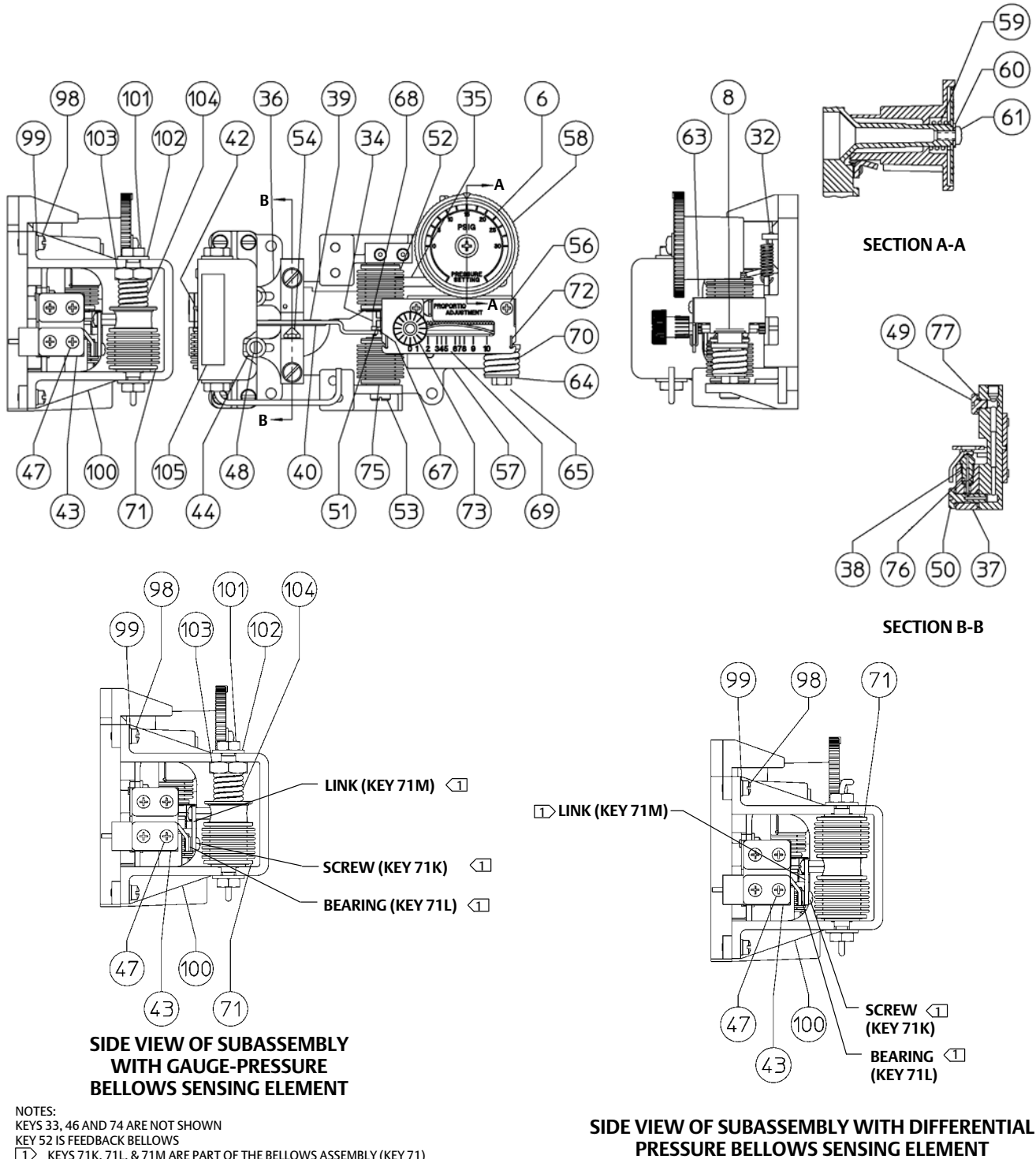

SIDE VIEW OF SUBASSEMBLY WITH GAUGE-PRESSURE BELLOWS SENSING ELEMENT

SIDE VIEW OF SUBASSEMBLY WITH DIFFERENTIAL PRESSURE BELLOWS SENSING ELEMENT

NOTES:
 KEYS 33, 46 AND 74 ARE NOT SHOWN
 KEY 52 IS FEEDBACK BELLOWS
 □ KEYS 71K, 71L, & 71M ARE PART OF THE BELLOWS ASSEMBLY (KEY 71)
 GE35161-A
 GE34735-C

Key Description

Note

A total of 5 O-rings (key 77) are used. 1 O-ring is used under the sealing screw (key 49), 1 O-ring is used under the reversing block screw (key 50), 1 O-ring is used between the reversing block ass'y (key 52) and the calibration adjuster (key 36), and 1 O-ring is used in the recessed area under the head of each of the bellows screws (key 53).

- 77* O-Ring (5 req'd)
Std Temp
High Temp

Note

Keys 78 through 82 are used for Proportional-Plus-Reset controllers only.

- 78 Tubing Assembly
- 79 Tubing Assembly
- 80 Anti-Reset Windup Cover (not shown)
- 81* O-Ring (not shown) (2 req'd)
- 82 Machine screw (not shown) (2 req'd)

Key Description

- 98 Machine Screw (4 req'd)
Gauge and differential pressure bellow instruments
- 99 Washer
for Bourdon tube instruments (2 req'd)
for bellows sensing instruments (4 req'd)
- 100 Bellows Yoke
use with gauge and differential pressure bellows

Note

Keys 101 through 105 are used for gauge pressure bellows instruments only.

- 101 Jam Nut
- 102 Washer
- 103 Spring seat
- 104 Spring
- 105 Label, bellows sensing instruments only
- 190 Anti-Reset Windup Ass'y
For Proportional-Plus-Reset Controllers only
- 245 Spring Spacer
- 256 Reset Restriction Valve
For proportional-plus-reset controllers
w/o anti-reset windup
For proportional-plus-reset controllers
w/ anti-reset windup

Figure 26. Front View of Case and Cover Assembly

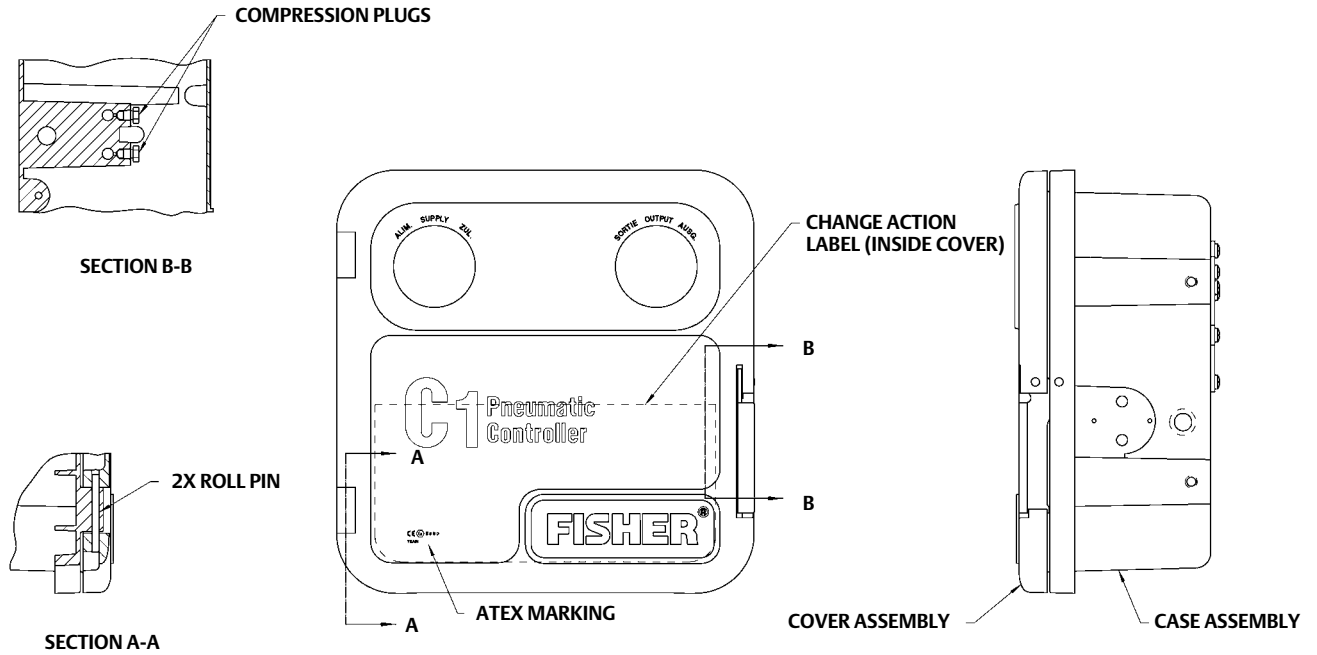

CE28278-B
E1075-1

Mounting Parts for Panel, Wall, Pipestand, or Fisher Actuator Mounting (figures 2 and 3)

Key	Description
213	<p>Mounting Plate</p> <p>For yoke mounting on 470, 472, 513, 656, 657 and 667</p> <p>For yoke mounting on 480 Vertical</p> <p>For yoke mounting on 1051 and 1052</p> <p>Size 40, positions 1 and 3 w/switch and</p> <p>Size 60, position 1 w/switch</p> <p>All others</p> <p>For yoke mounting on 1061 Size 30, positions 1 and 3 w/switch and position 1 w/o switch, Size 40, position 1 w/switch and</p> <p>Sizes 80 and 100, position 3 w/o switch</p> <p>All others</p> <p>For pipe stand mounting</p>
215	<p>Machine Screw (specify quantity req'd)</p> <p>5/16 UNC X 1 inch</p> <p>5/16 UNC X 1-1/2 inches</p> <p>5/16 UNC X 2 inches</p>
216	<p>Hex Nut (specify quantity req'd)</p> <p>For filter regulator mounting on 1051, 1052 and 1061</p> <p>All other types and mountings</p>
220	<p>Mounting Bracket (not shown)</p> <p>For casing mounting and casing-mounted filter regulator on 1051 and 1052</p>
221	<p>Lockwasher (specify quantity req'd)</p>
222	<p>Cap Screw (specify quantity req'd)</p> <p>5/16 UNC X 3/4 inch</p> <p>5/16 UNC X 1 inch</p> <p>5/16 UNC X 1-1/8 inches</p> <p>5/16 UNC X 1-1/4 inches</p> <p>5/16 UNC X 1-3/4 inches</p> <p>5/16 UNC X 2-1/2 inches</p> <p>3/8 UNF X 1-1/8 inches</p>
223	<p>Cap Screw</p> <p>1051 and 1052 with either case or yoke mounted regulator and 1061 with yoke mounted regulator (2 req'd)</p>
228	<p>Spacer Spool (specify quantity req'd)</p> <p>470, 472, 480, 513, 656, 657, 667, pipe stand 1051, 1052 and 1061</p>
229	<p>Cap Screw (not shown) (specify quantity req'd)</p> <p>1051 and 1052 casing-mounted controller</p>
238	<p>Mounting Plate</p> <p>For yoke-mounted filter regulator</p> <p>1051, 1052 and 1062 sizes 40 and 60</p> <p>1061 size 30</p>
240	<p>Cap Screw</p> <p>For yoke-mounted filter regulator on 1051 and 1052 sizes 40 and 60 (2 req'd)</p>
241	<p>Spacer Spool</p> <p>For yoke mounted filter regulators on 1051 and 1052 sizes 40 and 60 (2 req'd)</p>
242	<p>Spacer Spool (not shown)</p> <p>For yoke mounting on 1051 and 1052 size 40 (2 req'd)</p> <p>1061 sizes 30, 80 and 100 (2 req'd)</p>
243	<p>Street Elbow (not shown)</p> <p>For mounting on 470, 472, 480, 513, 656, 657, 667, panel, pipe stand, 1051, 1052 and 1061 w/nipple-mounted filter regulator</p>
244	<p>Pipe Nipple (not shown)</p> <p>For mounting on 470, 472, 480, 513, 656, 657, panel, pipe stand, 1051, 1052 and 1061 w/nipple-mounted filter regulator</p>
250	<p>Clamp</p> <p>For pipe stand mounting (2 req'd)</p>
251	<p>Bracket Assembly</p> <p>For panel or wall mounting (2 req'd)</p>
252	<p>Cap Screw</p> <p>For panel or wall mounting (4 req'd)</p>

Note

Specify quantity of fittings.

Connector

1/4 NPT X 1/4 O.D. tubing
1/4 NPT X 3/8 O.D. tubing

Elbow

1/4 NPT X 1/4 O.D. tubing
1/4 NPT X 3/8 O.D. Tubing

Neither Emerson, Emerson Automation Solutions, nor any of their affiliated entities assumes responsibility for the selection, use or maintenance of any product. Responsibility for proper selection, use, and maintenance of any product remains solely with the purchaser and end user.

Fisher is a mark owned by one of the companies in the Emerson Automation Solutions business unit of Emerson Electric Co. Emerson Automation Solutions, Emerson, and the Emerson logo are trademarks and service marks of Emerson Electric Co. All other marks are the property of their respective owners.

The contents of this publication are presented for informational purposes only, and while every effort has been made to ensure their accuracy, they are not to be construed as warranties or guarantees, express or implied, regarding the products or services described herein or their use or applicability. All sales are governed by our terms and conditions, which are available upon request. We reserve the right to modify or improve the designs or specifications of such products at any time without notice.

Emerson Automation Solutions
Marshalltown, Iowa 50158 USA
Sorocaba, 18087 Brazil
Cernay, 68700 France
Dubai, United Arab Emirates
Singapore 128461 Singapore

www.Fisher.com

